

BYTE

JUNE 1989

A McGRAW-HILL PUBLICATION

REVIEWS

- Mac SE/30
- 6 Hi-Res Hand-Held Scanners
- 6 16-bit VGA Cards
- Tandon and FiveStar 80386s
- CASE:W
- Claris CAD

PRODUCT FOCUS



The Fastest 386s Ever?

*ALR's New 33-MHz,
MCA, and SX Machines*

Special
International-Only
Editorial Section

The 80486 and 68040
Compared

IN DEPTH

Security

PLUS

Zenith's 33-MHz
80386
Inside PC DOS 4.0
Dell 325



LASER PRINTERS.

Laser System 150, 15 pages per minute: \$5,995.
 Laser System 80, 8 pages per minute: \$3,295.
 Laser System 60, 6 pages per minute: \$2,195.

All Dell laser printers come with 1.5 MB RAM, full-page 300 DPI graphics, and have 31 standard fonts (7 resident and 24 downloadable from diskette). Dell laser printers also provide Hewlett-Packard LaserJet Plus[®]; Epson/FX[®]; IBM Proprinter[®] and Diablo 630[®] emulations.



THE DELL SYSTEM 325
25 MHz 386.

When you need the highest-performance 386 computer, this is it.

STANDARD FEATURES:

- Intel 80386 microprocessor running at 25 MHz.
- Choice of 1 MB or 4 MB of RAM* expandable to 16 MB using a dedicated high speed 32-bit memory slot.
- Advanced Intel 82385 Cache Memory Controller with 32 KB of high speed static RAM cache.
- Page mode interleaved memory architecture.
- VGA systems include a high performance 16-bit video adapter.
- Socket for 25 MHz Intel 80387 or 25 MHz WEITEK 3167 math coprocessor.
- 5.25" 1.2 MB or 3.5" 1.44 MB diskette drive.
- Dual diskette and hard disk drive controller.
- Enhanced 101-key keyboard.
- 1 parallel and 2 serial ports.
- 200-watt power supply.
- 8 industry standard expansion slots.

OPTIONS:

- 25 MHz Intel 80387 math coprocessor.
- 25 MHz WEITEK 3167 math coprocessor.
- 1 MB or 4 MB RAM upgrade kit.
- 2 MB or 8 MB memory expansion board kit.

**Lease for as low as \$199/Month. Extended Service Plan pricing starts at \$370.

System 325	With Monitor & Adapter			
	VGA Mono		VGA Color Plus	
Hard Disk Drive	1 MB RAM	2 MB RAM	1 MB RAM	2 MB RAM
40 MB 29ms IDE	\$5,499	\$5,698	\$5,799	\$5,998
90 MB 18 ms ESDI	\$5,999	\$6,198	\$6,299	\$6,498
150 MB 18 ms ESDI	\$6,499	\$6,698	\$6,799	\$6,998
322 MB 18 ms ESDI	\$7,299	\$7,498	\$7,599	\$7,798



THE DELL SYSTEM 220
20 MHz 286.

It's fast as most 386 computers. But at less than half the price. The footprint is small, too.

STANDARD FEATURES:

- 80286 microprocessor running at 20 MHz.
- 1 MB of RAM* expandable to 16 MB (8 MB on system board).
- Page mode interleaved memory architecture.
- LIM 4.0 support for memory over 1 MB.
- Integrated diskette and VGA video controller on system board.
- Socket for Intel 80287 math coprocessor.
- One 3.5" 1.44 MB diskette drive.
- Integrated high performance hard disk interface on system board.
- Enhanced 101-key keyboard.
- 1 parallel and 2 serial ports (integrated on system board).
- 3 full-sized industry standard expansion slots available.

OPTIONS:

- External 5.25" 1.2 MB diskette drive.
 - 3.5" 1.44 MB diskette drive.
 - Intel 80287 math coprocessor.
 - 1 MB or 4 MB RAM upgrade kit.
- **Lease for as low as \$109/Month. Extended Service Plan pricing starts at \$264.

System 220	With Monitor			
	VGA Mono		VGA Color Plus	
Hard Disk Drives	1 MB RAM	2 MB RAM	1 MB RAM	2 MB RAM
40 MB 29ms IDE	\$2,999	\$3,198	\$3,299	\$3,498
100 MB 25ms IDE	\$3,599	\$3,798	\$3,899	\$4,098



THE DELL SYSTEM 200
12.5 MHz 286.

This full-featured 286 computer runs at 12.5 MHz, and is completely Microsoft MS-DOS and MS OS/2 compatible.

STANDARD FEATURES:

- 80286 microprocessor running at 12.5 MHz.
- 640 KB of RAM expandable to 16 MB (4.6 MB on system board).
- Socket for Intel 80287 math coprocessor.
- 5.25" 1.2 MB or 3.5" 1.44 MB diskette drive.
- Dual diskette and hard disk drive controller.
- Enhanced 101-key keyboard.
- 1 parallel and 2 serial ports.
- 200-watt power supply.
- 6 industry standard expansion slots.

OPTIONS:

- Intel 80287 math coprocessor.
- 512 KB RAM upgrade kit.
- 2 MB RAM upgrade kit.

Extended Service Plan pricing starts at \$166.

System 200	With Monitor & Adapter		
	Hard Disk Drives	VGA Mono	VGA Color Plus
40 MB 40ms	\$2,499	\$2,799	\$2,999
40 MB 28 ms	\$2,699	\$2,999	\$3,199
90 MB 18 ms ESDI	\$3,199	\$3,499	\$3,699
150 MB 18 ms ESDI	\$3,699	\$3,999	\$4,199
322 MB 18 ms ESDI	\$4,499	\$4,799	\$4,999

*Performance enhancements (Systems 325, 310 and 220): Within the first megabyte of memory, 384 KB of memory is reserved for use by the system to enhance performance.

4 MB configurations available on all systems. Call for pricing.



APPLICATION SOFTWARE.

We offer a complete line of software. Everything from complex CAD/CAM applications to fun flight simulator programs. All at extremely competitive prices.

OPERATING SYSTEM SOFTWARE.

- Dell Enhanced Microsoft[®] MS-DOS[®] 3.3: \$99.95.
 - Dell Enhanced Microsoft MS-DOS 4.0: \$119.95.
 - (Both MS-DOS versions with disk cache and other utilities)
 - Dell Enhanced MS[®] OS/2 Standard Edition 1.0: \$324.95.
 - Dell UNIX[®] System V/386, Release 3.2:
- Now Available. Call for details.

All prices and specifications are subject to change without notice. Dell cannot be responsible for errors in typography or photography. **Payments based on a 36-month open-end lease. †Leasing provided by Leasing Group, Inc. In Canada, configurations and prices will vary. Microsoft, MS, MS-DOS and XENIX are registered trademarks owned by Microsoft Corp. 386 is a trademark of Intel Corporation. UNIX is a registered trademark of AT&T. Dell UNIX System V is based on INTERACTIVE Systems Corporation's 386/ix. ‡Signifies trademarks of entities other than Dell Computer Corporation. †Service in remote locations will incur additional travel charges. © 1989 DELL COMPUTER CORPORATION.

DOT MATRIX PRINTERS

Printer System 800: \$699.95.

Our highest resolution text and graphics, 24-pin dot matrix printer. Draft quality at 200 cps. Letter quality at 66 cps. Parallel and serial interfaces. Wide carriage.

Printer System 600: \$499.95.

9-pin dot matrix. Draft quality at 240 cps. Near-letter quality at 60 cps. Parallel interface. Wide carriage.

Printer System 300: \$199.95.

9-pin dot matrix. Draft quality at 144 cps. Near-letter quality at 36 cps. Four standard fonts. Parallel interface. Narrow carriage.



SO HOW COME YOU NEVER CALL?

THE DELL SYSTEM 310 20 MHz 386.

STANDARD FEATURES:



- Intel 80386 microprocessor running at 20 MHz.
- Choice of 1 MB or 4 MB of RAM* expandable to 16 MB using a dedicated high speed 32-bit memory slot.
- Advanced Intel 82385 Cache Memory Controller with 32 KB of high speed static RAM cache.
- Page mode interleaved memory architecture.
- VGA systems include a high performance 16-bit video adapter.
- Socket for 20 MHz Intel 80387 or 20 MHz WEITEK 3167 math coprocessor.
- 5.25" 1.2 MB or 3.5" 1.44 MB diskette drive.
- Dual diskette and hard disk drive controller.
- Enhanced 101-key keyboard.
- 1 parallel and 2 serial ports.
- 200-watt power supply.
- 8 industry standard expansion slots.

"You will have to look far and wide to find a better price-performance package for the power user that is lurking inside you."

November 29, 1988

OPTIONS:

- 20 MHz Intel 80387 math coprocessor.
- 20 MHz WEITEK 3167 math coprocessor.
- 1 MB or 4 MB RAM upgrade kit.
- 2 MB or 8 MB memory expansion board kit.

**Lease for as low as \$135/Month.

Extended Service Plan pricing starts at \$251.

System 310	With Monitor & Adapter			
	TTL Mono		VGA Color Plus	
Hard Disk Drives	1 MB RAM	2 MB RAM	1 MB RAM	2 MB RAM
40 MB-29 ms IDE	\$3,699	\$3,898	\$4,199	\$4,398
90 MB-18 ms ESDI	\$4,199	\$4,398	\$4,699	\$4,898
150 MB-18 ms ESDI	\$4,699	\$4,898	\$5,199	\$5,398
322 MB-18 ms ESDI	\$5,499	\$5,698	\$5,999	\$6,198

DISCLAIMER: All systems are photographed with optional extras, which some computer retailers won't even recognize.





OUR SYSTEM 310 IS FASTER THAN A BAT OUT OF HELL.

If you've been looking at 386™-based computers, you obviously feel the need for speed.

Something the Dell System 310 delivers in spades.

In fact, the System 310 has more speed than even the most seasoned 386-users have come to expect. Case in point, PC Labs benchmark tests. The System 310 consistently outperformed the Compaq[®] 386/20e. Not to mention the IBM PS/2[®] Model 70-121.

Leading one reviewer to write, "It's fast enough to burn the sand off a desert floor."

For us, however, fast enough is not enough. By utilizing an Intel[®]

82385 Cache Memory Controller, page mode RAM and interleaved memory, the 310 not only delivers the aforementioned speed, but enough horsepower to do everything from CAD/CAM to mega-spreadsheets to databases the size of the Manhattan Yellow Pages.

It even has the umph to work as a network file server.

TELL US WHAT TO DO NEXT.

As much as the System 310 has to offer, it doesn't even begin to reach its full potential until after we've heard your input.

For it's only in this way that

we're able to custom configure every 310 system. To give users exactly what they need. No more. No less.

Do you do a lot of spreadsheets? There's an optional Intel 80387 or WEITEK 3167 math coprocessor available.

Storage? You can have a 40 MB hard drive. Or choose a 90, 150, or 322 MB ESDI drive.

The System 310 comes standard with 1 MB of RAM. Want more? We can add as much as 8 MB to the system board.

Still not enough? We can add another 8 MB by installing a high-speed memory expansion board. You can even run your System 310 as either a MS-DOS[®], OS/2[®] or UNIX[®] system.

The same holds true for monitors. You can choose between VGA mono with paperwhite screen, or VGA Color Plus, for high resolution colors on a larger screen.

The point here is that when you order a System 310, you not only get a 386-based system that's incredibly fast, powerful and versatile, but incredibly personal as well.

YOU CAN'T GET MORE DIRECT THAN THIS.

There are two times when it can be pure hell to deal with a computer retailer.

When you're trying to buy a new computer. And after you buy a new computer.

Because in all honesty, most computer retailers know more about margins and markups than they do about memory and monitors. So getting the advice you need isn't always easy.

Getting after-the-sale service isn't always easy either.

But when you buy from us, you

never set foot in a computer store.

Instead, you deal direct. You talk with a computer expert who can offer sound advice. Someone who can help you configure a system that not only meets your needs, but meets them for about 35% less than you'd pay a retailer.

WE COME WHEN WE'RE CALLED.

One of the things that very clearly sets a Dell system apart from other computers is not just how they're sold but how they're supported.

Overkill was one description used in a PC Week article.

Perhaps. But then, we think you'll agree, when something goes wrong, you want all the help you can get, right?

Which is why every Dell system comes with self-diagnostic software and a toll-free technical support line. We're able to solve 90% of all problems right over the phone.

The other 10% receive next-day, deskside service. Thanks to our new alliance with Xerox Corporation.

And you get all this help for a full year—whenever you need it—at no extra charge.^Δ

As you've probably guessed by now, one of the things that drives us most is customer satisfaction.



So we'd like to give you the ultimate guarantee: Try a System 310 in your office for a month. Run your toughest applications. Put it through its paces, at your pace. If you're not completely satisfied, send it back anytime



AND YOU DON'T HAVE TO GO THERE TO BUY IT.

within 30 days. And we'll refund your money. No questions asked.

MAYBE YOU SHOULDN'T BUY ONE AFTER ALL.

No matter how many reasons we give you to buy a Dell system, sometimes it makes more sense to lease one instead. Whether you need a single computer, or an entire office full, leasing is just like 100% financing. So you don't tie up working capital. Or credit lines. Of course, there can also be tax advantages as well.

And just as we can custom configure your computers, we can see to it you get a custom designed

lease plan to fit the exact needs of your business.†

It's just another example of why over half the Fortune 500 companies now own or lease Dell systems.

And why you may decide that from now on, the only place you'll ever go to buy a computer, is to the phone on your desk.



TO ORDER, CALL

800-426-5150

IN CANADA, CALL 800-387-5752
IN GERMANY, CALL 06103/701100
IN THE U.K., CALL 0800 414535

Now we're making waves with IBM®

The ALR MicroFlex 7000

*The first 25MHz
Micro Channel®
compatible*

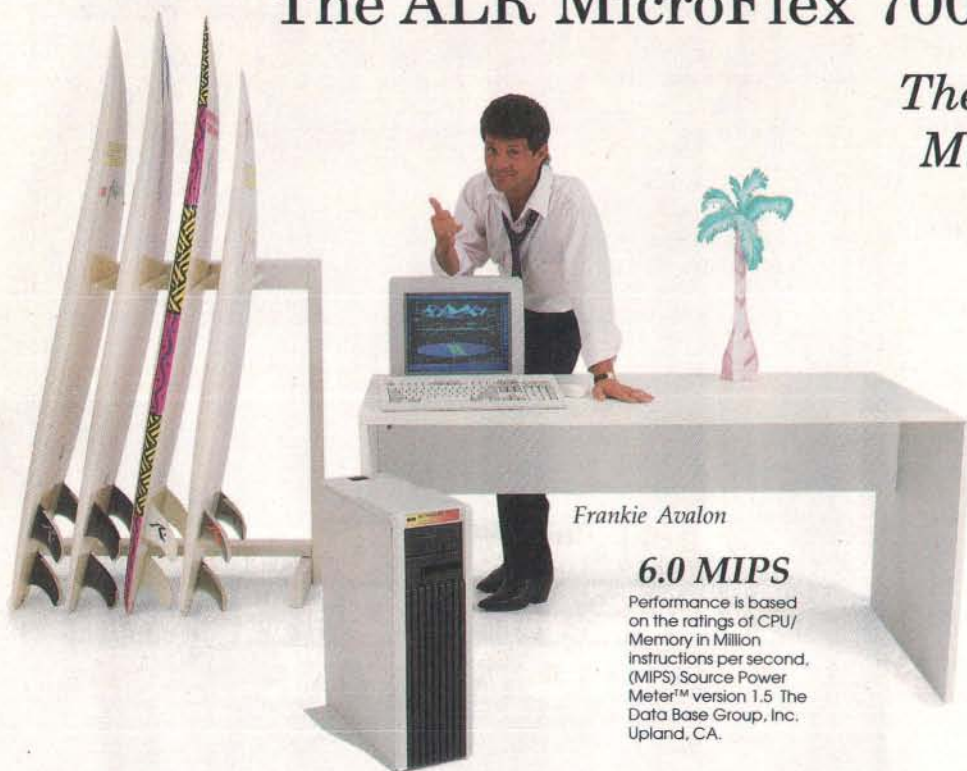

Frankie Avalon

6.0 MIPS

Performance is based on the ratings of CPU/Memory in Million instructions per second, (MIPS) Source Power Meter™ version 1.5 The Data Base Group, Inc. Upland, CA.

ALR
California
Home of the World's First 386 PC
Advanced Logic Research, Inc.

At ALR, we thrive on opportunities to beat our competitors. Our 25MHz 80386® based MicroFlex 7000 is no exception.

Unmatched performance

Our proprietary "pre-fetch" FlexCache™ design delivers the most efficient form of microcomputer processing. By combining a true 64-bit cache bus with 64-KB cache memory, performance increases 30% when compared to other 32-bit computers. And 64KB of high-speed cache memory enables you to experience the fastest

throughput for sophisticated applications. For those seeking large storage capacities, the MicroFlex 7000 gives the option of 120 or 300MB of disk storage using high-speed ESDI controllers with 1:1 interleave.

The most built-in features

The MicroFlex 7000 includes our super VGA controller with 800 X 600 graphics resolution and the sleek tower chassis offers the most internal expansion capabilities of any Micro Channel system available. Our one-

year warranty with unlimited technical support and on-site servicing available from Intel® can't be beat.

So make some waves of your own at the office with ALR's MicroFlex 7000 or any of our 33MHz systems. For more information and the name and number of your local authorized ALR reseller, please call:

1-800-444-4ALR

Advanced Logic Research, Inc.
9401 Jeronimo, Irvine, CA 92718
(714) 581-6770 FAX:(714) 581-9240

For our Canadian office: 1-800-443-4CAN
For our UK office: 44-1-399-4897
For our Singapore-Asia/Pacific office:
(65) 258-1286 FAX: (65) 258-1285

FlexCache is a trademark of Advanced Logic Research, Inc. 80386 is a registered trademark of Intel Corp. IBM and Micro Channel are registered trademarks of International Business Machines Corp. Shown with optional monitor. Prices and configurations subject to change without notice. Certified FCC class A, for business use only. Copyright 1989 Advanced Logic Research.

We're making some big waves in California

Introducing ALR's FlexCache™ 33/386Z

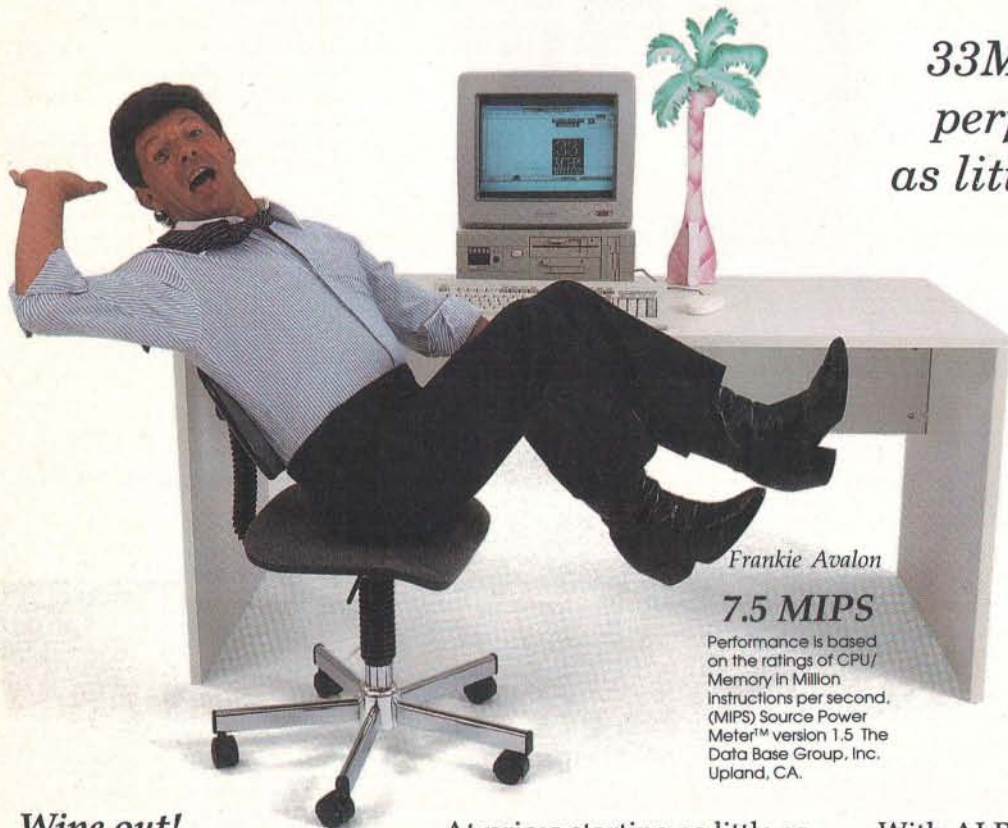

*33MHz 80386™
performance for
as little as \$3995!*

Frankie Avalon

7.5 MIPS

Performance is based on the ratings of CPU/Memory in Million Instructions per second. (MIPS) Source Power Meter™ version 1.5 The Data Base Group, Inc. Upland, CA.

ALR
California
Home of the World's First 386 PC
Advanced Logic Research, Inc.

Wipe out!

Hang on because ALR's latest addition to the FlexCache 386™ Z-family is cruising at an amazing 33MHz. That's a 20% increase in processing speed when compared to the award winning FlexCache 25386.

Fast Cache

With 32KB of cache memory, award-winning FlexCache architecture and our enhanced 16-bit super VGA controller you better be ready to move.

At prices starting as little as \$3995*, the FlexCache 33/386Z delivers the most performance for all power hungry desktop applications like CAD/CAM, desktop publishing or financial modeling at a very modest price. Of course the FlexCache 33/386Z is OS/2® compatible for tomorrow's latest generation of applications. The FlexCache 33/386Z as with all of the Z-Family comes packaged with PC-Kwik®, the award-winning disk caching utility.

With ALR's FlexCache 33/386Z you'll receive unbeatable support backed by an unprecedented three year factory warranty on the main system board, a one-year system warranty, unlimited technical support and optional on-site servicing from Intel.

For more information on the FlexCache 33/386Z call:

1-800-444-4ALR.



FlexCache is a trademark of Advanced Logic Research, Inc. 386 is a registered trademark of Intel Corp. OS/2 is a registered trademark of IBM Corp. PC Kwik is a registered trademark of Multisoft Corp. Shown with optional monitors. Certified FCC Class A, for business use only. Prices and configurations subject to change without notice. Copyright 1989 Advanced Logic Research, Inc.

PRODUCTS IN PERSPECTIVE

- 65 **What's New**
- 97 **Short Takes**
Dell 325, a quality 80386 machine
Volkswriter 4, an updated version from Lifetree
ComputerEyes, Digital Vision offers low-cost digitizing on the Macintosh
DataFinder and **ScriptView**, Paradox helps from TSR
Systems and **Farpont Systems NeuroShell**, a problem-solving program from Ward Systems Group
System Sleuth, DTG's system utility package

FIRST IMPRESSIONS

- 109 **Cover Story**
The Fastest 80386s Ever?
by Rich Malloy
Preliminary tests suggest ALR will continue to dominate the DOS performance arena.
- 114 **Greased Lightning**
by Jon Udell
The Zenith Z-386/33 features true 33-MHz performance and EISA-ready architecture.



COVER STORY

FIRST IMPRESSIONS

The Fastest 80386s Ever?

by Rich Malloy
page 109

Preliminary tests suggest
ALR will continue
to dominate
the DOS performance
arena.

REVIEWS

- 162 **Product Focus:**
4800 Bits, No Errors
by Steve Apiki and Stanford Diehl
The BYTE Lab takes a look at 17 2400-bps modems equipped with data compression and error correction.
- 175 **Big Mac Power in a Small Mac Box**
by Tom Thompson
Apple's Mac SE/30 promises to be the company's price/performance leader.
- 181 **Dead Heat**
by John Unger
To choose between the Tandon and FiveStar computers, you have to look beyond performance.
- 187 **Handy Scanners**
by Mark L. Van Name and Bill Catchings
A look at hand-held scanners from The Complete PC, DFI, Logitech, KYE, Comar Systek, and Skyworld Technology.
- 195 **Debunking 16-bit VGA**
by Bradley Dyck Kliever
Design limitations compromise potential speed improvements on 16-bit adapters.

EXPERT ADVICE

- 119 **Computing at Chaos Manor: The Hunt for Bad Sectors**
by Jerry Pournelle
Jerry goes after bad sectors on his hard disk drive.
- 137 **Applications Plus: Then and Now in Word Processing**
by Ezra Shapiro
Mac users are getting word processors with "the right stuff." Users of other systems will benefit by this trend.
- 143 **Down to Business: Just a Few Fax**
by Wayne Rash Jr.
How well do personal computer fax boards work with tabletop models?

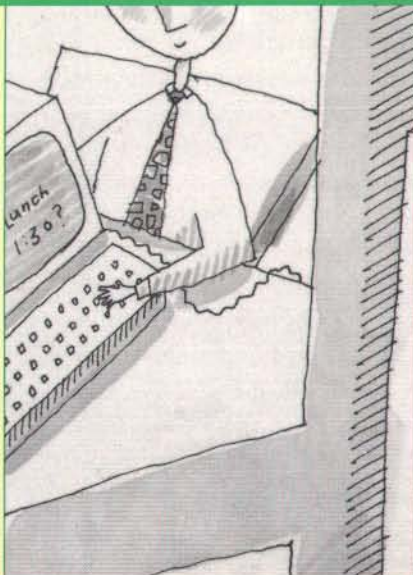

- 146 **Macinations: A Macintosh Who's Who**
by Tom Thompson
A guide for those of us who have lost track of which Mac has what.
- 151 **OS/2 Notebook: OS/2 Disk Geography**
by Mark Minasi
Mapping your hard disk under OS/2.
- 157 **Net/Works: Anatomy of a LAN Operating System**
by Mark L. Van Name and Bill Catchings
To understand LANs, you have to dissect the functional layers of the LAN operating system.

MACINTOSH SPECIAL EDITION



PAUL AVIS © 1989

- 201 Smalltalk/V Comes to the Mac**
by Ray Valdés
Digitalk's program puts pure object-oriented programming on the Macintosh.

- 205 Domesticating Microsoft Windows**
by Alex Lane
CASE:W from CASEWorks takes some of the pain out of Windows programming.

- 209 Claris CAD**
by Paul Tuten
The first CAD program from Claris may provide serious competition to VersaCAD for the Mac.

- 213 Corel Draw Shows Great Promise**
by Sue Rosenberg
This advanced drawing and graphics program could be the best yet for the IBM PC AT.

IN DEPTH

- 254 Introduction: Security**
- 257 How Safe Is It?**
by Martin Kochanski
A look at data encryption and other basic security measures.
- 267 Secret Codes**
by Asael Dror
A discussion of the fundamentals of computer cryptography.
- 275 Know Thy Viral Enemy**
by Ross M. Greenberg
It's more important than ever to guard your data and your system against infection by computer viruses.
- 285 Personal and Private**
by Peter Stephenson
The major approaches to microcomputer security, and the pick of the products in each category.
- 290 The Safety Zone**
A sampling of the security products currently available.

- 217 Editorial:**
A Source of Mac Information
by Laurence H. Loeb

- 219 Short Takes**
SuperPaint 2.0, Swivel 3D

- 225 Pushing Standard File to the Limit**
by Jan Eugenides

- 235 The Mac Interface: Showing Its Age**
by Don Crabb

- 241 A Portable Companion for the Macintosh**
by Laurence H. Loeb

- 249 Mixed Blessings**
by Jerry Pournelle

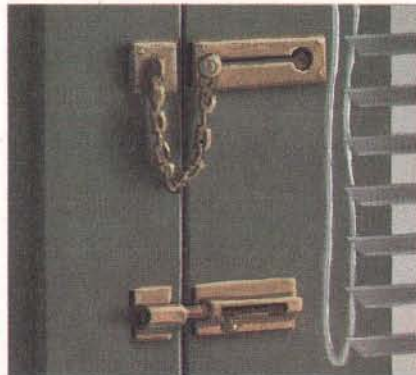

Security/254

BYTE (ISSN 0360-5280) is published monthly with an additional issue in October by McGraw-Hill, Inc. **Postmaster:** Send address changes, USPS Form 3579, and fulfillment questions to BYTE Subscriptions, P.O. Box 551, Hightstown, NJ 08520. Second-class postage paid at Peterborough, NH 03458, and additional mailing offices. Postage paid at Winnipeg, Manitoba. Registration number 9321. Printed in the United States of America.

Not responsible for lost manuscripts or photos. Opinions expressed by the authors are not necessarily those of BYTE.

Copyright © 1989 by McGraw-Hill, Inc. All rights reserved. Trademark registered in the United States Patent and Trademark Office.



Subscription questions or problems should be addressed to: BYTE Subscriber Service, P.O. Box 551, Hightstown, NJ 08520.

INTERNATIONAL SECTION
begins after page 96

FEATURES

- 294 PC-DOS: Pulling Out the Stops**
by Fetchi Chen
The latest versions of PC-DOS have features that speed up file access for applications.
- 303 An End to Dueling Rules**
by Alex Lane
A handy Prolog program called Spot helps you validate and verify rule bases.
- 313 The Ultimate Upgrade**
by Stanford Diehl
The BYTE Lab turned a standard IBM PC AT into a personal workstation—but was it worth it?
- ### HANDS ON
- 321 Under the Hood: Modern Modem Methods**
by L. Brett Glass
A look at how modems achieve their high performance.
- 327 Some Assembly Required: Directory Assistance, Part 2**
by Rick Grehan
Understanding the MS-DOS, Unix, and Macintosh HFS file-systems helps when you run into trouble.

DEPARTMENTS

- 8 Editorial: Checking Out the New 80486 and 68040**
- 13** Microbytes
- 28** Letters and Ask BYTE
- 49** Chaos Manor Mail
- 53** Book Reviews
- 379** Coming Up in BYTE
- ### READER SERVICE
- 378** Editorial Index by Company
- 380** Alphabetical Index to Advertisers
- 382** Index to Advertisers by Product Category
- Inquiry Reply Cards: after **384**

PROGRAM LISTINGS

From BIX: See **310**

From BYTEnet:
call (617) 861-9764

On disk or in print:
See card after **316**

BYTE

EDITOR IN CHIEF
Frederic S. Langa

OPERATIONS
Glenn Hartwig *Associate Managing Editor*

REVIEWS (Hardware, Software, Product Focus)
Michael Nadeau, *Associate Managing Editor*, Dennis Allen *Senior Technical Editor*, Software, Richard Grehan *Director*, BYTE Lab, Stephen Apiki *Testing Editor*, BYTE Lab, Stanford Diehl *Testing Editor*, BYTE Lab

NEWS AND TECHNOLOGY (Microbytes, What's New, Short Takes)
Rich Malloy *Associate Managing Editor*, D. Barker *Senior Editor*, News and Technology, Anne Fischer *Leit Senior Editor*, New Products, Andrew Reinhardt *Associate News Editor*

Peterborough: Roger Adams *Associate News Editor*, David Andrews *Associate News Editor*, Martha Hicks *Associate News Editor*

West Coast: Gene Smarte *Bureau Chief*, Costa Mesa, Nicholas Baran *Senior Technical Editor*, San Francisco, Frank Hayes *Associate News Editor*, Marlene Nesary *Associate News Editor*, Jeffrey Bertolucci *Editorial Assistant*, San Francisco

SENIOR TECHNICAL EDITORS
Ken Sheldon *Features*, Jane Morrill *Tazelaar In Depth*, Tom Thompson *At Large*

TECHNICAL EDITORS
Janet J. Barron, Robert Mitchell, Ben Smith, Jon Udell, Stanley Wszola

CONSULTING EDITORS
Jerry Pournelle, Ezra Shapiro, Don Crabb, L. Brett Glass, Mark Minasi, Wayne Rash Jr.

CONTRIBUTING EDITORS
Jonathan Amsterdam *Programming Projects*, Mark Haas *At Large*, Rik Jadrnicek *CAD, Graphics, Spreadsheets*, Robert T. Kurosaka *Mathematical Recreations*, Alastair J. W. Mayer *Software*, Stan Miastkowski *New Technology*, Alan R. Miller *Languages and Engineering*, Dick Pountain *Europe*, Roger Powell *Computers and Music*, Phillip Robinson *Semiconductors*, Jon Shiell *High-Performance Systems*, George A. Stewart, *Book Reviews*, Ernest Tello *Artificial Intelligence*

COPY EDITORS
Lauren Stickler *Chief*, Cathy Kingery *Copy Administrator*, Susan Colwell, Jeff Edmonds, Judy Grehan, Nancy Hayes, Margaret A. Richard, Warren Williamson

EDITORIAL ASSISTANTS
Peggy Dunham *Office Manager*, Linda C. Ryan, June N. Sheldon, Lynn Susan Valley

ART
Nancy Rice *Director*, Joseph A. Gallagher *Assistant Director*, Lisa Nardecchia *Assistant*, Jan Muller *Assistant*, Alan Easton *Technical Artist*

PRODUCTION
David R. Anderson *Director*, Virginia Reardon *Senior Editorial Production Coordinator*, Barbara Busenbark *Editorial Production Coordinator*, Denise Chartrand *Editorial Production Coordinator*, Michael J. Lonsky *Editorial Production Coordinator*

TYPOGRAPHY
Sherry Fiske *Systems Manager*, Donna Sweeney *Applications Manager*, Christa Patterson

ADVERTISING/PRODUCTION (603) 924-6448
Lisa Wozmak *Director of Advertising Services*, Linda Fluhr *Customer Service Supervisor*, Lyda Clark *Senior Account Coordinator*, Karen Cilley, Rod Holden, Wai Chiu Li *Quality Control Manager*, Jeanne Gatcombe

EDITORIAL AND BUSINESS OFFICE:
One Phoenix Mill Lane, Peterborough, NH 03458, (603) 924-9281.
West Coast Branch Offices: 425 Battery St., San Francisco, CA 94111, (415) 954-9718; 3001 Red Hill Ave., Building #1, Suite 222, Costa Mesa, CA 92626, (714) 557-6292.
New York Branch Editorial Office: 1221 Avenue of the Americas, New York, NY 10020, (212) 512-3175.
BYTENET: (617) 861-9764 (set modem at 8-1-N or 7-1-E; 300 or 1200 baud).
Editorial Fax: (603) 924-2550. **Advertising Fax:** (603) 924-7507. **Telex:** (603) 924-7861.
SUBSCRIPTION CUSTOMER SERVICE: Outside U.S. (609) 426-7070; inside U.S. (800) 525-5003.
For a new subscription—(800) 257-9402 U.S. only, or write to BYTE Subscription Dept., P.O. Box 555, Hightstown, NJ 08520.

Officers of McGraw-Hill Information Services Company: President: Walter D. Serwatka. Executive Vice Presidents: Kenneth E. Gazzola, Aerospace and Defense; Ira Herenstein, Computers and Communications; Russell C. White, Construction; Robert P. McGraw, Healthcare; Brian H. Hall, Legal. Senior Vice Presidents—Publishers: Laurence Altman, Data Communications; David J. McGrath, Engineering News-Record. Senior Vice Presidents: Robert D. Daleo, Finance; Michael J. Koeller, Human Resources. Group Vice Presidents: J. Burt Totaro, BYTE; Norbert Schumacher, Energy/Process Industries. Vice Presidents: George Elsingler, Circulation; Julia Lenard, Systems Planning and Technology.

Officers of McGraw-Hill, Inc.: Joseph L. Dionne, Chairman, President, and Chief Executive Officer; Robert N. Landes, Executive Vice President, General Counsel, and Secretary; Robert J. Bahash, Executive Vice President and Chief Financial Officer; Frank D. Penglase, Senior Vice President, Treasury Operations.

ADMINISTRATION
Donna Nordlund, *Publisher's Assistant*

MARKETING AND PLANNING
Michele Perron, *Director*
Pamela Petrakos-Wilson *Marketing Communications Manager*, Wilbur S. Watson *Marketing Services Manager*, Dawn Matthews *Public Relations Manager*, Lisa Jo Steiner *Assistant Promotion Manager*, Stephanie Warnesky *Marketing Art Director*, Sharon Price *Associate Art Director*, Julie Perron *Senior Market Research Analyst*, Faith Kluntz *Copyrights Coordinator*, Cynthia Damato *Sands Reader Service Coordinator*

FINANCIAL SERVICES
Philip L. Penny *Director of Finance and Services*, Kenneth A. King *Business Manager*, Marilyn Parker, Diane Henry, JoAnn Walter, Jaime Huber

CIRCULATION
Dan McLaughlin *Director*
Vicki Weston *Assistant Manager*, Karen Desroches *Distribution Coordinator*, Louise Menegus *Back Issues*

PERSONNEL
Patricia Burke *Personnel Coordinator*, Beverly Goss *Receptionist*

BUILDING SERVICES
Tony Bennett *Manager*, Cliff Monkton, Mark Monkton, Agnes Perry

BIX

BYTE INFORMATION EXCHANGE

DIRECTOR
Stephen M. Laliberte

EXECUTIVE EDITOR
George Bond

MANAGING EDITOR
Tony Lockwood

MICROBYTES DAIRY
D. Barker *Coordinator*, Peterborough, Rich Malloy *New York*, Gene Smarte *Costa Mesa*, Nicholas Baran *San Francisco*, Rick Cook *Phoenix*, Frank Hayes *San Francisco*, Martin Heller, Boston, Jason Levitt *Austin, TX*, Laurence H. Loeb *Wallingford, CT*, Brock N. Meeks *San Francisco*, Stan Miastkowski *Peterborough*, Wayne Rash Jr., Sue Rosenberg *Washington, DC*, David Reed *Lexington, KY*

GROUP MODERATORS
David Allen *Applications*, Leroy Casterline *Other*, Marc Greenfield *Programming Languages*, Jim Howard *Graphics*, Gary Kendall *Operating Systems*, Steve Krenek *Computers*, Brock N. Meeks *Telecommunications*, Barry Nance *New Technology*, Donald Osgood *Computers*, Sue Rosenberg *Other*, Jon Swanson *Chips*

EXCHANGE EDITOR
Laurence H. Loeb, *Macintosh Exchange Editor*

BUSINESS AND MARKETING
Patricia Bausum *Secretary*, Denise A. Greene *Customer Service*, Brian Warnock *Customer Service*, Tammy Burgess *Customer Credit and Billing*

TECHNOLOGY
Clayton Lisle *Director*, *Business Systems Technology*, ISCO., John Spadafora *Programmer/Analyst*, Wayne Power, *Senior Business Systems Analyst*

PUBLISHER/GROUP VICE PRESIDENT
J. Burt Totaro

ADVERTISING SALES
Steven M. Vito *Associate Publisher*, *Vice President of Marketing*

Sara Lyon *Administrative Assistant*

Arthur H. Kossack *Eastern Regional Sales Manager*, (312) 751-3700
Jennifer L. Bartel *Western Regional Sales Manager*, (214) 644-1111
Susan Vernon *Sales Assistant*

NEW ENGLAND
ME, NH, VT, MA, RI, ONTARIO, CANADA & EASTERN CANADA
John C. Moon (617) 262-1160

ATLANTIC
NY, NYC, CT, NJ (NORTH)
Ken Tashy (212) 512-2645

EAST
PA, KY, NJ (SOUTH), MD, W. VA, DE, DC
Thomas J. Brun (215) 496-3633

SOUTHEAST
NC, SC, GA, FL, AL, TN, VA, MS
Thomas H. Tolbert (404) 252-0626

MIDWEST
IL, MO, KS, IA, ND, SD, MN, WI, NE, IN, MI, OH
Kurt Kelley (312) 751-3740

SOUTHWEST, ROCKY MOUNTAIN
CO, WY, OK, TX, AR, LA
Karl Heinrich (713) 462-0757

SOUTH PACIFIC
SOUTHERN CA, AZ, NM, LAS VEGAS, UT
Ron Cordek (714) 557-6292
Tom Harvey (213) 480-5243

NORTH PACIFIC
HI, WA, OR, ID, MT, NORTHERN CA, NV (except LAS VEGAS), WESTERN CANADA
Bill McAfee (408) 879-0371
Christine Kopec (415) 362-4600

TELEMARKETING
L. Bradley Browne *Director*
Susan Boyd *Administrative Assistant*

NATIONAL SALES
Liz Coymann (603) 924-2518
Dan Harper (603) 924-2596
Elisa Lister (603) 924-2596

BYTE BITS (2x3)
Mark Stone (603) 924-6830

THE BUYER'S MART (1x2)
Brian Higgins (603) 924-3754

REGIONAL ADVERTISING SECTIONS
Scott Gagnon (603) 924-4380
Larry Levine (603) 924-4379
Barry Echavarria (603) 924-2574

BYTE POSTCARD DECK MAILINGS

BYTE DECK
Ed Ware (603) 924-6166

COMPUTING FOR DESIGN & CONSTRUCTION
COMPUTING FOR ENGINEERS
Mary Ann Goulding (603) 924-9281

INTERNATIONAL ADVERTISING SALES STAFF
See listing on page 381.

Founder: James H. McGraw (1860-1948). Executive, editorial, circulation, and advertising offices: One Phoenix Mill Lane, Peterborough, NH 03458, phone (603) 924-9281. Office hours: Monday through Thursday 8:30 AM-4:30 PM, Friday 8:30 AM-1:00 PM, Eastern Time. Address subscriptions to BYTE Subscriptions, P.O. Box 551, Hightstown, NJ 08520. Subscriptions are \$29.95 for one year, \$54.95 for two years, and \$74.95 for three years in the U.S. and its possessions. In Canada and Mexico, \$31.95 for one year, \$59.95 for two years, \$79.95 for three years. \$75 for one-year air delivery to Europe. \$28,800 for one-year air delivery to Japan, \$14,400 for one-year surface delivery to Japan, \$45 surface delivery elsewhere. Air delivery to selected areas at additional rates upon request. Single copy price is \$3.50 in the U.S. and its possessions, \$3.95 in Canada, \$4.50 in Europe, and \$5 elsewhere. Foreign subscriptions and sales should be remitted in U.S. funds drawn on a U.S. bank. Please allow six to eight weeks for delivery of first issue. Address editorial correspondence to: Editor, BYTE, One Phoenix Mill Lane, Peterborough, NH 03458. Unacceptable manuscripts will be returned if accompanied by sufficient postage. Where necessary, permission is granted by the copyright owner for libraries and others registered with the Copyright Clearance Center (CCC) to photocopy any article herein for the flat fee of \$1.50 per copy of the article or any part thereof. Correspondence and payment should be sent directly to the CCC, 29 Congress St., Salem, MA 01970. Specify ISSN 0360-5280/83, \$1.50. Copying done for other than personal or internal reference use without the permission of McGraw-Hill, Inc., is prohibited. Requests for special permission or bulk orders should be addressed to the publisher. BYTE is available in microform from University Microfilms International, 300 North Zeeb Rd., Dept. PR, Ann Arbor, MI 48106 or 18 Bedford Row, Dept. PR, London WC1R 4EJ, England.

BYTE and **BYTE** are registered trademarks of McGraw-Hill, Inc.

At last, an assistant that follows your directions

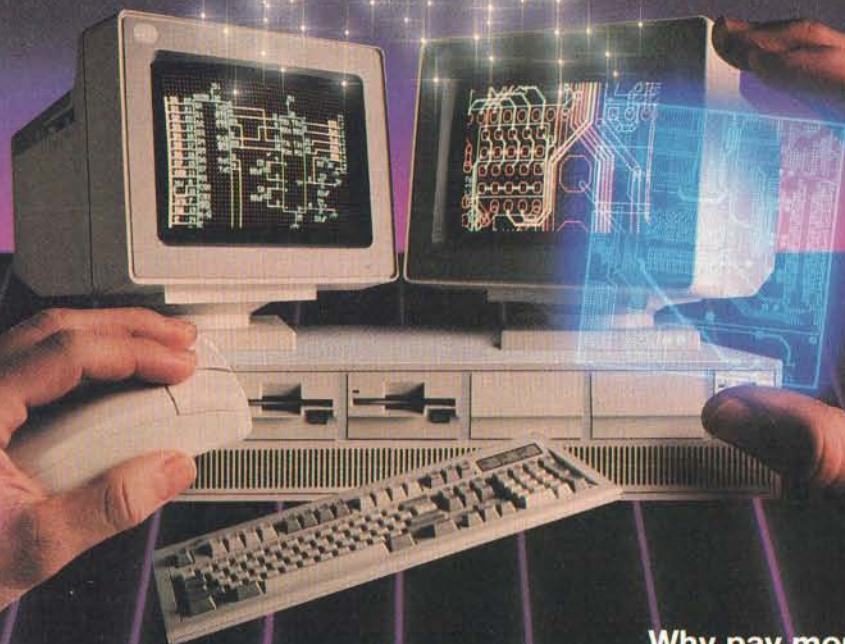

Wouldn't it be great to delegate your routing?

You can! We know your time is valuable. That's why Wintek pioneered comprehensive and affordable CAD packages for IBM personal computers. HiWIRE-Plus continued that tradition, integrating schematic-capture features and printed-circuit-artwork capabilities into one versatile package.

New autorouter.

The Autorouter for HiWIRE-Plus is powerful enough to handle the most demanding design problems, yet simple enough for a casual user. Just turn it loose on your design. It's hassle free because it works long hours, without supervision or errors.

100% autorouting.

The autorouter for HiWIRE-Plus rips-up, reroutes, and with appropriate design rules, racks up 100% completion.

- Forget gridded routers. This autorouter places vias and traces anywhere your design rules allow. With 1-mil resolution.
- Vary trace width and spacing for individual networks. Route 1, 2, 3, or more tracks between IC and connector pins.
- Set up boards from 1 to 250 layers, up to 60" x 60".
- Specify shape, size, and type of vias, layer-by-layer: through-hole, blind, buried, micro. Specify via types for individual networks.
- Use fewer vias and layers than comparably priced autorouters.
- For use on your IBM PC, XT, AT, PS/2, or compatible with 640K RAM.

Why pay more for a 100% autorouter?

Compare the features and performance to packages costing five times more. HiWIRE-Plus and the Autorouter for HiWIRE-Plus sell for \$895 each. Both have a no-nonsense, 30-day money-back guarantee. With unlimited, toll-free, no-charge technical support.

Let HiWIRE convince you that it makes a great assistant. Call us toll-free at (800) 742-6809 today and put HiWIRE-Plus and the Autorouter for HiWIRE-Plus to work for you tomorrow.



Wintek Corporation
1801 South Street
Lafayette, IN 47904-2993
Fax: (317) 448-4823
Phone: (317) 742-8428 or

(800) 742-6809

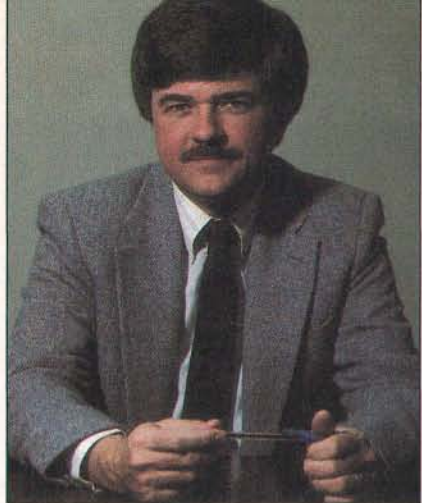

CHECKING OUT THE NEW 80486 AND 68040

A first look at these two new chips reveals amazing similarities and strange differences

At Spring Comdex in Chicago in April, Intel finally took the wraps off its long-awaited 80486, just days after Motorola announced its latest powerhouse, the 68040. (For additional details on both of these new chips, see our Microbytes story on page 13.)

Both chips were worth waiting for. They are blazingly fast (with reported speeds in the low to mid teens of million instructions per second), both contain roughly 1.2 million transistors, both are packaged in ceramic pin-grid array carriers of roughly the same size (slightly larger than the current 80386 and 68030 carriers), and both employ similar internal architectures: They each combine several functions that previously had to be handled by separate chips.

You can think of the 80486 as a device that combines an enhanced 80386 CPU, an enhanced 80387 FPU, a memory management unit, and an 8K-byte cache and controller—all on one chip. Similarly, the 68040 places on one chip an enhanced 68030 combined with a 68882-compatible FPU, an MMU, and separate data and instruction caches.

But when you step back from the specifications, some basic differences appear—differences that may have more to do with Motorola and Intel than with the chips themselves.

For example, a number of the companies that were at Comdex already had early samples of the 80486: We saw two working 80486-based machines and one separate 80486 motherboard. Although Motorola beat Intel's announcement by a

few days, we've seen no working 68040 computers, and not even any sample chips. It's strange—and a little disturbing—to see how far along 80486 system development is and to see nothing on the 68040 side. We'll bring you news of 68040 systems as soon as we learn of them, but for now, let's look at what does exist.

IBM's 80486

The Microbytes story on page 16 provides details of an 80486-based PS/2 Model 70 that IBM Entry Systems President James Cannavino showed me less than 24 hours after Intel's official rollout of the 80486. The story also tells you how IBM did it—but the bottom line is that IBM engineers had an 80486 running DOS, OS/2, and AIX in an amazingly short time. Best of all, they ran roughly twice as fast as on a similarly clocked 80386 machine.

While this was a "technology demonstration" and not a product announcement, it still represents an engineering tour de force for both Intel and IBM: Despite the fact that we were seeing a raw prototype unit running a brand-new prototype chip, everything ran smoothly. The prototype daughtercard itself was uncommonly neat, clean, and almost jumperless. (I've seen messier boards in off-the-shelf hardware from some other manufacturers.)

Intel's Box

Intel also demonstrated an 80486-based computer but took a very different tack: It showed its new chip powering a generic AT box from which all identifying markings had been removed. Because the AT-style box lacked a separate CPU carrier, Intel installed the 80486 via two large add-on boards: a daughterboard that lay flat, parallel to the motherboard, and a "granddaughterboard" (which actually carried the 80486). The granddaughterboard plugged into the daughterboard; the daughterboard plugged

into the AT's motherboard. We're not talking slick here.

Like IBM, Intel hastened to point out that its 80486 system was not a real product, but merely a technology demonstration. But while IBM's demonstration was clean and well developed, Intel's was large and clunky. Also, it was heavily populated with custom PLDs (programmable logic devices) and with numerous empty sockets.

This was all a little surprising. Since Intel provides motherboards and entire systems for OEMs, it shouldn't have been all that difficult for the company to produce something closer to IBM's approach. It's hard to reconcile the elegance of the chip itself with the raw quality of Intel's demonstration system. It's also hard to understand in light of what Cheetah was able to do.

Texas Gamblers

Cheetah—a small Texas company known for its high-speed motherboards—took a wild gamble on the 80486. Unlike IBM, it had no inside track to confidential prerelease information (after all, IBM owns a piece of Intel). Unlike Intel, Cheetah doesn't own the chip specification. But Cheetah does have a ton of expertise and a fair helping of Texas-size confidence. It designed a motherboard for the 80486 based on nothing more than its best guesses as to what the chip would be.

Its gamble paid off, and the motherboard that Cheetah brought to Comdex was well suited for the 80486. About the time you read this, the company's first production 80486 motherboards should be leaving the factory, which gives Cheetah a shot at being the first company with a marketable 80486 motherboard. BYTE is first in line to get a unit, and we'll report our test results as soon as we possibly can.

—Fred Langa
Editor in Chief
(BIX name "flanga")

INTERACTIVE
386/ix

**The Choice is Clear.**

UNIX® Checklist

for 386 systems

- Leading Edge Technology:** First to bring UNIX to 386, first to bring MS-DOS to UNIX, first with X Window, NFS and host-based TCP/IP for the 386.
- Optimized For Business:** Mature and popular environment supporting thousands of commercial applications. Backed by comprehensive support and training.
- Standard:** UNIX System V certified. Committed to meet emerging POSIX and X/OPEN standards. MS-DOS® and XENIX® applications run, too.
- Outstanding Industry Track Record:** UNIX technology supplier to IBM, Int AT&T, Prime, NCR, Microsoft, Wang, Apollo and others.
- Excellent Price/Performance:** pricing and...

INTERACTIVE

A KODAK COMPANY

1-800-346-7111

INTERACTIVE
Systems Corporation
2401 Colorado Avenue
Santa Monica, CA
90404

UNIX is a registered trademark of AT&T
386/ix is a trademark of INTERACTIVE
Systems Corporation.
MS-DOS and XENIX are registered
trademarks of Microsoft Corporation.

©1988 INTERACTIVE Systems Corporation

DISCOVER COMPLETE

Gateway 2000 set out 4 years ago with one goal in mind. To be the #1 direct we knew that we had to provide "complete customer satisfaction". As we see quality equipment at the best price available anywhere. The customer has addition to this we had to build a reputation for incredible service that was confidently say that we have achieved these goals. Although we are not yet have thoroughly checked out the competition, and suggest that you do the GATEWAY 2000 computer system. And we can guarantee you that we will system. If you won't take our word for it take a look at what our customers chosen by BYTE magazine for their annual BYTE awards. Our 386-20 was Call us toll-free to discover "complete customer satisfaction".

"We are very happy that our system is at the top of the stack in both price and performance, but it is your courteous service that is uncontested by the competition."

— Pierce Haviland — Kingston, NY

"Overall, I feel that your product is outstanding and your service has been excellent."

— Eric Shogren — Stonington, CT



12 Mhz 286 VGA

2 Megs RAM
1.2 Meg 5 1/4" Drive
1.44 Meg 3.5" Drive
40 Meg 28ms SCSI Drive
10 Mbits/Sec DTR
16 Bit VGA Board
14" VGA COLOR Monitor
1 Parallel/2 Serial Ports
101 Key Keyboard
MS DOS 4.01

\$2295.00

16 Mhz \$2395.00

20 Mhz \$2495.00



25 Mhz 386 VGA

4 Megs RAM
1.2 Meg 5 1/4" Drive
1.44 Meg 3.5" Drive
150 Meg 16.5 ms ESDI Drive
10 Mbits/Sec DTR
16 Bit VGA Board
14" VGA COLOR Monitor
1 Parallel/2 Serial Ports
101 Key Keyboard
MS DOS 4.01

\$4495.00

(Call for 33 Mhz Option)

20 Mhz 386 VGA

1 Meg RAM
1.2 Meg 5 1/4" Drive
1.44 Meg 3.5" Drive
80 Meg 28ms SCSI Drive
10 Mbits/Sec DTR
16 Bit VGA Board
14" VGA COLOR Monitor
1 Parallel/2 Serial Ports
101 Key Keyboard
MS DOS 4.01

\$2995.00

(Upgrade to 4 Megs \$500)



All systems have a 30 day Money Back Guarantee and 1 Year Warranty.
Due to the Volatility in the DRAM Market all prices subject to change.

CUSTOMER SATISFACTION

marketer of micro computers in the nation. In order to attain this lofty goal it, to achieve "complete customer satisfaction" we had to supply the best to feel that he or she received most value for their hard earned money. In completely unheard of in the mail-order business. At this point we can the largest company in the market we strongly feel that we are the best. We same. We want you to feel entirely confident of your decision to purchase a do everything in our power to keep you satisfied after you receive your are saying about us. In addition to this we were the only "clone" company chosen out of the hundreds of products they reviewed for it's overall value.

THE POWER USER'S DREAM MACHINE

Gateway 2000 Inc. of Sgt. Bluff, Iowa in a cooperative effort with Mylex Corporation of Fremont, CA announces a 33 MHz 80386 machine designed to offer state-of-the-art performance at an incredible price.

INTEL 80386-33 PROCESSOR
128K HIGH SPEED CACHE RAM
4 MB SYSTEM RAM (EXPANDABLE TO 32 MB)
2-32 BIT SLOTS AVAILABLE
VARIABLE BUS SPEEDS (6, 8, 10, 16 MHz)
SUPPORT FOR WEITEK AND 80387
8 LAYER U.S. MOTHERBOARD
1.2 MEG 5 1/4" FLOPPY DRIVE
1.44 MEG 3.5" FLOPPY DRIVE
150 MEG ESDI HARD DRIVE 16 MS
1 PARALLEL/2 SERIAL PORTS
16 BIT VGA BOARD W/512K RAM
NEC 3-D MONITOR
1024 X 768 RESOLUTION W/16 COLORS
MS DOS 4.01/GW BASIC
1 YEAR WARRANTY
2 YEAR WARRANTY ON MOTHERBOARD

\$6995.00



BENCHMARK RESULTS

Norton Utilities Ver. 4.0 SI	42.2
Power Meter MIPS	7.748
Landmark Software LANDMARK	54.1
PC Mag 80386 INSTRUCTION MIX	1.71

Gateway 2000

P. O. Box 2000

Sgt. Bluff, IA 51054

800-233-8472

712-943-2000





Creative License.

If you've ever tried to combine windows, menus, forms, and text entry to create an effective user interface, you know how challenging it can be.

Perhaps you've turned to a third-party library for help. Only to run into restrictions, limitations, and dead ends. So you had to compromise your design. Or modify the library source code. Or start over.

Which is precisely why we designed Vermont Views™, the new generation of Windows for Data®, the best-selling C library for user interfaces.

Vermont Views offers unbridled, unrestricted creative license.

The Human Interface Of Your Dreams

Vermont Views offers an unparalleled set of interface building blocks that you can combine in unlimited ways:

- Menus can be created in any style you choose, made scrollable vertically and horizontally, and nested to any level. Features include n-th character selection, checkmarks, and unavailable items.

- Data entry forms can be bigger than their display windows, have scrollable regions for the entry of variable lines of items, lists of choices for data entry, context sensitive help, and special decimal, date, time, and toggle fields.

- A mini word processor can be attached to a field window in a form or

used as a pop-up note taker.

You're In Charge

Because you can write and attach functions to the beginning and end of menus, forms, fields, and to keys, you're always in control.

Use these control functions to call up subsidiary forms and menus, change field values and the active field, exit or abort a form, do almost any task you can imagine.

All interactive capabilities of Vermont Views use a unique system of accessible keytables, so you can easily change or disable key assignments - even add to the functions provided for menus, forms, text entry, and windows.

One For All

Vermont Views is available for DOS, OS/2, UNIX, XENIX, and VMS. Maintain the same user interface on all of these operating systems with the same source code.

Vermont Views provides international portability as well, with full support for IBM international characters, flexible date and time formats, and changeable decimal and thousands separators.

Novice Or Expert

Despite its depth and flexibility, Vermont Views is easy to learn and use. Each major facility is covered in a single, self-

contained section of the manual, so you only need to learn capabilities as you use them.

To help you become an expert in no time, we include a free copy of the Norton Guides™ Engine and our own comprehensive Pop-Up Reference™. You'll have immediate, on-line access to function names, reference pages, structures and tables.

No-Time-Limit Guarantee

We've only touched on a fraction of what makes Vermont Views special. The only way to know it is to use it.

Try Vermont Views on your hardest problems.

For as long as you want. At no risk.

If not fully satisfied, return for a full refund. Anytime.

To Order Today Call 1-800-848-1248

Call to order Vermont Views today. And we'll send your "creative license" right away.

Prices: DOS \$395; with Source \$790. UNIX, XENIX, VMS, OS/2 please call.



Vermont
Creative
Software

Pinnacle Meadows, Richford, VT 05476

800-848-1248, 802-848-7731 Fax: 802-848-3502 Telex: 510-601-4160 VCSOFT

MICROBYTES

Staff-written highlights of developments in technology and the microcomputer industry, compiled from Microbytes Daily and BYTEweek reports

80486, 68040 Open New Season of CPU Power

This year, spring brought more than the return of baseball to the land. Right about the time of opening day at ballparks all across the country, two division champions in the personal computer industry, Intel and Motorola, introduced microprocessors that could triple the performance of IBM PC-compatible systems, Macintoshes, and Unix workstations as well. The new 80486 and 68040 processors from Intel and Motorola are certainly significant landmarks in terms of processor design. But before getting too excited about nitro-burning desktop computers, remember that there's some question about whether other system components, such as memory, can keep up with the blazing clock speeds. It takes more than a fast CPU to make a fast computer.

After more than a year of speculation, Intel finally released details of its 80486 processor at Comdex in Chicago. The newest member of the 8088 family of processors will be approximately two to four times faster than the 80386. Some microprocessor experts say the 80486 is the first complex instruction-set computer (CISC) chip to challenge RISC chips in performance. Intel also officially introduced the 33-MHz version of the 80386, scheduled to be available later this year. Computer makers from ALR to Zenith announced—in harmony, as it were—that they will offer personal computers using the new chip.

The 80486 handles several functions that today are performed by separate chips. It's a combination of an enhanced 80386 processor, an enhanced 80387 FPU, a memory management unit, a cache controller, and an 8K-byte cache.

The 80486 could have a profound impact on the high end of the personal computer industry. In addition to vastly increasing the performance of these systems, the new chip should also lessen the amount of space required on the systems' motherboards. Further into the future, hardware designers could take advantage of the 80486's capabilities for parallel processing, which will

increase performance further.

Fortunately for users, the performance increase of the 80486 is not obtained at the expense of compatibility. Intel engineers said in interviews with BYTE that the 80486 is completely compatible with both the 80386 and the 80387 FPU. The 80486 does have some new instructions, but these are designed to be "transparent," so that 80486-oriented software should run on 80386-based machines as well, but perhaps not quite as quickly.

The new 80486 instructions increase performance significantly, but even when working with 80386 instructions, the 80486 performs much faster than its older relative. With its on-chip equivalent of an 80387 and an 8K-byte cache, along with a RISC-style design, the 80486 running at the same clock speed as an 80386 is roughly three times as fast. For example, Intel claims that the 80386 at 25 MHz runs the Dhrystone benchmark at 13,000 Dhrystones per second, while a 25-MHz 80486 runs a phenomenal 37,000 Dhrystones per second—as fast as some RISC chips.

Intel has slated several versions of the chip. The first two, a 25-MHz and a 33-MHz version, will run at 15 to 20 VAX MIPS, according to Intel.

Motorola Counters with 68040

But before Intel could announce the 80486, arch rival Motorola released details—although sketchy—about the architecture of its upcoming 68040 processor. Like the 80486, the 68040 combines CPU, FPU (its instructions are code-compatible with the 68882 FPU), and cache on a single chip. According to Motorola, the 68040 contains 1,200,000 transistors; the 80486 has 1,160,000. But the company was vague about several technical details and would not say when the chip will ship or how much it will cost.

Like the 68030, the new chip will use a Harvard-style architecture—that is, separate data and code buses. Each bus also has its own on-chip cache, which improves performance. On the 68030, these caches are 256 bytes;

continued

NANOBYTES

At the same time that Intel announced details of its 80486 CPU, the company also introduced 33-MHz versions of the 80386 CPU, the 80387 FPU, and the 80385 cache controller, as well as low-power versions of the 80386SX and 80387SX that can slow down to 2 MHz to conserve energy (but they're not fully static, so you can't actually stop the clock).

Prime Computer (Natick, MA) says it will help Intel with an ECL (emitter-coupled logic) implementation of the 80486, which the company expects could be used in multiple modules on a single mainframe computer and perform at a speed of 120 MIPS. Prime said it hopes to have the self-cooling package done by 1992.

Amidst the spring barrage of new chips from Intel and Motorola, **Harris Semiconductor** (Melbourne, FL) introduced a 25-MHz model of the **80286**. The Harris chip is designed to compete with 25-MHz versions of the 80386. Harris says that, depending on the software the chip is running, the 80286 can run as much as 20 percent faster than a 25-MHz 80386. The chip costs \$142 in batches of 1000.

Apple has a new LaserWriter driver (LaserWriter 6.0) that supports color PostScript printers, such as those from QMS and Tektronix. For the first time, Apple is supporting laser printers that don't bear the mark of the bitten, rainbow-striped apple. The new driver, announced at the recent NCGA conference, also supports halftones and gray-scale images on black-and-white PostScript printers.

Toshiba (Irvine, CA) has prototyped an 8-megabyte memory module that uses Toshiba

continued

NANOBYTES

4-megabit DRAM chips. With the memory module, a T5200 portable computer can be outfitted with a total of 14 megabytes. The 4-megabit chips were scheduled to start shipping in April, according to a spokesperson.

Developers interested in working with the **Open Software Foundation's graphical user interface**, Motif, can now order a copy of the Preliminary Functional Description. The 200-page document, which costs \$30, covers such components as the window manager and the toolkit. Phone the OSF Advance Information Desk at (617) 621-8835.

How to save shelf space: **Digital Equipment Corp.** officials said at the CD-ROM conference that they have accomplished the goal set for them by **Bill Gates** last year. While not naming DEC, Gates asked that a particular set of documentation that takes up 15 feet of shelf space be put on a CD-ROM disk. The VMS 5.1 documentation and DECwindows manuals are now available on a disk for \$895. DEC plans to move its entire documentation library to CD-ROM.

The number of **CD-ROM readers** out there is 171,000, according to a study released by research firm InfoTech. That might be low compared to the number of Elvis sightings in the past year, but it's four times higher than the number of CD-ROM systems in 1987. "CD-ROM is a publishing medium that has come of age," said InfoTech president Julie Schwerin. Last year, about 580 titles were available on CD-ROM, she said.

While demonstrating the new versions of **Lotus 1-2-3**, a Lotus official was asked about the possibility of Lotus doing a **Windows version** of the spreadsheet program. "We don't see Windows as a long-term graphical interface for the masses," he said.

Sony (San Jose, CA) is offering a new **DAT** (digital audio tape-

continued

Motorola representatives would say only that the caches are bigger on the 68040. The chip will also have bus-snooping capability, which is helpful in a multiprocessor environment where several processors can operate on the same set of data.

Motorola also announced a 50-MHz version of its 68030 CPU. The news was designed to upstage Intel's anticipated announcement of 33-MHz versions of the 80386 CPU, 80387 FPU, and 82385 cache controller.

By moving the FPU back onto the main processor chip, both Intel and Motorola are turning the clock back. The two companies are gradually returning us to the days before the existence of a separate FPU. This could be a good move, since the FPU has had the effect of dividing users into haves and have-nots—those with a numeric coprocessor and those without. For hardware developers, that means no more empty coprocessor sockets taking up space; for software developers, it means they can write code for one system without worrying whether the user will or will not have the FPU. Of course, the other advantage of having the FPU on the same chip as the CPU is that it greatly reduces the distance (and time) that signals have to travel between these two units, resulting in a significant boost in performance.

Along with its own on-chip FPU, the Intel 80486 also has its own cache controller and an 8K-byte on-chip cache. Although the cache is rather small, Intel claims that with most software, the cache hit rate (the percentage of times the processor will access memory that has already been moved into the cache) is 90 percent.

RISC, Caching Contribute to Gains

Intel also says it has employed high-speed RISC techniques for the most frequently used operations. For example, when code and data are already in the cache, simple instructions that move data take just one clock cycle to execute. On the 80386, the same instructions require two to four cycles. And the 80486's instructions for calling subroutines are three times faster than those on the 80386.

The cache is also involved in the 80486's parallel-processing capabilities. When several processors are present, each with its own memory cache, it's difficult to be sure that each cache accurately represents the current state of memory. To accomplish this,

the 80486 cache controller watches the bus to determine when the other caches are accessing conflicting areas of memory. Other multiprocessor features of the chip include multilevel cache support, burst bus capability (a 32-bit burst every clock), and a standardized multiprocessor architecture that's designed for any combination of processors, including the 80486, the 80386, and Intel's new RISC chip, the 80860.

The 80486 shares substantial technology with the high-speed graphics-oriented 80860. Although the 80486 doesn't have the 80860's instruction pipelining features, you can increase the performance of the chip by arranging the instructions in certain ways. Intel said it will make available a compiler that is optimized for the 80486 and that will rearrange instructions in order to speed up performance. Even though the 80386 and 80486 are "code-compatible," some programmers will have to choose between optimizing for the 80386 and optimizing for the 80486. According to Intel, programmers will get a 10 percent to 15 percent performance boost from optimizing for the 80486.

Intel officials said they expect to see 80486-based machines replacing the 80386 in high-performance systems such as file servers, but they said they see many 80486s going into multiprocessor systems as well.

Advance samples of the 25-MHz 80486 should be available to hardware developers by this fall, with full production by the end of the year, Intel officials said. The 33-MHz version is scheduled to be available in samples at the end of this year, with a 40-MHz version in 1990 (and 50- and 60-MHz versions within the next couple of years). It will cost \$950 for a 25-MHz 80486 (presuming you buy them a thousand at a time). That's not much more than the combined cost of an 80386, an 80387, a cache controller, and an 8K-byte cache—and it offers three times the performance.

The performance of the new processors is indeed impressive. The problem now is coming up with other system components that can keep up with the CPU. This means faster memory and disk I/O. Advances are being made in these areas, but not to the extent that microprocessors are changing. Clock speed is just part of the equation.

continued

AST Takes 33 MHz, 386™ Power One Step Further.



From left to right:
33 MHz, AST Premium 386/33
25 MHz, AST Premium 386/25
20 MHz, AST Premium/386C
16 MHz, AST Premium 386/16
16 MHz, AST Premium
Workstation/386SX

When you buy the 33 MHz, AST Premium® 386/33, you aren't just getting the fastest technology available in a desktop computer. You're getting it AST style.

Which means that in keeping with the AST 386 family tradition, we've packed several speed-enhancing features into the AST Premium 386/33. Such as zero wait-state cache, support for up to 36 MB of memory, support for 80387 and Weitek 3167 coprocessors, 16 ms hard drive access and more.

As a result, you'll be able to tackle a broad range of performance-sensitive and power-hungry applications both in single and multiuser environments, such as 3-D animation, geophysical simula-

tion, regression analysis, CAD/CAM and LAN file service.

And like the rest of the AST 386 family, the AST Premium 386/33 is backed

by the same commitment to quality, industry-standard compatibility and support that makes

AST a computer industry leader.

Of course, if you don't need quite so much power, AST offers several high-performance 386 and 386SX™ systems. Such as the 25 MHz, AST Premium 386/25 and the 20 MHz, AST Premium/386C for racing through technical and business applications.

And for an affordable entry into 386-CPU computing, try our true 32-bit, cache-

based 16 MHz AST Premium 386/16 and the small footprint AST Premium Workstation/386SX.

For name-brand systems that provide unbeatable performance, step up to AST. For more information, call us at (714) 863-0181 and ask for operator BB41, or use our Bulletin Board Service Number (714) 852-1872.

AST, AST logo and AST Premium registered trademarks AST Research, Inc. 80386 and 80386SX trademarks Intel Corp. All other product and brand names are trademarks and registered trademarks of their respective companies. Copyright © 1989 AST Research, Inc. All rights reserved. AST markets products worldwide — in Europe and the Middle East call 44 1 568 4390; in Japan call 81 3 818 0710; in the Far East call our Hong Kong office 852 5 806 4333; in Canada call 416 826-7514.

AST Premium 386/33	AST Premium 386/25	AST Premium /386C	AST Premium 386/16	AST Premium Workstation /386SX
51.7	39.4	30.8	23.3	23.2

Landmark Software v. 1.1 benchmarks — a generalized index used to compare one machine to another. The higher the number, the better.

NANOBYTES

recording system) drive to OEMs. The SDT-1000 has a storage capacity of 1.3 gigabytes, a data transfer rate of 183K bytes per second, and an average access time of 20 seconds, Sony said. The 5¼-inch unit comes with a SCSI connector. Final prices weren't set as we went to press, but the DAT drives will probably cost computer makers about \$2000 each.

RoboMac: MacMotion (Medway, MA) has developed a nine-axis robot that runs under **HyperCard** control. The robot, encased in a 19- by 5-inch enclosure, is suitable for materials handling, inspection, and assembly. Design load is 10 pounds, and gripper speed is up to 150 inches per minute. "This type of robot has sold for \$300,000 in the past, but we are going to reduce the cost by an order of magnitude to \$30,000," said a company official. "We used the HyperCard environment to allow for ease of programming of the system." Meanwhile, at the recent PITTCON show in Atlanta, **Sartorius Instruments** (McGraw Park, IL) had at its booth a droid-like two-legged robot with a Mac SE in its head.

RoboDoc: Speaking of robots, **Carnegie-Mellon University** (Pittsburgh, PA) this fall will open a doctoral program in robotics. The curriculum will cover robotic cognition, perception, and motion, as well as the integration of automatons into manufacturing situations.

Today's mass of **incompatible data** and communications standards is like "a grandmother's attic of information on a scale never before imagined," said **AT&T CEO Robert Allen** at the recent Interface '89 show in New York City. "We've got to clean it up," he said. He compared the computer industry to the railroad, construction, and auto industries, saying that those businesses couldn't have flourished without standardization. "Standards are the key to reaping the full harvest of our technology," he said.

continued

IBM Shows PS/2 Powered by Intel's 80486

It didn't take IBM long to put together a machine using Intel's 80486 processor. At a briefing during Comdex, IBM Entry Systems president James Cannavino showed a PS/2 Model 70 modified with an 80486 chip. IBM engineers got the Intel pin-out specs and designed a new CPU carrier, which IBM calls the "processor complex platform," a little daughtercard that normally carries the 80386 and 80387 chips and static RAM. "The 80486 is an elegant sweep of those separate chips into a single chip," Cannavino said. The engineers had to do some "minor" tweaking of the BIOS, he said, but it took them only three days to get the 80486 system running after they received chips from Intel.

IBM has tested the new Intel CPU with DOS, AIX, and OS/2 and found a doubling of speed between the 25-MHz 80386 and 25-MHz 80486 in routine applications not optimized for the 80486, Cannavino said. He noted

that the current chips have problems but that a revision is due soon.

The daughtercard upgrade isn't likely to be a product itself, Cannavino said, because 80486-based bus-master cards are in the works. The demonstration was what IBM calls a "technology announcement." Nevertheless, it's clear that IBM isn't wasting any time getting ready to produce an 80486 system. Cannavino hinted that IBM's first 80486-based PS/2 would ship early next year. "But that doesn't mean at all that we'll be skipping 33-MHz 80386s."

Cannavino emphasized that the real benefit of the next generation of chips will be the high-performance graphical user interfaces that they make possible. Asked if he thought the Apple-Microsoft lawsuit might stall development of those interfaces, Cannavino told BYTE, "I've looked at the issues thoroughly, and I'm not making any changes in IBM's plans for Presentation Manager."

New 32-Bit QuickDraw Means Better Mac Color

Macintosh graphics will become more colorful and application developers will have a bigger paintbox now that Apple Computer has released its 32-bit extensions of Color QuickDraw, the imaging model used by the Mac for displaying color on the screen. The new 32-Bit QuickDraw, which will run on all 68020- and 68030-based Macs (SE/30, II, IIX, and IICX), establishes a new standard for color applications on the Macintosh, enabling the computer to display more than 16 million colors simultaneously on the screen. (The current 8-bit Color QuickDraw technique lets the computer display 256 colors.) This wealth of colors will mean that developers can build applications that generate images with natural, photographic-quality color. Color scanned images will appear virtually unchanged on the screen.

The new QuickDraw consists of a set of files that you simply copy to the System Folder. You have to have System 6.0.3, but no ROM upgrades are required. While the files will usually be bundled with 32-Bit QuickDraw applications, you can get them from Apple dealers or from the Apple Developers Association (Santa

Clara, CA). At least 2 megabytes of RAM is recommended, since 32-Bit QuickDraw takes up 120K bytes of memory, and most color applications require a lot more.

While 32-Bit QuickDraw does indeed use one 32-bit word (4 bytes) to describe each pixel on the screen, it uses a maximum of 24 bits to specify the color attributes of the pixel (8 bits for red, 8 bits for green, and 8 bits for blue). The 8 bits left over (called the "alpha channel") are currently unspecified and can be used by application developers for their own purposes, such as adding a transparency mask allowing objects to show through other objects on the screen. Because the entire definition of the pixel is contained within one 32-bit word, or "chunk," of memory, 32-Bit QuickDraw is called a "chunky" color model.

In 24-bit addressing mode, 32-Bit QuickDraw supports the display of more than 16 million colors simultaneously on the screen. It also supports 16-bit, 8-bit, 4-bit, 2-bit, and 1-bit addressing modes, which means that 32-Bit QuickDraw can run on any video board on a Mac II, IIX, or SE/30.

continued

SEE THE FULL SPECTRUM

SOTA VGA/16 Delivers It.

SOTA Technology — a pioneer in accelerator board technology — now brings high-speed, high-resolution graphics to your PC.

SOTAVGA/16 is designed to optimize the performance of all popular software. Its industry leading 16-bit memory and BIOS interface, is designed to take advantage of the extra performance offered by 286/386 machines. In fact, speed increases of up to 400% faster than the IBM VGA are realized.

In addition to being faster, SOTAVGA/16 also gives you more colors and resolution than IBM VGA. Base configuration includes 256 K of video memory, enough memory for 800 × 600 resolution with 16 colors. Plus, it's upgradeable to 512 K — simply plug in the extra memory chips. With 512 K you get 1024 × 768 resolution in 16 colors or 800 × 600 in 256 colors. Software drivers are included for all your popular programs.

The SOTAVGA/16 is 100% VGA hardware compatible and runs current programs such as Windows 386 and OS/2 flawlessly. It is also hardware compatible down to register level with all pre-VGA standards such as EGA, CGA, MDA and Hercules. This means that virtually all existing software will run with the SOTA VGA/16 — and it insures compatibility with future software.

SOTAVGA/16 has two output connectors for full analog and digital monitor support — not just analog, as some manufacturers offer. And, since many of today's programs require a mouse, SOTA offers this option right on the board. No longer do you have to compromise an extra slot or sacrifice one of your COM ports to install a mouse. Simply plug it into SOTAVGA/16.

So whether you want to add pizzazz to your business presentation graphics or view your spreadsheet in 132 columns, SOTAVGA/16 is the right choice.

After all, everything looks better in VGA.

For more information on the SOTA VGA/16 please call 800-237-1713.
In CA 408-745-1111.

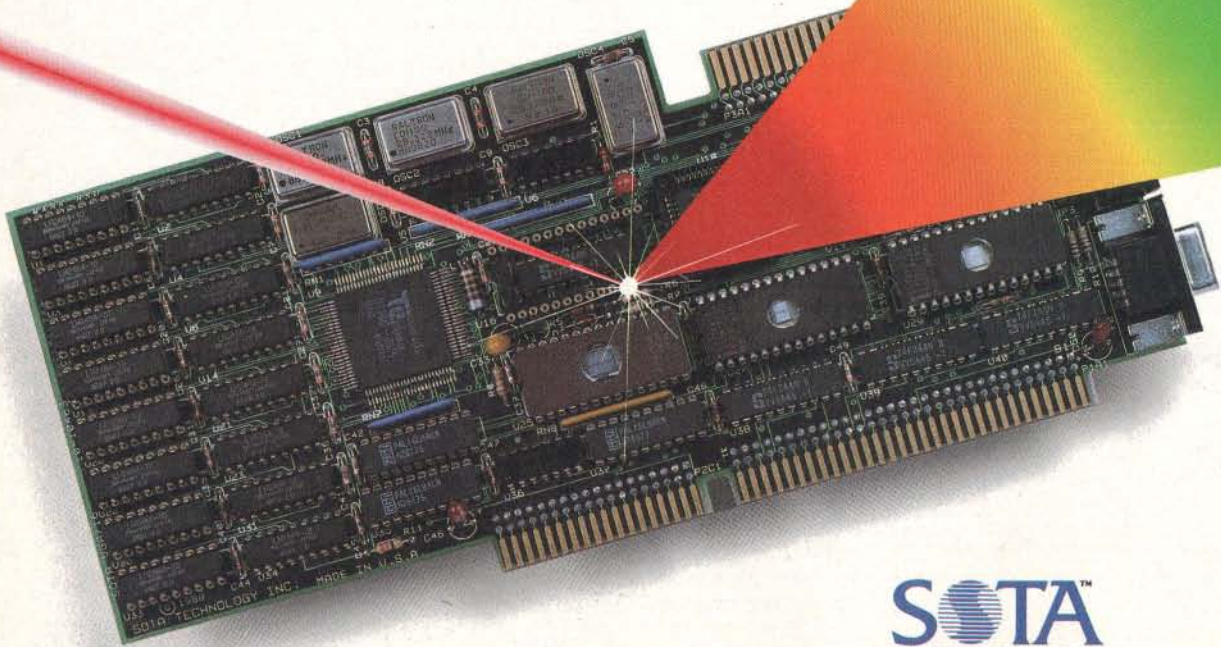

SOTA[™]
STATE OF THE ART TECHNOLOGY[™]

SOTA Technology, Inc.

559 Weddell Drive
Sunnyvale, CA 94089

SOTAVGA/16 is a trademark of SOTA Technology.
All other products mentioned are trademarks of their respective manufacturers.

She also doesn't realize Hewlett-Packard makes PCs.

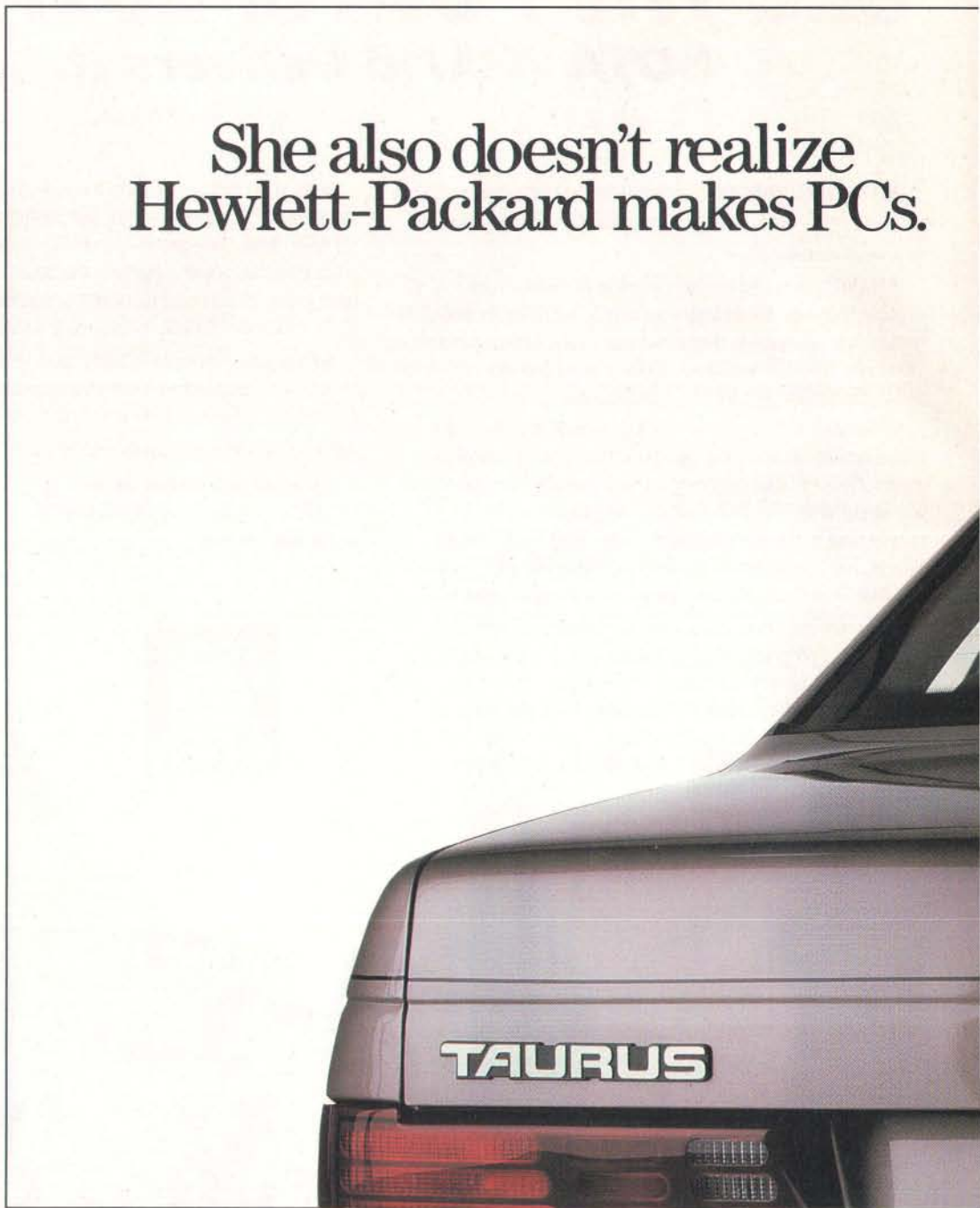

What a loss. Because Hewlett-Packard has a line of eight high-performance personal computers. PCs which range from desktop and floor-mount Intel386™-based powerhouses to entry-level 8086-compatibles. PCs which offer you a better way of doing business.

Hewlett-Packard personal computers give you plenty of opportunity for expansion. As well as plenty of options.



The HP Vectra QS/20 PC. One in a line of eight PCs from Hewlett-Packard.

386 is a trademark of Intel Corporation
©1989 Hewlett-Packard Company CP-PC904



At the high end, you can get up to 8 accessory slots, 620 Mbytes of hard disk storage, and 16 Mbytes of RAM. And on all models, you get a choice of video solutions and the flexibility of using either 5.25" or 3.5" disks.

Beyond this, an investment in Hewlett-Packard PCs allows you to choose confidently from thousands of software applications and peripherals. HP's strict

adherence to industry standards insures compatibility. Now, and into the future.

But the most important feature, the one you won't get with any other personal computer, is Hewlett-Packard reliability. For 50 years, HP has promised, and delivered, exceptional quality in everything from calculators to HP LaserJet printers.

Finally, every PC made by

Hewlett-Packard is backed by an extensive network of trained, authorized dealers. For more information and the name of your nearest dealer, call **1-800-752-0900**. You'll soon realize what an HP personal computer can do for you.

There is a better way.



NANOBYTES

"Standards do not limit; they liberate creative application of technology." Allen joined the industry's Greek chorus chanting for standardization in a world where users want to mix products from different vendors. Are the chorus members listening to each other?

At Microsoft's annual CD-ROM conference recently, **Michael Schulhof**, vice chairman of Sony Corp. of America, chided the CD-ROM industry for not yet settling on standards. "This industry has emerged from obscurity to confusion," Schulhof noted. "It is time to make ANSI standards official rather than advisory."

Raster Image Processing Systems (Boulder, CO) said it has cracked the encryption scheme used by **Adobe's PostScript** type fonts, which could enable people to use

continued

In the lower-resolution modes (16 bits or less), 32-Bit QuickDraw uses dithering (the approximation of adjacent colors) to convert the high-resolution color data to the lower-resolution mode. If the monitor is black-and-white, the converted image will appear in gray scale, with the number of gray-scale levels depending on the resolution of the video board (an 8-bit gray-scale board can display 256 levels of gray).

But color is not cheap. To have all these hues, you'll need a third-party video board and monitor. Radius introduced a series of color video boards that support 1152 by 882 pixels and feature a 72-Hz screen-refresh rate and up to 3 megabytes of video RAM. Radius is offering a 16-bit version, the DirectColor/16, for \$3695; and a 24-bit version, the DirectColor/24, for \$4995. Radius also has a 19-inch color display for \$4295. SuperMac's Spectrum/24 board sells for \$3999; current owners of SuperMac color boards can trade up to the Spectrum/24 for \$2499. RasterOps is selling its ColorBoard 224 for \$5195; owners

of the ColorBoard 104 can trade up for \$3000.

RasterOps has for some time been offering 24-bit video boards that use a color model that's incompatible with 32-Bit QuickDraw. Instead of the chunky color model used by 32-Bit QuickDraw, RasterOps offered boards that used a chunky planar color model, in which the bits defining the pixel are stored in separate chunks (32-bit words) for each color (red, green, and blue). Rather than displaying the pixel with a single memory access to a single 32-bit word, as in the chunky model, the chunky planar model requires three memory accesses to three separate 32-bit words, one for each color. Developers who have written software for RasterOps's chunky planar will have to rewrite their programs to support 32-Bit QuickDraw. RasterOps insists that it will support all current customers and let them upgrade to boards and software patches that support 32-Bit QuickDraw.

Because it involves very complex

continued

This Should Go On Your Desk For The Same Reasons It Goes On The Road.

Remember when sending a fax meant leaving your desk? Or when faxing on the road was almost impossible?

Those days are over. Introducing the WorldPort 2496™ portable fax and data modem.

Since it's external to your computer, it's easily shared around the office. And since it's battery powered and uses RJ11s or optional acoustic couplers, it connects to public phones and PBXs anywhere. Via Bell and CCITT standards worldwide. It even sends and receives fax and

data messages unattended or while you run applications.

But best of all, from your desktop or laptop, you can instantly connect with practically anyone anywhere who owns a fax or modem.

Unless, of course, they've ventured out on the road without one.

Call us today at 800-541-0345 (in New York, 516-261-0423) for more on the WorldPort line and the dealer nearest you.



Touchbase Systems, Inc.
160 Laurel Avenue
Northport, NY 11768
(516) 261-0423
Fax (516) 754-3491

WorldPort 2496 is a trademark of Touchbase Systems, Inc. © 1989 Touchbase Systems, Inc.

Introducing Close-Up/LAN the remote that lets you control all PCs on your network

Close-Up/LAN brings you a level of control never before possible. It connects PCs on your network giving you the versatility to instantly share screens and keyboards. With one PC, or simultaneously with all PCs up and down your network. Close-Up/LAN lets people work together.

Helping people

You're sitting at your PC on the 3rd floor working on a spreadsheet budget. Suddenly, a message appears on your screen: "Bob requests help". You press a hot key, and like magic you are looking at Bob's screen. Without moving an inch you see that Bob is working on the company database. A dialog window appears and Bob explains his problem. Since your keyboard is active you instantly solve the problem, on Bob's computer.

With another hot key you decide to look in on Sue's computer screen. She's new and you need to keep an eye on her work. You see that she is working on a letter using a word-processor. You monitor her for awhile without interfering with her work. In fact, Sue doesn't even know you're there!

Hot key again and off you go on your rounds of the company. Viewing one screen after another, helping some, watching others. All from the comfort of your chair. Finished, you hot key back to your spreadsheet and carry on with your budget. Amazed, you think that support has never been this easy before.

Workgroup Conferencing

As a workgroup problem solving tool, Close-Up/LAN is unsurpassed! Close-Up/LAN lets everyone in your workgroup work as a team. Your associates can chat in a conference, all linked together on screen, no matter how distant the locations. Bring up a spreadsheet, for example, and show your sales projections for all to see. With live keyboards and an instant screen

to screen connection, associates can adjust your figures (optionally at your discretion) for what-if scenarios.

On-Network Meetings?
Close-Up/LAN lets you conference your people over a single network, over bridged networks, or between networks thousands of miles apart.

Only one program lets you have your meetings on your network, Close-Up/LAN.

Distributed Processing

Close-Up/LAN distributes valuable LAN resources to all PCs on your network.

No matter where your PC is located you can access resources such as high speed processors (386's), CD ROM's, plotters, Irma type connections to mainframes, and modem equipped PCs that are connected to your LAN.

It's simple to think of ways to save money with Close-Up/LAN. Attach an inexpensive PC with a modem to your network. Instantly you have a shared communications server. Everyone on the LAN has access to that PC and modem, to run communication programs, terminal emulators, etc. Saving on modem and phone line costs.

Access is only a keystroke away. While working at your word processor, you decide to run a CPU intensive job on a 386 computer located somewhere on your network. Hot key to the 386 and control it as if it were your own. Close-Up/LAN connects your keyboard and screen to the 386. Start your CPU intensive job (like re-indexing a database). Then, hot key back to your wordprocessor. Toggle back, and you can view the 386.

Think of it. You can give everyone on your network the power of all peripherals at a fraction of the cost.

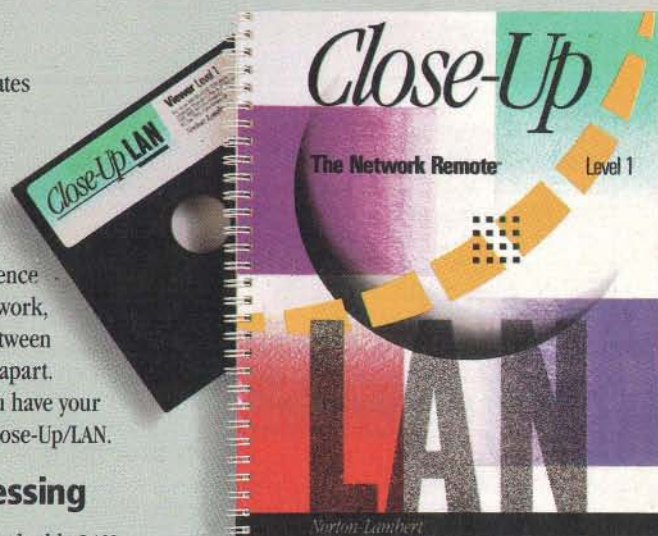

Training & Teaching

Close-Up/LAN lets your students watch on their PCs while you solve problems on your PC. Ideal for corporate and university classrooms. You can then reverse the process. Students work at their own pace while you, at the touch of a key, hop from screen to screen, monitoring their work.

There is only one program that fulfills the promise of your LAN's connectivity. Bringing people and PCs together . . . Close-Up/LAN.

Close-Up LAN

Call: 805/964-6767

Norton-Lambert
P.O. Box 4085, Santa Barbara, CA 93140 USA
Telex 709170

NANOBYTES

Adobe fonts on printers lacking Adobe-licensed controllers. RIPS, which makes high-speed laser printer controllers, cracked both the character descriptions and "hints," which basically handle how a character should stretch or scrunch and still remain aesthetically appealing as its point size changes. An Adobe-licensed laser printer knows how to interpret Adobe fonts, but now RIPS controllers should be able to do that. RIPS expects to integrate its decoding technology into its controllers. How did RIPS crack the code? "We took a logic analyzer, hung it on a 68000 bus, and observed," said chief technologist Ray McCaslin. With that puzzle solved, RIPS controllers should be able to handle any Adobe font, he said.

Here's one you won't find at your
continued

memory management, particularly in its dithering or transfer modes to lower resolutions, 32-Bit QuickDraw is noticeably slower than 8-bit Color QuickDraw. One manufacturer, E-Machines, has decided to build a graphics accelerator into its 24-bit video boards and will not announce its products until this summer.

The new QuickDraw launches the Mac into the high-end full-color market, but with a high price tag and questions about the system's perfor-

mance. A 24-bit video board and full-color display add at least \$7000 to a Macintosh system, putting it in the same price range as full-color setups from Silicon Graphics or Sun Microsystems.

Apple believes that it can compete with companies like SG and Sun because it is a "general-purpose" machine rather than a specialized workstation, according to Laurie Girard, Apple's product manager for Macintosh system software.

PCs with CDs: Multimedia Machine of the Masses? Microcomputer Moguls Think So

The computer of the future will be a multimedia device—a machine that plays stereophonic sound and shows full-motion video with a clarity rivaling TV. All this will cost less than today's conventional personal computer, and, just like TV, there will eventually be one in nearly every household in America. That's the scenario being promoted by Microsoft,

IBM, Sony, Intel, and Philips.

At the recent Microsoft-sponsored Fourth International Conference on CD-ROM, those companies all pledged to support this multimedia concept and to develop the technology necessary to make it real. Intel and IBM will jointly fund a development center to promote Intel's DVI (Digital

continued

Your job is *computing* . . . Why does your keyboard emulate a typewriter?

Your PC keys have typewriter legends, not the specific commands you need! **Solution:** Hooleon's SnapCap KeyCaps™ or non-slip adhesive Keytop Label kits, imprinted with the software commands! **Cut training costs** with Word Perfect 5.0™ or 5251 Emulation KeyCaps for the IBM® 101-Key Keyboard. **Customize your keyboard** with relegendable keys for IBM®, Cherry™, Wyse™ and Key Tronic™. Choose from

non-slip Keytop Labels supporting Word Perfect™, DisplayWrite™, Multi-Mate Advantage™, Microsoft Word™, Data Entry, Language Conversions and more. **We Custom Imprint Keys and Labels to your specs!**

Call for your **FREE CATALOG!**

To order call:

602 634-7515 or FAX: 602 634-4620

From the Leader in Keytop Innovations . . .

Hooleon
CORPORATION

P.O. Box 201, Dept. BYTE,
Cornville, AZ 86325



Leader of the Mac!



The Experts Agree:

FoxBASE + /Mac's New Version 1.10 is the Ultimate Relational Database Management System for the Macintosh!

Don Crabb, *InfoWorld*, July 11, 1988:

"FoxBASE+/Mac proved to be as easy to use as any Mac relational database we've tested."

Macworld, September, 1988:

"FoxBASE+/Mac deserves serious consideration as both a stand-alone database product and a connectivity solution."

Richard Skrinde, *MacUser*, September, 1988:

"FoxBASE+/Mac is a racehorse that will outrun the other Macintosh databases."

Arthur Fuller, *Computing Canada*, June 9, 1988:

"So phenomenally great that it justifies the purchase of a Macintosh just to run it!"

Michael Masterson, *MacWEEK*, June 7, 1988:

"FoxBASE+/Mac proves beyond a doubt that the Mac is a suitable platform for supporting fast database operations."

BYTE, September, 1988:

"FoxBASE+/Mac combines dBASE compatibility with a strong list of features and a work environment with which Mac users will feel comfortable."

Charles Seiter, *Macworld*, October, 1988:

"It's the fastest general purpose Mac database, often ten to a hundred times faster than its competitors."

FoxBASE+/Mac Version 1.10 includes everything you love about the original FoxBASE+/Mac PLUS a new form generator, an outstanding application generator and a complete template language system—all designed to save you time and effort! Now you can develop complete database applications in just minutes!

And now Fox Software introduces FoxBASE+/Mac Multi-User, leading the industry with the ultimate in data sharing — *concurrent data access!* For the first time, networked Macs and PCs can simultaneously share the same data files!* In addition, FoxBASE+/Mac Multi-User supports an unlimited number of users on your network.

Even with all these enhancements, Version 1.10 doesn't cost any more — it's still only \$395! And our new Multi-User is just \$595!

FoxBASE+/Mac earned an exceptional 7.0 rating on *InfoWorld's* Software Review, and a 4.5 rating on *MacUser's* scale. It's the one Mac database system that has it all!

Join the experts NOW! Contact your local quality software dealer, or order your copy of FoxBASE+/Mac by calling (419) 874-0162, Ext. 320. Free demo package available.

Why be a follower when you can go with the *leader!*

Fox Software

Nothing Runs Like a Fox.

Fox Software
118 W. South Boundary
Perrysburg, OH 43551

(419) 874-0162, Ext. 320.
FAX: (419) 874-8678
TELEX: 6503040827 FOX

* Requires a copy of FoxBASE+/LAN, our PC multi-user software, on the network file server. FoxBASE+/Mac and FoxBASE+/Mac Multi-User are trademarks of Fox Software. dBASE is a trademark of Ashton-Tate. Macintosh is a trademark of Apple Computer, Inc.

NANOBYTES

neighborhood video store: "What Neural Nets Can Do" is an 80-minute videotape (VHS) intended for people who need to judge the actual practical potential of neural net technology, according to the company offering the tape (Lawrence Erlbaum Associates, Hillsdale, NJ). This video tutorial stars **James Anderson**, professor of cognitive and linguistic sciences at Brown University and coeditor of *Parallel Models of Associative Memory*. The tape and accompanying 144-page manual cost \$250; a demonstration tape costs \$10.

The Fortran Journal is a new publication offering programming hints, short news items, and product reviews. The journal comes out six times a year. The cost for a one-year subscription is \$28 in the U.S. and \$36 everywhere else. Contact the **Fortran Users Group**, P.O. Box 4201, Fullerton, CA 92634.

As part of a venture with Hitachi, **VLSI Technology** (San Jose, CA) has developed a 256K-bit static RAM chip with an access time of 35 ns, VLSI says.

As part of their new working relationship, **Sun Microsystems** (Mountain View, CA) and **Cray Research** (Minneapolis) are offering a channel interface that connects Sun workstations with Cray supercomputers. The FEI-3 adapter consists of two VME boards that slip into a Sun-3 or Sun-4 and connect with 100-megabit Cray channels. Sun has written drivers for process-to-process communication and remote log-in.

Apples and Oranges: **AST Research** (Irvine, CA) has sold off its line of Apple products to Orange Micro (Anaheim, CA). AST's products for the Mac include Mac86 and Mac286, coprocessor boards designed to allow the machine to run IBM PC software.

And from the Department of It Loses Something in the Translation: After-booting-up message seen recently on a foreign laptop: "Now had loaded lat-top utilities."

Video Interactive) technology, designed to compress 70 minutes of high-quality video into a form that can be stored on a CD-ROM disk and viewed on a personal computer. Microsoft, Sony, and Philips released their CD-ROM XA specifications in an effort to set a standard for how audio is handled in future CD-ROM-based products. XA disks will be able to hold 8 hours of stereophonic sound (or 16 hours of mono).

To make computers exciting to consumers who could care less about spreadsheets and word processors, it will take a flashy video interface and high-quality audio, said Microsoft chairman Bill Gates. All that and a low price will make a personal computer a consumer item rather than a specialized set of hardware.

"While a poison index and the Bible on CD are nice things to have," Gates said, "they are not the types of things that will sell to the general public."

By 1990 or 1991, Gates said, the

magical computing machine for the masses will be a 1-megabyte system with Windows, XA sound, extended VGA resolution featuring overlaid text with high-quality pictures, and the start of interactive tools. After that, this multimedia machine will be running OS/2 Presentation Manager, will have 4 megabytes of RAM, be able to play stereo sound, and have the DVI chip providing capabilities to display full-motion video.

"IBM shares the excitement of multimedia," said IBM Entry Systems president James Cannavino. "This will reshape how people envision personal computers." Cannavino pledged IBM's support to DVI, CD-ROM, and multimedia. IBM and Intel aim to have a single Micro Channel board that can handle high-quality video and sound by 1991. Intel announced at the conference a system for developing DVI applications. The \$21,500 Pro 750 is built around an 80386-based AT with seven DVI-related boards.

Agnus Gives Amiga Graphics Better Memory

With the release of the new Agnus chip for the Amiga—the custom chip that handles graphics operations—Commodore Business Machines removed one of the major graphics bottlenecks in that computer. The new chip, a plug-in replacement for existing Agnus chips in all Amigas except the original model A-1000, lets programs use up to 1 megabyte of memory for graphics. The megabyte of display memory will give developers more headroom, allowing higher-resolution images and generally improved graphics on the Amiga.

The chip is available through Commodore service centers, said Amiga product manager Keith Masavage. He said the cost of the chip will be between \$100 and \$150.

The new chip fixes a peculiarity of the Amiga architecture that has been cramping some users and applications programmers. Although the machine can be filled with as much as 8

megabytes of memory, the Agnus chip could address only 512K bytes. That meant that only 512K bytes could be used for display purposes. Masavage said that a typical high-resolution screen on the Amiga could use as much as 150K bytes. Animation often requires holding more than one screen in memory at a time, and since some of the 512K bytes (called "chip memory" in the Amiga world) has to be used for direct-memory-access channels, it was possible for an Amiga to run out of graphics memory even though most of its total memory was unused. Some developers with both Amiga and Macintosh versions of their products have taken to using Mac IIs to get high-quality displays of their images.

Despite the memory situation, the Amiga has established itself in the world of professional video and animation, where it competes with systems costing 10 times as much.

NEWS STAFF SEEKS NEWS. DIAL (603) 924-9281.

The BYTE news staff is always interested in hearing about new developments that might affect microcomputers, the way they work, or the way people work with them. If you know of a project that could shape the state of the art, please give us a call at (603) 924-9281 or write to us at One Phoenix Mill Lane, Peterborough, NH 03458. An electronic version of Microbytes, offering a wider variety of computer-related news on a daily basis, is available on BIX.

A complete compendium of the latest tools, techniques, and ideas ...

Take The 3-Volume OPERATING SYSTEMS SET For Only

\$4.95

A
\$113.95
Value

as your introduction to the
Library of Computer and Information Sciences

You simply agree to buy 3 more books—at handsome discounts—within the next 12 months.

OPERATING SYSTEMS

Design and Implementation

Andrew Tanenbaum

"Probably the best book on the subject"

—Eastgate Systems

This 800-page introduction to operating system design and implementation is packed with practical descriptions of principles and techniques, as well as a complete implementation of a UNIX-like operating system and 300 pages of source code. Filled with examples from such commercial operating systems as UNIX, MS-DOS, CP/M, and MULTICS, it explains processes, input/output, memory management, file systems, and much more.

Publisher's price: \$46.00

INSIDE OS/2

Gordon Letwin

"During the next 10 years, millions of programmers and users will utilize OS/2... The best way for them to understand the overall philosophy will be to read this book."—Bill Gates

This programmer-to-programmer's guide helps you maximize the power, performance, and potential of OS/2. Microsoft's chief systems architect Gordon Letwin walks you through the nuts-and-bolts of this breakthrough technology covering everything from memory management, environment strings, and signals to interprocess communications and device monitors.

Publisher's price: \$19.95

OPERATING SYSTEMS DESIGN

The XINU Approach

Douglas Comer

Eliminate the confusing elements of UNIX with XINU, a more versatile, level-structured operating system. This step-by-step guide covers all aspects of XINU beginning with the basics.

You'll understand the design and implementation parameters of memory and process management, process coordination and synchronization, real time management, device drivers, and inter-machine communication.

Publisher's price: \$48.00

MEMBERSHIP BENEFITS • In addition to getting The Operating Systems Set for only \$4.95 when you join, you keep saving substantially on the books you buy. • Also, you will immediately become eligible to participate in our Bonus Book Plan, with savings of 65% off the publishers' prices. • At 3-4 week intervals (16 times per year), you will receive the Library of Computer and Information Sciences News, describing the coming Main Selection and Alternate Selections, together with a dated reply card. • If you want the Main Selection, do nothing, and it will be sent to you automatically. • If you prefer another selection, or no book at all, simply indicate your choice on the card and return it by the date specified. • You will have at least 10 days to decide. If, because of late mail delivery of the News, you should receive a book you do not want, we guarantee return postage.

The Library of Computer and Information Sciences is the oldest, largest book club especially designed for computer professionals. In the incredibly fast-moving world of data processing, where up-to-the-moment knowledge is essential, we make it easy to keep totally informed on all areas of the information sciences. What's more, our selections offer you discounts of up to 30% or more off publishers' prices.

If reply card is missing, please write to the Library of Computer and Information Sciences, Dept. 7-FG2-00920, Riverside, NJ 08075, for membership information and an application.

Byte 6/89

© 1989 Macmillan Book Clubs Inc.

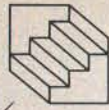

Everex, Step and AAAA are trademarks of Everex Systems, Inc. All other product names are registered trademarks of their manufacturers.





**"If this is a race, we
are out in front."**

Steve Hui, President
Everex Systems, Inc.

IBM PS/2 Model 80 (20 MHz)	3.52 MIPS
Compaq DeskPro 386/20	4.59 MIPS
Everex Step 386/20	4.91 MIPS

Power Meter MIPS Version 1.2. The Database Group.

"We created a
monster."

Apparently, we
have surprised a
few people. It's not
every day that
someone builds
the world's fastest
386/20.

Our marketing
people call the con-
cept AMMA – for
Advanced Mem-
ory Management
Architecture.

I don't care what
you call it. This is
the computer that
has left everybody
behind, including
Compaq.

For the moment, we
are overjoyed.
But this is a game
of leapfrog and
we do not intend
to rest.

The Step 386/20
from Everex
is a monster of
a machine.

For price and
performance facts,
call Everex
Computer Systems
Division at 1-800-
356-4283. Everex,
48431 Milmont
Drive, Fremont,
CA 94538.



Still
trying to get
Engineering
& Scientific
graphs
from a
Business
program?

TECH* GRAPH* PAD

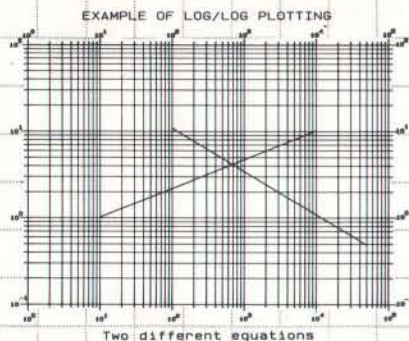

Easy-to-use technical graphing & plotting software for engineers & scientists. Compatible with Lotus 1-2-3 worksheets, other spreadsheets, PRN & ASCII files, & most data acquisition packages.

Now shipping Version 3.0!

- X-Y, Semi-log, Log/Log, Polar Plots
- Curve Fitting • Data Smoothing
- Labels, Scale, & Color Control
- Multiple X-Y Axes
- Error Bars • Greek Letters
- Laser Printer, Plotter, Printer Output
- IBM PC/XT/AT, PS/2, Apollo, DEC compatible

CALL

(617) 290-5900

Dealer Inquiries Invited

 **binary engineering**

400 Fifth Ave., Waltham, MA 02154

LETTERS

and Ask BYTE

Shareware Isn't Freeware

Shareware is not public domain software! The author of a public domain program releases all legal rights to the product; the author of a shareware program does not. Shareware authors usually encourage users to register so that authors can provide technical assistance, make enhancements, and so on. When users are aware of the difference between shareware and public domain software, it helps shareware authors to provide this service to their registered users.

Marshall W. Magee
Norcross, GA

Executing Operations

"Worth the RISC" by Trevor Marshall and Jane Morrill Tazelaar (February) was a very good survey about where RISC is today.

In the section headed "What Is RISC?" the article states that most RISC instructions execute in one cycle: "The RISC chips, however, execute most of their instructions in one cycle and make further performance gains with a technique called *pipelining*, which uses multiple execution units."

If by "execute" the authors mean to process an instruction from instruction fetch to instruction completion, then a typical instruction takes four cycles: instruction fetch, decode instruction and fetch registers, execute operation, and write back registers.

However, the "execute operation" part of the pipeline takes one cycle. Since each stage of the pipeline is simultaneously processing a different instruc-

tion, an average of one instruction is finished per cycle. Therefore, instructions are processed at a rate of one instruction per cycle.

If by "execute" the authors mean the "execute operation" part of the pipeline, then only one instruction is being executed at a time. This distinction is important because future chips may have multiple sets of pipelines. These chips will be able to process at a rate of more than one instruction per cycle.

Les Faby
Cupertino, CA

X Windows vs. Display PostScript

"The X Window System" by Dick Pountain (January) was most informative. But the article also contained some misleading information that needs clarification.

Pountain made a few comments regarding the competition between X Windows and the Display PostScript system. For instance, he says that X Windows' main competition is Display PostScript, which offers more powerful typographic functions—although the two systems are not exclusive and might even complement each other. He also describes Display PostScript as "a possible video graphics standard in apparent competition with X Windows."

Display PostScript is not in competition with X Windows. Rather, Display PostScript is an imaging model that can be incorporated into X Windows or any other windowing system. In fact, Digital Equipment Corp. is doing exactly that with its recently announced DECstation 3100 workstation.

In this case, the Display PostScript system is an extension to the X server. To use it, an application goes through the X server. The application program can then use Display PostScript as the imaging model instead of calling on the graphics portion of the Xlib library.

Another point in Pountain's article that needs clarification is the following: "Sun, whose NeWS windowing system is based on Display PostScript..." Sun wrote NeWS, which is both an imaging

continued

WE WANT TO HEAR FROM YOU. Please double-space your letter on one side of the page and include your name and address. We can print listings and tables along with a letter if they are short and legible. Address correspondence to Letters Editor, BYTE, One Phoenix Mill Lane, Peterborough, NH 03458.

Because of space limitations, we reserve the right to edit letters. Generally, it takes four months from the time we receive a letter until we publish it.

PC EXPERTS AGREE:

Proteus® offers the fastest for the least, and supports them the most.



Proteus® sells the fastest personal computers you'll find. But as experts from BYTE, InfoWorld, Personal Computing, and others have discovered, our computers are more than just fast.

"You get... fifteen months of service coverage— and onsite at that. Even without the warranty, we highly recommend this machine."

Computer Buyers Guide

"The Proteus is an excellent value for the performance it offers potential buyers. Its speed, expansion capability, and service contract put it in a class with the big boys."

Personal Computing Magazine

"A remarkable range of performance and operational capabilities."

Ed McNierney, BYTE Magazine

For custom configurations and new low prices, call Proteus Toll-Free.

"This IBM-compatible is so fast I have had trouble measuring its speed."

Business Computer Digest

"Proteus is markedly faster than any other personal computer we've worked with, including Deskpro 386/20."

Personal Computing Magazine

"The Proteus is one of the fastest desktop computer systems we tested, a zero-wait-state hot rod."

InfoWorld Magazine

"...a complete multi-user solution that arrives with all peripherals and operating systems installed and tested... a very powerful machine that does what it claims."

Computer Shopper Magazine

PROTEUS 286-16

16MHz, ZERO WAIT STATE

- 80386 CPU running at 16MHz
- 640K RAM
- 8 expansion slots
- 5 drive bays
- 2 serial & 1 parallel port
- 1:1 interleave
- Hard disk & floppy controller
- 200W power supply
- 101-key enhanced keyboard
- 15-month on-site service free
- Made in U.S.A. **\$1,495**
- 30-day money back guarantee

COMPLETE SYSTEMS:

- Monochrome System \$1,656
- EGA Color Plus System \$2,112
- VGA 16-bit 800x600 System \$2,407

PROTEUS 386-20

20MHz, ZERO WAIT STATE

- Intel 80386 CPU at 20MHz
- 1MB RAM—Expandable to 16MB
- Intel 82385 EE cache ctrl
- 32K fast cache
- 2 serial & 1 parallel port
- 1.2MB floppy drive
- Dual HD & floppy controller
- 1:1 interleave
- 200W power supply, 110/220V
- 101 key tactile keyboard
- 15-month free on-site service
- Made in U.S.A. **\$2,595**
- 30-day money back guarantee

COMPLETE SYSTEMS:

- Monochrome System \$2,839
- EGA Color Plus System \$3,295
- VGA 16-bit 800x600 System \$3,595

PROTEUS 386-25

25MHz, ZERO WAIT STATE

- Intel 80386 CPU at 25MHz
- 1MB RAM expandable to 16MB
- Intel 82385EE cache ctrl
- 32K fast cache
- 387 coprocessor support
- 2 serial & 1 parallel port
- Dual HD & floppy controller
- 1:1 interleave
- 200W power supply, 110/220V
- 1.2MB floppy drive
- 15-month free on-site service
- Made in U.S.A. **\$3,495**
- 30-day money back guarantee

COMPLETE SYSTEMS:

- Monochrome System \$3,695
- EGA Color Plus System \$4,070
- VGA 16-bit 800x600 Multiscan System \$4,595

PROTEUS SYSTEM 3400ME UNIX & DOS MULTIUSER SYSTEM

- 80386-25 CPU, 25 MHz opt. 33 MHz
 - 8-User system support
 - 4MB 32-bit RAM
 - Intel 82385 ctrl
 - Cache Memory
 - 150MB ESDI fast hard disk
 - 1.2MB 5.25" or 3.5" 1.44MB fd
 - Upright server Case
 - 250W 110/220v power supply
 - SCO XENIX/PC MOS operating sys.
 - High res. 14" console/monitor
 - Graphics controller
 - Parallel & serial ports
 - 15-month free on-site service
- COMPLETE SYSTEM: \$8,795**
- Choice of optional terminals & Proteus Lightwave graphics term.



Circle 217 on Reader Service Card

To order, call us direct. 1-800-782-8387

In N.J. call 201-614-7000

For 24 hr catalog, call 1-800-548-5036 using your modem set at 1200B or 2400B/N/8/1.

Technical Support Hotline: 1-800-541-8933 Reseller/VAR programs available.

Custom configurations available.

trademarks recognized. © Proteus is a registered trademark of Proteus Technology Corp. All prices, terms, specs subject to change.

proteus
THE INTELLIGENT CONCLUSION
75 Kingsland Ave.,
Clifton, N.J. 07014

Some Things Never Change

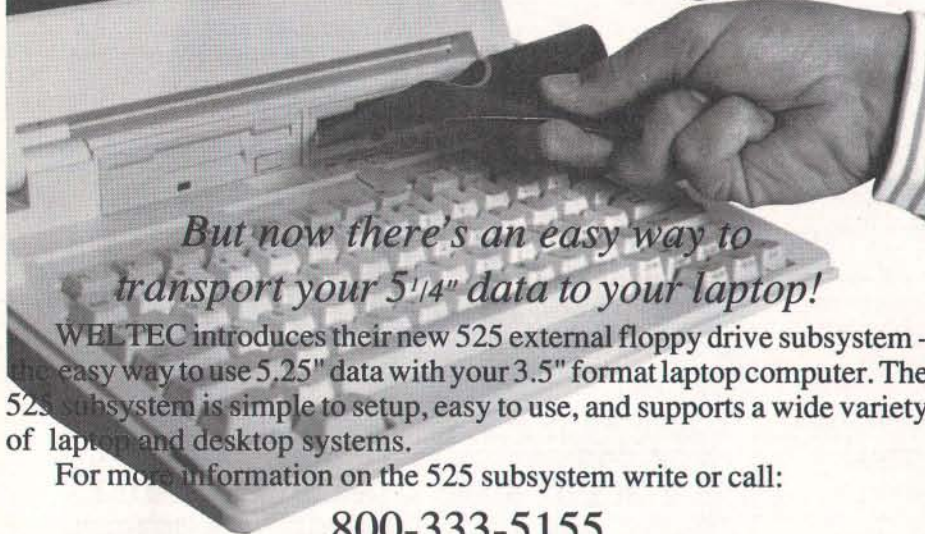

But now there's an easy way to transport your 5 1/4" data to your laptop!

WELTEC introduces their new 525 external floppy drive subsystem - the easy way to use 5.25" data with your 3.5" format laptop computer. The 525 subsystem is simple to setup, easy to use, and supports a wide variety of laptop and desktop systems.

For more information on the 525 subsystem write or call:

800-333-5155



WELTEC digital, inc.

17981 Sky Park Circle, Suite M, Irvine, CA 92714
Phone: 714-250-1959 • Telex: 3728057 • FAX: 714-250-1964

LETTERS

model and a windowing system, using the PostScript language. However, Sun is not a licensee of the Display PostScript system, nor is NeWS based on the Display PostScript system. Rather, Sun created its product independently of Display PostScript. Sun developed its own extension to the PostScript language for interactive displays and color, and these extensions are not the same as Adobe's extensions.

Pat Marriot
Director of Marketing
Adobe Systems, Inc.
Mountain View, CA

NeXT Performance

Your cover story on the NeXT computer (November 1988) expressed skepticism about the performance of Display PostScript. Having ported FrameMaker, our publishing software, to the NeXT machine, we can report that we're very pleased with the performance of Display PostScript (and the whole NextStep environment, for that matter).

David J. Murray
Frame Technology Corp.
San Jose, CA

API Clarification

I'm glad there's a magazine that provides at least some degree of technical information about OS/2, rather than the now-tiresome debate regarding its chances for success. I am referring to Mark Minasi's OS/2 Notebook column.

As a software engineer trying to write an application for OS/2, I appreciate the availability of a source of information other than Microsoft's overwhelming and unclear pile of manuals. However, in "1988 in Review: OS/2's First Year" (January), the code fragment Minasi gives as an example of an Application Program Interface function call is erroneous and misleading. It should appear as follows:

```
ret_code = DosGetPid(&MyPID);
if ret_code
    printf("DosGetPid failed:
        %d\n",ret_code);
else
    printf("Process ID=%d\n",
        MyPID.pid);
```

There are two differences between my fragment and his. First, he was printing the error message when the call was successful, and the process ID when it failed. In the paragraph following the fragment, he stated its intent correctly—he simply had it coded incorrectly. Sec-

continued

FREE INFO KITS FOR DEVELOPERS!

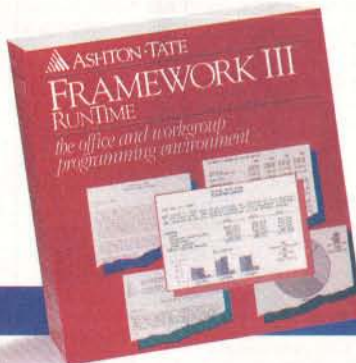

NEW! Build better applications faster and more economically with **Framework III™ RunTime**—the first integrated PC software development engine with built-in multiple functions and a royalty-free licensing agreement.

SPECIAL ADVANCE NOTICE! Get more programming power, flexibility and control over integrated microcomputer applications development with the **Framework III Developer's ToolKit**.

CALL TOLL-FREE 1-800-437-4392, EXT. 1801

GET YOURS NOW!

New Report:
Framework III RunTime
Info Kit. Available Now!

Fast-breaking news:
Framework III Developer's
ToolKit Information.
Available Soon!

Tell us what you do:
 Developer VAR
 Corporate/MIS Manager
 Other

YES, ASHTON-TATE! I want to find out how I can save time, save money and enhance my software applications! Send me the FREE software information I've checked!

NAME (PLEASE PRINT) _____
TITLE _____
COMPANY NAME _____
CITY _____ STATE _____ ZIP _____

BUSINESS PHONE _____
Mail to Ashton-Tate, 14 Inverness Drive East, Building E, Suite 104, Englewood, CO 80112. Or for faster service, call us toll-free at 1-800-437-4392, ext. 1801.

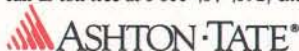

The Ashton-Tate logo and Ashton-Tate are registered trademarks of Ashton-Tate Corporation. Framework III is a trademark of Ashton-Tate Corporation. © 1989 Ashton-Tate Corporation. All rights reserved. Specifications and prices subject to change without notice.

Turn a task into child's play.

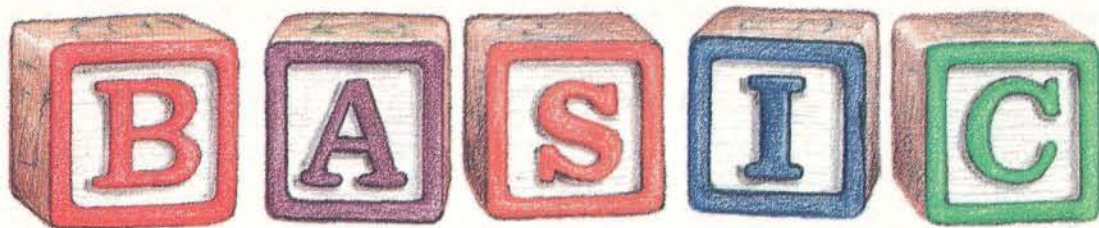

PROBAS™ Basic Programming Library

Announcing **PROBAS** Version 3.0, now with over 365 assembly routines to really kick QuickBASIC and BASCOM into high gear. **BYTE** magazine calls **PROBAS** a "Supercharger for QuickBASIC". Thousands of programmers rely on **PROBAS** to make their life easier and to enhance their programs with features like:

- A 1,000 page 2 volume manual
- Full-featured windowing
- Screen snapshots (Text & Graphics)
- String, array, and pointer sorts
- Lightning-fast file I/O
- Full mouse support

Create dazzling screens in text mode, CGA, EGA, VGA or Hercules graphic modes. Save and restore screen snapshots to arrays, EMS memory or files. Full featured windowing to meet the most demanding jobs. The **PROBAS** system of virtual screens allows you to draw full or partial screens to memory, and then snap them on in an eyeblink. You can even create virtual screens far larger than the display screen.

Sick of running out of string space? Store hundreds of K in numeric arrays or megabytes in extended or expanded memory. Tired of using a kludgy SHELL to DIR to read a directory or archive files? Scan sub-directories or .ARC files using wild-cards and store thousands of file names, dates, and times. Wish you could drag a window containing text or a menu around the screen with a mouse? It's easy!

PROBAS gives you a complete set of blazingly-fast file routines. Read or write huge chunks of data at a clip, with file locking and error handling so that you can even use them in subprograms. You'll never want to use BASIC's file I/O again! Sort data with lightning fast array and pointer sorts. Search files or arrays at assembly speeds. **PROBAS** also has over 200 other essential services including handy string, date, time, directory and array manipulation, string, screen and data compression, full mouse support, valuable equipment and input routines and faster replacements for most BASIC commands.

Whether you are a professional or a novice, **PROBAS** will boost your BASIC in ways you never dreamt possible. **PROBAS** allows professionals to save time and work and lets novices write professional-quality programs quickly and easily. After all, how much is a few hundred hours of your time really worth?

For all versions of QuickBASIC and BASCOM including BASCOM 6.0 for OS/2. **Just \$135.00!**

PROREF™ On-Line Help For PROBAS

PROREF provides pop-up help for the routines in **PROBAS** and is an extension of the QuickBASIC programming environment. Find help on any routine with a few keystrokes or mouse clicks. Pop-up an ASCII chart, calculator, scan code module, box diagram, your own help information or almost any DOS program via a hot-key. **Just \$50.00!**

PROSCREEN™ Screen Management

PROSCREEN is a full-featured screen generator/editor that will save you more design and coding time than you ever thought possible. **PROSCREEN** treats screens like a word processor treats text to provide complete control over characters, colors, and placement. Design input screens with up to 130 fields and 19 pre-defined and 2 user-defined masks. Use **PROBAS** or the included BASIC/Assembler subroutines to access the screens. No kludgy code generators here! Comes with subroutine source, extensive on-line help, and a 285 page manual. **Just \$99.00!**

PROMATH™ Mathematics Library

PROMATH is a collection of over 150 high-level routines that provide mathematical functions and operations for programmers who often work in mathematics, science, or engineering. Complex variables, real and complex matrices, real and complex trigonometric and hyperbolic functions and their inverses, solution of linear equations, integration, differential equations, Fast Fourier transforms, graphics support, and many other useful routines are provided.

For years Fortran has been the language of choice for scientific and engineering applications, but it lacks many of the useful features of QuickBASIC. **PROMATH** contains most of the Fortran mathematical and numeric functions and allows you to easily translate Fortran code to BASIC or write new programs in BASIC while retaining Fortran's numerical prowess.

The **PROMATH** manual is over 200 pages and provides a complete description of each routine, including any algorithm and the mathematical formula the routine uses, shown in standard notation. For QuickBASIC 4 and BASCOM 6 only. **Just \$99.00!**

PROBAS™ TOOLKIT

The **TOOLKIT** is a collection of assembly and BASIC modules that use the **PROBAS** library to save you even more hours of grunt work. Why spend hundreds of hours re-inventing the wheel when you can just plug in **TOOLKIT** modules like:

- Menu Generators
- Fast B-tree indexing
- Mini-editor with word-wrap
- Patch .EXE files
- Protected storage areas
- Julian date routines

The **TOOLKIT** also includes clock, calendar, windowing, BCD math routines and much more, complete with BASIC source code and a comprehensive manual. The **PROBAS TOOLKIT** adds capabilities and helps conserve your most valuable asset of all—time! Requires **PROBAS**. **Just \$99.00!**

PROBAS™ TELECOMM TOOLKIT

The **PROBAS TELECOMM TOOLKIT** is a collection of high-level communications modules that you plug into your code to provide popular file transfer protocols, terminal emulations, login scripts and baud rates up to 115,200 baud. You get:

- Xmodem/Modem7/Xmodem-1k
- Ymodem (single and batch)
- CRC-16 and Checksum
- VT52, VT100, ANSI BBS etc.
- Auto Dialer & data base
- Documented BASIC source

Why use clumsy SHELLs to complex terminal programs when you can plug just the communications routines you need into your code? Implement just the features and commands you want. Requires **PROBAS**. **Just \$75.00!**

Our thirty day, money-back guarantee assures you the highest quality and our technical support staff is always ready to help.

HAMMERLY
COMPUTER SERVICES, INC.

9309 JASMINE COURT • LAUREL, MD 20707

(800) 343-7484

INT'L. ORDERS: (301) 953-2191 FAX: (301) 725-8147
BBS: (301) 953-7738

Add \$5.00 per item (\$8.00 Canada) for shipping per order. Europe: \$39.00 for 1st item plus \$5.00 for each additional item. Visa, M/C, C.O.D. (US Only) checks and approved POs accepted. Trademarks **PROBAS**, **PROREF**, **PROSCREEN**, **PROMATH**: Hammerly Computer Services, Inc. QuickBASIC, BASCOM: Microsoft Corp.

ond, the variable MyPID is a structure, and his fragment was printing MyPID, which yields the first value of the structure. Fortunately, the first value in the structure happened to be the process ID, so the correct value is printed. This is somewhat misleading, though; had the structure been different, the printed value would have been incorrect.

These points may seem trivial, but working with OS/2 has been a struggle for me, and I think it's important that, on

the rare occasions when useful information is published for OS/2 programmers, it should be as accurate and complete as possible.

David P. Sours
Blaine, MN

I did mix up the two clauses—sorry. As to the use of the structure, you're right again. Before your letter, I had never looked it up; rather, I had used it just as Microsoft did in a sample program.

I'm glad you find the column useful. Since that particular column came out, another book chock-full of sample code has come out. Called Peter Norton's Inside OS/2 (Brady Computer Books, 1988), it discusses areas of OS/2 (not Presentation Manager, alas—just the kernel) and includes sample C code.

—Mark Minasi

Delivering the Mail

The global village in electronic messaging has already moved from fiction to fact. The world does not need to look toward the future for worldwide electronic messaging. A great deal has already been implemented, and more is under development.

Contrary to the unconnected world described in the "X.400 Grows Up" by Brock N. Meeks (December 1988), intersystem messaging between most major systems in the U.S. and worldwide is now commonplace because of DA Systems' DASnet Service. All users of ABA/net, INET, UNISON, TWICS, the GeoMail network of hosts (installed in the U.S. and throughout Europe), PeaceNet, and, soon, CONNECT's MacNET and GoverNET can communicate with anyone who uses one of several dozen E-mail systems and networks. Not to mention the fax and the post office.

I take issue with Meeks's statement that "To have any kind of global interconnected network, you need a directory of some sort." That has not been the case with mail delivered by the post office or via fax. Though it will be useful, a directory is not the sine qua non of interconnectivity. What would Benjamin Franklin have replied to the proposition that a mail delivery system requires a universal directory of street addresses? I leave the answer to you.

Where X.400 or proprietary connections turn out to be the appropriate way for a service or company to connect, the DASnet gateway to X.400 will be useful to connect these services to all the other DASnet-linked systems.

Anna B. Lange
DA Systems
Campbell, CA

Trees 'n Leaves

I believe there are errors in Rick Grehan's otherwise fine series on B-trees ("Trees 'n Keys," Parts 1, 2, and 3, January through March). Grehan states, "A key's in-order successor will always be on a leaf node. You might want to sketch a few B-trees to convince yourself of this." I entered the following five names into a

continued

OCULUS™ - 10

A real time video digitizer for the VGA adapter.





OCULUS™ - 10 lets you:

- Grab images of moving scenes into your computer
- From all standard cameras and VCR'S
- In either Monochrome or full, true colors
- With VGA resolution

Contrary to competing products which take several seconds to scan an image, **OCULUS™ - 10** grabs most images in 1/20th of a second or less. Our software updates them on your VGA board at a rate of up to 6 images per second. **OCULUS™ - 10** gives you full freedom for:

- Digitizing images of live subjects
- Framing
- Focussing
- Selecting scenes from video recordings

Images can be saved in formats compatible with most electronic publishing and graphics software packages.

OCULUS™ - 10! A half-size add-on board for IBM-compatible micro-computers: PC, XT, AT, 386, and PS/2 models 25 and 30. The price? An unbelievable

ACTUAL UN-RETOUCHED PHOTOGRAPHS OF IMAGES GRABBED BY OCULUS™ - 10



SUPPLIERS OF HIGH QUALITY IMAGE PROCESSING PRODUCTS SINCE 1983

\$695.

To order, fill out the coupon, or call us.

IN THE US: 800-361-4914
OTHER: (514) 333-1301
FAX: (514) 333-1388

CORECO INC.
8968 Trans-Canada Highway
Unit 112, Saint-Laurent, Quebec, Canada
H4T 1V8

Please rush me an **OCULUS™ - 10** board, with utility software and Coreco's 3 months warranty, for \$695 (US currency) plus \$15 for shipping.

NAME: _____

ADDRESS: _____

STREET CITY
STATE ZIP

PHONE: _____

VISA MASTER CARD EXP: _____

CARD #: _____

SIGNATURE: _____

Specifications

On-board memory: 128 Kb
A/D converter: flash, 6 bits

FRAME-GRABBING TIMES:

Monochrome:
320 x 200, 4 bits: 1/60 second
320 x 200, 6 bits: 1/20 second
640 x 480, 4 bits: 1/30 second

Color: 320 x 200: 1/20 second

Super VGA mode soon available.

IBM, IBM PC, XT, AT, PS/2 are trademarks of International Business Machines Corporation.

DEALER INQUIRIES WELCOME.

GE Information Services GEnie™

A summary of your monthly charges:

Description	Time	Cost
Download 3 Files	1:00	6.00
Read messages on 2 bulletin boards	0:15	1.50
Check 10 stock quotes	0:05	.92
Read today's news	0:10	1.00
Play Stellar Emperor	0:30	3.00
Total hrs. non-prime/ 1200 baud	2:00	

Total Cost . . . \$12.42

CompuServe® Monthly Summary

A summary of your monthly charges:

Item	Hours	Cost
-Download 3 Files	1:00	12.50
-Read messages on 2 bulletin boards	0:15	3.13
-Check 10 stock quotes	0:05	1.24*
-Read today's news	0:10	2.08
-Play MegaWars III	0:30	6.25
Total hrs. non-prime/ 1200 baud	2:00	

Total Cost . . . \$25.70

Network surcharge \$.50 *\$.02/quote surcharge non prime

It doesn't take a computer to figure out the difference.

The difference between the GEnie™ service and CompuServe® could make a big difference to you. Here's why. GEnie's rate for 1200 baud access is just \$6 per non-prime hour*. There's more than twice as much. Which means that with GEnie you can stay online longer for a whole lot less.

And that means more time to enjoy more of GEnie's services. Like valuable computer RoundTables.

Exciting multi-player games. Useful financial information and much more. All at hourly rates designed to allow you to spend more time online. Not more money.

And with GEnie signing up is as easy as one, two, three.

- (1) Set your modem for local echo (half duplex), 300 or 1200 baud.
- (2) Dial 1-800-638-8369. When connected, you just enter HHH.
- (3) At the U#= prompt simply enter

XTX99684, GEnie then RETURN. And have a major credit card or your checking account number ready. For information in the U.S. or Canada, call 1-800-638-9636. Or write GE Information Services, 401 North Washington, Rockville, MD 20850.



We bring good things to life.

*Applies only in U.S. Mon.-Fri. 6PM-8AM local time and all day Sat., Sun., and national holidays. Subject to service availability. Some services may be subject to a surcharge. Prices effective May 1, 1989.

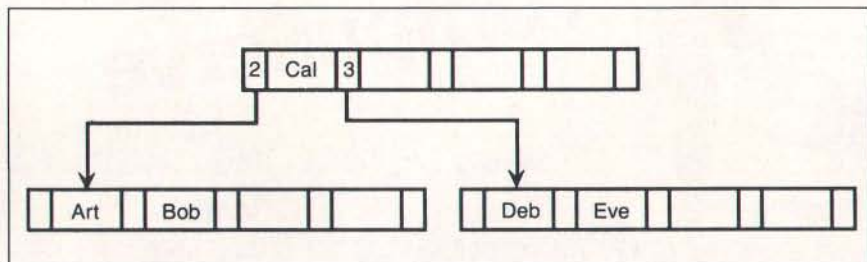

Figure 1: Reader Spear's B-tree.

fresh tree: Art, Bob, Cal, Deb, and Eve (see figure 1).

Following Grehan's directions, an inorder traversal would return Deb as the next key greater than Bob, while the true successor, Cal, would be missed altogether. When the pseudostack is popped, the parent key whose right-node pointer will be followed is the inorder successor. This error renders SEEK_NEXT_KEY and DELETE_KEY useless. Once a parent-key successor key has been found, the search must drop down to a leaf to find up to four successors. SEEK_NEXT_KEY provides no way to read the leaf node. The SCANKEY routine could be called to do this. If a parent node holds more than one key, a second index pointer would be needed so that subsequent pops reference the correct key. KEYOFFSET can't be used for both purposes.

There is another error in the SEEK_NEXT_KEY module in line 7, where a GOTO references an undefined line label, L1:. Jumping to L2:, the only line label in the example, sends the code into the middle of a loop, which is probably not good programming practice.

I hope that corrected code examples will be made available so that we can see what Grehan actually intended. I have enjoyed the series very much despite the frustration.

Robert J. Spear
Accokeek, MD

The sentence you quote was in a paragraph describing those keys that are not on a leaf node. And it is true that the inorder successor of a key on a nonleaf node is always on a leaf node. In any case, you're right. It's false that every key's inorder successor is on a leaf; I should have been more explicit. I'm sorry to have led you astray.

In light of this, I think you'll see that SEEK_NEXT_KEY does work for the example you've given (refer to listing 4 in Part 1). Assume that you're at BOB (KEYOFFSET=1, IFLAG=0) and you perform a SEEK_NEXT_KEY. Since the

file is not rewound and IFLAG=0, the routine drops down past all those comments, increments KEYOFFSET, and sets IFLAG to 1 (this means the routine is pointing to BOB's right key pointer, which is empty). The WHILE loop doesn't execute, since the key pointer is empty, so the routine zooms back up to the start of the REPEAT loop. Since IFLAG equals 1, the first IF statement executes, but since KEYOFFSET does equal the number of keys on the node (namely, 2), the second IF does not execute. Nor does the third—the pseudostack is not empty. So the routine pops the pseudostack and reads in the node containing CAL. Popping the stack also sets KEYOFFSET to 0. Now the routine hits the ELSE and returns to the beginning of the REPEAT loop. Again, the first IF statement is executed (IFLAG still equals 1), but now the second IF executes (since KEYOFFSET does not equal the number of keys on the node). So IFLAG is set to 0, and the routine returns with everything pointing to CAL.

Finally, you are absolutely correct that label L2 should have been L1. Several people have pointed that out, and I shall probably pay for it for the rest of my life.

—Rick Grehan

Tricky Terms

I found Christopher Greaves's challenge ("Ackerman Exercise," Letters, November 1988) to calculate values of the recursive function Ack(m,n) impossible to resist, and I spent a number of evenings investigating the problem. A microcomputer proved inadequate to deal with the numbers involved, so I had to resort to brainpower and pencil.

As m increases, the value of the function increases ever more rapidly, and for i=0,1,2,...,n produces the following series:

$$\begin{aligned}
 \text{Ack}(0,i) &= 1,2,3,4,\dots,n+1 \\
 \text{Ack}(1,i) &= 2,3,4,5,\dots,n+2 \\
 \text{Ack}(2,i) &= 3,5,7,9,\dots,2n+3 \\
 \text{Ack}(3,i) &= 5,13,29,61,\dots,(2^{(n+3)}) \\
 &\quad -3
 \end{aligned}$$

$$\begin{aligned}
 \text{Ack}(4,i) &= 13,65533,\dots, \\
 &\quad (2^{(\text{Ack}(4,n-1)+3)} - 3)
 \end{aligned}$$

The value of Ack(4,2) is approximately 2.17E19727 and would take more than four pages to type, and Ack(4,3) is already vastly greater than a googolplex.

Greaves challenges his students to "deliver" to him the value of Ack(5,5), which can be simplified to

$$\begin{aligned}
 \text{Ack}(5,5) &= \text{Ack}(4,\text{Ack}(4,\text{Ack} \\
 &\quad (4,\text{Ack}(4,\text{Ack}(4,65533))))
 \end{aligned}$$

His carefully chosen words hide the fact that there is no transport company large enough to handle that task, nor is there sufficient paper in the world on which to express the value.

A. J. McCutcheon
Nedlands, Australia

How to Get BYTE Listings

I just finished reading "The Token Ring" by Brett Glass (January). Congratulations are in order for a well-written article that was easy to understand.

How do I go about getting the IBM demo of the Token Ring, given that I do not have access to BIX?

Chris Smith
Whitehorse, Yukon, Canada

BYTE listings are also available on BYTENet (our free BBS), on disk from BYTE (most issues have an order card bound in), and from correspondent BBSes worldwide. Thanks for your interest.—Ed.

Recipe for Comparing Compilers

"Smoothing Out C" by Steve Apiki and Jon Udell (Product Focus, February) was an informative article. However, the result that "Turbo... did poorly on the floating-point test" prompts me to relate data comparing Microsoft C and Turbo C using routines from the book *Numerical Recipes in C* by William H. Press et al. (New York: Cambridge University Press, 1986.) (The FORTRAN/Pascal version of this book was reviewed in the January 1987 BYTE.)

I needed a microcomputer C compiler for a spectral estimation project. Originally, I had intended to use the Microsoft compiler, since several coworkers had been using it and it had always been reliable. For this project, good numerical accuracy was far more important than execution speed. Although Microsoft C and Turbo C produced identical results for most of the *Numerical Recipes* routines that I intended to use, Turbo C pro-

continued

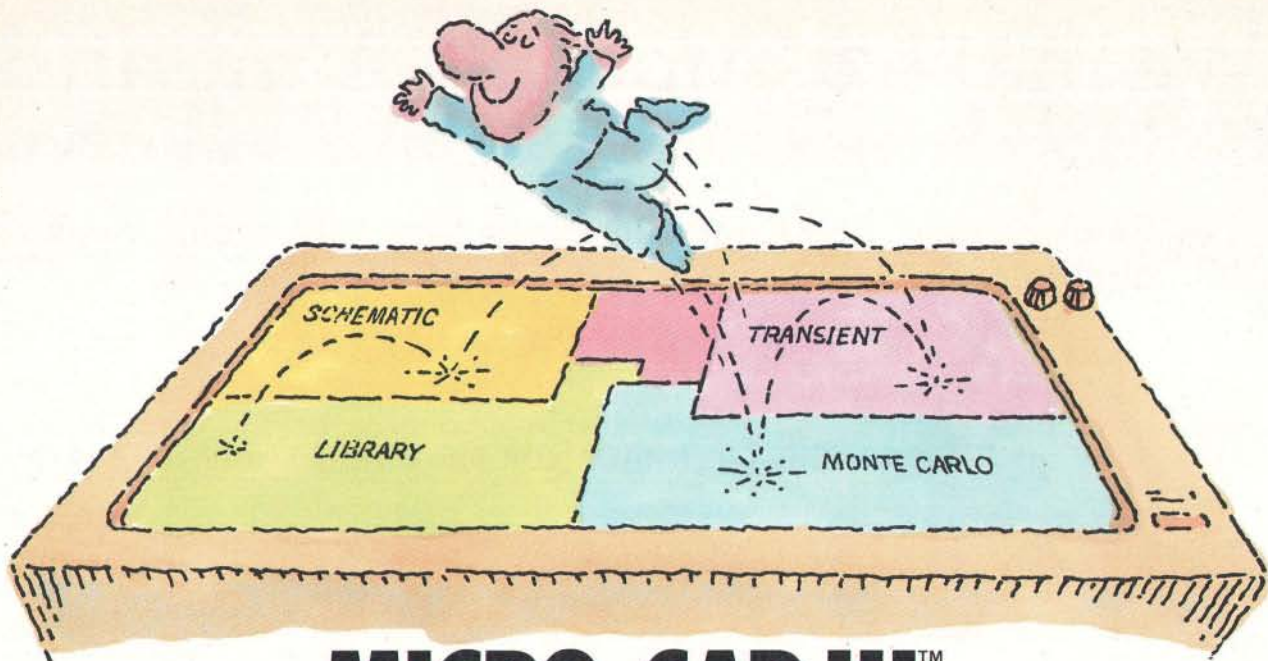

MICRO-CAP III.™

THIRD-GENERATION INTERACTIVE CIRCUIT ANALYSIS. MORE POWER. MORE SPEED. LESS WORK.

MICRO-CAP III,™ the third generation of the top selling IBM® PC-based interactive CAE tool, adds even more accuracy, speed, and simplicity to circuit design and simulation.

The program's window-based operation and schematic editor make circuit creation a breeze. And super-fast SPICE-like routines mean quick AC, DC, Fourier and transient analysis—right from schematics. You can combine simulations of digital and analog circuits via integrated switch models and macros. And, using stepped component values, rapidly generate multiple plots to fine-tune your circuits.

We've added routines for noise, impedance and conductance—even Monte Carlo routines for statistical analysis of production yield. Plus algebraic formula parsers for plotting almost any desired function.

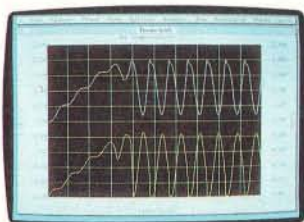

Transient analysis

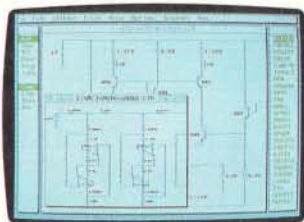

Schematic editor

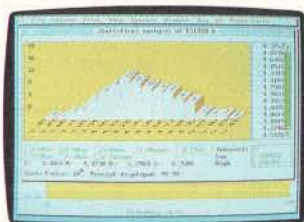

Monte Carlo analysis

Modeling power leaps upward as well, to Gummel-Poon BJT and Level 3 MOS—supported, of course, by a built-in Parameter Estimation Program and extended standard parts library.

There's support for Hercules® CGA, MCGA, EGA and VGA displays. Output for laser plotters and printers. And a lot more.

The cost? Just \$1495. Evaluation versions are only \$150.

Naturally, you'll want to call or write for a free brochure and demo disk.

Spectrum

1021 S. Wolfe Road,
Sunnyvale, CA 94086
(408) 738-4387

MICRO-CAP III is a registered trademark of Spectrum Software.
Hercules is a registered trademark of Hercules Computer Technology.
IBM is a registered trademark of International Business Machines, Inc.

We make a super VGA monitor



NEC introduces the best VGA monitor you can buy. MultiSync® 2A.

The first monitor that takes our award-winning multiple frequency technology and customizes it to the needs of the VGA user.

MultiSync 2A is both affordable and uncompromised. And completely compatible with all VGA modes. In short, it performs brilliantly. But what's equally important, it allows you to move effortlessly to the next major graphics standard: SuperVGA.

All this in a monitor that gives you a 14" non-glare screen on a tilt-swivel base, for nearly 30% more viewing area than standard 12" screens, and a new cabinet that's not only functional but is designed to look as good from the back as it does from the front.

MultiSync 2A. One super VGA monitor.

VGA mode shown at 320 X 200

C&C

Computers and Communications

that's also a SuperVGA monitor.



But that's only part of the story. NEC also introduces the best SuperVGA monitor you can buy. MultiSync® 2A.

The first monitor that takes our award-winning multiple frequency technology and customizes it to the needs of the SuperVGA user. MultiSync 2A senses the software you're using and makes the switch from a VGA monitor to SuperVGA, the new standard developed by NEC and recognized by VESA, the Video Electronics Standards Association. SuperVGA delivers a maximum resolution of 800 x 600, which is 56% higher than VGA.

And since you're most likely buying a board that goes beyond VGA, your monitor should too. For literature call 1-800-826-2255. For technical details call NEC Home Electronics (USA) Inc. at 1-800-FONE-NEC.

MultiSync is a registered trademark of NEC Home Electronics (USA) Inc.

MultiSync 2A. One SuperVGA monitor.

© 1989 NEC Home Electronics (USA) Inc.

NEC

EZ-DOS

Break the stranglehold on your PC.

Digital Research & 2001 Sales have developed EZ-DOS as an enhanced replacement for your current DOS.

Now you can use the sophistication of EZ-DOS instead of accepting the limitations of another DOS.

The main features of EZ-DOS are:

- * DOS compatibility
- * Multiple 512 megabyte partitions - quit dissecting your hard disks
- * Password protection of files and directories
- * Full screen text editor
- * On-line HELP for command syntax
- * Command history
- * LIM 4.0 Extended memory driver
- * Menu based installation that works with all compatibles

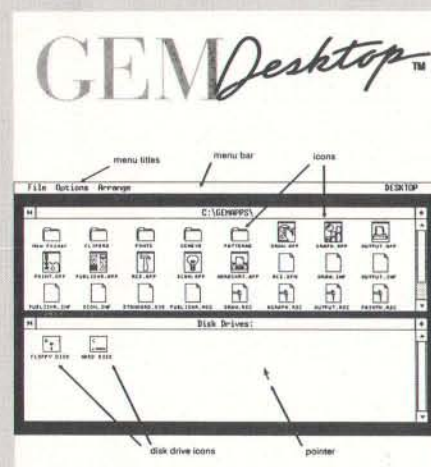

- * A true graphic, windowing operating environment - GEM/3 Desktop is our user interface.
- * Inexpensive - compare costs

EZ-DOS 4.1 Deluxe..... \$79.00
 plus True BASIC..... \$99.00
 plus serial Mouse..... \$139.00
 plus T.BASIC & Mouse.. \$159.00

2001 Sales, Inc.

16580 Harbor Blvd., Ste. D
 Fountain Valley, CA 92708.

Tel: (714) 531-6551

Fax: (714) 531-8546

Dealer, Distributor & OEM Inquiries welcome.
 VISA and Master Card accepted.

LETTERS

Table 1: Results using the xmemcof.c driver routine. Published results appeared in Numerical Recipes in C.

Index	Published	VAX-C	Turbo C	Microsoft C
1	1.261539	1.261540	1.261540	1.262617
2	-0.007695	-0.007694	-0.007694	-0.009724
3	-0.646778	-0.646779	-0.646779	-0.646527
4	-0.280603	-0.280603	-0.280603	-0.279950
5	0.163693	0.163692	0.163692	0.163249
6	0.347674	0.347676	0.347676	0.347373
7	0.111247	0.111247	0.111247	0.111045
8	-0.337141	-0.337142	-0.337142	-0.336187
9	-0.358043	-0.358043	-0.358043	-0.358086
10	0.378774	0.378774	0.378774	0.378403

Table 2: Results using the xspetrm.c driver routine (overlapped case).

Index	Published	VAX-C	Turbo C	Microsoft C
1	—	0.001993	0.001993	0.001786
2	—	0.001461	0.001461	0.002544
3	—	0.072356	0.072356	0.147874
4	—	0.062723	0.062723	0.107431
5	—	0.097625	0.097625	0.000332
6	—	0.014102	0.014102	0.000512
7	—	0.000089	0.000089	0.000113
8	—	0.000210	0.000210	0.000131
9	—	0.000052	0.000052	0.000037

vided better accuracy in the two routines memcof.c and spetrm.c.

I compared compilers by using driver routines supplied in the companion book *Numerical Recipes Example Book (C)*. This book often gives the answers obtained when the routines were run by the authors. I tested the book's sample routines xspetrm.c and xmemcof.c using Microsoft C, Turbo C, and VAX-C (the latter on a DEC VAX-11/780 minicomputer). The results in tables 1 and 2 show why I selected Turbo C.

Robert C. Briggs
 Los Altos, CA

Artificial Distinction

This is in reference to the correspondence on "Minds vs. Programs." Dr. R. J. Ellis ("Factoring the Unforeseen," Letters, February) makes an artificial distinction between "crystallized consciousness" and "living consciousness." Isn't there essentially a confusion as regards the terminology? Humans use algorithms that encompass emotion, self-motivation, and reprogramming capability. A computer program that uses an equivalent algorithm would have all the "human" capabilities listed by Ellis.

The question that remains to be answered is whether the human mind is ca-

pable of developing such an algorithm. I believe a human as well as an "artificial" mind would be capable of just that.

Dr. Mohammed I. Saleem
 Safat, Kuwait

MS-DOS Computer Server

I'm writing in response to Nicholas Birkett's letter ("Multiuser Advantages," February). Birkett complained about the impossibility of having a "computer server" under MS-DOS. He's mistaken. I know exactly how to accomplish what he wants.

To begin, Birkett is right in asserting that it's impossible for one machine on a LAN to initiate a job on another machine on the LAN. This can be accomplished, although in a roundabout way:

1. Set up the machine that is to do the work in one of the following ways: as a client, in which case only the LAN server(s) can initiate jobs on it; or as a client/server, in which case all clients on the LAN can initiate jobs on it.
2. Set up an initiator process on the machine that is to do the work. I'll describe the initiator process and ways of making it recognize jobs that are waiting to be initiated below.

continued

Designed for desktop graphics, priced to be personal.

Drawing Board to Board Room

Plot your designs, present your plans, and illustrate your point with the new HI Image Maker.™ Houston Instrument's newest plotter can improve all your images at a price that makes personal productivity gains affordable.

Precision CAD or Graphic Presentations

Your HI Image Maker uses a variety of technical pens on vellum or presentation bond—and produces vibrant color graphics on transparencies, paper, or vellum. Drawings on media up to 11×17 inches can be produced quickly and beautifully at a resolution of one thousandth of an inch.

Confidence and Value

Industry experts agree, HI drafting plotters defined the price-performance standard for PC-based CAD plotters. The HI Image Maker is a product you can buy with confidence. Priced at only \$1295,* you can use this plotter throughout your company—or keep it for yourself!

For details, call 1-800-444-3425 or 512-835-0900.

*U.S. suggested retail price. Subject to change.

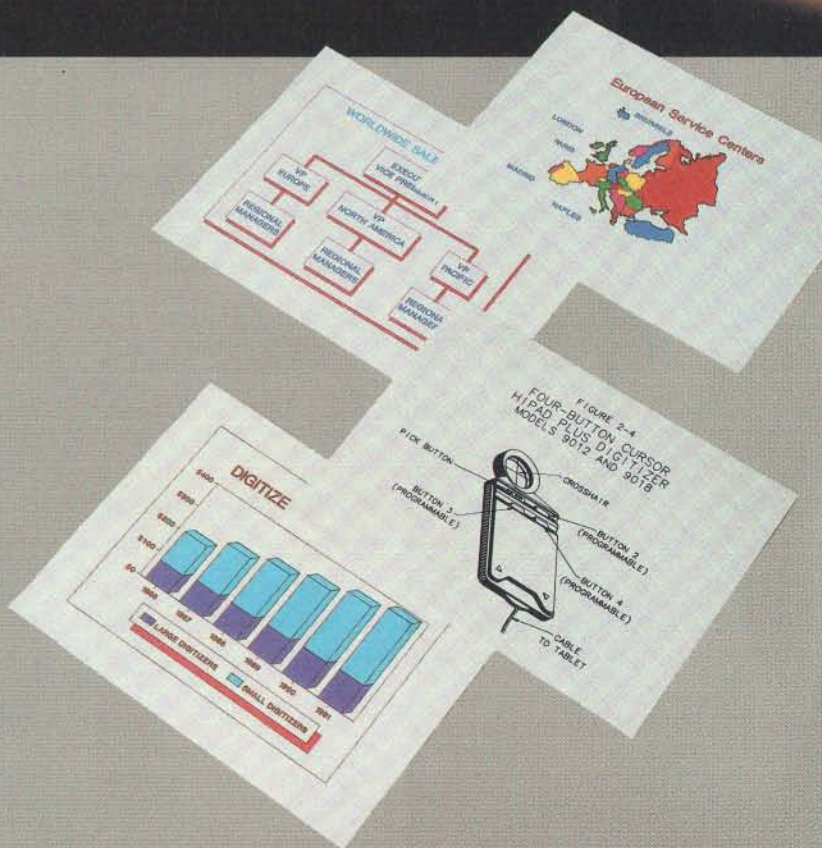

HOUSTON INSTRUMENT

A DIVISION OF AMETEK

8500 Cameron Road, Austin, TX 78753

Houston Instrument and HI Image Maker
are trademarks of AMETEK, Inc.

Circle 132 on Reader Service Card

3. Mount the job to be done as an executable (.BAT, .COM, or .EXE) file on the server or on the machine that will do the work. This is possible because that machine, as a server, will have at least one logical disk on which clients can write.
4. Sit back and wait for the job to be completed.

What I've described is inherently a batch system, and because the only way to have intermachine communications on

a LAN is through semaphore files mounted on the server, it cannot easily be made interactive. It is conceptually identical to the way in which print servers work. It can all be done under MS-DOS, and it requires surprisingly little programming.

All the initiator process has to do is idle until something that it recognizes as an executable file turns up. When an executable file appears, the initiator runs it and resumes waiting.

I use a .BAT file to set JOBNUM instead of setting it directly to allow clients to know the next job number and because the batch file will survive shutdowns.

A practical application of this little scheme with clients running jobs that have been teed up on the server is to have PCs on a LAN function as a loosely coupled multiprocessor machine. The individual processors all run the same job(s) in parallel. I'm now setting up such a machine, and my version of RunJob is actually a .BAT file.

In Birkett's case, where clients send jobs to a server/client, the client has to know the next available job number and copy the executable file, with the right name, to the server.

As long as his executable files take the inputs/commands they need as command-line arguments or from a file, which will also have to be on the server, Birkett should be able to use the logic sketched above to get a machine on a LAN to function as a computer server.

Daniel W. Fromm
Cherry Hill, NJ

Clarifying ConvertUnits

Many thanks to BYTE and Jerry Pournelle for the uplifting and encouraging mention of our ConvertUnits software desk accessory and HyperCard stack (Computing at Chaos Manor, February). We hope we can increase enthusiasm for our recently released product by clarifying several comments.

Jerry says that the manual doesn't tell you that you must copy the database files onto the hard disk. The section entitled "Preparing Working Copies," on page 20 of our manual, states, "Copy the Category documents you will be using to your working disks" and is followed on the next page by "With a hard disk system, copy all of the Category documents that you would use regularly." About the user interface, Jerry states, "now you have to let go of the mouse and press Return, because there's no 'activate' button." There is—the "=" icon, which is described throughout the manual in the "Tutorial" and the "Using" sections. We specifically implemented the "=" conversion button for power users to activate multiple conversions without having to let go of the mouse.

As Macintosh software developers, we are always interested in all insights to enhance the ConvertUnits interface. We would appreciate receiving any other suggestions that Jerry or other ConvertUnits users may have for additional refinements to the program. As longtime

continued

Dr. J. Magerman
Massachusetts General Hospital
Vascular Biophysics

Mark T. Yost
SynTex Research
Tobacco Press Monitoring

William Ott, S.J.
John Carroll University
Seismic Monitoring

Thomas Blair
Advanced Nuclear Fuels
Nuclear Fuel Rod Testing

Institute of Critical Care Medicine
CPR Research

Ernest Franke
Southwest Research Institute
Robotics Research

Dr. C.M. Ferrario
Cleveland Clinic Foundation
Cardiovascular Research

CODAS...
**Preferred by
Researchers
with Eyes.**

For IBM PC, AT, PS/2 and compatible computers

When you need to see what you're acquiring when it happens, you need real time performance. You need CODAS from Dataq Instruments. The only real time PC-based waveform recorder.

50 kHz Real Time Monitoring

Forget in-the-dark data acquisition sessions. CODAS turns your computer's monitor into a multichannel heads up display, plotting every data point as it happens. Our patent-pending smooth scroll waveform presentation and unequalled plotting speed keep you in command. No guessing. No surprises.

50 kHz Real Time Recording to Disk

Focus your attention on the real time display while up to 16 waveforms simultaneously record to disk. To 50,000 samples per second, CODAS ensures a gap-free, continuous waveform record.

Waveform Playback and Analysis

Review megabytes of recorded signals on your monitor in seconds with the CODAS Playback/Editor. Then seamlessly extract, analyze, hard copy, translate, and export waveform information with simple keystrokes.

For the best way to see, record, and analyze your dynamic waveforms, call us at **1-800-553-9006**. Or write Dataq Instruments, Inc., 825 Sweitzer Avenue, Akron, Ohio 44311, (216) 434-4284.

DATAQ INSTRUMENTS, INC.
The way PC-based instrumentation should be



Natural selection provides unique passive protection for the porcupine.

The Activator - Natural Selection For Software Protection



Inventor and entrepreneur Dick Erett explains how "The Activator" provides sane protection for your intellectual property.

In any industry, just as in nature, the process of natural selection raises one solution above another. Natural selection is the most elegant of engineers.

In the area of software protection The Block has been selected by the marketplace as the solution that works. Over 500,000 packages are protected by our device.

For the past 4 years our philosophy has been; 'You have the right and obligation to protect your intellectual property.'

A New Ethic For Software Protection

In allowing end-users unlimited copies of a software package and uninhibited hard disk and LAN operation, The Block has created a new ethic for software protection.



By removing protection from the magnetic media we remove the constraints that have plagued legitimate users.

They simply attach our key to the parallel port and forget it. It is totally transparent, but the software will not run without it.

A New Technology For Software Protection

Our newest model, The Activator, builds on our current patented design, and establishes an unprecedented class of software protection.

We have migrated and enhanced the circuitry of The Block to an ASIC (Application-Specific Integrated Circuit) imbedded in The Activator.

This greatly improves speed and performance, while reducing overall size. Data protection can also be provided.

Programmable Option

The Activator allows the software developer the option to program serial numbers, versions, or other pertinent data known only to the developer, into the circuit, and access it from the program.

Once you program your part of the chip, even we have no way to access your information.

The ASIC makes emulation of the device
Circle 256 on Reader Service Card

virtually impossible. It also presents an astronomical number of access combinations.

Full 100% Disclosure

Since The Activator is protected by our patent we fully disclose how it works. Once you understand it, endless methods of protection become evident.

Just as no two snowflakes are the same, no two implementations of The Activator are identical. And like the snowflake the simplicity of The Activator is its greatest beauty.



We never cramp your programming style or ingenuity. Make it as simple or complicated as you desire.

Let us help safeguard what's rightfully yours. Please call today for additional information or a demo unit. *It's only natural to protect your software."*

1-800-333-0407 ext.105
In Connecticut 203-329-8870
Fax 203-329-7428



870 High Ridge Road
Stamford, CT 06905

SOLUTIONS

ASK BYTE

Bigger—

Vfeature Deluxe™ lets your DOS system use hard disks it thought it couldn't, all in one bootable piece—no artificial partitions! Span two drives into C: and boot from it, use MFM, RLL, ESDI, or SCSI. Interleave selection, physical format, security options included. DOS 3.1-3.3 \$120

DUB-14™ PCB takes a different approach to drive expansion, stretches your AT's Drive Table to support the drive you choose—MFM, ESDI, RLL, up to 2048 cylinders! Comes with setup and low-level format routines, works with UNIX, XENIX, Pick, Novell, DOS. \$95

Faster—

Vcache™ speeds disk operations, stores data in RAM so it's there for you next time you need it—no waiting! Optional delayed sector write, lookahead buffer. Works with any type of memory, caches up to 15 Mb, bundles accelerators for your diskettes, screens, and keyboard. DOS 2 - 4. \$59.95

Vopt™ defragments disks for quicker access. Run it every day and keep your drive as fast as new! In a few seconds at boot time, Vopt arranges all your files neatly in contiguous clusters so you won't waste any time reading them back. Bundles timing and diagnostic utilities. DOS 2 - 4 \$59.95

Safer—

Vlock™ protects your system and its data from vandals and accidents. System access passwords control booting, activity menus decide who does what to which files, even locks out Ctl-Break during boot! \$135

Easier—

Vtools™ is a slick set of disk management tools for DOS and OS/2. Display directories in whatever order you like, browse files and change or delete them, compare and update multiple versions, find and manipulate categories of files, and more! \$49.95

SEE YOUR DEALER OR CALL TOLL-FREE

1 (800) 284-3269

GOLDEN BOW SYSTEMS

 2870 5TH AVENUE
 SAN DIEGO, CA 92103

(619) 298-9349

FAX (619) 298-9950 TELEX 201520 GBS UR

MC/VISA US shpg/hdlg \$3 CA orders add 7%

Vfeature, DUB-14, Vcache, Vopt, Vlock, and Vtools are trademarks of Golden Bow Systems.

Mac users, we are also interested in all improvements in the use of Macs.

At GTA, the facility for individual users of ConvertUnits to "customize" the database tables has already generated many hours of analysis and discussion. In fact, our HyperCard stack version includes user-definable currency conversions. We are currently exploring several alternatives for including other user-definable databases in future versions of ConvertUnits, while still maintaining the strict integrity and accuracy of the database tables and numerical conversion factors. In any event, we are currently offering a database customizing service to purchasers.

We are particularly savoring Jerry's concluding remark that he has not seen a better unit-conversion program for the Mac—that was precisely our intention in developing ConvertUnits. It's an honor to have had our software reviewed in BYTE.

 John Lancaster
 President

 GraphicText Applications, Inc.
 Vancouver, BC, Canada

ASK BYTE

Missing Math Coprocessor

I am generally pleased with my Toshiba T1000 laptop. But it lacks a provision for a numeric coprocessor. Is there any way to add one? This little machine seems to be pretty popular; I suspect that the addition of an 8087 might make it even more popular.

 Wilton Sturges
 Tallahassee, FL

I suspect you're right. There is no coprocessor socket on the T1000, and adding one is a task I wouldn't advise you to undertake. If someone comes out with some sort of clip-on outboard, we'll let you know.—R. G.

Significant Difference?

I can usually understand product descriptions well enough to make purchase decisions, but I'm having difficulty understanding the difference between the 80386 and the less expensive 80386SX. There must be a reason for the price difference, or else the more expensive of the two would not sell. The idea of spending less money on a new system appeals to me, but I'd like to know what I'd be giving up in return.

 D. Gordon Gray
 Bramalea, Ontario, Canada

See our February cover story ("The Mac SE Takes Off" by Nick Baran).—R. G.

Protection, Please

I'll be grateful if you can help me get in touch with any company that makes reliable data-protection software. I have programs and data on my hard and floppy disks that I'd like to protect against unauthorized duplication.

 Mohammad Nasim
 Riyadh, Saudi Arabia

It sounds like you should contact BBI Computer Systems (14105 Heritage Lane, Silver Springs, MD 20906, (301) 871-1094), which offers a free demonstration disk of its Stopcopy software.

You may also want to check out the firms now offering what is referred to as "hardware key" copy protection. This is usually a small adapter that connects to the computer's RS-232C port. You distribute the adapter with your software, and protected programs verify the legality of the machine by looking for the hardware key. The key's special design permits normal serial-port activity to occur uninhibited. Two companies to investigate are ProTech Marketing (1804 West Southern Pkwy., Building A-112, Durham, NC 27707, (919) 490-4790) and Software Security (870 High Ridge Rd., Stamford, CT 06905, (800) 333-0407.

—R. G.

Speak Forth

I have a number of questions regarding the Forth programming language.

First, what is this 2K-byte kernel I keep reading about?

Second, how do you go about getting Forth started? If the kernel simply looks things up in a dictionary, how does anything get started?

Finally, I've read that there are many ways to implement "threaded code." What are the differences, and what are their pros and cons?

 T. Dunlap
 Ottawa, Ontario, Canada

I'll tackle your questions in order.

First, with regard to the 2K-byte kernel, I would have to know just which implementation of Forth you were looking at before I could make any accurate comments. The kernel is best described as the minimum amount of code and data you need to create a usable Forth environment. Of course, this is one of Forth's quirks: One person's view of a "usable" Forth environment may be quite different from another's. Still, a basic Forth sys-

continued

The New
804
Series

AFFORDABLE CONNECTIVITY

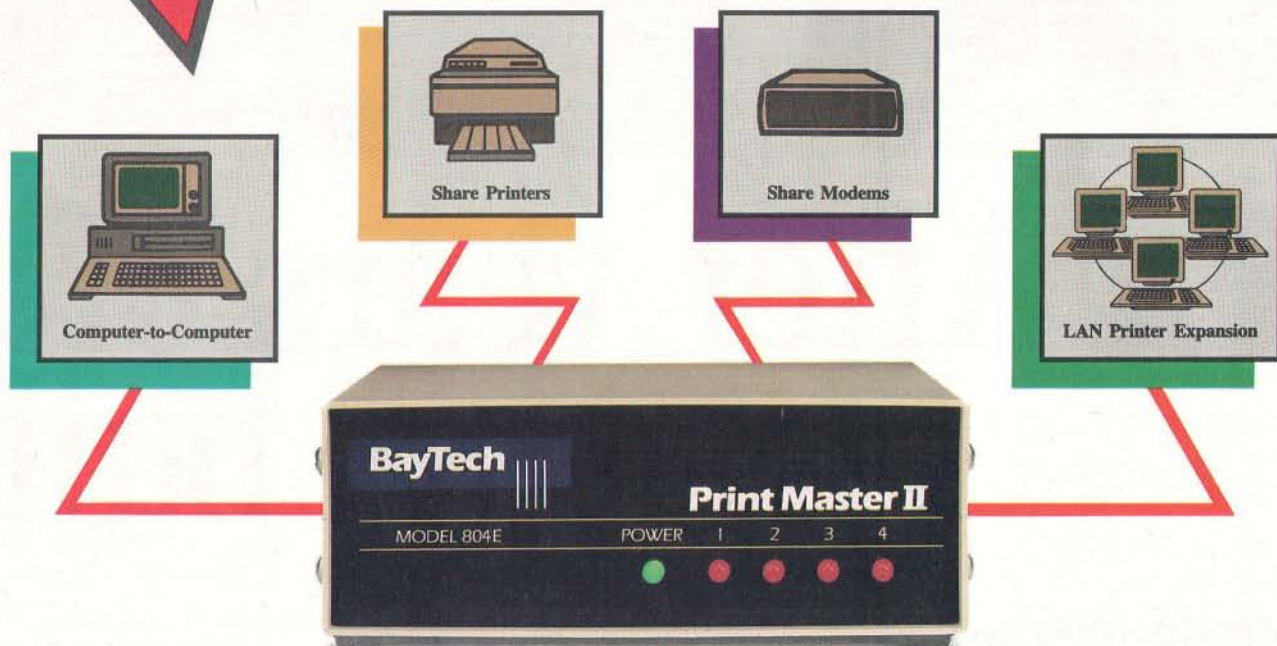

A VERSATILE LAN-ALTERNATIVE FOR \$395



THREE MODELS TO MEET YOUR APPLICATIONS

The Print Master® II 804 Series is BayTech's newest intelligent controller with four ports and a 256KB dynamically allocated buffer. Available in your choice of four serial ports (RS-232C or RS-422A), four parallel ports, or two serial and two parallel ports, the 804 Series offers affordable connectivity.

The 804 Series provides a cost-effective solution for users who want to maximize their resources. Each four port model allows you

Circle 38 on Reader Service Card (DEALERS: 39)

to connect any combination of computers, printers, and plotters for:

- ▶ printer sharing
- ▶ plotter sharing
- ▶ buffering of data
- ▶ LAN printer expansion

Models with serial ports allow you to also connect modems or any other RS-232C device for computer-to-computer communication and modem sharing.

The 804 Series allows simultaneous data input from computers, output of print data and full duplex communication between pairs of computers.

LAN APPLICATIONS

The 804 Series is ideally suited for expanding the printing capabilities of a LAN system. By acting

as a printer server, it can off-load network traffic and provide port expansion and extra buffering.

BayTech products are covered by a one-year warranty and are supported toll-free by a team of application engineers.

Call us today to learn how the new Print Master® II 804 Series can become your connectivity solution.

BayTech

Bay Technical Associates, Inc.
Data Communications Products Division
200 N. Second Street, P.O. Box 387
Bay St. Louis, MS 39520 USA
FAX: 601-467-4551

Telex: 910-333-1618 BAYTECH
Phone: 601-467-8231 or toll-free

800-523-2702



CSR 286/14



CSR 286/20 SL

After years of fi we built

Introducing the best built, best backed 286- and 386-based systems.

Since 1983, CSR has been a leading microcomputer maintenance provider. We repair all major brands - IBM[†], Compaq[†] and the best-known peripherals - for the largest dealer networks and third-party service companies nationwide. So when we decided to build our own 286- and 386-based systems we knew how to make them even better.

With CSR, you can put your confidence in a company that has it all - the service, support, performance and IBM compatibility you expect - but at prices that will surprise you.

The industry's first 2-YEAR warranty.

For the first full year we provide complete on-site service on all parts and labor. During the second year we'll repair or replace any parts that fail. This revolutionary warranty demonstrates the high degree of confidence we have in the quality and reliability of our computers.

Plus, when you call our toll-free Technical Support Hotline you'll be connected to a highly-skilled Customer Engineer (CE). Your CE will either fix the problem over the phone or dispatch a Service Engineer to your site - within 24 hours of your call - for prompt, professional problem resolution.

And what's best about this CSR-exclusive is that everything is included in the price of your computer!

High performance, not a high price.

CSR delivers high performance in every machine we make. Our 286/20 uses an Intel[†] based 80286 chip that runs at a blazing 20 MHz and outperforms most 386-based machines.

And unlike some of our competitors, we don't imbed the VGA or disk controllers on the mother board - that can just lock you out of future innovations. Instead, we provide a high-speed VGA controller which supports all VGA modes. And a totally IBM-compatible disk controller which features the latest in track-buffer technology to boost drive performance by an amazing 30% to 50%.

Compatible with reality.

You've invested a lot in software. That's reality. So we designed our machines to be 100% compatible with all your MS-DOS[®] and OS/2[®] software.

And we know you have software on both 3 1/2" and 5 1/4" media. That's why *all* CSR computers have both size drives - even the low profile, small footprint 286/20 SL. It's a convenience we've added without adding to the price.

Plus you'll find our high resolution high contrast VGA monitors and "clickable" keyboard to be consistent with your definition of how a computer should look and feel.

Compatible with your budget.

You may have computing needs that are incompatible with what *other* computer companies would like you to spend. Tell *us* the details of your needs. Then tell *us* your budget. And we'll build *you* a system that's compatible with both.

So if you want a better built, better backed computer system, compare warranties. Compare specifications. Then pick up the phone and call us at 800-366-1277. We'll deliver what you need at prices that will surprise you.

Full leasing options available.

We accept MasterCard, VISA and certified checks.

†The brands or product names mentioned are trademarks or registered trademarks of their respective holders. MS-DOS and OS/2 are registered trademarks of Microsoft Corporation.

CSR 386/20



CSR 386/25c



Doing their best, ours better.

CSR 286/14

CSR 286/14 SL

- 80286 Intel based microprocessor running at 14 MHz.
- 1 MB RAM expandable to 16 MB (8 MB on the system board).*
- Page mode interleave memory architecture.
- High speed VGA controller.
- Dual Diskette/Hard Disk Controller.
- 5.25" 1.2 MB or 3.5" 1.44 MB diskette drive.
- Enhanced 101 tactile "click" keyboard with copy holder and dust cover.
- Socket for Intel 80287 or Weitek math coprocessor.
- 1 parallel, 1 serial port and a Microsoft compatible bus mouse port.
- 8 industry standard expansion slots. **
- Power reset switch.
- Security keylock.
- AMI bios.
- Real time clock with battery backup.
- MS-DOS and MS-OS/2 compatible.

Popular Options

1 MB to 16 MB of high speed memory.
80287 math coprocessor.
Slim line case with one 5.25" and two 3.5" drive bays accessible.

NOTE: *Up to 8 MB in SL case. ** 5 expansion slots in SL case.

CSR 286/14 Hard Disk Drives	Monitors / Adapters		
	Monochrome	VGA Mono	VGA Color
20 MB 40 MS ST506	\$2,099	\$2,299	\$2,599
40 MB 40 MS ST506	\$2,299	\$2,499	\$2,799
40 MB 22 MS ST506	\$2,499	\$2,699	\$2,999
90 MB 18 MS ESDI	\$2,999	\$3,199	\$3,499
150 MB 18 MS ESDI	\$3,499	\$3,699	\$3,999

CSR 286/20 SL

CSR 286/20

- 80286 Intel based microprocessor running at 20 MHz.
- 1 MB RAM expandable to 16 MB (8 MB on the system board).*
- Page mode interleave memory architecture.
- High speed VGA controller.
- Track buffered high speed dual diskette/hard disk controller.
- 5.25" 1.2 MB or 3.5" 1.44 MB diskette drive.
- Enhanced 101 tactile "click" keyboard with copy holder and dust cover.
- Socket for Intel 80287 or Weitek math coprocessor.
- 1 parallel, 1 serial port and a Microsoft compatible bus mouse port.
- 8 industry standard expansion slots. **
- 3 speed selectable 8 MHz, 16 MHz or 20 MHz speed.
- Power reset switch.
- Security keylock.
- AMI bios.
- Real time clock with battery backup.
- MS-DOS and MS-OS/2 compatible.

Popular Options

2 MB to 16 MB of high speed memory.
20 MHz math coprocessor.
Slim line case with one 5.25" and two 3.5" drive bays accessible.

NOTE: *Up to 8 MB in SL case. ** 5 expansion slots in SL case.

CSR 286/20 Hard Disk Drives	Monitors / Adapters	
	VGA Mono	VGA Color
3.5" 1.44 MB Diskette Drive	\$2,299	\$2,599
40 MB 22 MS ST506	\$2,999	\$3,299
60 MB 18 MS ST506	\$3,299	\$3,599
100 MB 29 MS ST506	\$3,599	\$3,899

CSR 386/20

- Intel 80386 Microprocessor running at 20 MHz.
- 1 MB RAM expandable to 16 MB on the system board.
- Page mode interleave memory architecture.
- Socket for 20 MHz Intel or Weitek math coprocessor.
- 5.25" 1.2 MB or 3.5" 1.44 MB diskette drive.
- Track buffered high speed diskette/hard disk controller.
- Enhanced 101 tactile "click" keyboard with copy holder and dust cover.
- High speed 16 bit VGA controller.
- 1 parallel, 1 serial port and a Microsoft compatible bus mouse port.
- 200 watt power supply.
- 8 industry standard expansion slots.
- Power reset switch.
- Security keylock.
- AMI bios.
- Real time clock with battery backup.
- MS-DOS and MS-OS/2 compatible.

Popular Options

2 MB to 16 MB expansion memory options.
25 MHz Intel coprocessor chip.
Internal or external tape backup.

CSR 386/20 Hard Disk Drives	Monitors / Adapters			
	VGA Mono 1MB RAM	VGA Mono 4MB RAM	VGA Color 1MB RAM	VGA Color 4MB RAM
40 MB 22 MS ST506	\$4,099	\$5,199	\$4,399	\$5,499
66 MB 22 MS ST506	\$4,399	\$6,499	\$4,699	\$6,799
90 MB 18 MS ESDI	\$4,399	\$5,699	\$4,699	\$5,999
150 MB 18 MS ESDI	\$4,899	\$6,199	\$5,199	\$6,499
322 MB 18 MS ESDI	\$5,699	\$6,999	\$5,999	\$7,299

CSR 386/25c

- Intel 80386 Microprocessor running at 25 MHz.
- 1 MB RAM expandable to 16 MB on the system board.
- Advanced Austek Cache memory controller with 32K of high speed static RAM Cache.
- Page mode interleave memory architecture.
- Socket for 25 MHz Intel or Weitek math coprocessor.
- 5.25" 1.2 MB or 3.5" 1.44 MB diskette drive.
- Track buffered high speed diskette/hard disk controller.
- Enhanced 101 tactile "click" keyboard with copy holder and dust cover.
- High speed 16 bit VGA controller.
- 1 parallel, 1 serial port and a Microsoft compatible bus mouse port.
- 200 watt power supply.
- 8 industry standard expansion slots.
- Power reset switch.
- Security keylock.
- Award bios.
- Real time clock with battery backup.
- MS-DOS and MS-OS/2 compatible.

Popular Options

2 MB to 16 MB expansion memory options.
25 MHz Intel coprocessor chip.
Internal or external tape backup.

CSR 386/25c Hard Disk Drives	Monitors / Adapters			
	VGA Mono 1MB RAM	VGA Mono 4MB RAM	VGA Color 1MB RAM	VGA Color 4MB RAM
90 MB 18 MS ESDI	\$5,599	\$7,299	\$6,299	\$8,099
150 MB 18 MS ESDI	\$6,499	\$7,799	\$6,799	\$8,099
322 MB 18 MS ESDI	\$7,299	\$8,599	\$7,599	\$8,899

To order,
please call **800-366-1277**

Circle 69 on Reader Service Card

CSR

Computer Systems Research
We build ours better.
JUNE 1989 • BYTE 45

Infinitor™

PROGRAMMABLE EDITOR

Introducing the editor that's as good as you are

Infinitor puts new creative power in your hands and opens up editing possibilities ad infinitum.

Infinitor's powerful TPL™ Text Processing Language lets you emulate EMACS, VI or your favorite editor. Perform complex text processing functions. Compile while inside the editor. And create your own on-line references and commands.

Its Nimble Windows™ lets you edit 10 files at once without shuffling between files. You can select, size, position and split windows at a keystroke.

You also get unlimited file size, re-configurable keyboard, auto indent, block manipulation, search and replace, restore line, on-line help and more. All for \$150, with a money-back guarantee.

Isn't it time you had the editor that's as good as you are? Order now.
1-800-526-5368



AGRANAT SYSTEMS
PO Box 4415
Brockton, MA 02401-4415

For IBM PCs or
compatibles with 384K
or more, 5.25
inch format.

Definitions on disk

Choice Words gives you instant access to 80,000 dictionary definitions plus more than 470,000 synonyms from Merriam-Webster—the English language authority.

The dictionary contains definitions, usage notes and hyphenation points. The thesaurus contains synonyms, meanings for each synonym group and property inflects all responses.

Choice Words works with over 35 word processors on IBM-PC compatibles running MS-DOS and is available on either 5¼" or 3½" disks. Your system must contain a hard disk and at least 100K of free memory.

Whether you're writing, reading, or simply want to explore the English language in a new and exciting way, Choice Words is for you.

CHOICE WORDS™

\$99

1 9 8 8



BYE
AWARD
DISTINCTION

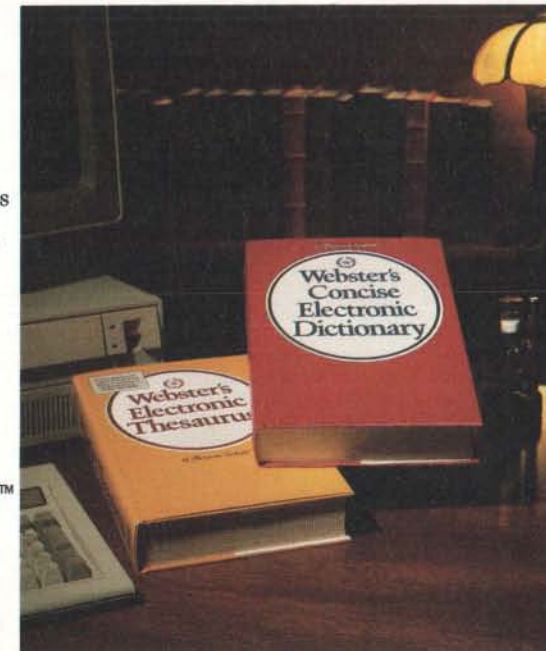

See your dealer, Or
order directly by call-
ing 1-800-323-0023,
(305) 566-3511 in FL)
Dealers: Order Choice Words
from Micro-D

PROXIMITY

Intelligence You Can Use™

3511 N.E. 22nd Avenue
Fort Lauderdale, FL 33308

tem usually takes up remarkably little code; early versions on single-board computers did quite well in 16K bytes of RAM. Most Forths for the IBM PC operate within a single 64K-byte segment (though it's easy to add provisions to address beyond that limit), and a program that would consume all of the 64K bytes is—by Forth standards—large.

If you want to see how Forth "gets started," I suggest that you obtain the source code for any of the more popular versions. Then sit down for an evening of intense reverse-engineering.

You'll find that most implementations load the instruction pointer register (often referred to as the IP) with the address of the next Forth word to execute. (Don't get the IP register confused with the code segment [CS] register; they are not the same thing.) When Forth boots up, the starting code sets the IP to point to the first word of the "inner interpreter." This is a sequence of Forth words enclosed in an infinite loop, whose actions are as follows:

1. Read the next space-delimited item from the input stream.
2. If it's a word in the dictionary, execute that word.
3. If it's a number, put it on the stack.
4. Go to step 1.

You'll find a more detailed description of this process in R. G. Loeliger's *Threaded Interpretive Languages* (BYTE Books, 1981).

Finally, there are three primary ways to implement threaded code (and there are probably more being invented all the time). Direct-threaded code means that the IP points to a memory cell whose content is the starting address of the code to be executed. Most Forths use direct-threaded code. Token-threaded code means that the IP points to a memory cell whose content is a token that the program can use to determine the true address of the executable code. Usually, this token is an offset into a table of addresses. Subroutine-threaded code means that the executable Forth code is nothing more than a series of subroutine CALL statements. *Mach II*, which is a Forth for the Macintosh, Amiga, and Atari ST machines, uses subroutine-threaded code. (*Mach II* is available from Palo Alto Shipping Co., P.O. Box 7430, Menlo Park, CA 94026.)—R. G.

Personal BBS

I have a question concerning the commercial BBSes that I can call with my
continued

The smart buy for PC Power Protection is now . . .

The Smart UPS For LAN's

. . . Reliable Protection From Data Loss

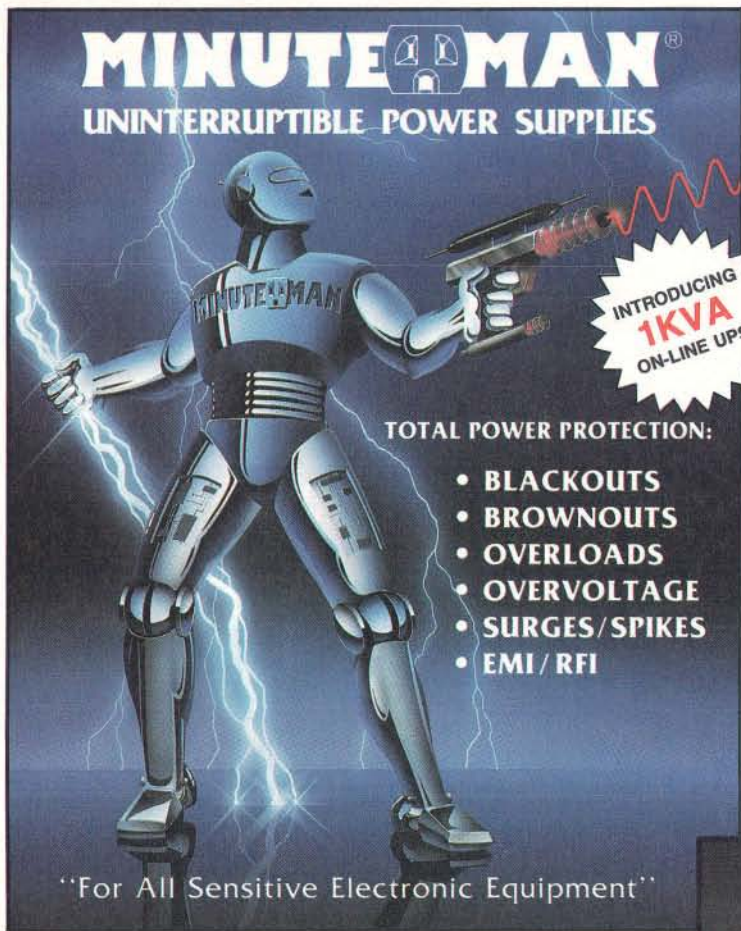

MINUTEMAN[®]
UNINTERRUPTIBLE POWER SUPPLIES

**INTRODUCING
1KVA
ON-LINE UPS**

TOTAL POWER PROTECTION:

- BLACKOUTS
- BROWNOUTS
- OVERLOADS
- OVERVOLTAGE
- SURGES/SPIKES
- EMI/RFI

"For All Sensitive Electronic Equipment"



- A unique software package that interfaces your LAN's and Minuteman UPS system for an automatic and orderly network shutdown due to power failures . . . before data loss occurs!
- Compatible with SCO XENIX 2.2.3
- Compatible with Novell Systems:
ELS 2.12 and above
Advanced Netware 2.10 and above
SFT Netware 2.10 and above
- Selectable power loss warning times and shut-down times
- Instantaneous user notification
- Also interfaces to Wide Area Networks
- Auto Shutdown of UPS for unattended operation
- The only software available that supports ELS Level II
- No Novell monitoring hardware required
- Network Manager Suggested Retail Price when purchased with a Minuteman UPS Model: \$199

Power Output	120 Volt Models	230 Volt Models
250 WATT	\$ 379.00	\$ 429.00
300 WATT	\$ 549.00	N/A
500 WATT	\$ 699.00	\$ 799.00
600 WATT	\$ 899.00	\$1049.00
900 WATT	\$1249.00	N/A
1000 WATT *	\$2249.00	\$2549.00
1200 WATT	\$1499.00	\$1749.00
1600 WATT	\$1999.00	\$2299.00

FOR L.A.N.
NOVELL LABS
TESTED AND
APPROVED
NetWare Compatible



* On-line model

Suggested Retail

- One millisecond transfer time *
- Synchronized sinewave *
- Full one year warranty
- Order-Ship same day

* 250 watt and 500 watt units offer 4 msec transfer time, PWM waveform

PARA SYSTEMS, INC.

1455 LeMay Drive
Carrollton, TX 75007

Telephone:
(214) 446-7363

1-800-238-7272

FAX: (214) 446-9011

TELEX: 140275 OMEGA

THINK BIG

Phar Lap Virtual Memory Manager.

It will let you write applications up to 5, 10, 15 megabytes or more for any 386 PC running MS-DOS*. *Forget about RAM limitations.* Your application can run on a machine with as little as 1 or 2 megabytes of memory.

Only Phar Lap 386IVMM* gives you demand-paged virtual memory capability so you can write mainframe-sized applications for the PC. Applications your customers can run on their 386 PCs now with no additional memory. No kidding. All you need is 386IVMM and our family of 386 development tools. Existing programs developed with our 386IDOS-Extender can be easily expanded with 386IVMM too.

Our tools let you take full advantage of the 386 protected mode architecture. Break the DOS 640K limit in the language of your choice; C, Fortran, Pascal, or Assembler.

For fast compact code, use 386IASM, our 80386 assembler that's upwardly compatible with the MASM* 8086 assembler. Existing DOS and mainframe applications written in a high level language are easily ported by recompiling. And 386LINK, our 32-bit native mode linker, puts it all together.

Debugging is made easy too. With our 386 symbolic debugger you can debug applications written in assembler or any high level language. Best of all, with Phar Lap's 386IDOS-Extender* you can run your native mode program on any 386-based PC running MS-DOS. And you have full access to DOS system services through INT 21.

NO COMPATIBILITY PROBLEMS

Phar Lap's tools are compatible with the industry's leading systems: DESKPRO 386*, IBM Model 70/80*, 386 clones and accelerator boards. Not only will your new applications be compatible with the leading systems, they'll run alongside all other DOS applications.

NO ROYALTY PAYMENTS

Once your 386 application is complete, all you pay is a low one-time fee to license 386IDOS-Extender for redistribution.

386IVMM is also developer friendly. Call to find out about our flexible run-time pricing.

You can unlock the entire DOS market now. Don't wait for OS/3.

- \$495 386IASM/LINK-Package includes 386 assembler, linker, MINIBUG debugger and the developer version of 386IDOS-Extender
- \$895 MetaWare 80386 High C* compiler
- \$595 MicroWay NDP Fortran-386* compiler
- \$195 386IDEBUG symbolic debugger
- \$295 386IVMM - developer version of the Phar Lap Virtual Memory Manager

(617) 661-1510

PHAR LAP SOFTWARE, INC.

60 Aberdeen Avenue, Cambridge, MA 02138

Fax: (617) 876-2972

"THE 80386 SOFTWARE EXPERTS"



Phar Lap and 386IDOS-Extender and 386IVMM are trademarks of Phar Lap Software, Inc. MS-DOS and MASM are registered trademarks of Microsoft Corp. DESKPRO 386 is a trademark of Compaq Corp. NDP Fortran-386 is a trademark of MicroWay, Inc. High C and Professional Pascal are trademarks of MetaWare Incorporated. IBM Model 70/80 is a trademark of IBM Corp.

personal computer. How is it that I can get through, even when many other people are using the system? Is one computer running the whole show, or is there a separate computer for each caller, all linked to a central database?

I would also like to know what I can do if I want to set up my own BBS, but I don't want to be limited to just one caller at a time.

Ross Del Duca
Sumner, WA

Welcome to the world of multiuser systems. The setups used by the larger BBSes (e.g., BIX, CompuServe, and The Source) are about as complex as you're going to get. Take BIX, for example. It's a multiprocessor, multiuser Unix system. At present, two CPU systems actually run the BIX program, and another pair act as communications "front ends" (i.e., answering incoming calls and handling the flow and buffering of data between BIX and the users).

Multiuser BBSes available to the end user are equally varied. I've seen people running multiuser BBSes by launching multiple tasks under Quarterdeck's DESQview. Galacticomm (11360 Tara Dr., Plantation, FL 33325) sells multi-line communications interfaces (up to 16 modems on a single board) and accompanying multiuser BBS software.

—R. G.

FIXES

• In the February 1989 Short Take entitled "Unix Tools for DOS," the statement that MKS Make contains the Mortice Kern RCS (Revision Control System) is in error. The RCS package must be purchased separately. The price for the RCS is \$189. Contact Mortice Kern Systems, Inc. (35 King St. N, Waterloo, Ontario, Canada N2J 2W9, (519) 884-2251).

• With reference to our First Impression on the Intel i860, "Intel's Cray-on-a-Chip" (May 1989, page 113), AMD is pulling its 29000 RISC chip only from one portion of the RISC market, workstations. AMD says that it is instead concentrating its attention on the embedded processor market and that new 29000-family products are on the way.

• The article "A CASE Workshop" in our April In Depth section contained an incorrect phone number. The correct phone number for Cadware (50 Fitch St., New Haven, CT 06515) is (203) 387-1853. ■

CHAOS MANOR MAIL

*Jerry Pournelle answers questions about his column
and related computer topics*

Pint-Size Unix?

Dear Jerry,

It seems that microcomputing has now reached puberty, with its attendant changes and confusions. In some ways, this is not an easy time to get into the act, but here I am with my brand-new IBM PC compatible. In looking around to try to decide where I should invest my learning time, I've hit on an idea about operating systems that might help people in a similar situation in the future.

Unix seems to have far more capabilities than I need now and requires far more memory than I have now. But some years down the road, I expect to need many of the facilities afforded by Unix, such as a good environment for writing programs in C and multitasking.

What about dividing Unix up into levels that could be later joined as user requirements increase? For example, level 1 might cover only that part of the operating system that would afford capabilities analogous to those afforded by CPM. Level 2 would add the next most used Unix capabilities, and so on, until successive levels included all of the Unix operating system and all the utility programs. Each level would include software patches as necessary to make that level operate independently but would look to the user the same as it would if he or she were using that part of the whole Unix system.

If that idea would work, it would make Unix practical for the very large and the very small computers, and it would give the user the chance to invest his or her learning time with more confidence that it wouldn't be lost. After all, the Unix system has been around long enough to prove its worth, and if it were possible to start small in Unix, at least you'd have a pretty good idea of where you were going.

From a user's point of view, is this a useful idea or a dumb idea? If it has any merit, I'm sure that the software people will look at it. Possibly they already have.

William Radford
Orlando, FL

Unix is pretty well, uh, unified, but in fact the various levels you describe can be done with Unix shells. American Management Systems has one such shell that tames Unix a lot.

The real problem with Unix is that, just when you think you've mastered it, something else happens. Users don't need surprises.

People who like Unix like it a lot. Most everyone else has a different view. . . .

—Jerry

Why Not Buy Two?

Dear Jerry,

I hope your friend Kelly Freas has not yet bought his Macintosh II. Since you own more than one computer, it's surprising that you didn't suggest that Kelly get more than one. For one thing, two people can work on two computers at the same time.

Of course, the real reason for Kelly to buy an Amiga 2000 and a PC clone, such as the Dell System 220, is that he would have the best artistic machine and the best business machine. He can get a color Amiga 2000 with 3 megabytes of RAM and a 40-megabyte hard disk drive for about \$3300. A color Dell System 220 with 1 megabyte of RAM and a 40-megabyte hard disk drive and DOS 3.3 costs about the same.

I think a color Mac II with 4 megabytes of RAM and a 40-megabyte hard disk drive costs about \$9000, but I'm guessing. A less powerful PC clone would save money.

You've already determined that the savings could be used to buy a color printer, among other things. This would give Kelly the best and more.

Barton C. Grooms
Amarillo, TX
continued

Jerry Pournelle holds a doctorate in psychology and is a science fiction writer who also earns a comfortable living writing about computers present and future. He can be reached c/o BYTE, One Phoenix Mill Lane, Peterborough, NH 03458, or on BIX as "jerry."

NEW BLAISE TOOLS



*The fastest way to create
powerful programs
with Turbo Pascal
5.0 and Turbo C 2.0!*

Blaise Computing, manufacturer of function libraries that offer easy-to-use solutions to your programming needs, introduces:

POWER TOOLS PLUS/5.0—\$149

—completely integrated and lightning-fast routines to help you:

- ◆ Add moving bar pull-down menus and windows to your user interfaces; *NEW!* ◆ Generate context sensitive help screens; *NEW!* ◆ Add easy-to-use date and time conversion routines; *NEW!* ◆ Let users choose from window oriented pick lists; *NEW!* ◆ Create and access "huge" data structures; *NEW!* ◆ Use multiple-line edit fields with fully configurable edit keys; *NEW!* ◆ Speed up your sorting with flexible in-memory sort routines; *NEW!* ◆ Add EMS support; *NEW!* ◆ Write TSRs and ISRs easily; ◆ Control DOS memory allocation; ◆ Create powerful programs in Turbo Pascal 4.0 & 5.0!

Turbo C TOOLS/2.0—\$149

—tight, fast, high quality functions to help you:

- ◆ Add easy-to-use mouse support for windows and menus; *NEW!* ◆ Quickly include virtual windows and menus; *NEW!* ◆ Integrate your windows and menus with Turbo C's text windows. *NEW!* ◆ Create context-sensitive help screens; *NEW!* ◆ Provide multiple-line edit fields with fully configurable edit keys; *NEW!* ◆ Use keyboard and video services (including enhanced keyboard and VGA); *NEW!* ◆ Write TSRs and ISRs easily; ◆ Create powerful programs in Turbo C 1.0, 1.5 and 2.0!

FREE with these products!

Source code, complete sample programs, a comprehensive reference manual with extensive examples, the Norton Guides Instant Access Program, and an online database. We also offer free technical support and a bulletin board system dedicated to technical issues.

Unleash your programming potential!

Blaise Computing offers programming tools that are fast, flexible and affordable. Call now to order or to ask for a free brochure on our full line of products for C and Pascal.

Put Blaise tools to the test!

If at any time during the first 30 days you are not completely satisfied with their speed and flexibility, we'll refund your money.

Call 800-333-8087 today!

BLAISE COMPUTING INC.
2560 Ninth St., Suite 316, Berkeley, CA 94710, (415) 540-5441
FAX: 415-540-1938

*Turbo C and Turbo
Pascal are trade-
marks of Borland
International.*



Well, Kelly got an Amiga; he was impressed with the graphics. Now Laura will have to figure out how to do his accounting, but if they get a Bridge Card (which makes the Amiga run vanilla PC software), I'll donate a copy of the accounting package that I wrote in 1978 and still use.—Jerry

One Man's Interpreter

Dear Jerry,

In his letter, "The Case for GOTOs," Mobolaji E. Osunsanya (Chaos Manor Mail, December 1988) states that an interpreter converts a line of source code to machine code and then immediately executes it. The interpreter that I use doesn't do any "code translation," but instead truly interprets the tokenized source code. I don't understand why the interpretation of tokenized source code should be any slower than the execution of compiled code.

A compiler often compiles the source code down to a bunch of subroutine calls to the library. An interpreter uses the token value for a keyword to immediately do a subroutine call to the appropriate routine.

The use of tokens allows source code storage in less memory and allows a simple and quick indexing into the "dispatch table" of addresses for the routines to handle each keyword. I believe that the difference between a token dispatch in an interpreter and a library routine call in a compiler is minor.

If, in performing a statement or function as specified by a keyword token, the interpreter finds another token, that routine is called. For example, PRINT INT(SQR(9)) calls the print subroutine. In executing the print subroutine, the INT token is found, resulting in the INT function being called.

In executing the subroutine called by

the INT token, the SQR token is found, resulting in SQR being called. Finally, while executing the SQR routine, the number 9 is found. This results in the ASCII FAC routine being called, which takes the ASCII 9 in the source code, converts it to binary floating-point, and places it in the floating-point accumulator (FAC).

The return from the ASCII FAC routine returns you to the SQR routine, which now finds the function argument in the FAC. The square root of the contents of the FAC is calculated and placed in the FAC.

The square root routine ends with a return (RTS), which returns you to the INT function, with the argument in the FAC. The INT function then places the result in the FAC and returns. At this point, the PRINT statement calls FOUT, which converts the contents of the FAC to ASCII, ready to print.

The line of source code was never converted to machine code; it was truly interpreted. I don't see how a compiler could do this much faster, other than realizing that the 9 is a constant, which could have then been stored in binary floating-point format, eliminating that conversion at run time. A smarter compiler (or programmer) would have realized that the whole statement calls for the printing of a constant, so the constant could have been calculated at compile time (or program writing time) instead of at run time.

Osunsanya suggests that the use of GOTOs instead of GOSUBs can result in improved program performance (speed, I assume) because of the lack of stack overhead. The interpreter that I work with handles GOSUBs much faster than GOTOs.

Actually, the GOSUB is slightly slower (because of stack overhead), but

the RETURN is much faster than another GOTO to get back. This is because a RETURN pulls the actual machine address of where to return (in the tokenized source code), while a GOTO must do a line-number search to locate its destination.

A line-number search is quite slow. It is a linear search from the beginning of the program (if the destination is before the current line number) or from the current location (if the destination is after the current line number).

The line-number search uses the line length stored after the line number in the source code to determine where the next line number is. It then "bounces" from line number to line number looking for the destination.

Since a compiler would substitute a JMP <Address> for the GOTO <Line-Number>, it would be considerably faster. I imagine that an interpreter could do something similar, but at this point I may be modifying the tokenized source code beyond recovery.

Harold Hallikainen
San Luis Obispo, CA

One of the neat things about writing this column is that I get letters from people who know what's going on inside these machines.

My understanding is that interpreted systems slow down when they are confronted with loops; each statement has to be interpreted yet again as the machine goes through another iteration. A compiler, on the other hand, translates that code once and for all and then executes the machine code however many times is required.

It may be that modern interpreters work differently, but that's certainly the way they worked when I was learning this stuff.—Jerry ■

Finally-- A Practical Way to Learn C Language Programming!

SPECIAL OFFER: 20% OFF
our usual list price of \$29.95!

PROGRAMMING USING THE C LANGUAGE

by Robert C. Hutchison and Steven B. Just 0-07-031541-8, U 070-031-1

This book combines a complete introduction for beginning programmers with more advanced topics such as sorting and searching, advanced pointer usage, and data structures. It provides numerous examples including four large case studies. Non-rudimentary topics such as functions and pointers are split into introductory and advanced sections.

Features:

- data types
- control constructs
- pointers
- functions
- structures
- unions
- storage classes
- sorting & searching
- lists, queues, stacks
- hashing, bitmaps
- resource allocation
- data representations
- ANSI C
- UNIX and DOS



For your copy call McGraw-Hill: Your Computer Publisher at 1-800-338-3987

If You Want To Talk Fast DBMS Call 1-800-db RAIMA And Start Screaming

You'll be screaming, all right. db_VISTA III from Raima Corporation combines the flexibility of a relational DBMS and the lightning speed of the network database model.

C db_VISTA III is written for C Programmers.

Source code available. The interactive database utilities and outstanding documentation make db_VISTA III easy to learn. All applications are portable to VMS, UNIX, OS/2, MS-DOS, even Macintosh. No royalties.

db_VISTA III is Fast. Using benchmarks originated at PC Tech Journal Laboratories, db_VISTA III measured 3 to 12 times faster than the average relational database! Call us and we'll send you the results.

Relational and Network Model Technology for Programming Flexibility. Retrieve a record fast using the relational keyed access method

db_VISTA III Database Development System		
Features	Yes	No
db_VISTA 3.1 High Performance DBMS:		
Single and Multi-User available	✓	
Relational B-tree Indexing	✓	
Network Database Model	✓	
Multiple database access	✓	
Referential integrity	✓	
Automatic recovery	✓	
Record & File locking	✓	
RAM resident		✓
db_QUERY 2.1 SQL-based Query:		
Relational Query & Report Writer	✓	
db_REVISE 1.0 Database Restructure Program:		
Total database redesign/restructuring	✓	
Operating Systems*: VMS, ULTRIX, UNIX	✓	
BSD 4.2, SunOS, XENIX, MS-DOS,	✓	
Macintosh and MS Windows. OS/2 compatible	✓	
C Compilers*: Most compilers supported	✓	
C++ compatible	✓	
LANs*: 3COM, Novell, Banyan, AppleShare	✓	
WKS Library:		
Read & Write WKS, WK1 & DBF files	✓	
SOURCE CODE AVAILABLE:	✓	
ROYALTIES: (Absolutely not!)		✓✓

*Other environments are supported; call for complete list.

db_VISTA III™
Database Development System

and all related records can be immediately available using the network model. You decide how to combine these for best application performance.

SQL Support with SQL-based db_QUERY, db_VISTA III's relational query and report writer.

db_VISTA Puts You in Some Fast Company.

Thousands of C programmers in over 50 countries worldwide use db_VISTA III, including APPLE, ARCO, AT&T, EDS, Federal Express, Hewlett-Packard, IBM, NASA...

Don't wait. Call Raima for more information about how you can build applications that are *screaming-fast!*

Call 1-800-db RAIMA
(That's 1-800-327-2462)

Prices start at \$695.

RAIMA™
CORPORATION BY69

Raima Corporation, 3245 146th Place S.E., Bellevue, WA 98007, U.S.A. Tel: (206) 747-1991 Telex: 6503018237 MCI UW FAX: (206) 747-1991 Texas: (214) 231-3131
International: U.K.: (0992) 500919 Germany: (0)212/252-2110 France: (0)1 725 0410 France: (1)46092828 Benelux: 31(02159)46 814 Sweden: (013)124780
Italy: 0-57554711 Denmark: (2)887249 Singapore: (687)345 Australia: (02) 959 5122 Japan: (03)473 7432 Taiwan: (02)511 3277 © 1989

CLEO is your SNA, BSC and Coax Gateway



VMS
UNIX
XENIX
PC-DOS
Macintosh
NetBios LAN

Sharing Information

Whatever your industry, your computers need to share information with your mainframe. Or, they need to exchange data with other computers. In either case, you need a total communications solution. You need software, hardware interfaces and modems that all work together smoothly. You need CLEO!

CLEO software products allow your computer to communicate with mini-computers and mainframes, and to emulate their workstations. Since 1981, CLEO has provided communications between micros, minis, and mainframes for the automotive, insurance, medical and banking industries. Today over 78,000 CLEO users worldwide are running on all major computer brands. The greatest number of these users run CLEO software on IBM Personal Computers and NETBIOS LANs.

Complete Software/Hardware Package

Every CLEO package contains all the software and hardware accessories you'll need. Your selected CLEO SNA, BSC, or Coax software is packaged with 1) an internal modem card for dial-up applications, or 2) an interface card and cable for use with your existing modem, or 3) a Coax card for local connectivity. There's no waiting for non-CLEO add-ons. And, you get prompt, single-source service.



Package prices range from \$795.00 for most stand-alone packages, up to \$1,995.00 for the 32-user SNA gateway.

Call us today to discuss your application.

CLEO Software
2652 Eastrock Dr.
Rockford, IL 61109
FAX 815/397-6535

Headquarters:

USA: **1-800/233-2536**
Canada: 514/484-8787
International: 815/397-8110

Sales and Distribution:

Canada, East: 800/361-3185
Canada, West: 800/361-1210
Canada, Montreal: 514/737-3631
Colombia, S.A.: 12172266
Denmark: 02 94 81 19
England: (0993) 776543
Italy: (0331) 634 562
Mexico City: 550-8033
Sweden: 468311780
W. Germany: 06151 55095



BOOK REVIEWS

The Chip War

by Fred Warshofsky

Scribner's, New York: 1989,
448 pages, \$22.50

Reviewed by Hugh Kenner

The way it was told to Fred Warshofsky, here's how Sony cracked the U.S. TV market, with "a strategy that might have been drawn by a Go-playing Shogun":

Said Sony to RCA, "Look, we can sell you your low-end model, which you are selling to Sears, cheaper than you can make it." RCA said, "Great," bought it from them, put an RCA label on it, and went on fencing it to Sears.

Said Sony to Sears, a few years later, "We can sell you this same set cheaper than RCA can and put a Kenmore label on it." So the TVs next flowed from Sony straight to Sears/Kenmore, while RCA, noting a mysterious drop in demand, cut back its orders.

Then said Sony to RCA, "Evil round eye, you are not buying the quantities you said you would." That ended the agreement with RCA. Then "they had the distribution channels, the shipping, and now understood the American market because RCA and Sears had explained it to them, and so they started selling direct." And selling very good stuff.

The stuff got so good in part because Japan in the early 1970s did not have a large vacuum-tube manufacturing base in place, the kind of base the likes of RCA, GE, Zenith, and Westinghouse were reluctant to abandon. So it cost Japan no pain to go for semiconductors. Also, Japan somehow grasped the appeal of the transistor radio. (Said the Board of Directors at Texas Instruments,

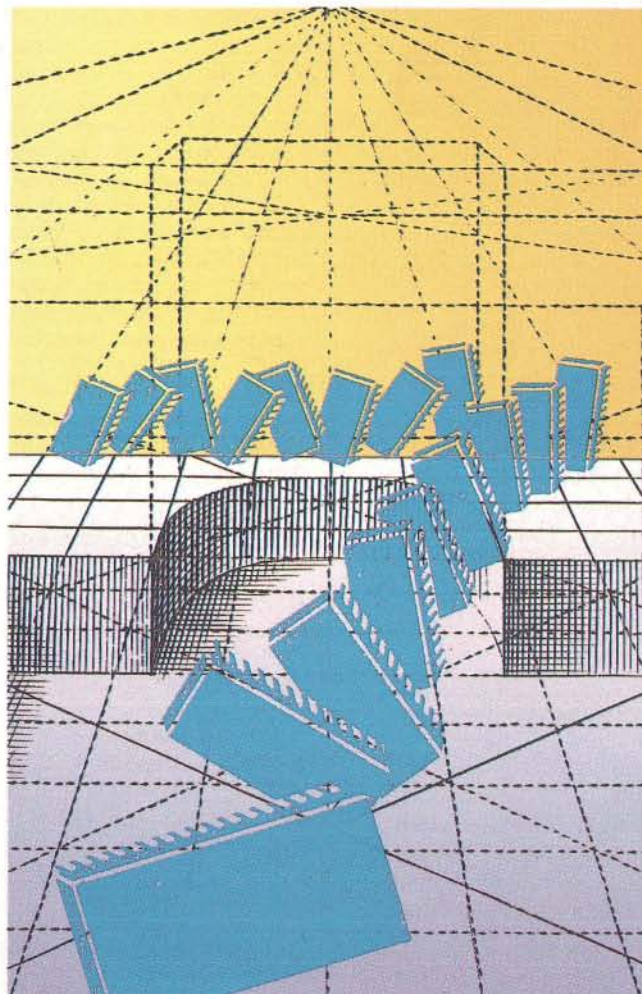

"It's an interesting product, but what value does it have?" TI, Warshofsky correctly remarks, "was not a consumer-oriented company.")

Further nuances: Not only did semiconductors emit less heat and use less power, they reduced the size of the TV.

Then by upping the picture tube's deflection angle from 90 degrees to 110, the Japanese not only decreased the depth of the set (and reduced shipping costs), they made tabletop and portable TVs possible. And, Warshofsky says, "U.S. set manufacturers re-

sponded not by switching to semiconductors but by abandoning the field to the Japanese."

What they planned to abandon was the smaller sets. "Don't go toe to toe," runs a maxim of U.S. business; "you'll just get driven down to a misery gulch of low profits." No, exploit a different niche. So, dropping portables, they went for big consoles; and lo, the popular size of those proved to be 19 inches, which Japan's 110-degree deflection angle had turned into a tabletop. No win. In the U.S., Zenith is the only color TV manufacturer left.

But back to semiconductors, after all a U.S. invention. There the story is fascinating. A place to start is with the DRAM chip, something inherently low-profit. Memory chips are simple, repeating the same pattern over and over. That makes them cheap to manufacture. Memory boards are also simple-minded, the same chip over and over. That increases demand, which (given the economies of quantity production) shoves costs lower still. Pit several competitors against each other (that toe-to-toe competition U.S. business prefers to avoid), and what with their undercutting of one another, you've got a near-zero-profit situation. No one *wants* to be in the DRAM business. Let the Japanese have it, and welcome.

Oh? In 1953, what would become Sony (started in a garage) "licensed the rights to the newly invented Bell Labs transistor for \$25,000. It ranks among the greatest bargains in history." Next, "They seem to be absolute masters at taking this original technology which we invent and improve the hell out of it in such a way that it's better and

continued

ALSO REVIEWED

The Puzzling Adventures of Dr. Ecco

The Mathematical Tourist (Snapshots of Modern Mathematics)

The UNIX Word Processing Book: A Step-by-Step Guide

MS-DOS Developer's Guide

"TURN MY PC INTO A PROTOCOL ANALYZER FOR UNDER \$400?"



If you're involved in data communications, the PC Comscope can give you data line monitor capabilities at a fraction of the cost using your PC. Making use of pull down menu's and built-in help screens provides true operator simplicity. The combination of these features and price make this an extraordinary buy.

You can view the bidirectional data and control signals of any RS-232 link.

The PC Comscope capabilities include:
ASYNC; SYNC; HDLC; TIME STAMPING;
SOPHISTICATED TRAPPING; STORE DATA ON DISK;
ASCII; EBCDIC; IPARS.... Teletype does it again!

PC Comscope for under \$400.

TALK TO **TELETYPE** 270 E. Pulaski Rd. Greenlawn, NY 11740
(516) 423-3232 / 385-8080 or 1-800-835-3298
FAX: (516) 385-8184

it's cheaper. And then they turn around and sell it back to us at a price that is so low it just drives the Americans out of that business."

Confront such mastery with the U.S. itch to get out of the low-profit DRAM business, and you've a formula for disaster. Yes, DRAMs were "jelly beans," boring. But (says one of Warshofsky's sources), "The Japanese learned what Henry Ford learned. When you make enough of anything, you got to get smarter. So the next thing you know, the [Japanese] jelly-bean manufacturers knew more about manufacturing all kinds of semiconductors than the smartasses back in the States." Analogy: Though, true, "The Little Red Hen" is no *Moby Dick*, it does help eager kids to learn.

Doodling with simple DRAMs, the Japanese got the clean-room technology down pat and learned all about automation, operator training, and reliability.

When IBM needed clean rooms for an advanced chip-making plant in East Fishkill, New York, where do you think it went for state-of-the-art construction technology? Why, to a Japanese firm, Shimitzu. IBM's face was saved when an American company named Walsh executed the design (i.e., laid the bricks). Also, IBM claims to have actually enhanced Shimitzu's design with its own "base knowledge." Sure. The company even claims that, really, it had just "wanted to see what they had." Sure. Cool it, IBM.

Meanwhile, buyers like Hewlett-Packard and NCR were observing that those Japanese 16K-bit RAMs had a much lower failure rate than U.S. equivalents. And suddenly (1981), leapfrogging a generation, Japan had 64K-bit RAMs to offer. While raising production to fantastic levels (66 million per year by August 1982), they were simultaneously bringing prices down: from, say, \$30 a chip to \$5. Partly, that was high-volume

throughput. Partly, it was achieved by keeping Tokyo prices high to subsidize lower prices in Palo Alto. But mostly it was ruthless kamikaze pricing, "dumping" to wrest a market share.

By late 1985, Intel, who'd invented the RAM chip, had dropped out of the memory business, and Mostek, once the largest producer of 16K-bit RAM chips in the world, had dropped out of business, period. Motorola and National Semiconductor also gave up on memory. Memory chips were an Oriental monopoly.

A 1986 antidumping agreement did little to help; those high Tokyo prices suddenly became low Tokyo prices, and millions of 64K-bit—later 256K-bit—DRAMs got carried by suitcase from Japan to all over southeast Asia, as well as into the U.S. via Vancouver, where chips enter North America duty-free. You can cram thousands into a duffel bag. One smuggler's method was to bring lots of 40,000 across the border to Washington in a rented car, airfreight them to California, and then cover his tracks by driving back to Vancouver and boarding a plane to his home base in California. There, he could sign for the luggage he'd airfreighted. After that, bingo! A market thirsted for chips.

By spring 1987, sanctions were in place against Japan for noncompliance with the anti-dumping agreement. But it was too late for the U.S. chip manufacturers, most of whom had quit. The chief effect of the sanctions was to start U.S. equipment manufacturers yelling because their component costs were shooting up. (They stay up still.)

"It is time to restore the American work ethic": That's about the essence of Warshofsky's findings. "We must compete with people who display remarkable traits—loyalty, pride, and desire." These people include not only the Japanese, but the "Little Dragons" (Taiwan, Hong

continued

Compact Disk Products, Inc. CD-ROM/WORM

ALL PRODUCTS, LOWEST PRICES, EXPERT ADVICE

INTRODUCTORY OFFERS

Hitachi 1503S or 3500S CD-ROM Drive with your choice of:

- NEW Programmer's Reference Library (Microsoft) . . . \$995
- McGraw Hill Science and Technical Reference Set . . . \$320
- Grolier Electronic Encyclopedia . . . \$995
- Microsoft Bookshelf or PC-SIG Library (Add \$200) . . . \$895

SELECT CD-ROM SOFTWARE

- Oxford English Dictionary **NEW** \$945
- Comstock Stock Photography On CD . . . **NEW** \$445
- Educorp Public Domain/Shareware for the Mac . . . **NEW** \$179
- The New Grolier Electronic Encyclopedia . . . \$359
- McGraw Hill or Bookshelf (Add \$25 for McGraw) . . . \$269
- The Bible Library \$495
- Kirk-Othmer Encyclopedia of Chemical Technology . . . \$845
- Registry of Mass Spectral Data \$2655
- Geovision U.S. Atlas and Mapmaker \$795

TOLL FREE ORDER LINE • 800-MEGABYTE (634-2298)

CD-ROM and WORM DRIVES

- Hitachi 1503S External CD-ROM Drive with Audio \$729
- 1503S with Digital Audio Output and CD-Capture . . . \$1229
- Hitachi 3500S Internal 1/2 Height CD-ROM Drive w/Audio . . \$719
- NEC Intersect CD-ROM Drives for the Apple/Mac CALL
- Maxtor 800 MB WORM Drive \$3899
- Portable 286 with CD-ROM Drive and Hard Disk CALL

CD-Play (\$89) Pop-up utility that permits user to play all audio CDs on Hitachi and compatible drives. Output to headphones or amplifier.

CD-AudioFile (\$149) Automatically creates database records of all your audio CDs. Allows you to store a preferred play sequence for each disk. Automatic recognition of CDs. Creates DBase compatible records.

CDP

Consulting Services Now Available

Compact Disk Products
223 E. 85th St.
New York, NY 10028
Tel. 212-737-8400
Tel. 212-737-8289
Fax 212-737-8289
CompuServe 75530214

INTERNATIONAL ORDERS A SPECIALTY

International Agents:
United Kingdom
CDROM - New Manor Farm
Winterslow Near Salisbury
WILS SP5 4SE
Tel. 0980-862890

Australia
Kewtel
145 Cotham Road
Kew, Victoria 3101
Tel. 03-917-5933

Australia
Light Years Ahead
PO Box 567
Wahroona, NSW 2078
Tel. 02-477-8666



BLINDING SPEED
COMPLETE COMPATIBILITY

Introducing the high speed modems from U.S. Robotics

Until now, high speed modem users had the best of one world. They either had speed or compatibility. U.S. Robotics just changed all that.

THE BEST OF ALL WORLDS...

With the new line of high speed modems from U.S. Robotics — the Courier HST, the Courier HST Dual Standard and the Courier V. 32 — you can now have both the highest speeds and the most compatibility.

For speed — it's the Courier HST which delivers throughput over 24,000 bits per second with MNP® level 1-5 error control and compression. And it still costs less than \$1,000.

For Compatibility — the Courier V.32 provides CCITT standard modulations from 300 bps to 9600 bps for under \$1,495. And with MNP levels 1-5 you will get complete data integrity plus throughputs approaching 19,200 bps.

For the best of all worlds — it's the Courier HST Dual Standard, combining the blinding speed of the Courier HST with the compatibility of the V. 32. At \$1,595, it costs less than some featureless V. 32-only modems.

U.S. ROBOTICS — THE EXPERT'S CHOICE

You would expect the broadest high speed modem line from U.S. Robotics. We manufactured our first HST in 1987, and it quickly became the standard on over 5,000 bulletin boards and over 40,000 users. Rated #1 by *Data Communications* magazine, it confirmed what our customers knew all along — U.S. Robotics delivers the best modem value. And we've been doing that for 13 years — for almost 1,000,000 customers.

When you look for high speed modems, don't settle for half a solution. Look to U.S. Robotics. Call today for details on the high speed modems that give you the best of all worlds.

Call 1-800-Dial USR. (1-800-342-5877)
or (312) 982-5001 in Illinois

U.S. Robotics®

The Intelligent Choice in Data Communications

8100 North McCormick Boulevard, Skokie, Illinois 60076
U.S. Robotics, Courier and HST are trademarks of U.S. Robotics, Inc. Other computer and software names identified by ® or ™ are trademarks of their respective manufacturers. Prices are suggested retail prices in U.S. Dollars.
For sales in the United Kingdom, please call Miracom, Ltd., Ipswich, England.
Telephone: 0473 233888. For Canadian sales, call 1-800-553-3560.

PROTECT INTELLIGENCE WITH INTELLIGENCE

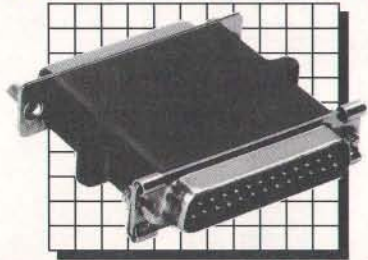

SOFTWARE PROTECTION KEYS BY PROTECH

PROTECH KEYS:

- are totally transparent to the end user
- allow unlimited back up copies
- free up disk drives
- do not interfere with peripheral operations
- are easy to install
- protect software developers' revenues
- assembler based routines (not drivers)
- encrypted routines
- physically unique hardware KEYS
- sophisticated software installation advice
- provide the highest level of protection available

THE KEY

The KEY provides effective software protection while insuring customer satisfaction. The KEY is a random response device which is designed for identically reproduced software packages.

THE MEMORY KEY

The MEMORY KEY is a programmable software protection device. Each byte of memory can be addressed in groups or individually. Possible applications for the MEMORY KEY include:

- modular package control
- serialization
- customization
- access control to PCs
- demo control
- software leasing
- updating modules in the field
- any "counter" operation

For a demonstration package or additional information, please write or call:

1-800-843-0413

PROTECH MARKETING, INC.
4905 Pine Cone Drive • Building 10
Durham, North Carolina 27707
(919) 490-4970 FAX (919) 490-4974

WE HAVE THE KEY TO SOFTWARE COPY PROTECTION

Complete 386 Compiler Package for \$895

SVS FORTRAN-386

- Runs in 32-bit Protected Mode
- Accesses all Available Memory
- Supports VAX and IBM Extensions
- Supports the Intel 287/387 and Witek 1167/3167 Co-processors
- Applications run up to four times faster than those created with other compilers
- Compiles at High Speed

Package Includes:

- SVS FORTRAN Compiler
- LINK-REX Linker
- 100% Royalty Free License on Distributed Software
- DOS Extender
- DOS Support Library
- Librarian
- Debugger
- Technical Support



"The SVS compiling and linking is extremely fast, and the compiler produces nicely compact code." - *Micro/Systems Journal*

"The LOADS module in DOE-2 is about 14,000 lines of code. I used SVS FORTRAN-386 since it was the only compiler that would swallow the source code (VAX extensions)." - *Programmer's Journal*

Software Conversion Services are also available for converting FORTRAN mainframe source code to the 80386. This service includes conversion, code optimization, user I/O, and more. Call SAIC for more information.

SAIC
Science Applications
International Corporation
5150 El Camino Real, Suite C-31
Los Altos, California 94022

PRICES:
SVS FORTRAN-386.....\$895
SVS PASCAL-386.....\$895
Scitech Scientific Library.....\$325
Scitech Plotting Library.....\$325
Maintainability Analysis Tool....\$895

For More Information Call: **1-800-346-5159** In CA Call: (415) 960-5931

Kong, Singapore, and South Korea) and even the Europeans. In Korea, the road-cleaning crews have no supervisors. Even so, "they're always sweeping something, picking up something." Compulsively sweeping, picking up—that verges on slapstick. Yet Warshofsky is persuasive: A like sense of communal purpose propels populations who have become our adversaries in the Chip War.

A shiny and compact machine in my kitchen, micro-processor-governed, accepts dry ingredients and wet, then 4 hours and 40 minutes after the push of one button, it delivers a loaf of premium-quality bread. It kneads dough with a look of purpose, pauses for fermentation, kneads again, waits again, detaches the kneading paddle, hunkers down for a long but precisely timed ferment, bakes, and cools. You can watch all this happen through a plastic dome, like R2D2's cranium. Baking temperature gets diligently contoured to local ambience amid a chorus of chirps and clicks. That processor was obviously custom-made. No combination of housewife and home oven is likely to match its finesse. The shipping carton says "Japan." I fear I have seen the future, and it chirps.

BRIEFLY NOTED

The Puzzling Adventures of Dr. Ecco by Dennis Shasha, W. H. Freeman and Co., New York: 1988, 182 pages, \$9.95. I first heard of Dr. Jacob Ecco when I was a college senior majoring in mathematics. At the age of 19, he had earned his Ph.D. at Harvard with a thesis on combinatorial catastrophe theory, then all but vanished into New York's Greenwich Village. A professor of mine had known Ecco in Cambridge and remembered him as a problem solver of incredible intellect. But Ecco also has, apparently, a great ability to rub people the wrong way—which may account for his

turning his back on an academic career (though he was offered an endowed chair in mathematics at the University of Wisconsin at the unheard-of age of 20).

After dropping out of academia, Ecco went into business, calling himself an "omniheurist," someone who solves all problems. He eventually built up a clientele that now includes heads of state, various government agencies, and business tycoons—anyone having a difficult puzzle to solve (and the wherewithal to afford Ecco's ever-increasing fee). This business has been so successful that Ecco can afford to spend most of his time on a pet project: trying to figure out the puzzle of the human brain.

Although rumors of the sheer brilliance of Ecco's puzzle-solving feats have been floating around, almost all his successes have been shrouded in secrecy. Ecco himself is too publicity-shy to permit interviews, and he rigorously protects his clients' privacy. Thus, it is a major feat that Dennis Shasha, a computer scientist at the Courant Institute of Mathematical Sciences in New York, was able to coax Ecco into revealing not only the most challenging puzzles of his career, but also a glimpse into the workings of his amazing mind.

Narrated by Shasha's colleague, Professor Scarlet, the stories of Ecco's puzzling cases are told in a way very much reminiscent of Dr. Watson's chronicling of the adventures of Sherlock Holmes.

Although the names of Ecco's clients have been changed for obvious reasons, we can infer the identity of some: "Code Breaking" (the National Security Agency?), "Circuits Checking Circuits" (IBM?), and "Spies and Double Agents" (I'll leave that one to you). In all, the details of 38 of Ecco's most difficult problems are presented.

To give us a fair chance to compete with Ecco, we are

continued

Automation For The 90's From The Heartland

CORPORATE COMPUTERS OF IOWA provides the nation's most aggressive prices on all TOSHIBA®, EPSON®, NEC® and PANASONIC® printers, FAX machines, laptops and cellular phones.

Call one of our account executives today and experience the performance and quality you'd expect from the "Heartland."



CORPORATE COMPUTERS OF IOWA 386 PERFORMANCE AT THE NATIONS LOWEST 286 PRICING!!!

CCI AT 286/20 MHZ

80286 Processor Running At 20/10	14" Multisynch Monitor
Phoenix Bios/Digital Speed Display	EVGA Graphics Card
80287 Math Co-Processor Socket	1 - Parallel - 2 Serial - Game Port
8 Expansion Slots	101 Key AT Keyboard w/Dust Cover
1 Meg RAM	DOS 4.01 w/GW Basic Surge Suppressor
(Expandable to 8 Megs)	1 Year Parts and Labor Warranty
1.2 Meg Floppy	30 Day Money Back Guarantee
1.44 Meg Floppy	2nd Year Warranty \$49.95
80 Meg Seagate ST-4096 (28MS)	
WD Controller	

**CORPORATE COMPUTERS OF IOWA PRICE
\$2,799.00**

1 Year On Site Service Contract \$79.00
Corporate Computers of Iowa Policies

- Toll Free Number 1-800-533-0948 For Ordering And Post-Sale Support
- Master Card, VISA, And American Express Accepted - Add 3%
- C.O.D. Cashier Checks
- 30 Day, Money Back Guarantee With 10% Restock Fee
- Prices Subject To Change In Manufacturers Pricing
- Allow 10 Days For Personal Checks To Clear
- Call For Corporate Purchase Orders
- Dealer Inquiries Invited

1-800-533-0948

TOSHIBA LAPTOPS

MODEL	RETAIL	CCI PRICE
T-1000	\$1249.00	\$ 760.00
T-1200F	\$2099.00	\$1299.00
T-1200FB	\$2399.00	\$1485.00
T-1200H	\$3499.00	\$2159.00
T-1200HB	\$3699.00	\$2275.00
T-1600	\$4999.00	\$3000.00
T-3100E	\$4299.00	\$2599.00
T-5100	\$7199.00	\$4300.00
T-5200	\$9499.00	\$5700.00

FREE box of 3.5 Diskettes with every Toshiba

EPSON PRINTERS

MODEL	RETAIL	CCI PRICE
LX-800	\$ 299.00	\$167.00
FX-850	\$ 549.00	\$339.00
FX-1050	\$ 799.00	\$449.00
LQ-500	\$ 529.00	\$299.00
LQ-850	\$ 859.00	\$519.00
LQ-950	\$ 949.00	\$589.00
LQ-1050	\$1199.00	\$699.00
LQ-2550	\$1499.00	\$925.00

Corporate Computers of Iowa offers a "FREE" 6 foot cable with every Epson Printer Purchased!!

CCI STATE OF THE ART COMMUNICATIONS PRODUCTS

MODEL	RETAIL	CCI PRICE
Cobra Porta Fax	\$1295.00	\$ 875.00
GE XR 3500 Cellular Phone	\$ 795.00	\$ 625.00
NEC M3700 ES Cellular Phone	\$ 895.00	\$ 649.00
Mitsubishi Model 800 Transportable	\$1495.00	\$ 975.00
Mobira P-30 Hand Held Phone	\$1395.00	\$ 935.00
NEC 9100 Hand Held Phone	\$1495.00	\$1110.00
Panasonic UF-150 Fax	\$1795.00	\$ 980.00
Panasonic UF-260 Fax	\$2795.00	\$1499.00

**386 25MHz
Tower
\$3399.00**

**286 12 MHz
CALL FOR PRICING**



CORPORATE COMPUTERS OF IOWA

P.O. Box 714
Sioux City, Iowa 51102
712/277-2100
Toll Free: 1-800-533-0948
Corporate Showroom
609 5th Street
Sioux City, Iowa 51101

Circle 75 on Reader Service Card (DEALERS: 76)

Microstat-II Now With Graphics
Interface and New Multivariate Module

2.0
Release

Now you can use YOUR favorite graphics package with Microstat-II.

Just some of the packages covered include *3-D Perspective Jr.*, *Harvard Graphics*, *Microsoft's Chart*, *Grapher*, and others.

Microstat-II also includes new procedures for:

- Canonical Correlation
- Factor Analysis
- MANOVA
- Discriminant Analysis
- Principal Components Analysis
- Cluster Analysis
- Covariance Analysis

While Release 1.0 was good:

"... one of the fastest IBM PC statistical packages we have tested... using Microstat-II is a breeze."

Infoworld

"Installation of Microstat-II is simple... The user interface is clean... a pleasant package to use..."

PC Magazine

Microstat-II Release 2.0 is even better!

For a limited time, you can purchase Microstat-II Release 2.0 for \$395.00. Microstat-II requires an IBM PC, XT, AT, PS2 or compatible with 512K memory or more with either a hard disk or two floppy drives. For more information, contact your local computer dealer or call:

Ecosoft, Inc.

6413 N. College Ave.
Indianapolis, IN 46220
Orders: 1-800-952-0472
Info: 1-317-255-6476
FAX: 1-317-251-4604



ECOSOFT



3-D Perspective Jr.

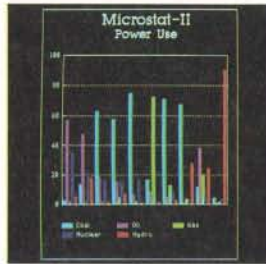

Harvard Graphics

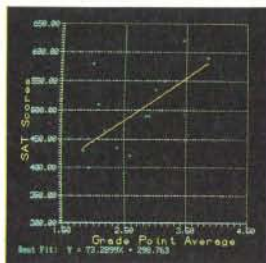

Grapher

3-D Perspective Jr., Harvard Graphics, Grapher, Microsoft's Chart and IBM are all registered or unregistered trademarks of the following companies respectively: 3-D Graphics, Inc., Software Publishing Corp., Golden Software Inc., Microsoft Inc., IBM Inc.

asked questions at various points that will, if correctly answered, lead us to the solution.

The Puzzling Adventures of Dr. Ecco is written in a conversational style that makes it a pleasure to read. Ecco's cases are tough, though; I don't think many people could make a living trying to solve them. The aspect of this book that I find most appealing is that Shasha, Scarlet, and Ecco have chosen problems that face many of us (in different guises) in the day-to-day affairs of computing, science, and business. Paying close attention to the puzzle-solving techniques of a master like Ecco just might make our own professional problems a little bit easier to handle.

—Eric Bobinsky

The Mathematical Tourist (Snapshots of Modern Mathematics) by Ivars Peterson, *W. H. Freeman and Co.*, New York: 1988, 240 pages, \$17.95. During the twilight of Queen Victoria's reign, it was fashionable for English gentry to pass their idle hours studying mathematics. Some of these amateur mathematicians were amateur only in that they weren't paid for their skills; they contributed not a little to the science of mathematics. Nowadays, we'd be surprised if someone told us they "did mathematics" as a hobby. The entire dry, dusty field has been relegated to the ivory towers—and rightly so, since it never changes; all the mathematics we'll ever need was invented 200 years ago, and there's no reason to subject us to any more of it than we had to take in school. Right?

Actually, mathematics is anything but dry and changeless. It is as fluid as art and as variable as the seasons, and it can be as new and fresh as good literature. Mathematics today is undergoing nothing short of a renaissance, thanks in part to the computer and in part to the warm reception nonmathematicians have been giving esoteric concepts like

fractal geometry, chaos, and curved space-time. Today, apparently, there is a general desire for heightened mathematical awareness.

Ivars Peterson, a science teacher and science writer, satisfies that desire by surveying the landscape of modern mathematics: from the first use of a computer to prove a theorem to the (still) mysterious world of prime numbers; from soap bubble surfaces and knots to fractal mountains; from modern cryptology to mathematical monsters; from the uncertainty of chaos to the computer game of Life; and other fascinating topics.

Peterson takes us to the heart of modern mathematics. Using words we can understand, he reveals the excitement of discovery and the allure of the unknown that characterize mathematical research today. With its clear, conversational tone and excellent illustrations, *The Mathematical Tourist* is a landmark book about a field whose rare beauty is far too often hidden from view.—Eric Bobinsky

The UNIX Word Processing Book: A Step-by-Step Guide by Bryan Strong and Jay Hosler, *John Wiley & Sons*, New York: 1988, 380 pages, \$24.95. This attractive plastic-comb-bound book makes a handy companion beside your Unix terminal. It includes two tear-out reference cards: one on Unix commands and utilities, and the other on specifics of the standard Unix text-editing and formatting programs. The pages are comfortably designed, with wide margins for notes. Two-color printing emphasizes sections, and visual relief is provided with homey illustrations of cats and computers.

Each unit is divided into a section that introduces the concepts mixed with "Hands-On Activities," followed by a review of the material. Strong and Hosler also provide countless examples, exercises, and summaries. This is atypical of

continued

MODEL	DESCRIPTION	RESOLUTION			RS-170	Zoom, Pan,	MEMORY	MEMORY	MEMORY	Zoom, Pan,	NiM Conv.,	Real-Time Frame Aver. Math & Logic	Hardware Window
		Spatial	Gray Levels	Number									
DT2862-60Hz ^a DT2862-50Hz ^a	Arithmetic Frame Grabber	512 x 512	256	8 ¹							8-bit	✓	
DT2862-60Hz ^a w/ DT2858 ^a	Frame Grabber & Frame Processor	512 x 512	256	8 ¹							8-bit or 16-bit ²	✓ ^a	
DT2862-50Hz ^a w/ DT2858 ^a	Frame Grabber & Frame Processor	512 x 512	256	8 ¹							8-bit or 16-bit ²	✓ ^a	
DT2861-60Hz ^a DT2861-50Hz ^a	Arithmetic Frame Grabber	512x512	256	8 ¹							8-bit or 16-bit ²	✓	
DT2861-60Hz ^a w/ DT2858 ^a	Frame Grabber & Frame Processor	512x512	256	8 ¹							8-bit or 16-bit ²	✓	
DT2861-50Hz ^a w/ DT2858 ^a	Frame Grabber & Frame Processor	512x512	256	8 ¹							4-bit		
DT2851-60Hz ^a DT2851-50Hz ^a	High Resolution Frame Grabber	512 x 512	256	8 ¹							4-bit or 16-bit ²	✓	
DT2851-60Hz ^a w/ DT2858 ^a	Frame Grabber & Frame Processor	512 x 512	256	8 ¹							4-bit or 16-bit ²	✓	
DT2851-50Hz ^a w/ DT2858 ^a	Frame Grabber & Frame Processor	512 x 512	256	8 ¹							4-bit		
DT2853-60Hz ^a DT2853-50Hz ^a	Low Cost Frame Grabber	512 x 512	256	8 ¹							4-bit		
DT2853-SQ-60Hz ^a DT2853-SQ-50Hz ^a	Low Cost, Square Pixel Frame Grabber	512 x 512	256	8 ¹									
DT2803-60Hz DT2803-50Hz	Low Cost Frame Grabber	256 x 256	64	8 ¹									



-Fred Molinari, President

Think of it as a Frame Grabber that's big on versatility and small on cost.

The DT2853 all-purpose frame grabber.

This \$1,795 frame grabber board contains all the basic essentials for image processing. Real-time capture and display with 512 x 512 resolution and 256 gray levels. Two onboard buffers. Onboard look-up tables. There's even an optional square pixel version available.

There's also a broad range of software available to support the DT2853 for specific applications, ranging from microscopy to modeling, to motion analysis and more. IRISutor™ Image Processing

Software is shipped FREE with the board.

Think of the DT2853 as a multi-purpose tool for real-time digital image processing on the IBM® PC AT®. Because it is.

You should also know that the DT2853 frame grabber wins the price/performance comparison every time. Because it gives you more features and options for less cost.

Call (508) 481-3700
In Canada, call (800) 268-0427

FREE 1989 Image Processing Handbook.



OVER DELIVERY NIGHT

DATA TRANSLATION®

World Headquarters: Data Translation Inc., 100 Locke Drive, Marlboro MA 01752-1192 USA, (508) 481-3700 Tlx 951646
 United Kingdom Headquarters: Data Translation Ltd., The Mulberry Business Park, Wokingham, Berkshire RG11 2QJ, U.K. (0734) 793838 Tlx 94011914
 West Germany Headquarters: Data Translation GmbH, Stuttgarter Strasse 66, 7120 Bietigheim-Bissingen, West Germany 01742-54025
 International Sales Offices: Australia (2) 662-4255; Belgium (2) 466-8199; Canada (416) 625-1907; China (1) 868-721 x4017, (408) 727-8222; Denmark (2) 274511; Finland (0) 372144; France (1) 69077802; Greece (1) 951-4944, (31) 527.039 (1) 361-4300; Hong Kong (5) 448963; India (22) 23-1040; Israel (3) 5401524; Italy (2) 82470.1; Japan (3) 502-5550, (3) 348-8301, (3) 355-1111; Korea (2) 756-9954; Netherlands (70) 99 6360; New Zealand (64) 9-545313; Norway (2) 53 12 50; Portugal (1) 545313; Singapore (65) 7797621; South Africa (02) 8037680/93; Spain (1) 455-8112; Sweden (8) 761-7820; Switzerland (0) 723-1410; Taiwan (2) 7020405

IRISutor is a trademark and Data Translation is a registered trademark of Data Translation, Inc. All other trademarks are the property of their respective holders.

Introducing the Smallest 80386 based PC Compatible Single Board Computer Only 4" x 6"



Quark/PC® II

- VGA® VidedColor LCD Controller
- SCSI Hard Disk Control
- Up to 4 Mbytes Memory and more

To order or enquire call us today.

Megatel Computer Corporation
(416) 745-7214 FAX (416) 745-8792

174 Turbine Drive, Weston, Ontario M9L 2S2

Distributors

Germany — Tech Team (06074) 98031 FAX (06074) 90248

Italy & Southern Europe — NCS Italia (0331) 256-524 FAX (0331) 256-018

U.K. — Densitron (0959) 76331 FAX (0959) 71017

Australia — Asp Microcomputers (03) 500-0628 FAX (03) 500-9461

Denmark — Ingeniorfirmaef (02) 440488 FAX (02) 440745

Finland — Digipoint (3580) 757 1741 FAX (3580) 757 0844

Norway — AD Elektronik (09) 877410 FAX (09) 875990

Sweden — (040) 97 10 90 FAX (040) 13 90 38

Quark is a registered U.S. trademark of F. & K. MFG. Co. Ltd. VGA is a registered trademark of IBM Corp.

megatel

BOOK REVIEWS

Unix books. The material is an unusual mixture of relatively advanced Unix text-formatting concepts and very elementary Unix commands and shell concepts. The writing style is appropriate for the nontechnical—perhaps even neophyte—Unix user, but it seems at odds with the material.

The first unit introduces *troff*. The second unit covers Unix shell concepts, including redirected I/O and pipes, background processes, and shell scripts. The third unit introduces the concepts of type-setting and *troff*. Not until the fourth unit (page 184) are you given any information about the standard editor, *vi*. And then the text starts at the very basic level of moving the cursor.

The final section gives instruction in a miscellany of Unix commands, including *spell*, *lpstat*, *find*, *grep*, and *diff*. The three appendices are very worthy guides for any Unix user, as is the glossary.

It seems a shame to have put so much planning into the publication of this book and to have its material miss the needs of the modern Unix user. The target audience seems to be the poor soul who isn't adept at Unix and yet is required to use the old standard Unix tools to turn out documents.

These tools are far from what is considered "word processing" in the more common world of personal computers and word processing machines. I prefer to use *vi* over any true word processing program that runs under Unix. However, I am a programmer at heart and like the Spartan world of text editors over the elegant world of WYSIWYG word processing. This book was certainly *not* written for programmers.—*Ben Smith*

MS-DOS Developer's Guide, 2nd ed. by the Waite Group, Howard W. Sams & Company, Indianapolis, IN: 1988, 783 pages, \$24.95. This delightful

book is best viewed as an anthology of loosely related topics for developers of MS-DOS software.

The introductory chapters deal with structured and modular design of assembly language programs. TSR programming is given a detailed treatment, including descriptions of privileged DOS calls and internal DOS structures, many of which have never appeared in print. Two chapters on the LIM/EMS are perhaps as clear and thorough explanations of this topic as have been published to date.

Other sections present programming of real-time applications, using a serial port, the basics of EGA/VGA register programming, and the Intel 8087 math coprocessor. There are discussions of disk layout and file recovery and the differences among DOS versions through 4.0. A useful appendix tabulates MS-DOS interrupts and functions that are not publicly documented by Microsoft, with calling sequences. Finally, there is a sturdy tear-out MS-DOS reference card that summarizes the various DOS interrupts and functions.

For a large book with multiple contributors, this has remarkably few inconsistencies and typos. It is chock full of useful examples written in assembly language and C. Because it fills in many gaps in Microsoft's *MS-DOS Encyclopedia*, the *MS-DOS Developer's Guide* is a must reference book for designers of TSR programs, device drivers, and EMS applications.

—*Ben Myers* ■

CONTRIBUTORS

Critic and author **Hugh Kenner** lives in Baltimore, Maryland. **Eric Bobinsky** works at the NASA Lewis Research Center in Cleveland, Ohio. **Ben Smith** is a BYTE technical editor. **Ben Myers** is the designer of Personal Measure, a PC performance measurement package, and lives in Harvard, Massachusetts.

MATHPAK 87

High Performance 80x87 Software

Over 130 assembler coded routines which are designed to take full advantage of 80x87 math coprocessors.

Designed for Speed

Up to 20 X faster than high level language!

1 K complex FFT on a 386/20 takes 0.28s; real 0.17s (1.85s & 1.0s on an IBM XT); dot product (length 10,000) in 0.07s (0.49s on XT).

MATHPAK 87 provides you with the fastest, most convenient and comprehensive set of tools available.

MATHPAK 87 includes: 65 vector/scalar routines; 24 complex vector/scalar routines; 11 matrix utility routines (add, subtract, multiply, transpose, ...); LU decomposition/back-solving routines for real & complex systems; gaussian elimination; matrix inversion, tridiagonal equation solver routines; EISPACK type eigenvalue/vector routines; statistical routines; FFTs (1-D, 2-D, complex, real, convolution); spectral analysis routines (windows: Parzen, Hamming, ...); routines for numerical integration & solution of differential equations; and missing functions for Modula-2 and Pascal: tan, log10, alog10, power, sinh, cosh, & tanh; and more.

Widely used in signal & image processing, simulation, spectral analysis, etc.

Users like MATHPAK 87 & take the time to tell us!

Order Today!

Precision Plus Software
1239 Sir David Drive
Oakville, Ontario
Canada L6J 6Y9
Tel: 416-829-1511
Fax: 416-829-1742

\$99US for Turbo Pascal version. \$119US for Fortran (MS, IBM Prof. or F77L), C (MS, Turbo or Lattice), and Modula-2 (Logitech or ITC) versions. Add \$69US for complete source code. Add \$5 for shipping. Specify compiler.

International Dealer: SOS Software Service, GmbH, Alter Postweg 101, 8900 Augsburg, West Germany, Tel: 0821/57 1081, Fax: 0821/57 7659.

Timings (COMPAQ 286, 12MHz)
Execution Time for 100,000 Operations

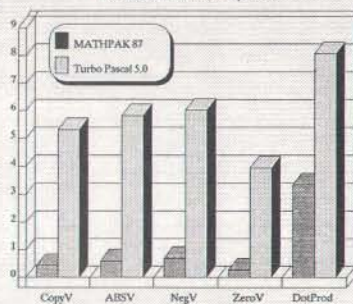

NEW MAPINFO 4.0: DESKTOP MAPPING ON A NETWORK

MapInfo's new version of their desktop mapping software offers full multi-user functionality.

MapInfo Corp., which gave us the first true high end, low cost desktop mapping package in 1987 and the world's first desktop mapping programming language in 1988, is adding a new dimension to this market with the introduction of MapInfo 4.0.

The new version, which is already shipping, is the first desktop mapping package on the market that comes network ready. This represents a major breakthrough for the desktop mapping market because it opens the door for the sharing of the large data files and peripherals typically associated with desktop mapping products.

In a nutshell, MapInfo allows you to use computer maps to get more meaning and knowledge out of databases — particularly if they have some type of locational field, such as a street name and number, city, ZIP code, county or state.

The powerful MapInfo engine actually operates directly with your dBASE (compatible or ASCII) files and lets them interact



Common Files MapInfo 4.0 allows many users to share street maps like this one — which come with every address accurate to the correct block and side of street — and maintain their own separate overlays.

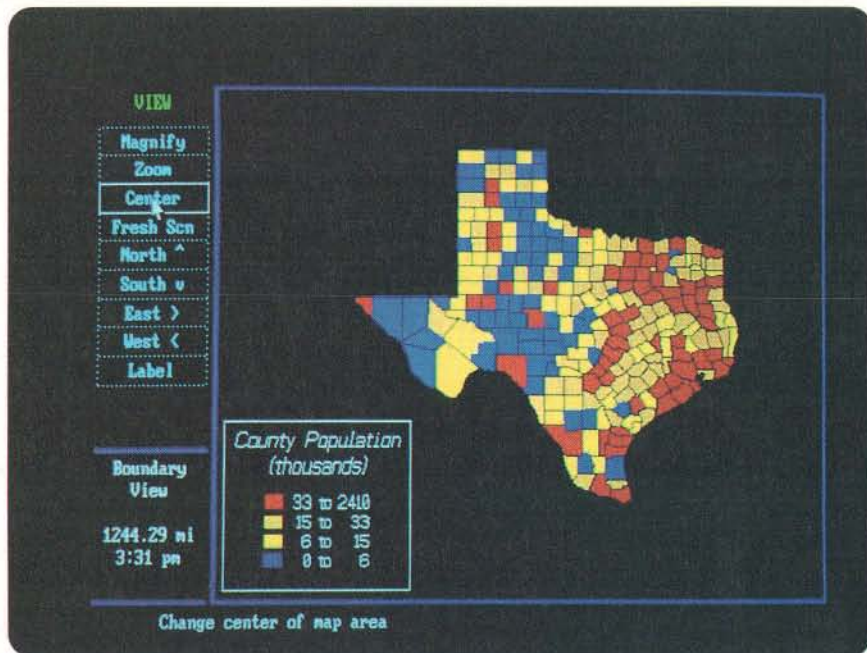

Shared Database Information Merged With Maps MapInfo 4.0 is the only desktop mapping package that will run on a network, allowing many users to overlay separate database information on a shared map.

with an incredible range of maps, including street maps for most metropolitan areas, county, ZIP code, state maps, and so forth, available separately from MapInfo Corp.

Now, with MapInfo 4.0 running on your network, you can share your computer maps, or databases with other people in your organization. This capability will soon become a *must* for every desktop mapping package, considering the large size of typical databases, the work group nature of mapping analysis, and the expense of certain optional output devices used in some desktop mapping applications.

For example, a single organization with multiple MapInfo users running on a Novell network could simultaneously access a computer map of Manhattan; each perhaps using a common demographic file, while maintaining their own custom-drawn boundary overlays (file locking prevents simultaneous edits). Users could also share a low cost printer for quick black and white maps, and

a pen plotter for larger, color work.

As if connectivity were not enough, MapInfo has also packed into version 4.0 an array of impressive enhancements, like:

- the ability to play "what-if" with your data without leaving MapInfo,
- the ability to create custom symbols to display your data,

"Networking will soon become a *must* for every desktop mapping package..."

- an extended character set for foreign language applications,
- a useful edit log file that protects edit changes in case of power loss.

That's just a small sampling. MapInfo Corp. has set up a toll-free hot line to answer questions about mapping on your network. Write to MapInfo at 200 Broadway, Troy, NY 12180, or call 518-274-8673, or 1-800-FASTMAP toll free.

Unbeatable Selection 1-800-445-7899

This Month's Specials from Lattice

	LIST OURS
Lattice C Compiler 3.4	450 249
Lattice (C) Amiga Compiler	300 199
Lattice Comm. Library	250 189
Curses	100 59
dBC III	250 179
dBC III Plus	500 349
RPG 3.0	1600 1279
SecretDisk II	79 59
SideTalk	120 99
SSP/PC	350 279

LIST OURS

PROTOTYPING

Dan Bricklin's Demo Program II	195 179
Grasp 3.5	199 169
Instant Replay III	150 131
Proteus	149 125
Show Partner F/X	350 319

REFERENCE GUIDES

Command Tips	90 80
Norton Guides	100 75
Tom Rettig's HELP	120 105

SORT UTILITIES

AutoSort	150 131
MS Sort	195 130
Opt-Tech Sort	149 105
Sortex	150 129

TRANSLATORS

Bas_C (Commercial)	375 323
Bas_Pas (Commercial)	280 242
BASTOC	495 399
dBx TRANSLATOR	550 469
PROMULA.FORTRAN	450 425
TP2C	249 199

UTILITIES

1 DIR Plus	95 75
BACK-IT	129 120
Command Plus	80 70
w/Programmer's Toolkit	130 115
Copy II PC	40 35
Copy II PC Option Board	159 139
Disk Technician Advanced	190 159
Disk Technician Plus	130 119
FASTBACK Plus	189 142
HELP ME	99 90
hTest:hFormat	90 80
MACE GOLD	149 129
MACE Utilities	99 90
Magellan	139 CALL
MKS Toolkit	199 169
Norton Commander	89 56
Norton Utilities	100 61
Norton Utilities Advanced	150 101
Pathfinder	70 65
PC Fullback	70 59
PC/Tools Deluxe	80 70
V OPT	50 47
Vformat Deluxe	120 111
Vtools	50 47
XENOCOPY-PC	80 70
XTree	70 60
XTree Pro	129 111

VERSION CONTROL SYS.

MKS RCS	189 161
PVCS (Corporate)	395 332
PVCS (Personal)	149 131
Seidl Version Manager	300 269
TLIB	100 90

OTHER LANGUAGES

APL+PLUS PC	695 529
C-terp	298 219
Janus/Ada C Pak	129 115
muLISP-87 Interpreter	300 219
PC Scheme	95 79
PC/FORTH +	250 225
Personal Rexx	150 129
Turbo Prolog	150 112

XENIX/UNIX SOFTWARE

Aspen Korn Shell	125 109
Basmark QuickBASIC (386)	695 629
db_FILE	CALL CALL
DOS-alike	89 79
EDIX	275 222
Epsilon	195 152
Informix Products	CALL CALL
Micro Focus COBOL/2 (386)	3500 2995
Microport Sys. V/386 (comp.)	899 759
Microport Sys. V/AT (comp.)	649 549
Microsoft FORTRAN	695 CALL
Microsoft Pascal	695 CALL

LIST OURS	
MKS Trilogy	119 105
PANEL PLUS	795 675
SCO 386 XENIX Sys. V (comp.)	1495 1195
SCO XENIX System V (comp.)	1295 999

BORLAND

Paradox 3.0	725 525
Sidekick Plus	200 149
Turbo Assembler/Debugger	150 112
Turbo Basic	100 75
Turbo C 2.0	150 112
Turbo C 2.0 Professional	250 175
Turbo Pascal 5.0	150 112
Turbo Pascal 5.0 Professional	250 175
Turbo Prolog	150 112
Turbo Prolog Toolbox	100 75

GREENLEAF

Greenleaf Bus. MathLib, DOS	325 229
Greenleaf Comm. Library	229 165
Greenleaf DataMath Interface	75 69
Greenleaf DataWindows, DOS	295 219
Greenleaf Functions	209 155
Greenleaf MakeForm, DOS	125 99
Greenleaf SuperFunctions	265 189
Greenleaf ViewComm	495 449

IGC

VM/386	245 205
VM/386 Multi-User	895 759
VM/386 NetPak	150 129

MICROSOFT

MS BASIC/6.0	295 199
MS C	450 299
MS COBOL	900 599
MS Excel	495 299
MS FORTRAN	450 299
MS Macro Assembler	150 99
MS OS/2 Programmer's Toolkit	350 229
MS Pascal	300 199
MS QuickBASIC 4.5	99 69
MS QuickC 2.0	99 69
MS Sort	195 139
MS Windows	99 69
MS Windows/386	195 130
MS Windows Development Kit	500 319
MS Word 5.0	450 285

MORTICE KERN SYSTEMS

MKS AWK	99 89
MKS LEX:YACC	249 219
MKS MAKE	149 135
MKS RCS	189 169
MKS SQPS	495 479
MKS Toolkit	199 179
MKS Trilogy	119 105
MKS VI	149 135

NOVELL

Btrieve	245 185
Btrieve for Dos 3.1 Networks	595 455
NetWare SQL	595 459
NetWare C Interface for DOS	295 239
NetWare System Calls for DOS	195 159
NetWare RPC	950 759
NetWare MHS	100 79
NetWare MHS Interface Guide	145 129
XQL	795 599
Xtrieve Plus	595 459

PROGRAMMER'S POLICIES

Phone Orders

Hours 9 AM-7 PM EST. We accept MasterCard, Visa, American Express. Include \$4.00 per item for shipping and handling. All shipments by UPS ground. Rush service available.

Mail Orders

POs by mail or fax are welcome. Please include phone number.

International Service

Phone number required with order. Call or fax for additional information.

Dealers and Corporate Accounts
Call for information.

Unbeatable Prices

We'll match nationally advertised prices. (Subject to same terms and conditions.)

Return Policy

30-day no-hassle return policy. Some manufacturer's products cannot be returned once disk seals are broken.

Lotus Magellan®

"Magellan ... is for those who don't care where anything is, as long as they can find it when they need it." [PC Magazine 3/28]

Lotus Magellan® is the ultimate utility for finding, viewing and using all the information on your PC. With Magellan, your hard disk information takes on new meaning. Simply because it's so quickly and easily accessible. It opens up a new way to discover, digest, compile, view, analyze and reflect upon your work. No matter what your level of use.

Order your copy today! List: \$139 Ours: CALL



Lotus®

VM/386

"VM/386 should be considered mandatory software as important as MS-DOS." ... Computer Language 10/88

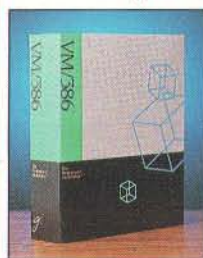

VM/386, PC Magazine Technical Excellence Award Winner, lets you create "virtual machines," each running its own MS-DOS application so you save valuable time while maximizing the performance of your 386 PC. Time consuming tasks like compiling code and running bulletin boards no longer tie up your PC, because they run simultaneously. VM/386 offers the highest level of data integrity and software compatibility available in a multitasking operating environment. Order your copy today!

IGC

List: \$245 Ours: \$199

Greenleaf SuperFunctions

Greenleaf's advanced library of over 360 functions for C with expanded coverage where you need it today. Greenleaf's SuperFunctions offer mouse support for text and graphics, logical windowing, expanded memory

support, advanced time/date functions, an integrated status/error return system, pull-down menu system, keyboard functions, and much more. The library comes with a 500 page manual, reference card, and FREE source code to all demos, functions and examples. This is the one C library a professional programmer should have.

List: \$265 Ours: \$189



TimeSlicer

TimeSlicer is the most popular linkable library of C functions for creating multitasking and real-time programs at the application level rather than interfacing with the operating system.

TimeSlicer will allow an unlimited number of tasks to be running concurrently. You can create, suspend or terminate tasks at run-time. Preemptive and non-preemptive modes are supported, as well as waking-up of tasks to optimize special event processing. TimeSlicer C functions can be installed to replace or complement any interrupt service routine.

TimeSlicer is the better choice for creating multitasking programs, giving you greater control and more efficient implementation of your multitasking application than its operating system counterparts.

List: \$295 Ours: \$279

LIFEBOAT®

In NY: 914-332-4548
Customer Service: 914-332-0869
International Orders: 914-332-4548
Telex: 510-601-7602

Fax: 914-332-4021

Call or Write for
Latest Free Catalog!

1-800-445-7899

Programmer's
Paradise



A Division of Voyager Software Corp
55 South Broadway, Tarrytown, NY 10591

Circle 214 on Reader Service Card

NOW YOUR SOFTWARE CAN TEST ITSELF.

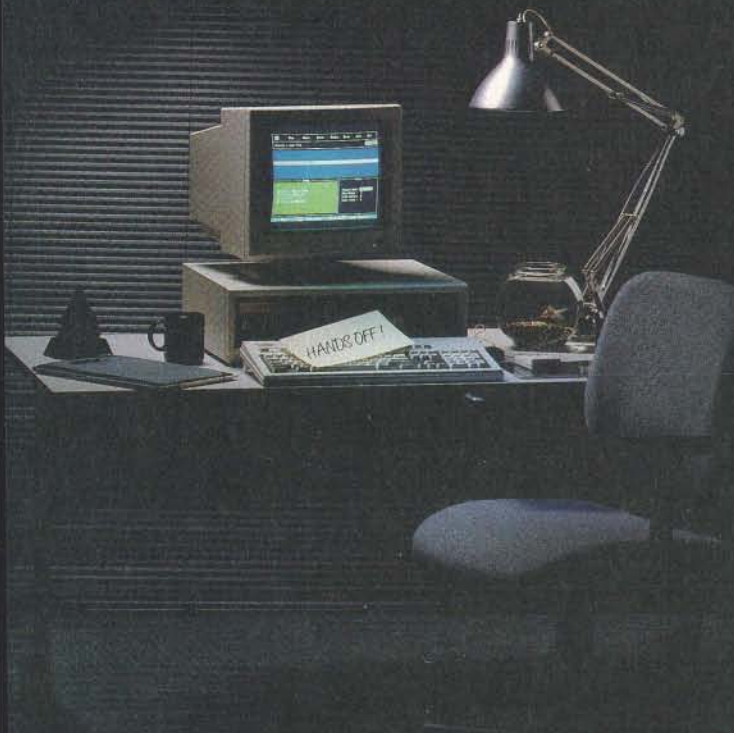

Your customers expect software that works. All the time. The key to software quality is exhaustive testing. It's also an engineer's worst nightmare. But it doesn't have to be. Because now you can automate your software testing.

Introducing the Atron Evaluator. The first and only non-intrusive automated PC-based software testing tool.

The Atron Evaluator automatically runs your software regression testing programs. All of them. All day. All night. Giving you thoroughly tested, higher quality software.

The Atron Evaluator is hardware-based. And since it's non-intrusive, software behavior is tested without the risk of alteration. Once your tests have run, you can refer to automatically generated test reports to double-check test results.

The Atron Evaluator saves time. And time makes you money. Development cycles are shortened, so your software gets to market sooner. And while your test programs are running, you can be more productive. Start a new project. Or go home.

For more information about the Atron Evaluator, call us at **1-800-283-5933**. And put an end to your worst nightmares. Automatically.



A Division of CADRE Technologies

Saratoga Office Center
12950 Saratoga Avenue
Saratoga, California 95070

Circle 28 on Reader Service Card

In Europe, contact:

Elverex Limited, Enterprise House
Plassey Technology Park, Limerick, Ireland
Phone: 061-338177

QA Training Limited, Cecily Hill Castle
Cirencester, Gloucestershire, GL7 2EF, England
Phone: (0285) 5888

WHAT'S NEW

HARDWARE • SYSTEMS

Micro Express Ships 33-MHz Machine

The ME 386-33 is an inexpensive zero-wait-state 33-MHz 80386-based system that includes 4 megabytes of 32-bit system memory, a 64K-byte cache, a floppy disk drive, and a 101-key AT-style keyboard.

A VGA monitor is optional, as are two hard disk drives: a 1.2-megabyte 5¼-inch drive or a 1.44-megabyte 3½-inch drive.

You can upgrade system memory to 8 megabytes on the American Megatrends motherboard and to 16 megabytes (total) with a daughterboard.

There are five half-height drive slots, plus two 8-bit, five 16-bit, and one 32-bit card slots, two serial ports, and one parallel port.

Price: \$5995; 140-megabyte hard disk drive, \$1500; VGA monitor, \$750.

Contact: Micro Express, 2114 South Grand Ave., Santa Ana, CA 92705, (800) 642-7621; in California, (714) 662-1973.

Inquiry 1126.

Unisys Winds Up to 25 MHz

The Personal Workstation² Series 800/25A is now the fastest Unisys micro-computer. It includes 2 megabytes of RAM (expandable to 18 megabytes), two 32-bit card slots, an 8-bit slot, five 16-bit slots, two RS-232C ports, a Centronics parallel port, and MS-DOS 4.01 with Windows/386 and GWBASIC.

Options include hard and floppy disk drives, a keyboard,



The 33-MHz Micro Express ME 80386 with optional floppy disk drive and VGA monitor.

a math coprocessor, and monitors. Monochrome monitors feature 720- by 350-pixel resolution (12-inch) and 640- by 350-pixel resolution (15-inch).

For networking, you can add up to two 320-megabyte hard disk drives and a 135-megabyte tape backup system through the SCSI port. There are five open slots for half-height 5¼-inch drives.

Price: \$7315; with floppy disk drive, \$7790; with 140-megabyte hard disk drive, \$10,685.

Contact: Unisys Corp., P.O. Box 500, Blue Bell, PA 19424, (215) 542-2244.

Inquiry 1127.

SEND US YOUR NEW PRODUCT RELEASE

We'd like to consider your product for publication. Send us full information, including its price, ship date, and an address and telephone number where readers can get further information. Send to New Products Editor, BYTE, One Phoenix Mill Lane, Peterborough, NH 03458. Information contained in these items is based on manufacturers' written statements and/or telephone interviews with BYTE reporters. BYTE has not formally reviewed each product mentioned. These items, along with additional new product announcements, are posted regularly on BIX in the microbytes.sw and microbytes.hw conferences.

in one 32-bit slot. That leaves three 8-bit slots and four 16-bit slots open.

Price: \$999.

Contact: HiTech International, 712 Charcot Ave., San Jose, CA 95131, (408) 435-8827.

Inquiry 1124.

Toshiba Lightens Up

Toshiba's latest laptop, the T1600, weighs just 11½ pounds and runs at 12 MHz.

It features a megabyte of RAM (upgradable to 5 megabytes), a 20-megabyte hard disk drive and a 1.44-megabyte 3½-inch PS/2-compatible floppy disk drive.

The backlit supertwist LCD display is EGA compatible and offers a resolution of 640 by 400 pixels. The screen displays a full 80 characters by 25 lines. It's also detachable.

Each of the two standard-equipment batteries weighs 15 ounces and is removable and rechargeable. One battery defaults to the other when the first one gets to a certain low-energy point.

Bundled software includes MS-DOS 3.3, PC-Kwik Power Pak disk-cache utility software by Microsoft, and hyper-text disk-resident DOS. Options include an external 360K-byte 5¼-inch floppy disk drive and a 17-key numeric keypad.

Price: \$4999.

Contact: Toshiba America, Inc., Information Systems Division, 9740 Irvine Blvd., Irvine, CA 92718, (800) 457-7777; in California, (714) 583-3000.

Inquiry 1125.

continued

Removable Drive for IBMs and Apples

The Maxi RD45 is a 45-megabyte removable SCSI hard disk drive system that features an average access time of 25 ms and works on both IBM PCs and Macs.

With the half-length XT/AT kit or the Micro Channel full-length kit, you can daisy-chain up to seven drives. Whichever system you use, the data transfer rate is 500K bytes per second.

Each cartridge measures 5½ inches square and fits into the internal or external 5¼-inch form factor mounts. A write-protect switch on the cartridge protects the disks from accidental overwriting; a cartridge-locking mechanism prevents accidental removal during read/write sessions.

Drive packages contain necessary SCSI connectors, terminators, and one cartridge.

Price: Internal, \$1325; external, \$1625; Mac interface kit, \$80; MCA kit, \$250.

Contact: Sysgen, Inc., 556 Gibraltar Dr., Milpitas, CA 95035, (800) 821-2151; in California, (408) 263-4411. **Inquiry 1130.**

C.Itoh's 18-pin Dot-Matrix Printer for LANs

The ProWriter CI-5000 is an 18-pin monochrome (color optional) dot-matrix printer that's designed as a shared network printer, according to C.Itoh.

The ProWriter CI-5000 prints in draft mode at up to 540 cps, 100 cps in near-letter-quality mode, and 73 cps in letter-quality mode. C.Itoh reports.

C.Itoh claims compatibil-



The Maxi RD45 is a removable hard disk system.

ity with the IBM ProPrinter XL, the Epson FX-286e, and DEC's LA210/LA75/LA50 printers. Paper can be up to 16 inches wide. Paper feed can be friction or tractor-pin in forward and reverse directions. The 33-pound machine measures 6 by 23 by 18 inches.

For networking, there are ports for parallel and RS-232C connectors as well as a 6-pin RS-423 for DECnet and

MicroVAX connections.

A port on the printer's left side allows future enhancements with font cartridges and RAM upgrades (up to 128K bytes). The printer includes 8K bytes of RAM.

Price: \$1995.

Contact: C.Itoh Electronics, Inc., 2505 McCabe Way, Irvine, CA 92714, (800) 227-0315; in California, (714) 660-1421.

Inquiry 1129.

Hewlett-Packard's DeskJet Plus

The DeskJet Plus is an updated version of the original DeskJet that includes landscape mode, additional built-in fonts (6 portrait and 4 landscape), and revised proportionally spaced text.

Because paper and processor throughput have been improved, the HP DeskJet Plus produces a page of text up to twice as fast as the original. Rated print speeds of both printers are the same—120 cps, or about two pages per minute, for laser quality and 240 cps for draft.

A faster microprocessor on the new printer, however, improves formatting speed, and a faster paper motor and paper pick-up mechanism moves a page through the printer in half the time of the original mode.

Price: \$995.

Contact: Hewlett-Packard Co., Inquiries, 19310 Pruneridge Ave., Cupertino, CA 95014, (800) 752-0900.

Inquiry 1128.

continued

This Touchscreen Works with Macintosh Software

The Mac 'n Touch Monitor is a Magnavox display that includes an integral touchscreen, a controller, cable, and driver software that enables the touchscreen to be used with all Macintosh software, including HyperCard. It interfaces to the Mac II over the Apple Desktop Bus (ADB).

The screen consists of a single glass sheet with a coating bonded to its surface to keep it sensitive to touch yet protect it from scratches and from oils on your skin. The coating helps ensure that every point on the screen will accurately read at least 2 million touches.

The touchscreen technology is called analog capacitive sensing, MicroTouch says. Electrodes on the sides of the screen place a linear voltage field across the screen so the controller measures the position of a capacitive coupling from a finger or a conductive stylus.

The ADB allows for conversion speed at 60 touches per second. Optical clarity is 85 percent light transmission, slightly less than clear glass, which restricts about 12 percent of the light.

Display resolution is 640 by 480 pixels, with 256 colors available from a palette of 16 million. Touch res-

olution is 1024 touch points per axis. The screen's controller automatically averages the entire area of touch contact so your finger can effectively address an individual pixel.

In what MicroTouch calls "lift-off mode," an initial touch locates the cursor. But when you lift your finger off the screen, you get the equivalent of a mouse click. A subsequent tap produces either a double click or a drag.

Price: \$1545.

Contact: MicroTouch Systems, Inc., 10 State St., Woburn, MA 01801, (617) 935-0080.

Inquiry 1131.

After centuries of practice, mankind perfects engineering calculations: MathCAD.

Announcing MathCAD 2.5: The Dawn of a New Age.

What the historians will call it, only time will tell.

Perhaps the Century of Speed, or the Era of Ease. But whatever the name, this is the age of MathCAD 2.5, the only math package that looks and works the way you think.

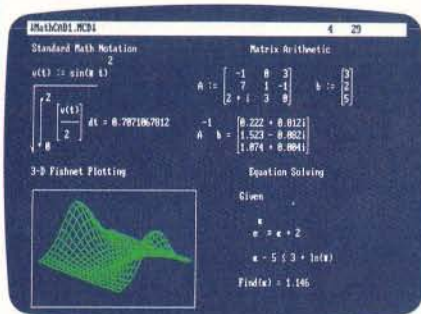

MathCAD 2.5 includes 3-D plotting, HPGL sketch import, and PostScript output.

MathCAD is far and away the best-selling math package in the world. Because it lets you perform engineering and scientific calculations in a way that's faster, more natural and less error-prone than the way you're doing them now—whether you're using a scratchpad, calculator, spreadsheet or program that you wrote yourself.

And now we've made the best even better. MathCAD 2.5 is a dramatically improved version that includes three-dimensional plotting, enhanced numerical analysis, and the ability to import HPGL files from most popular CAD programs, including AutoCAD.[®] And now you can print on PostScript[®] compatible printers.

And like before, MathCAD's live document interface™ lets you enter

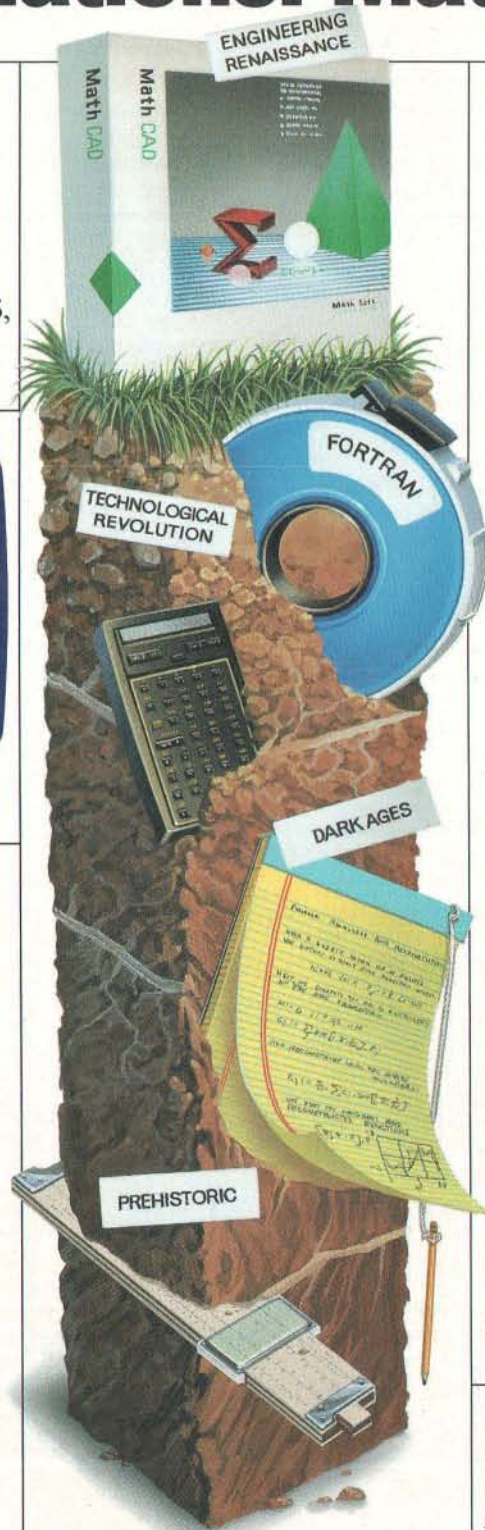

equations anywhere on the screen, add text to support your work, and graph the results. Then print your analysis in presentation-quality documents.

It has over 120 commonly used functions built right in, for handling equations and formulas, as well as exponentials, differentials, cubic splines, FFTs and matrices.

No matter what kind of math you do, MathCAD 2.5 has a solution for you. In fact, it's used by over 50,000 engineers and scientists, including electrical, industrial, and mechanical engineers, physicists, biologists, and economists.

But don't take our word for it; just ask the experts. PC Magazine recently described MathCAD as "everything you have ever dreamed of in a mathematical toolbox."



March 14, 1989 issue. Best of '88 Best of '87

And for Macintosh[®] users, we present MathCAD 2.0, rewritten to take full advantage of the Macintosh interface. Entering operators and Greek letters into equations is pure simplicity!

Look for MathCAD 2.5 at your local software dealer, or give us a call. For more information, a free demo disk, or upgrade information,* dial 1-800-MATHCAD (in MA, 617-577-1017).

*If you purchased MathCAD 2.0 between 5/1/89 and 6/16/89, you can get a FREE upgrade to version 2.5 (otherwise, the upgrade cost is \$99.00 until June 30, 1989; afterwards, the cost will be \$149.00).

MathCAD[®]

MathSoft, Inc. One Kendall Square, Cambridge, MA 02139

Number Crunching with a 50-MHz Bus Master Board

A coprocessor board for your AT, the AT-Super combines the speed of a 32-bit RISC CPU with the convenience of MS-DOS.

The AT-Super has a 50-MHz AM29000 32-bit RISC coprocessor (with separate instruction and address buses) for MS-DOS applications. Peak performance is rated at 25 MIPS, and sustained performance is rated at 17 MIPS. The board has 2 megabytes of instruction RAM and 512K bytes of static RAM.

There's also a bus-mastering mode that can increase performance for graphics-intensive, memory-intensive, and I/O-intensive applications.

In the bus-mastering mode, a "sequencer" chip on the coprocessor card generates the RISC signals and bypasses the CPU (effectively mastering the bus—thus the name) for control of the video card, for example. With the bus-mastering technology, Yarc says, the coprocessor writes directly to the video card or the memory or the peripherals.

Yarc software operating under DESQview allows for four separate concurrent tasks, so you can theoretically install up to four AT-Supers on each of your systems.

Price: \$4595.

Contact: Yarc Systems Corp., 5655 Lindero Canyon, Suite 721, Westlake Village, CA 91362, (818) 889-4388.

Inquiry 1134.

DPT Adds Mirroring to Controller

The SmartCache Mirroring kit for Distributed Processing Technology's SmartCache disk controller

provides transparent, fault-tolerant disk storage for the IBM PC and compatibles, regardless of the application and operating system. It's designed for a network file server, a multiuser system, or a CAD workstation.

After installing the kit on the main controller board, you add a second redundant drive to handle the mirrored information. If one of the drives fails, the controller automatically switches to the second drive.

The SmartCache Mirroring kit offloads hard disk mirroring overhead from your host CPU to the 68000 CPU on the controller.

DPT claims its caching controller decreases effective hard disk access time by up to 150 times, to about 0.5 ms. Because the DPT controller operates without special software drivers, you can use the SmartCache Mirroring kit with any operating system.

In addition to protection from catastrophic drive failure, SmartCache Mirroring protects the user from disk defects by automatically patching bad sectors when defects occur with good data from the mirror drive. Since the controller handles all disk defect management, it can repair disk defects in a manner transparent to the operating system. An audible alarm is provided that tells the user to install a new drive and restore all data onto it from the mirror drive.

Price: Kit and controller, \$1950; upgrade kit alone for SmartCache controllers, \$800.

Contact: Distributed Processing Technology, 132 Candace Dr., P.O. Box 1864, Maitland, FL 32751, (407) 830-5522.

Inquiry 1133.

New Frame Grabber for PCs

Video Publisher GS from Willow Peripherals offers 8-bit gray scaling at up to six user-selected resolutions and digitizes at roughly six frames per second.

Two versions of the board are available. The low-end model will support user-selectable scanning resolutions of 256 by 240, 320 by 200, 512 by 240, and 640 by 200 pixels. The high-end board will support 512-by-480-pixel resolution.

The board is shipped with an upgraded version of the software for Publishers' VGA that allows editing and manipulating of saved video images and file conversion to graphics formats such as TIFF, PCX, and EPS. Images can also be enhanced with software such as Deluxe-Paint II or Publishers' Paintbrush and exported to desktop publishing packages such as Aldus PageMaker or Ventura Publisher.

Price: \$450 to \$595.

Contact: Willow Peripherals, 190 Willow Ave., Bronx, NY 10454, (800) 444-1585; in New York, (212) 402-0010.

Inquiry 1199.

Hercules Unchains Low-Cost VGA Card

This low-cost Hercules VGA card is compatible with the IBM VGA adapter.

The card couples Intel's 82706 VGA controller chip with a Hercules proprietary video BIOS. The Hercules card is designed to exactly emulate IBM's card. It has no jumpers, switches, or special software drivers.

It works with any standard VGA analog monitor or multi-sync monitors with analog

capabilities. But it isn't compatible with the older monochrome Hercules standard.

Price: \$299.

Contact: Hercules Computer Technology, Inc., 921 Parker St., Berkeley, CA 94710, (800) 532-0600; in California, (415) 540-6000.

Inquiry 1135.

hyperStore Your Hard Disk Information

The hyperStore/816 is an intelligent hard disk controller board that maintains a continuous data transfer rate of up to 2 megabytes per second, the manufacturer claims. Average access time of data in cache is 0.5 ms.

It's based on the 16-bit Zilog Z80280 microprocessor and includes a half-megabyte of RAM for caching, though it can use up to 4 megabytes. It also includes an on-board controller for floppy disk drives and related peripherals.

The board's operating system, hSOS, is stored in CMOS RAM. To make the most of this RAM cache, the hyperStore uses an approach called "scatter/gather" reads and writes. Random disk reads are analyzed for patterns, and the data is sorted sequentially to keep disk head movements to a minimum.

The hyperStore/816 is currently available only in a modified frequency modulation (MFM) version, though upgraded versions for the run-length-limited (RLL) and SCSI hard disk drives are scheduled to ship later this summer.

Price: \$1195.

Contact: Perceptive Solutions, Inc., 1509 Falcon, Suite 104, DeSoto, TX 75115, (800) 343-0903; in Texas, (214) 224-6774.

Inquiry 1136.

continued

Pull out all the stops

Turbo C® Professional is the *only* production-quality C compiler with a completely integrated environment.

Everything you need—all the tools—are *included* in this environment, so you never waste time stopping, starting, and switching between tools.

And you're not forced into trade-offs between high-productivity programming and small, fast, reliable code. Instead you get the fastest and the best of both worlds.

There's tight integration between editor, compiler, linker, and debugger that lets you race through your program with a fast edit/compile/run/debug cycle.

Only Turbo C Professional gets it all together

Now everything you need to write *and debug* production-quality, optimized code in *both* C and

Assembly language is all yours in one package.

With Turbo C Professional you get:

- Turbo C 2.0 with its own integrated development environment—Compiler, Editor, Debugger, and Linker.
- Plus a separate command-line C Compiler
- Turbo Assembler®—a complete Macro Assembler that's more compatible with MASM than MASM is with itself.
- And the new source-level Turbo Debugger® that lets you debug *any size program*. Turbo C Professional has it all.

Turbo C 2.0

- Compiles over 16,000 lines per minute
- Hypertext online Help
- Supports inline assembly
- All six memory models supported
- More than 450 library functions

Turbo Assembler

- Assembles up to 48,000 lines per minute
- Compatible with MASM 4.0, 5.0, 5.1
- Full 386 support
- Assembles multiple files

Turbo Debugger

- Debug any size program
- Browse through structures with data debugging
- Set conditional breakpoints, break on memory access
- Stop, run code, log expressions
- 386 ICE capabilities



Turbo Debugger is a winner

Turbo Debugger won *PC Magazine's* most recent Award for Technical Excellence, and here's what they said:

"Everyone who's tried the Turbo Debugger agrees. It wins the (development tool) category's award for Technical Excellence hands down. The user interface is simple yet elegant; the program works the way programmers want to work. Yet again, Borland has advanced the state of the art in an eminently useful way."

Bill Machrone, Editor-in-Chief, *PC Magazine*

Debug any size program

Turbo Debugger lets you debug on a remote machine. That's a win. And in virtual mode of the 386, it allows you to debug *any size program*. Even your largest—*especially* your largest. That's a *huge* win.

And it can give you 12 *different* views of your code. It supports browse-through data debugging; offers flexible breakpoints; supports in-circuit emulation; offers EMS support; has a "Point & Shoot" integrated debugging environment, and is completely CodeView® compatible. Turbo C Professional does all that, so it wins—and so do you.

Pull out all the stops

Turbo C's integrated environment lets you completely stop stopping. Your program is never interrupted. No stops and no gaps. You compile faster. Link faster. Work faster. Think faster. So turn to Turbo C Professional: There's nothing stopping you now.

This is no ordinary Demo

Not one, not two, but three different demos on the same disk: Turbo C, Turbo Pascal,® and Turbo Debugger. We'll send you the demo disk and fact sheets with technical information for \$4.95. **To order, CALL (800) 345-2888 Ext. 200**

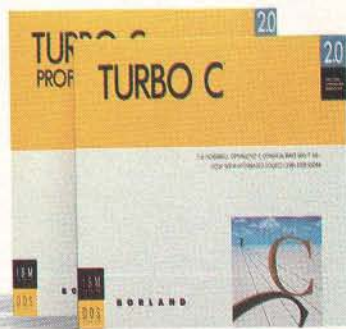

Turbo C, Turbo Pascal, Turbo Assembler, and Turbo Debugger are registered trademarks of Borland International. Copyright © 1989, Borland International, Inc. All right reserved. BI 1286

Code: MC10

B O R L A N D

Circle 48 on Reader Service Card (DEALERS: 49)

The new COMPAQ DESKPRO 286e.
Further proof that what's on the outside,



says a lot about what's on the inside.

Compaq has earned a reputation for building the most powerful and reliable personal computers in the world.

In doing this, we've always given users the best combination of features needed to do their jobs.

We've also never given up the belief that even the most basic needs deserve more than just basic solutions.

As further proof, we offer the COMPAQ DESKPRO 286e Personal Computer.

It brings together a 12-MHz 286 microprocessor and a long list of integrated features. All in a compact package that runs the latest applications, without



Five expansion slots give you room to grow: one for high-speed memory, and four for thousands of industry-standard add-ins.

taking up more desk space.

Your users will find everything they need in a stand-alone

PC, perfect for their growing business productivity applications.

You'll also find a PC that's been rigorously tested with a wide range of network products, so it's compatible in virtually any network environment.

Now for an inside look. High-performance VGA graphics are built right on the system board. So your users

Built-in interfaces mean you can connect a mouse, printer, modem or other tools without taking up a slot.



can have displays that are easier to read. You, in turn, will have compatibility with all your EGA- and CGA-specific software plus performance that's up to 50% faster than other VGA controllers.

In memory, one megabyte is standard and is expandable in increments up to 13 megabytes using a separate high-speed memory expansion slot.



This leaves four industry-standard expansion slots open for LAN cards, mainframe links, etc. to customize the COMPAQ DESKPRO 286e to your users' needs.

You can take customization a step further. The COMPAQ

You'll get the flexibility to use both 5 1/4- and 3 1/2-inch diskette drives, along with a wide variety of fixed disk drives and tape drives.



DESKPRO 286e can be configured with up to four internal storage devices. Choose fast 110-, 40- and 20-MB fixed disk drives; both 5 1/4- and 3 1/2-inch diskette drives; even tape drives.

As you can see, the new COMPAQ DESKPRO 286e offers the same attention to detail that has made the COMPAQ name unmatched for performance, quality and reliability.

For a free brochure on the COMPAQ DESKPRO 286e and the location of an Authorized COMPAQ Computer Dealer near you, call 1-800-231-0900, Operator 92. In Canada, just call 1-800-263-5868, Operator 92.

COMPAQ

It simply works better.

Alloy Ships 386/MultiWare

Alloy's 386/MultiWare is a multiuser, multitasking environment that networks up to 20 PCs to a single 80386-based system. Each terminal can run all existing DOS applications in a multiuser environment, Alloy claims.

It consists of the software for your 80386, 386/MultiWare, and an IBM PC AT- or PS/2-compatible board.

The NX386E is a five-user version of 386/MultiWare that works with the IMP2 add-in board, providing RS-232C communications for two terminals (any PC or Apple product with a serial port running Alloy's terminal emulation software).

Multiuser communications are handled by emulation of Novell's File and Record Locking and a similar Microsoft networking software. Multitasking is handled with the Alt-F8 key combination through each add-in board's V20 microprocessor (which is essentially comparable to the 8088). Each IMP2 board also contains 32K bytes of RAM

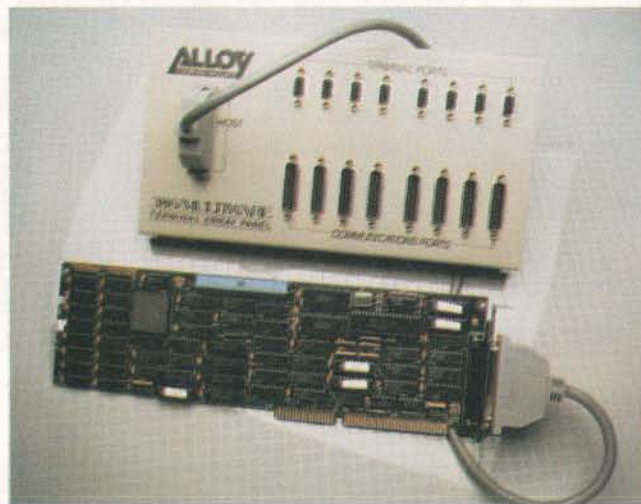

Alloy's IMP8 board supports eight users through the RS-232C panel.

and is available in AT and PS/2 versions. Two IMP2 boards can be used in conjunction with each other, each handling two users plus the host, for a total of five users.

In its full-blown configuration, 386/MultiWare consists of the NX386 software, two IMP2 boards, two IMP8 boards, and two peripherals called Terminal Array Panels.

Each IMP8 also gives you a V30 microprocessor (which is similar to the 80186), 576K bytes of RAM, and a Terminal Array Panel that has eight 9-pin RS-232C con-

nectors for your terminals and eight 25-pin connectors for connection to printers, modems, or faxes.

Price: Basic 386/MultiWare, NX386E, \$395; full 386/MultiWare, NX386, \$995; basic board, IMP2, \$495; full board, IMP8 including Terminal Array Panel, \$1995.

Contact: Alloy Computer Products, Inc., 100 Pennsylvania Ave., Framingham, MA 01701, (800) 451-8753; in Massachusetts, (508) 875-6100.

Inquiry 1143.

Serially Connect Up to 256 Devices

PortNet lets you connect up to 256 devices in eight-port groups, with each group as much as a kilometer away from the master switch. It uses unshielded twisted-pair cabling through RS-232C ports. Data transfer rates range from 300 bps to 38,400 bps, and you use your familiar PC communications software.

The Master Switch (MS1000) acts as a file server for the Remote Distribution Units, with a maximum of 32 remotes per MS1000.

Each MS1000 includes a power supply, a motherboard, an Zilog Super8 microprocessor, a backplane for the add-in boards, and about 20K bytes of RAM for setting up the network.

Price: MS1000, \$1950; RDU, \$495; printed circuit board, \$495.

Contact: CBM Electronics, Inc., 160 McCormick Ave., Costa Mesa, CA 92626, (800) 767-8638; in California, (714) 241-8194.

Inquiry 1144.

continued

IBM Ships ISDN Adapter

The 7820-001 is IBM's version of an all-in-one ISDN terminal for microcomputers, minicomputers, and mainframes with standard interfaces. It's the equivalent of a modem for the digital electronics that telephone companies are installing.

For personal computer hookup, IBM supplies a module with a V.24 (RS-232C) port. In addition to supporting full-duplex communication, it supports half-duplex communication rates between 4800 bps and 19,200 bps.

The V.35-compatible

module supports transmission rates of 48,000 bps, 56,000 bps, and 64,000 bps. The X.21 module, used mostly for European telecommunications, will support transmission of 4800 bps, 9600 bps, 48,000 bps, and 64,000 bps.

Once the 7820-001 is hooked up, it connects to what AT&T calls a network termination device, an NT1, to adapt the four wires that come out of the 7820-001 with the twisted-pair of copper that constitutes standard telephone wiring.

The fully configured

7820-001 is designed for point-to-point communications. IBM has, however, engineered the device in accordance with CCITT recommendations, so the electronics are available for you to run as many as eight personal computers or other devices through a single 7820-001 in a passive bus configuration.

The terminal adapter is about the size of a college dictionary. The back has three holes for plug-in modules, offering both the S and T ISDN interfaces, as defined by the CCITT. The

modules are currently based on an LPDA-2 command set, the Hayes standard sometimes referred to as LAP-D. The terminal adapter has a modular back end, so microcode can be changed to accommodate changes in software on the central-office computers.

Price: 7820-001 without interface modules, \$1628; RS-232C module, \$525; V.35 module, \$630; X.21 module, \$525.

Contact: IBM Corp.; check your local white pages or call (800) 426-2468.

Inquiry 1145.

ScanMan™. Turning imaginations loose everywhere.

Pop any image up to 4" x 11" straight into any IBM personal computer or Apple Mac™!

Select one, two, three or four hundred D.P.I. Resize, rotate, flip and edit it. With the IBM version, use PaintShow Plus™ (included free) for coloring and shading, then port into any popular publishing program.

With the Mac ScanMan use the Clipboard™ to transfer the image to virtually any application — the Mac ScanMan works just like any Desk Accessory!

ScanMan for the PC — \$339
 Multi-Channel version — \$399
 Macintosh version — \$499

For your nearest dealer, call:
800-231-7717

In California:
800-552-8885

In Europe:
 + + 41-21-869-96-56

Circle 157 on Reader Service Card
 (DEALERS: 158)



Chronos Groupware Answers Who's on First When

Who-What-When Enterprise is a groupware version of the personal information manager from Chronos.

To run Who-What-When Enterprise, you need a DOS 3.1-compatible network operating system like NetWare, VINES, or 3+ Open. It's designed to handle all users on your server-based network.

The program requires 420K bytes of RAM in each machine; 512K bytes is recommended. The file server must have space for 380K bytes in addition to the resident memory on the nodes. Part of the RAM is used for Btrieve, which is shipped with the product.

Who-What-When Enterprise is an extension of Who-What-When, which features a calendar function, among other things. With Who-What-When, you block out time periods in the days, weeks, months, and years ahead.

The Enterprise version allows real-time group scheduling and coordination. But you can't yet copy the group information to the single-user Who-What-When. When you travel, you have to print your schedule from Enterprise, make hand notes, and update Enterprise when you return.

Price: Single-server site license, \$695; upgrade from the single-user version, \$695 minus a rebate (unspecified at press time).
Contact: Chronos Software, Inc., 555 DeHaro, Suite 240, San Francisco, CA 94107, (800) 777-7907; in California, (415) 626-4244.
Inquiry 1148.

WHEN	WHO	WHAT	DESCRIPTION
8:30a	STAN	SALES:	Review annual sales data
8:40a	Others	SALES:	Meet to discuss new sales goals
9:30a	FETER	EQPT:SELECT	Meeting to discuss equipment selection specifications
10:45a	KEN	SALES:	International conference call
11:15a	MARTHA	LEGAL:	Call to review contract items
12:00p		Memo: LEGAL	Lunch with Metware Developer Forum
1:30p		CATALOG:	Review final art & copy
2:00p	A STAN	SALES:	Second quarter projections
3:30p	B MARTHA	LEGAL:	Summarize Japan Contract Items

The Who-What-When daily calendar becomes groupware.

Biscom's Fax System Networks PostScript

The FAXCOM/Publisher is a stand-alone print-processing computer that allows computers to send PostScript files via Group 3 fax.

The tower-style system, which emulates an Epson printer, will work with a wide variety of microcomputer LANs, as well as networks from IBM, DEC, Wang, Hewlett-Packard, and Tandem.

It's based around an 80386 with 4 megabytes of RAM and a graphics coprocessor (for the PostScript algorithms). PostScript files can be sent through your network to the file server, which, in turn, is serially connected to the FAXCOM/Publisher.

This eliminates the need to print out PostScript documents and feed them manually into a fax machine. It differs from fax-on-a-board PC products in that multiple computers can send documents through the server.

The new system, a super-set of an existing product from Biscom called FAXCOM 1000+, takes about a minute per page to prepare documents (comparable to many PostScript printers) and transmits at the fax rate of 9600 bps. In the future, Bis-

com has promised support for graphical standards other than PostScript through the FAXCOM computer.

Price: Under \$10,000.

Contact: Biscom, Inc., Forest Ridge Research Park, 85 Rangeway Rd., Billerica, MA 01821, (508) 670-5521.
Inquiry 1149.

Adapter Cards and MAUs Enhance Token Rings

The 4-Mbps variety of IBM-compatible token-ring LANs continues to grow in popularity despite IBM's recent introduction of a 16-Mbps token ring.

MCA Ring Node is a communications adapter card that connects IBM PS/2 Micro Channel-based machines to a 4-Mbps token-ring network.

Each MCA card is compatible with the IEEE 802.2 Logical Link Control standard, and each uses the 802.5-defined token-passing protocol.

The cards are software-compatible with Novell's NetWare, Microsoft's LAN Manager, IBM's PC-LAN, and Madge's Netserver.
Price: \$695; file server, \$895.

Contact: Madge Networks, 534 Salem Ave. SW, Roanoke, VA 24016, (703) 982-0638.
Inquiry 1150.

TokenCard and TokenHub help you attach IBM PCs and compatibles to your 4-Mbps token-ring networks. TokenCards link up to 260 stations in a single ring. Each TokenCard has the standard 9-pin D connector for shielded twisted-pair cabling and an RJ-11 for unshielded twisted-pair cabling.

TokenHub is a four-port multistation access unit (MAU) that lets you connect up to four TokenCards at a single network wiring access point.

The TokenCard for the file server includes 128K bytes of RAM for buffering and to download the LCC software. Software drivers for Novell's NetWare are included, and support will include Microsoft's OS/2 LAN Manager.

Price: TokenCard WS (for your PC), \$499; TokenCard (for your file server), \$599; TokenHub, \$399; TokenHub power supply, \$89.

Contact: Western Digital Corp., 2445 McCabe Way, Irvine, CA 92714, (714) 863-0102.

Inquiry 1151.

Thomas-Conrad's first token-ring product, an MAU, has twice as many ports as traditional eight-port MAUs. The TC4050 is designed for 4- and 16-Mbps networks and features diagnostic capabilities.

Maximum distance to a workstation is 100 meters, and the company claims you can daisy chain these MAUs without signal degradation.

Price: \$985.

Contact: Thomas-Conrad Corp., 8403 Cross Park Dr., Building One/C, Austin, TX 78754, (800) 332-8683; in Texas, (512) 836-1935.

Inquiry 1152.

continued

Rupp Corporation Presents

Power Products Showcase No. 19

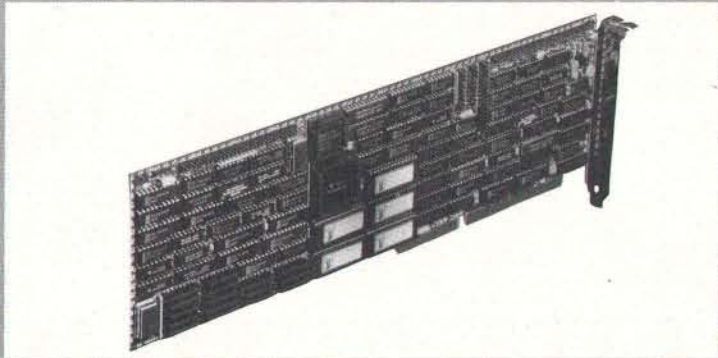

PM3011 CACHING CONTROLLER

Up to 16MB of hardware implemented cache for ESDI, RLL of ST506 drives.

Product Profile: The PM3011 caching controller is the single most effective performance improvement tool available for disk-intensive applications. The PM3011 accesses data in as little as 0.5ms; that's 50 to 150 times faster than a random disk access.

Advanced Caching Algorithms: Such advanced caching features as disk read ahead and elevator sorting during cache write-back increase disk performance to levels unattainable by non-caching controllers. The controller's on-board 68000 microprocessor enables it to access the disk

drive at the same time as the computer reads or writes to the controller cache.

Compatibility: Since PM3011 caching controllers operate transparently to the operating system, special software drivers or ROM BIOS changes are not required.

Up to 16MB of Cache: The PM3011 Cache RAM is expandable from the on-board 512KB to 16MB with the optional Cache Expansion board. The cache is totally independent from system memory and does not require device drivers.

PM3011/70 Caching Controller With 512KB cache. **\$1150**

DPT Introduces Hardware Disk Mirroring

Distributed Processing Technology, the leader in the field of Caching Disk Controllers, has announced a long-awaited addition to its product line—Hardware Disk Mirroring.

Hardware Disk Mirroring provides true fault tolerant disk storage for PC/AT systems regardless of the application and operating system environment. It is available for all DPT PM3011 Caching Disk Controllers supporting ST506, RLL, and ESDI drives.

Disk mirroring is important in environments where disk data integrity is vital, such as network file servers, multiuser systems, and CAD workstations. Since the DPT caching disk controllers operate without special software drivers, the mirroring feature is transparent.

The Hardware Disk Mirroring can be added to PM3011 controllers as a field upgrade by installing a DM3011 Key Card directly onto the controller.

DM3011 **\$795**



FAST HARDDISKS

Wren V Full-Height 5 1/4" Disk Drives Product Profile Wren V and WREN IV Full-Height disk drives offer the utmost in capacity, performance and reliability. You can get unformatted capacity up to 766 megabytes, seek time as fast as 14.5ms and transfer rates up to 15MHz.

CDC drives are known industry wide for their reliability and performance. Manufacturers such as Compaq have been using CDC drives for years.

Model No. Capacity (Mbytes)	WREN V SPECIFICATIONS		
	WREN V 94186	WREN V 94186	WREN VI 94196
Unformatted	383	442	766
Disks	8	8	8
Data Surfaces	15	15	15
Average Latency	8.3	8.3	8.33
Average Seek	14.5	16	16.5
Interface	ESDI	ESDI	ESDI
Transfer Rate	10	10	15
MTBF (hours)	40,000	40,000	40,000
Price	\$2800.00	\$2900.00	\$Call

*For pricing on RLL, ST506 controllers and other options please call

Call 212-517-7775

Fax 212-249-8243

Dealer Inquiries Welcome

Charge Cards Accepted: Amex, Visa, MC
Hours (EST) 9:00 to 5:00



Exceptional Computer Products

Rupp Corporation
835 Madison Avenue
New York City, NY 10021

Circle 244 on Reader Service Card

Spreadsheet Rivalry Heats Up

to meet the...
officials...
finally ap...
that the...
erent ver...
ing in-l...
ny.

products are not enough if software is not displayed in computer stores.

for

Things are getting down and dirty, a computer analyst observes.

Dealers who have seen what will be...
new promo...

The Spreadsheet Market

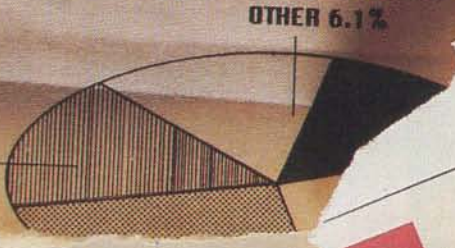

RACE VS. PO

ust when t...
establishe...
ack

We Interrupt T War For This Im

To all those unlucky enough to be stuck smack in the middle of the current spreadsheet confusion, take heart.

There is, at last, a viable alternative to war: revolution.

One that delivers even more performance than you have (ahem) been waiting for, but without demanding expensive new hardware or extensive retraining. And without abruptly cutting you off from any user in your company, even those on mainframes.

The name of the spreadsheet is SuperCalc[®] 5.

And what it can do for you is, frankly, quite revolutionary.

Let's begin at the end. Stand-alone quality graphic capabilities have been built in.

Offering hundreds of presentation treatments from word charts to three-dimensional bar, pie, scatter, and polar graphs.

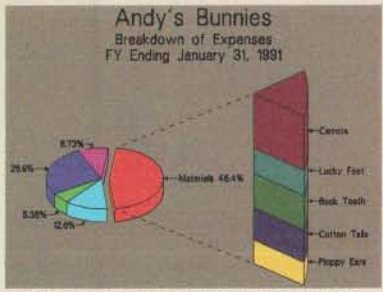

Andy's Bunnies
Mid-Year Consolidation

	North	South	East	West	Total
Line	\$164,189	\$288,445	\$389,951	\$945,317	\$1,787,902
Deceased	\$141,456	\$159,268	\$197,663	\$184,777	\$683,164

Quarter 2 Results

	North	South	East	West	Total
Line	\$287,444	\$279,883	\$444,898	\$281,428	\$1,393,753
Deceased	\$64,567	\$78,824	\$97,621	\$89,955	\$330,967

Quarter 1 Results

	North	South	East	West	Total
Line	\$224,665	\$387,482	\$445,461	\$413,889	\$1,471,597
Deceased	\$76,889	\$88,444	\$186,842	\$96,222	\$448,397

Link just about everything in sight.

And with SuperCalc5, you select fonts, lines, boxes, grids and shading. All of which can be used to produce the highest quality customized reports.

Plus, SuperCalc5 actually makes productivity easier. An integrated Undo feature simply reverses unwanted commands. And a truly comprehensive system of debugging highlights costly errors and analyzes macro logic.

Perhaps even more impressive



Catch bugs before they come back to bite you.

POWER TION

the field had been ranked and the odds of a national computer spreadsheet software...

New program
...to fend off
Spreadsheet war

Spreadsheets
Ready to Pounce

January 28, 1989

at Gain
on River
creating a spreadsheet

The Spreadsheet

portant Update.

to be precise. Linking either in memory or on disk, either pages of the same spreadsheet or independent, either SuperCalc5's files or Lotus® 1-2-3®'s.

and compatible computers but also takes full advantage of 286 and 386 machines when you decide to make that transition.

And if all that isn't enough to make you run out today and join the revolution, there's even more incentive.

Which brings us to the "L" word. SuperCalc5 not only reads and writes Lotus® 1-2-3® files, it totally coexists with Lotus.

Like our free demo disk offer through July 31, 1989. And our \$100 upgrade offer for just about any spreadsheet you're using. Call 1-800-531-5236. In Canada call 1-800-663-6904.

Which finally brings us to our admittedly biased outlook for the much touted spreadsheet war. With SuperCalc5, peace is at hand.

Andy's Bunnies

Income Statement
FY Ending January 31, 1991
Unaudited

	This Year	Last Year
Revenue		
Sales		
Live	\$1,728,433	\$4,589,879
Theatrical	\$1,444,778	\$4,721,151
Sales Discounts	(643,990)	(429,234)
Merchandise Fees	\$78,971	232,838
	\$2,488,292	\$9,114,634
Cost of Sales		
Opening Inventory	\$9,663,331	\$5,626,712
Purchases	\$109,814	\$4,212,544
Freight in	\$56,727	\$42,545
Ending Inventory	\$9,324,392	\$9,583,139
Cost of materials	\$2,384,130	\$1,645,231
	\$1,674,782	\$592,937
Direct Labor	\$1,467,351	\$1,277,343
Employee benefits	\$29,589	\$25,489
Wages supplies	\$679,444	\$615,045
Total Cost of Sales	\$4,911,767	\$3,589,951
Gross Profit	\$2,596,462	\$1,710,317
Less selling, general and admin expenses	\$449,887	\$449,774
Earnings (Loss) from operations	\$2,086,575	\$1,211,542
Other income and expense		
Interest income	\$11,309	\$17,389
Other income	\$77,949	\$70,461
Gain (Loss) on sale of fixed assets	(8,771)	\$9
	\$80,487	\$87,859
Provision for income taxes		
Current income taxes	\$1,043,287	\$489,773
Deferred income taxes	\$1,264,287	\$360,974
Net earnings (Loss) for period	\$1,039,000	\$660,704

Produce annual-report quality output everyday.

Letting you easily move 1-2-3 macros into SuperCalc5 and back again. Even toggling between menus is a snap for SuperCalc5.

But not for Excel®

Which now brings us to the "E" word. Unlike Excel, SuperCalc5 runs on all IBM®

Microsoft. IBM is a registered trademark of International Business Machines.

Circle 64 on Reader Service Card

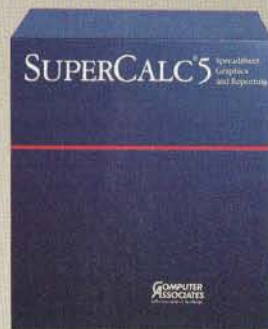

COMPUTER ASSOCIATES
Software superior by design.

Mouse Features 40 Programmable Keys

PowerMouse combines the functions of a mouse with the utility of a programmable calculator. It has 40 programmable keys, and you can program up to 240 functions.

The PowerMouse is designed to work with Lotus 1-2-3 with preprogrammed tables, for example, but also works with other spreadsheets, desktop publishing software, and hardware design programs.

You can define a row or column of numbers, or a section of a row or column, and move it, copy it, or even highlight it. Keys such as Row, Copy, Column, and others speed up the functions even more, because the programmed buttons in the PowerMouse replace keyboard and mouse click sequences.

PowerMouse works with the IBM PC and compatibles and most graphics adapters. Simply connect it to your computer through the serial port and run the TSR software.

The encoding is opto-mechanical with 200-dpi resolution. Tracking speed exceeds 800 mm per second.

Price: \$195.

Contact: ProHance Technologies, Inc., 1558 Siesta Dr., Los Altos, CA 94022, (800) 345-9111; in California, (415) 967-5679.

Inquiry 1137.

SCSI488 for Bidirectional Data Communications

The SCSI488 is a smart peripheral that bridges SCSI and IEEE 488 interfaces for bidirectional communications at data transfer rates of 800K bytes per second.

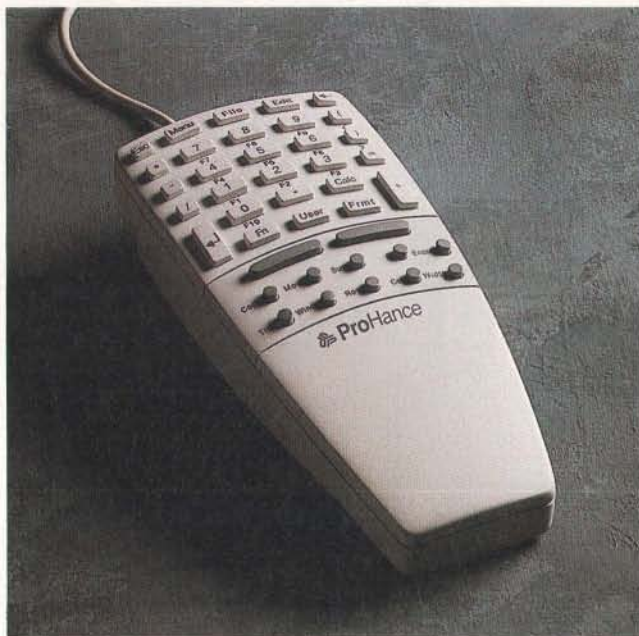

PowerMouse can be programmed with 240 functions.

This speed is achieved with a microprocessor in the SCSI488 that converts data between the different protocols. A high-speed data channel within the unit bypasses the microprocessor during block data transfers.

As a SCSI-to-IEEE 488 instrument controller, one SCSI488 on your SCSI port can communicate with up to 14 IEEE instruments, peripherals, or other computers that have the IEEE 488 interface.

With the daisy-chaining capabilities of the SCSI controller, you can connect up to seven SCSI488 devices to a single SCSI port on your computer, each controlling 14 IEEE instruments.

You can use the command channel to issue commands to the SCSI488 for control of the SCSI bus, while the data channel allows passage of data to and from the SCSI bus.

Price: \$795.

Contact: Iotech, Inc., 25971 Cannon Rd., Cleveland, OH 44146, (216) 439-4091.

Inquiry 1138.

When Power Fails, RAM Your Data into Memory

UniSaver 100 is a backup power supply that combines the usual standby battery backup with surge protection.

But it also includes a full-length card that plugs into your IBM PC or compatible. When power fails, UniSaver 100 transfers the data in RAM and the actual "state" (e.g., registers and controllers) of the machine into its megabyte of nonvolatile RAM.

If the power failure continues, the UniSaver 100 keeps the system running until its internal battery begins to fail. Then it shuts itself down. When power is restored, the system is returned to the exact point where it was before failure.

Price: \$1195.

Contact: Universal Vectors Corp., 580 Herndon Pkwy., Suite 400, Herndon, VA 22070, (800) 777-7860; in Virginia, (703) 435-2500.

Inquiry 1139.

VideoShow for Your Mac

The latest VideoShow is an intelligent presentation system that lets you capture, edit, combine, and display photographic- and computer-generated images on a Macintosh.

Proprietary MacroVision graphics software combines with a 10-MHz 80186 CPU and 512K bytes of memory that works with your Macintosh computer, software, and monitor. Outputs are analog RGB or TTL-RGB. There's a SCSI port, a parallel port, and a port for connection to General Parametrics' SlideMaker, which is a peripheral for making slides of computer-generated images.

The lowest-priced model, VideoShow Companion, connects to the Mac II, Plus, or SE. It generates 1000 simultaneous on-screen colors and can be manipulated with an optional infrared remote control.

The VideoShow Executive comes with the remote control and features a 1.44-megabyte 3½-inch floppy disk drive. It also includes a Genlock function (for synchronizing with other video equipment), 128K bytes of RAM, composite video output, and an AppleTalk port.

VideoShow Professional can display up to 100,000 colors simultaneously in computer-generated images.

Price: Companion, \$1795; Infrared Remote, \$150; Executive, \$2695; Professional, \$9435.

Contact: General Parametrics Corp., 1250 Ninth St., Berkeley, CA 94710, (415) 524-3950.

Inquiry 1140.

continued



QNX vs. OS/2 UNIX

QNX[®]: Bend it, shape it, any way you want it.

ARCHITECTURE If the micro world were not so varied, QNX would not be so successful. After all, it is the operating system which enhances or limits the potential capabilities of applications. QNX owes its success (over 75,000 systems sold since 1982) to the tremendous power and flexibility provided by its modular architecture.

Based on message-passing, QNX is radically more innovative than UNIX or OS/2. Written by a small team of dedicated designers, it provides a fully integrated multi-user, multi-tasking, networked operating system in a lean 148K. By comparison, both OS/2 and UNIX, written by many hands, are huge and cumbersome. Both are examples of a monolithic operating system design fashionable over 20 years ago.

MULTI-USER OS/2 is multi-tasking but NOT multi-user. For OS/2, this inherent deficiency is a serious handicap for ter-

minal and remote access. QNX is both multi-tasking AND multi-user, allowing up to 32 terminals and modems to connect to any computer.

INTEGRATED NETWORKING Neither UNIX nor OS/2 can provide integrated networking. With truly distributed processing and resource sharing, QNX makes all resources (processors, disks, printers and modems anywhere on the network) available to any user. Systems may be single computers, or, by simply adding micros without changes to user software, they can grow to large transparent multi-processor environments. QNX is the main-frame you build micro by micro.

PC's, AT's and PS/2's OS/2 and UNIX severely restrict hardware that can be used: you must replace all your PC's with AT's. In contrast, QNX runs superbly on PC's and literally soars on AT's and PS/2's. You can

run your unmodified QNX applications on any mix of machines, either standalone or in a QNX local area network, in real mode on PC's or in protected mode on AT's. Only QNX lets you run multi-user/multi-tasking with networking on all classes of machines.

REAL TIME QNX real-time performance leaves both OS/2 and UNIX wallowing at the gate. In fact, QNX is in use at thousands of real-time sites, right now.

DOS SUPPORT QNX allows you to run one PC-DOS application at each computer on a QNX network. With OS/2, 128K of the DOS memory is consumed to enable this facility. Within QNX protected mode, a full 640K can be used for PC-DOS.

ANY WAY YOU WANT IT QNX has the power and flexibility you need. Call for details and a demo disk.

THE ONLY MULTI-USER, MULTI-TASKING, NETWORKING, REAL-TIME OPERATING SYSTEM FOR THE IBM PC, AT, PS/2, THE HP VECTRA, AND COMPATIBLES.

Multi-User	10 (32) serial terminals per PC (AT).	C Compiler	Standard Kernighan and Ritchie.
Multi-Tasking	64 (150) tasks per PC (AT).	Flexibility	Single PC, networked PC's, single PC with terminals, networked PC's with terminals. No central servers. Full sharing of disks, devices and CPU's.
Networking	2.5 Megabit token passing. 255 PC's and/or AT's per network. 10,000 tasks per network. Thousands of users per network.	PC-DOS	PC-DOS runs as a QNX task.
Real Time	4,250 task switches/sec (AT).	Cost	From US \$450. Runtime pricing available.
Message Passing	Fast intertask communication between tasks on any machine.		

For further information or a free demonstration diskette, please telephone (613) 591-0931.

Quantum Software Systems Ltd. • Kanata South Business Park • 175 Terrence Matthews Crescent • Kanata, Ontario, Canada • K2M 1W8

Circle 228 on Reader Service Card

QNX is a registered trademark of Quantum Software Systems Ltd. The UNIX Operating System is a registered trademark of AT&T. IBM, PC, AT, XT and PS/2, PC-DOS and OS/2 are trademarks of International Business Machines. HP and Vectra are registered trademarks of Hewlett-Packard Company.

Develop dBASE Applications for Windows

If you're a developer for dBASE III Plus/IV and Clipper applications, you can use dBFast/Windows to create database applications by using standard dBASE commands and syntax and adding a Windows-style interface. You can run the application under Windows or, using the company's dBFast/Mac program, the Macintosh environment. The program, a stand-alone development environment, includes an interactive editor, compiler, and run-time library.

Language extensions let you create multiple windows, pull-down menus, dialog boxes, buttons, bit-mapped pictures, and other graphics features. Bumblebee Software, the program's developer, reports that dBFast/Windows compiles up to 15 times faster than interpreted dBASE. You use the program to create, compile, and execute programs without leaving dBFast/Windows; when running the application with the compiler, you can run an application without linking it to dBFast/Window's run-time library.

The program supports the Dynamic Data Exchange, which allows you to send and receive data from other Windows applications.

dBFast/Windows works on the IBM PC XT or compatibles and requires Windows 2.0 or higher or Windows run-time version, a hard disk drive, and 640K bytes of RAM. The program supports dBASE III/IV and Clipper commands. **Price:** \$249.

Contact: Bumblebee Software, Inc., 1715 114th Ave. SE, Bellevue, WA 98004, (800) 356-6356; in Washington, (206) 462-0130. **Inquiry 1101.**

Make Your C Code Portable

Codecheck analyzes code for portability between DOS, OS/2, Unix, VMS, and the Macintosh environments.

The expert system lets you modify its rules, allowing you to tailor it for just one platform that you want to port to, or to conform to corporate or individual standards. You can also alter the

program to work in a foreign language.

Abraxas claims Codecheck works on all C compilers. It is available now for DOS-, OS/2-, and Macintosh-based systems. Under DOS, it requires DOS 3.0 or higher with 512K bytes of RAM. The OS/2 version works in both Standard and Extended editions and re-

quires 2 megabytes of system memory. The Mac version requires System 6.0 or higher and 1 megabyte of memory and is compatible with MultiFinder and Finder.

Price: \$295.

Contact: Abraxas Software Inc., 7033 Southwest Macadam Ave., Portland, OR 97219, (503) 244-5253.

Inquiry 1106.

Symbolic Debugger for Motorola's DSP56001

Ariel's BUG-56 is a symbolic debugger designed specifically for PC programmers working with peripherals that use Motorola's DSP56001 digital signal processing chip. The debugger loads a monitor program into the DSP; this monitor then works in concert with the debugger to provide memory, control, and trace functions.

BUG-56 features full-screen symbolic debugging, symbolic breakpoints, tracing, and patch assembly. BUG-56 allows you to place symbols and labels in the DSP's P (program), X, and Y memory spaces.

The menu-driven debugger dynamically updates the DSP register display, and permits you to modify the contents of the registers or memory on the fly as your program executes. For music work, BUG-56 lets you display the signal's waveform.

BUG-56's most powerful feature is its ability to play the signals, either as a dump from a section of memory, or from the DSP's data stream as a program runs.

BUG-56 supports a 43-line mode for EGA and VGA owners. The debugger will also do block transfers from the DSP56001's memory to a PC disk. This lets you build dou-

ble-buffered processing systems or data acquisition to the PC's hard disk drive.

The debugger works with Ariel's DSP56001 boards, including the PC-56 board.

BUG-56 requires about 350K bytes of available RAM and DOS 3.0 or higher.

Price: \$395.

Contact: Ariel Corp., 433 River Rd., Highland Park, NJ 08904, (201) 249-2900.

Inquiry 1103.

Translating in AWK

The PolyAWK developer's toolkit includes MS-DOS and OS/2 ports of the AWK data translation language. The toolkit includes a translator that lets you create and distribute stand-alone executable programs from AWK script files. The translator compiles PolyAWK source code into C and binds it with a run-time version of PolyAWK, resulting in a DOS .EXE stand-alone file.

With the toolkit, you can use PolyAWK to write customized development tools or data conversion utilities with a few lines of code.

The toolkit includes both DOS and OS/2 versions of PolyAWK and requires OS/2 or DOS 2.0 or higher, an IBM PC or compatible, and 256K bytes of RAM.

Price: \$295.

Contact: Polytron Corp., 1700 Northwest 167th Place, Beaverton, OR 97006, (800)

547-4000; in Oregon, (503) 645-1150.

Inquiry 1104.

Paradox, dBASE IV at Your Command

AccSys for either Paradox or dBASE IV are software libraries for programmers who need to modify or build from scratch a database application in C or in QuickBASIC. The program allows you to create, read, write, and update Paradox or dBASE IV files without having to learn the relational database manager's complex internal file format.

AccSys provides a full set of tools to control table files, primary index files, and secondary index files. The stand-alone programs that you write with AccSys create files that you can access from your application or from within Paradox or dBASE IV, the manufacturer reports.

AccSys for Paradox works with versions 2 and 3 and is now available for single-user operation. A multiuser version for Paradox will ship this summer.

Price: AccSys for dBASE IV or Paradox, binary only, \$395 each; binary and source code, \$795 each.

Contact: Copia International Ltd., 1964 Richton Dr., Wheaton, IL 60187, (312) 665-9830.

Inquiry 1102.

continued



INSTANT MAINFRAME. JUST ADD SCO.

Not too long ago, a few dozen people sharing the same programs, resources, and information on a single computer at the same time meant only one thing—a mainframe.

Powerful, big, expensive, and proprietary.

More recently, the same people could be found doing exactly the same things—simultaneously sharing programs, resources, and information—on a minicomputer.

A lot cheaper, a lot smaller, yet powerful enough to do the same jobs. And just as proprietary.

Then along came the latest generation of personal computers.

And now, the same people are more and more likely to be found doing exactly the same things—simultaneously sharing programs, resources, and information—on a PC.

And not a whole officeful of PCs networked together, either, but a single PC powering the whole office at once.

A lot cheaper, a lot smaller, yet still easily powerful enough to do the same jobs. Built to non-proprietary, open system standards that allow complete freedom of choice in hardware and software.

And running the industry-choice multiuser, multitasking UNIX® System V platform that gives millions of 286- and 386-based PC users mainframe power every business day.

The UNIX System standard for PCs—SCO.™

Today, SCO UNIX System solutions are installed on more than one in ten of all leading 386 computers in operation worldwide.

Running thousands of off-the-shelf XENIX® and UNIX System-based applications on powerful standard business systems supporting 32 or even more workstations—at an unbelievably low cost per user. And with such blazing performance that individual users believe they have the whole system to themselves.

Running electronic mail across the office—or around the world—in seconds.

Running multiuser PC communications to minis and mainframes through TCP/IP and SNA networks.

And doing some things that no mainframe—or even DOS- or OS/2™-based PC—ever thought about, such as running multiple DOS applications. Or networking DOS, OS/2, XENIX and UNIX Systems together. Or running UNIX System versions and workalikes of popular DOS applications such as Microsoft® Word, 1-2-3®, and dBASE III PLUS.®

Or even letting users integrate full-featured multiuser productivity packages of their choice under a standard, friendly menu interface.

Today's personal computer isn't just a "PC" anymore, and you can unleash its incredible mainframe-plus power for yourself—today.

Just add SCO.

The SCO family of UNIX System software solutions is available for all 80286- and 80386-based industry-standard and Micro Channel™ computers.

UNIX is a registered trademark of AT&T. SCO and the SCO logo are trademarks of The Santa Cruz Operation, Inc. Microsoft and XENIX are registered trademarks of Microsoft Corporation. OS/2 and Micro Channel are trademarks of International Business Machines Corporation. 1-2-3 is a registered trademark of Lotus Development Corporation. dBASE III PLUS is a registered trademark of Ashton-Tate. © 1989 The Santa Cruz Operation, Inc., 400 Encinal Street, P.O. Box 1900, Santa Cruz, California 95061 USA. The Santa Cruz Operation, Ltd., Crossley Centre, Hatters Lane, Watford WD1 8YN, United Kingdom, +44 (0)923 816344, FAX: +44 (0)923 817781, TELEX: 917372 sco2246

SCO
THE SANTA CRUZ OPERATION

(800) 626-UNIX (626-8649)

(408) 425-7222

FAX: (408) 458-4227

E-MAIL: ...!uunet!sco!info info@SCO.COM

Circle 250 on Reader Service Card

Power



T5200: 20MHz 386 processor, 2 internal IBM®-compatible expansion slots, VGA gas plasma display with VGA monitor port, 40MB or 100MB hard disk, 2MB RAM standard expandable to 8MB, 1.44MB 3 1/2" diskette drive.

At Toshiba, we're not only committed to making computers more portable, but also to making portables more powerful.

Which is why, in our effort to constantly improve and refine our machines, we've added three new computers to what is already the most complete family of truly portables available.

Each designed to be powerful enough to take on the increasingly complex tasks that face today's sophisticated PC users.

First, the T1600 which weighs under 12 pounds and which is the fastest battery-

powered computer we've ever made.

Second, the T3100e, the successor to our most popular machine—the T3100/20. We've made it over two pounds lighter and a lot faster—we've even added expansion capabilities. About the only thing we didn't add was more size.

T1600: Battery-powered 286/12MHz, coprocessor socket, 20MB hard disk at 27msec, 1.44MB 3 1/2" diskette drive, 1MB RAM expandable to 5MB, detachable backlit EGA compatible LCD, removable rechargeable battery pack.

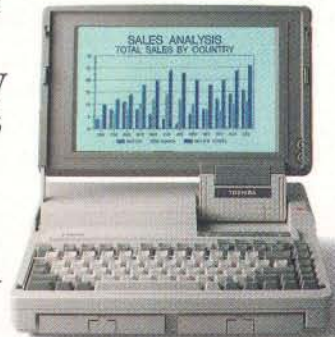

Toshiba is the world leader in truly portable PCs and manufactures a complete line of high quality dot-matrix and laser printers. For more information call 1-800-457-7777. All Toshiba PCs are backed by the Exceptional Care program (no-cost enrollment required). IBM is a registered trademark of International Business Machines Corporation.

Surge.

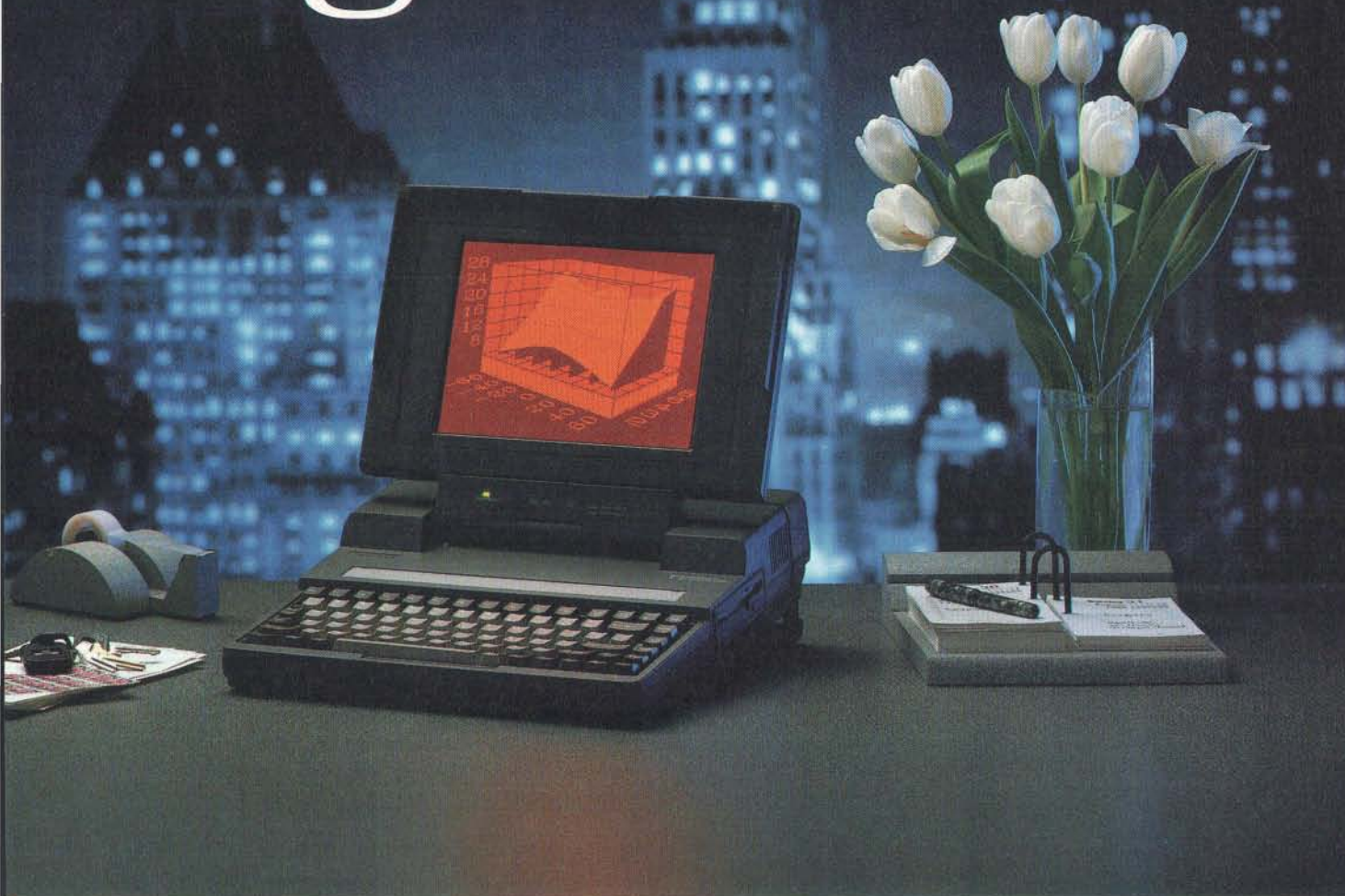

And finally, the T5200, which has enough power to replace virtually any desktop PC.

But we haven't just concentrated on power and portability. We've also constantly looked for ways to make our machines more durable, more reliable, and easier to use—down to the 800 number our customers can call for help with any technical question that might come up.

We figure that's what our users demand.

And it's by anticipating the growing needs of our users that we have continually found ways to make our machines weigh

less and do more. So you can work wherever you want and however you want.

All of which might make it tempting for some people to abandon their desktop for the convenience of portability. Go ahead.

We've given you the power to do it.

T3100: 12MHz 286 with 80287 co-processor socket, internal half-length IBM slot, 20MB hard disk with 27 msec access, 1MB RAM expandable to 5MB, gas plasma display, 1.44MB 3½" diskette drive.



In Touch with Tomorrow
TOSHIBA

Toshiba America Inc., Information Systems Division

Want to save Time, Money,
& Headaches?



GET SUPERSOFT'S
SERVICE DIAGNOSTICS

All the software, alignment diskettes, parallel/serial wrap-around plugs, ROM POSTs and extensive, professional documentation to provide the most comprehensive testing available for IBM PCs, XT's, AT's and *all compatibles* under DOS or Stand Alone. No other diagnostics offers such in-depth testing on as many different types of equipment by isolating problems to the board and chip level.

NEW: SuperSoft's **ROM POST** performs the most advanced **Power-on-Self-Test** available for system boards that are compatible with the IBM ROM BIOS. It works even in circumstances when the Service Diagnostics diskette cannot be loaded.

NEW: 386 diagnostics for hybrids and **PS/2s!**

For over nine years, major manufacturers have been relying on SuperSoft's diagnostics software to help them and their customers repair microcomputers. End users have been relying on SuperSoft's Diagnostics II for the most thorough hardware error isolation available. Now versions of Service Diagnostics are available to save everyone (including every serious repair technician) time, money, and headaches in fixing their computers, even non-IBM equipment.

- | | |
|--|-------------------------------------|
| All CPUs & Numeric Co-processors | All Color Graphics & Monochrome |
| System Expansion & Extended Memory | Monitors |
| Floppy, Fixed & Non-standard Disk Drives | Parallel & Serial Ports |
| Standard & Non-standard Printers | Mono, CGA, Hercules & EGA |
| System Board: DMA, Timers, Interrupt, | Adapters |
| Real-time Clock & CMOS config. RAM | All Keyboards & the 8042 Controller |

Join the ranks of XEROX, NCR, CDC, SONY, PRIME, ... who have bundled SuperSoft's diagnostics with their microcomputers at no risk because of our 30 day money back guarantee.

Service Diagnostics for PC, PC/XT, and compatibles only	\$169
Alignment Diskette for PC, PC/XT and compatibles (48 tpi drives)	\$ 50
Wrap-around Plug for PC, PC/XT and compatibles (parallel and serial)	\$ 30
Service Diagnostics for AT and compatibles only	\$169
Alignment Diskette for AT and compatibles (96 tpi drives)	\$ 50
Wrap-around Plug for AT (serial)	\$ 15
ROM POST for PC, PC/XT and compatibles only	\$245
ROM POST for AT and compatibles only	\$245
Service Diagnostics: The KIT (Includes all of the above—save \$502)	\$495
Service Diagnostics for 386 or V2, V30, or Harris, etc. (please specify)	\$195
Diagnostics II is the solution to the service problems of users of all	
CP/M-80, CP/M-86 and MS-DOS computers	\$125
ROM POST for PS/2 and compatibles only	\$245
Alignment Diskette for PS/2 and compatibles (3.5 inch)	\$ 50

To order, call 800-678-3600 or 408-745-0234
FAX 408-745-0231, or write SuperSoft.

your microcomputer repair solution

SuperSoft

FIRST IN SOFTWARE TECHNOLOGY P.O. Box 611326, San Jose, CA 95161-1326 (408) 745-0234 Telex 270385

SUPERSOFT is a registered trademark of SuperSoft, Inc.; CDC of Control Data Corp.; IBM PC, AT & XT of International Business Machines Corp.; MS-DOS of MicroSoft Corp.; NEC of NEC Information Systems, Inc.; PRIME of PRIME INC.; Sony of Sony Corp.

WHAT'S NEW

SCIENCE AND ENGINEERING

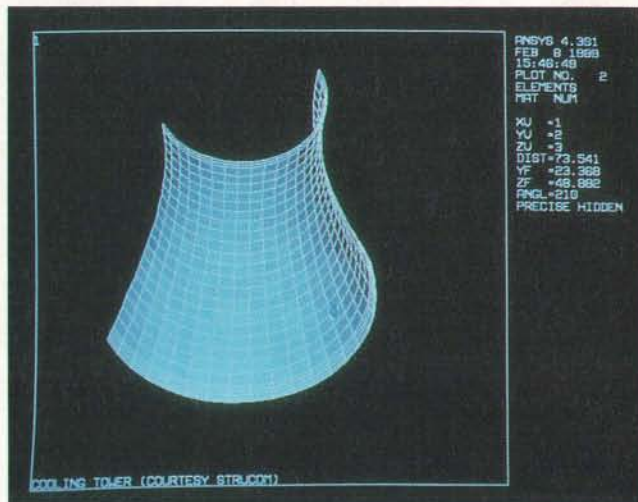

This Ansys-PC/Intro/Lin element display of a power plant cooling tower is made up of 520 quadrilateral shell elements and 140 three-dimensional elastic beam elements.

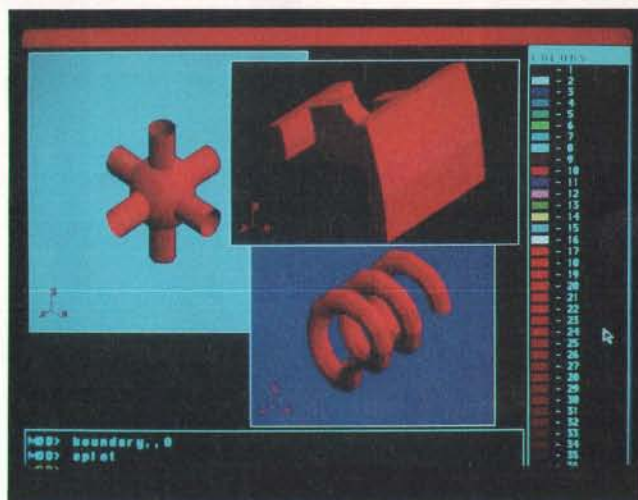

Cosmos/M provides finite-element-analysis capabilities for the Mac II.

Two from the
Finite Front

In recent months we've seen scads of announcements of new and updated finite-element-analysis programs. Here are two: one for the PC and one for the Mac.

Ansys-PC/Intro/Lin is an introductory version of the Ansys-PC/Linear program. It gives you a sampling of the effect that finite-element analysis will have on

your product development.

The program lets you perform static and modal analysis in one, two, or three dimensions. The element library contains 16 elements, including beams and pipes, shells, and three-dimensional solids. The program has a wavefront of 200 and a problem size of up to 10,000 nodes, so you can use the program to model and analyze substantial structures, according to Swanson.

Most of the preprocessing capabilities found in the Ansys

continued

IN ALL FAIRNESS, YOU SHOULD READ WHAT ASHTON-TATE® IS SAYING BEFORE YOU PURCHASE ORACLE.

Ashton-Tate Fights SQL Bugs

Same Query Run Twice Can Result in Different Replies

Ashton-Tate last week acknowledged that the Structured Query Language (SQL) portion of dBASE IV can produce inconsistencies and inaccurate results.

The crux of the SQL problems lies with three anomalies that occur when data is structured in a specific way, according to Knox Richardson, a spokesman for the Torrance, Calif., firm. As a result, the same query run two different times can result in two different replies, for example, or a query

can retrieve incomplete information from the database. (See Chart, Page 8.)

Ashton-Tate does not plan to issue a diskette to fix the problem; it is, however, offering work-around solutions to users through its support lines and bulletin board, and on CompuServe, Richardson said.

Though Ashton-Tate is characterizing dBASE IV's SQL problems as "minor" and confined to specific circumstances, database experts claim their impact is more serious.

"The SQL in dBASE IV is unstable, unreliable and unpredictable," said Richard Finkelstein, president of Performance Computing Inc., a database consulting firm in Chicago.

"I don't see how anyone can use it," he added. "They'd have to know the answer to the SQL query ahead of time."

Surprisingly, the majority of dBASE users were unfazed by dBASE IV's SQL glitches.

"The drawbacks in SQL are an

See DBASE Page 8

PC Week, January 9, 1989

Oracle developed the first commercial SQL database over 10 years ago.

And the first SQL database for the PC over 4 years ago.

It's called Professional ORACLE®.

It has the most up-to-date, most powerful and most complete set of application development tools available.

Like SQL*Forms® SQL*ReportWriter.™ SQL*Menu® And SQL*Plus®.

It's based on ANSI standard SQL and runs on PCs, minis and mainframes.

And it works.

To order Professional ORACLE for the PC, call 1-800-ORACLE1, ext. 4947.

It's \$1,299, and comes with a 30-day, money-back guarantee.

ORACLE®

Compatibility • Portability • Connectability

UNIVERSALLY ACKNOWLEDGED TO WORK JUST FINE.

RAIDS™

works the way you think.

Rapid Application Development System

We take you from Concept to Prototype to Finished Program to Demo to Tutorial

Read our little scenario and check off where appropriate:

<p>"So, Your says: "I need a:</p> <p><input type="checkbox"/> Boss <input type="checkbox"/> Client <input type="checkbox"/> Market</p> <p><input type="checkbox"/> Program <input type="checkbox"/> Prototype <input type="checkbox"/> Demo <input type="checkbox"/> Tutorial <input type="checkbox"/> Presentation <input type="checkbox"/> All The Above</p>	<p>FAST</p>	<p>"Oh, and one more thing, I need to:</p> <p><input type="checkbox"/> Make as many copies as I want with no license fees</p>
<p>"with:</p> <p><input type="checkbox"/> Nested Menus <input type="checkbox"/> Pop-up windows <input type="checkbox"/> Pull-down Menus <input type="checkbox"/> Light Bars <input type="checkbox"/> Original User Interface <input type="checkbox"/> Music</p>	<p>RAD</p>	<p>"And:</p> <p><input type="checkbox"/> No screen in front promoting the product it was developed in.</p> <p><input type="checkbox"/> Free 800 # telephone support</p>
<p>"Oh, and in the prototype, demo, and tutorial could you make it:</p> <p><input type="checkbox"/> Interactive <input type="checkbox"/> Self Running <input type="checkbox"/> Both</p>	<p>EASY</p>	<p>"Oh, and just one more thing, I'd like to use the screens from the prototype in the program we're writing in:</p> <p><input type="checkbox"/> C <input type="checkbox"/> Basic <input type="checkbox"/> Pascal <input type="checkbox"/> dBase <input type="checkbox"/> Clipper</p>
<p>"And it needs:</p> <p><input type="checkbox"/> User Input <input type="checkbox"/> Simulated Report Generation <input type="checkbox"/> Active Screen Areas for User Input <input type="checkbox"/> Dialogue Boxes <input type="checkbox"/> Variable Math Calculation <input type="checkbox"/> GO SUB Routines <input type="checkbox"/> and much more</p>	<p>NEW</p>	<p>"And the routines should also do:</p> <p><input type="checkbox"/> Screen Handling <input type="checkbox"/> File Handling <input type="checkbox"/> Mouse Support <input type="checkbox"/> Serial Port Control</p>

*"And could I have that in two days please?"
Sound familiar?"*

No Problem, if you've got **RAIDS!**

COMPLETE SYSTEM: \$299.95
Demo Available

To Order or For Product Information Call
1-800-777-1437



GENESIS
GENESIS DATA SYSTEMS
8415 Washington Place N.E.
Albuquerque, NM 87113 (505) 821-9425

WHAT'S NEW

SCIENCE AND ENGINEERING

program are included in this introductory version. Parametric language is available for user-specified parameter values. A database language is also included, which lets you manipulate model data.

The program runs on the IBM PC with 640K bytes of RAM, a 20-megabyte hard disk drive, DOS 3.1 or higher, and a math coprocessor. It is also available in a Mac II version.

Price: \$2000.

Contact: Swanson Analysis Systems, Inc., Johnson Rd., P.O. Box 65, Houston, PA 15342, (412) 746-3304.
Inquiry 1111.

Contact: Structural Research and Analysis Corp., 1661 Lincoln Blvd., Suite 100, Santa Monica, CA 90404, (213) 452-2158.
Inquiry 1112.

NKR Research Offers Languages Under A/UX

NKR FORTRAN is a globally optimizing compiler that offers Unix integration through the use of C calling conventions. It runs under A/UX on the Mac Ix.

NKR FORTRAN includes VAX/VMS FORTRAN extensions and conforms to ANSI 78 and military 1753 standard. The optimizer was built exclusively for FORTRAN, according to NKR, and the optimizer and library modules were built exclusively for NKR FORTRAN.

The company also recently began shipping NKR BASIC, which it reports is the only BASIC running under A/UX. The language comes in both compiler and interpreter versions, which you can use separately or as a matched set. They conform to the ANSI X3.113 and the European ECMA-116 standards for the BASIC language. The BASIC interpreter includes a Help facility and a debugger. The compiler produces native machine code on A/UX.

NKR's compilers are written in C and use Unix calling conventions.

Price: FORTRAN, \$495; BASIC compiler and BASIC interpreter, \$395 each (25 percent discount if purchased as set).
Contact: NKR Research, Inc., 4040 Moorpark Ave., Suite 209, San Jose, CA 95117, (408) 249-2612.
Inquiry 1108.

Cosmos/M, the finite-element-analysis program for the IBM PC, now runs on the Mac II and can solve problems of up to 25,000 degrees of freedom. The program takes advantage of the 256 colors available on the Mac II to generate color-filled stress and thermal-contour plots.

Cosmos/M also solves nonlinear problems by using an incremental solution technique and by using isoparametric elements that increase accuracy where boundaries are curved or where high stress variations exist, according to SRAC. The program also offers nonlinear buckling analysis, a capability that the company reports has previously been available on only mainframes.

Unlike other Mac II finite-element-analysis programs, Cosmos/M was written specifically for the PC environment, which, the company claims, makes it much more efficient than programs ported down from mainframes. The program is divided into modules that you can load into memory and remove as needed.

File I/O routines are written in Mac II assembly language.
Price: \$2995.

continued

NEW!

Monitor and Control From Your PC

SOLUS™ Personal Control Computer™

The intelligent, stand-alone SOLUS™ computer is powerful enough for industrial and research applications, yet inexpensive and simple enough for school and home use.

- Easy to "program" and use
- Powerful real-time graphics
- 30 Digital/Analog I/O channels
- Interfaces to PC via RS-232 or modem

Call your SOLUS representative now. And control your world!

Only
\$895
each

Host Software
Additional
VISA/MC/AMEX
accepted



(800) 247-5712
In Oregon and outside U.S.
(503) 635-3966

TMI inc.
4000 Kruse Way Place, 2-120
Lake Oswego, OR 97035
FAX (503) 635-3004

School Discounts Available

The End of Plain Vanilla PC Graphics

More Vibrant Colors and Higher Resolution. Any Way You Scoop it.

Now, Genoa dishes up more ways to eliminate the monotony of monochrome. Or the lifeless look of low-res color. With a brilliant line-up of IBM compatible graphics cards, designed to please any palate.

The creme de la creme in performance. For CAD and desktop publishing, get the ultimate in high performance: SuperHGA™, with an on-board graphics processor. It puts ultra hi-res images on any IBM 8514-compatible display with blazing speed. At 1024 x 768

resolution with 256 on-screen colors from a palette of 16 million.

Your choice of flavors, a la any mode. Genoa serves up a full menu of SuperVGA™ and SuperEGA cards. All of which extend the IBM standards—with VGA resolutions of up to 1024 x 768 in 16 colors in both non-interlaced and interlaced modes, and up to 800 x 600 in 256 colors.

The pint-size combo package. For sparkling color and monochrome graphics in one economical half card, choose our SuperSpectrum™. It's 100% CGA, MDA and Hercules compatible, with double scanned CGA for quality game images. Plus 132-column text for full spreadsheets.

So if your graphics board is producing nothing but "board-
dom," go to your dealer today and order some Genoa graphic excitement. Call (408) 432-9090 today. Or write Genoa Systems Corporation, 75 E. Trimble Rd., San Jose, CA 95131; FAX (408) 434-0997, London 44-01-225-3247; Taiwan 886-02-776-3933.

IBM is a trademark of IBM Corp. Hercules is a trademark of Hercules Technology. SuperHGA, SuperVGA 16-bit Graphics Adapter, SuperVGA, SuperEGA HiRes and SuperSpectrum are trademarks of Genoa Systems Corp.

Circle 317 on Reader Service Card

Insist on
Genoa Value.
GENOA



Right Now. Guaranteed!*

Yes, we can ship your new ZEOS® '286 or '386 today! We've built up an extra supply of the hottest selling computers in America. The celebrated ZEOS 286-12 and PC Magazine's Editors Choice—the ultra fast ZEOS 386-16.

Take your pick now for immediate delivery. These are both *complete*, genuine ZEOS Zero-Wait state systems. Both include an ultra-fast Seagate hard drive and all the other goodies. And they're ready to ship. **Right Now.**

Here's how it works. We have these extra systems pre-built and ready to ship. They include both High Resolution Monochrome and VGA systems. While supplies last, we will ship either of these systems to you *the day you order* subject to these conditions:

1. Your order must be received by IPM Central Time.
2. Credit Cards are subject to credit card authorization.
3. Orders must be for our standard 286-12MHz system or 386-16MHz system, either monochrome or VGA. Any other systems or upgrades are custom built and will take slightly longer.

***Our Guarantee to You:**

If we fail to ship your system under the conditions outlined, we will ship it *at our expense* as soon as it is ready. All systems are fully burned in and tested. Each system includes our 30 day Money Back Guarantee and One Full Year Limited Warranty. *Toll Free* technical support and Express Parts Replacement are included too!

This offer is good only as long as these pre-built

Comput

Complete ZEOS 12MHz '286 with 32MB Hard Drive!

Only \$1,395

For VGA color add \$595

Standard Features Include:

- 80286-12 CPU, 6/12MHz Dual Speed keyboard/hardware selectable. Reset and Turbo buttons right up front.
- Zero-Wait State DRAM, 512K expandable to 4MB on the mother board (16MB System Total). EMS Capability on board.
- Fast 32MB Seagate 138R Hard Drive with auto-park, 1.2MB Floppy Drive.
- Ultra high speed Hard/Floppy controller. 1:1 interleave, 800 KB/sec transfer rate.
- Genuine Hercules® (Yes, Hercules!) Brand graphics card. High-Res Amber Display with Tilt/Swivel Base.



- ZEOS Enhanced 101 Key Keyboard with our Pleasant Tactile/Click Feel.
- Serial and Parallel Printer Ports.
- Clock/Calendar with Battery Backup.
- 6-16 and 2-8 bit expansion slots.
- 80287 support, up to 12 MHz.
- Heavy Duty Case Complete with Security Lock and LED indicators.

FREE Shareware Disks Too!
25 Software Programs Included
Every system will include 5 ready to run Shareware programs on free disks. Included are programs for Word Processing, Spread Sheets, Educational, Financial, Business, Games and more. With Shareware you can try the programs first before you register them with the author. What a great idea!

Performance Comparisons using PC Labs Benchmark Series Release 4:

	NOP	80286 Instruction Mix	Floating Point Calculation	Conventional Memory
ZEOS 286/12 Desktop	2.81	4.78	18.84	0.72
IBM PC AT (8MHz)	4.23	8.96	35.60	1.32
IBM PS/2 Model 50	3.35	7.20	28.34	1.05

systems remain in stock; please give us a call to verify availability. This offer does not apply to other ZEOS systems or custom configurations.

Immediate shipment is only part of the story.

ZEOS builds Rock Solid computers. That's why we offer you our 30 Day Money Back Guarantee, Toll Free technical support and Full One Year Limited Warranty. Compare that to the others. Then compare performance.

Performance is what ZEOS is all about. If you're buying a computer you may as well buy the fastest. The ZEOS 286-12 is *the fastest* in its class. It features true Zero-Wait state operation with speeds close to many 386 systems!

Or select the ZEOS 386-16. The Editors of *PC Magazine* did. In fact they selected the ZEOS '386 as

Editors Choice. And is it ever a screamer. As the *PC Magazine* said, "This ZEOS 386-16 blows away every other computer..." Another *PC Magazine* editor said "Don't pass up the ZEOS... solid construction, flexible design and escape-velocity performance make it a top flight choice."

PC Resource Magazine put it this way "ZEOS... provides quality comparable with the IBM or Compaq and does so for about 70% of the cost." *Personal Computing* simply says "The best value we've come across so far."

We couldn't have said it better ourselves.

And these are the machines that we have ready to ship to you *right now*. Rock solid block buster ZEOS machines with quality and performance that is, in a word, *Guaranteed*. Order now by calling 800-432-5891.

ers Now! SM

Complete ZEOS 16MHz '386 with 80MB 28ms SCSI Drive!

Only \$2,495
For VGA color add \$595

Standard Features Include:

- Genuine 32-bit Intel 80386-16MHz CPU.
- High speed Zero-Wait 64K SRAM CACHE.
- 1MB of Zero-Wait DRAM Expandable to 16MB system total.
- Fast 80MB, 28ms SCSI Seagate Hard Drive, 1.2MB Floppy Drive.
- Ultra high speed Hard/Floppy SCSI controller.
- Genuine Hercules® Brand graphic card. High-Res Amber Display with Tilt/Swivel Base.
- 101 Key ZEOS Tactile/Click keyboard.



Performance Comparisons using PC Labs Benchmark Series Release 4:

	NOP	80386 Instruction Mix	Floating Point Calculation	Conventional Memory
ZEOS 386/16 Desktop	2.10	3.58	13.62	0.58
IBM PS/2 Model 70-E61	2.09	4.11	16.14	0.77
Compaq Deskpro 386/16	2.09	4.12	15.47	0.75



- High speed Serial and Parallel Ports.
- 1-32, 5-16 and 2-8 bit slots.
- 80387 math co-processor support.
- ZEOS 5-bay case with security lock and LED indicators.

Order Now Toll Free
800-423-5891

FAX Orders Dial: 612-633-2310
In Minnesota Call: 612-633-4591
MasterCard, VISA and COD
Open days, evenings and weekends
Se habla Español.
ZEOS International, Ltd.
530 5th Avenue, N.W.
St. Paul, MN 55112 USA



24-bit Color with QuickCapture

ColorKit works with Data Translation's 256-gray-level frame-grabber board for the Mac II to capture, display, and store images with 24-bit color.

With the QuickCapture board, you capture images from RGB video cameras. The ColorKit software then grabs separate RGB signals in real time. You can adjust the focus on the Mac II screen as you watch and then tell the software to acquire the image, which it does in less than a second, according to Data Translation.

Since the Mac II uses the standard 8-bit color display, which can show only 256 colors at a time (24-bit color can have up to 16.7 million colors), the software offers you a choice of color mapping routines: uniform, biased, dithered, adaptive, and monochrome.

ColorKit is compatible with PhotoMac, PixelPaint, and Studio/8 paint programs. Data Translation reports that the program will work with any previously stored 24-bit color image.

Price: \$295.

Contact: Data Translation, 100 Locke Dr., Marlboro, MA 01752, (800) 522-0265; in Massachusetts, (508) 481-3700.

Inquiry 1119.

Rotate AutoCAD Files

SpinCAD lets you rotate, translate, and scale two- and three-dimensional AutoCAD .DXF files in real time.

The program runs on the IBM PC with at least 256K bytes of RAM, DOS 2.1 or higher, and a CGA, EGA,



Image created with Data Translation's ColorKit and Avalon's PhotoMac on the Mac II.

VGA, or Hercules card.

Price: \$140.

Contact: Aptech Systems, Inc., 26250 196th Place SE, Kent, WA 98042, (206) 631-6679.

Inquiry 1121.

Graphics for the Database Developer

Originally, dGE was created to add graphics capabilities to dBASE II. Version 2.0 adds graphics to dBASE II Plus, dBASE IV, Clipper, FoxBASE Plus, Quicksilver, dBFast, Eagle, and C compilers.

Graphing functions include pie charts, bar graphs, high-low-close, polar, time series, Cartesian, polyvector, and more. The program is capable of performing statistical functions as well. You can also mix and overlay as many graphs as you want on a page.

To run dGE, you load a 30K-byte TSR graphics kernel into memory. The dGE commands are added to the application by a linkage module.

You need an IBM PC with DOS 2.0 or higher. The program also supports Windows, Pinnacle reports. And you can use CGA, EGA, VGA, or Hercules graphics.

Price: \$195.

Contact: Pinnacle Publishing, Inc., P.O. Box 1693, Tacoma, WA 98401, (206) 383-4396.

Inquiry 1120.

Mechanical Design with FastCAD

Mechanical Design Environment (MDE) is a set of integrated macros, menus, external procedure modules, and symbol libraries that work with FastCAD to speed up mechanical drafting and layout.

MDE includes multiple dimensioning modes and formats, ANSI Y-14.5 tolerancing symbols, libraries of standard fasteners, and parametric drawing of common components.

FastCAD lets you perform associative ordinate dimensioning, associative radii and diameters with optional text, scaled dimensions for expanded views, infinite horizontal and vertical construc-

tion lines, and a variety of standard symbols.

MDE works with FastCAD 2.05 or higher on the IBM PC with a math co-processor.

Price: \$395.

Contact: Evolution Computing, 437 South 48th St., Suite 106, Tempe, AZ 85281, (602) 967-8633.

Inquiry 1122.

Upgraded Generic CADD for the Mac

Generic CADD Level 1 version 1.1 includes a Mac-to-MS-DOS translator utility, the ability to save files in PICT or EPS format, the ability to open a PICT file without using the Clipboard, a select-all capability, and new design capabilities.

Drawings produced with CADD Level 1 have floating-point precision to 16 decimal places. Drawing tools include points, lines, rectangles, regular polygons, circles, arcs, ellipses, Bézier and spline curves, and text. You can place objects on 256 layers, rotate them to any angle, and change their scales. You can also import files from other applications as PICT files, or export as PICT or EPS files.

Generic CADD Level 1 version 1.1 runs on the Mac Plus, SE, or II with at least 1 megabyte of RAM. A math co-processor is recommended.

Price: \$149.95.

Contact: Generic Software, Inc., 11911 North Creek Pkwy. S, Bothell, WA 98011, (800) 228-3601; in Washington, (206) 487-2233.

Inquiry 1123.

continued

Hands down, the best selling most compatible graphics tablet you can buy.



Desktop Publishing

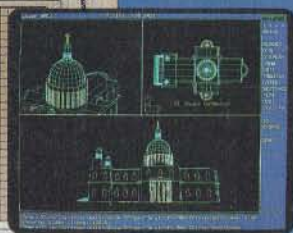

CAD

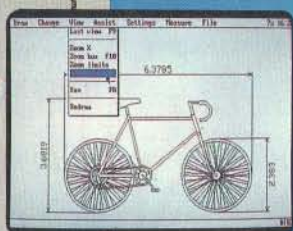

Universal Mouse Emulator™



Drawing / Tracing



Microsoft® Windows

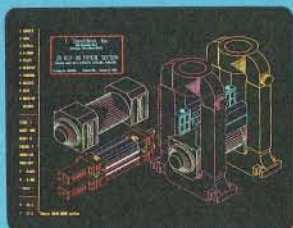

CAM

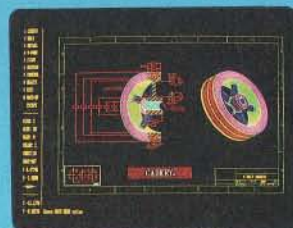

CAE

SummaSketch[®] is the world's best selling tablet because it's filled with "Plus's". Like full IBM connectivity with the PC, AT and PS/2. Plus full Microsoft[®] compatibility through a Universal Mouse Emulator[™]. Plus a separate tablet driver for Microsoft Windows. Plus a two-year warranty. Add that to our standard features — like high resolution and accuracy with the most software compatibility — and you have the tablet with all the Plus's. The 12" × 12" SummaSketch Plus.

New 18" × 12" Version. Now you can get all these great features in our larger SummaSketch[®] Professional tablet. All the Plus's, plus more active area to work with!

 **Summagraphics.**

Seymour, CT 06483 • (203) 881-5400

Circle 261 on Reader Service Card (DEALERS: 262)

FREE! \$245 TEMPLATE.

Your choice: AutoCAD[®], VersaCAD[®], CADKEY[®] or Microsoft[®] Windows tablet template, free. Details inside SummaSketch Plus and SummaSketch Professional boxes.

Send me more information on the AutoEase template offer and on SummaSketch tablets.

Type of industry: _____

Type of application: _____

I'm interested in OEM information.

Name: _____ Title: _____

Company: _____

Address: _____

City: _____ State: _____ Zip: _____

Mail to: Summagraphics Corporation
60 Silvermine Road
Seymour, CT 06483

© 1988 Summagraphics Corporation. All rights reserved.

THERE ARE FOUR WAYS TO MEASURE THE SPEED OF A LAN.



Ours only wins in three of them.

1. How fast does it install.

We have no competition in this category. LANLink 5X installs in about fifteen minutes, and it doesn't take a technician to do it. Since LANLink 5X uses standard parallel or RS-232 serial ports, installing a network means little more than connecting the cable and loading the software.

With hardware LANs, installation can easily take two days—one to set it up and one to tweak it. And it also takes someone who really knows what he's doing. That is, someone expensive.

2. How fast does it transmit.

Okay, this is the category we don't win; the hardware LANs are generally a little quicker. At least, they are under optimal conditions, which is how they rate themselves.

But LANLink 5X is pretty quick, too. At half a megabit per second, it's way out ahead of any other software LAN, and right at the heels of the hardware types. Which, of course, are far more expensive.

3. How fast does it maintain.

The real cost of a network is not so much the initial price as it is the continuing outlay for maintenance—adapting it to changing needs. That's something LANLink 5X does practically on its own.

Running under PC-MOS/386™ or PC-DOS, it turns your server PC into a multi-tasking controller, driving a truly expandable LAN that is easily and quickly upgradable.

A hardware LAN, on the other hand, becomes obsolete as new technology is introduced. And, to keep the network up and running as applications change, you need the attentions of a technician, on a continuing basis. A very well-paid technician.

4. How fast can you pay for it.

Now we've arrived at the bottom line, where LANLink 5X is toughest to beat. You can install a five-user LANLink network for about the same cost as the LAN board in a board-driven network. On top of that, factor in what you save on installation and maintenance time, and the difference is pretty dramatic.

LANLink 5X is available immediately, and it comes with a money-back guarantee. Its price of \$595 includes a server and a satellite module plus the network operating system. Additional satellites are available for \$125.

For complete details on the fastest software-driven network available, call 800-451-LINK.

LANLink 5X. Because three out of four ain't bad.
3577 Parkway Lane, Norcross, GA 30092 (404) 448-5465 FAX (404) 263-6474

LANLINK 5X



THE SOFTWARE LINK

How To Bring Minicomputer Power To Your PC

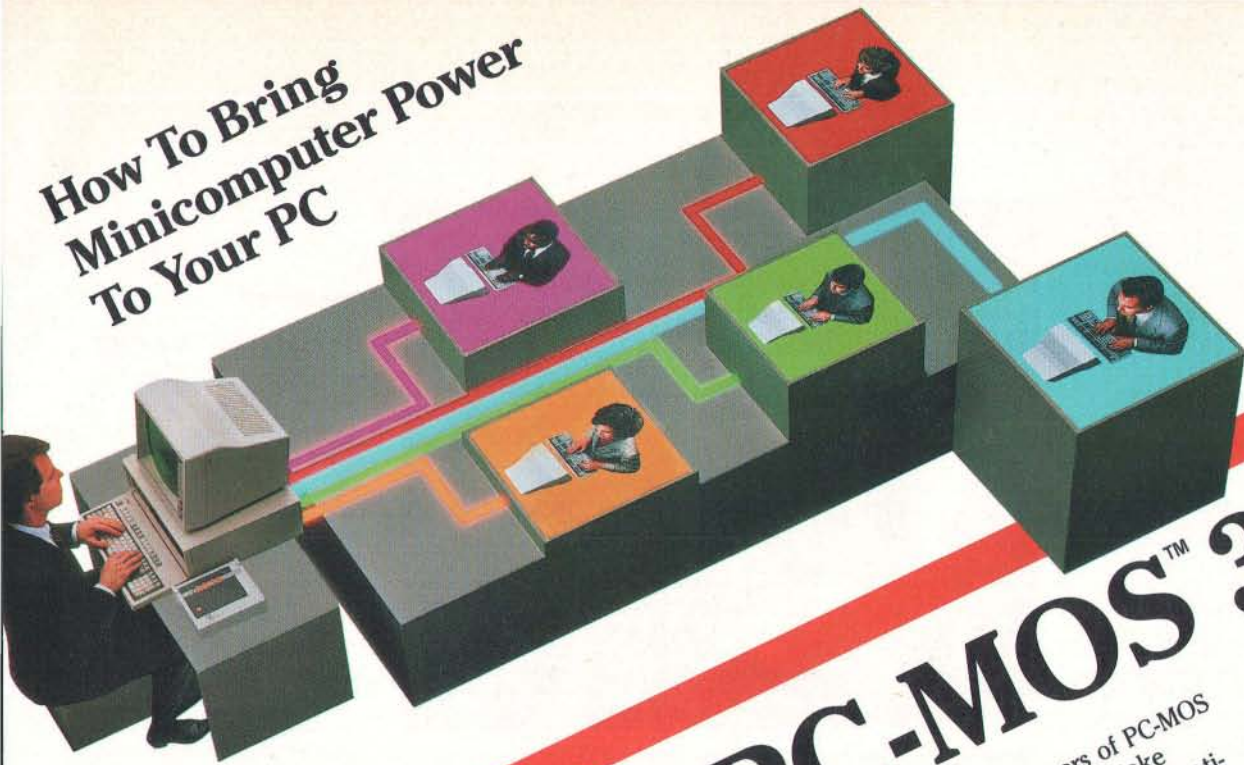

Introducing PC-MOS™ 3.0

A multiuser system no longer means only a mainframe or minicomputer. Today's 386- and 286-based PCs are more powerful than the minicomputers of just a few years ago. And they often provide more desktop power than one person can use effectively.

That's why you need PC-MOS 3.0. It harnesses the power of your 386- or 286-based PC and turns it into a powerful multiuser, multitasking computer. PC-MOS is the multiuser operating system that lets you run popular DOS applications such as Windows™, Lotus 1-2-3™, dBase IV™ or WordPerfect™—without modification. PC-MOS is the perfect solution for a small business or a department of a large company that needs users to easily and affordably share programs, databases or peripherals. It takes full advantage of the hardware's power—and saves you money in the process! For example, instead of replicating PCs, each user can have an inexpensive terminal or monitor that acts like a PC.

DOS Compatibility Means Minimal Training And Support

Since PC-MOS is DOS compatible—unlike UNIX™ or OS/2™—there's no need for users to learn a "new" operating system or be retrained on the application programs they already know. And unlike most LANs, PC-MOS is easy to install and even easier to maintain. No hassle, no expensive wiring and no network management headaches.

There are now more than 100,000 users of PC-MOS worldwide, but if you haven't seen it lately, take another look. We've broadened our base of compatible applications and added multi-level security, faster disk performance and larger task sizes. Version 3.0 also interfaces with Novell LANs, 3270 mainframe communications products and The Software Link's LANLink™ local area network.

Call us today for more information about PC-MOS 3.0 and the location of your nearest multiuser dealer. We'll show you how to easily and affordably turn your PC into a powerful multiuser system.

Terminals and Workstations Supported

Wyse 150™, Link MC5™, Kimtron KT-70™, IBM 3151™, AT&T 605 Business Communications Terminal™, Sun River Cygnal/386™, Video Network Adapter™ and others.



THE SOFTWARE LINK

3577 Parkway Lane Norcross, GA 30092
1-800-451-LINK (404) 448-5465
Fax: (404) 263-6474 Telex: 4996147 SWLINK

PC-MOS and LANLink are trademarks of The Software Link, Inc.
All other products referenced are trademarks of their respective companies.

Your connection to advanced technology

Circle 309 on Reader Service Card (DEALERS: 310)

Lucid 3-D Supports Graphing and Expanded Memory

Version 2.0 of Lucid 3-D now supports three-dimensional graphics, three-dimensional range linking, and expanded memory. It can also directly read and write Lotus 1-2-3's .WK and .WK1 files, as well as dBASE files.

You can do pie, bar, line, and scatter charts in three dimensions, and the program's graph switch feature lets you view data from 25 different perspectives.

Other new features include minimal recalculation and a transpose through the clipboard that handles formulas.

To run version 2.0, you need an IBM PC with 256K



Three-dimensional Lucid 3-D is no longer a TSR program.

bytes of RAM (347K bytes for graphics capabilities). It supports any Microsoft-compatible mouse and IBM-compatible dot-matrix and Hewlett-Packard LaserJet printers.

Price: \$99.95.

Contact: Dac Software, Inc., 17950 Preston Rd., Suite 800, Dallas, TX 75252, (214) 248-0205.

Inquiry 1114.

Database Power for Nonprogrammers

Alpha Software's Alpha Four is a relational database for users who don't know a database programming language but need to build sophisticated applications to manage data. With the program's outliner, you can build an application in the same way you would create an outline with your word processor, using familiar language.

Up to 10 databases can be linked with a common linking field or equation as a single database.

Alpha Four is written in C and is compatible with dBASE III files, Alpha reports. It works on the IBM PC or com-

continued

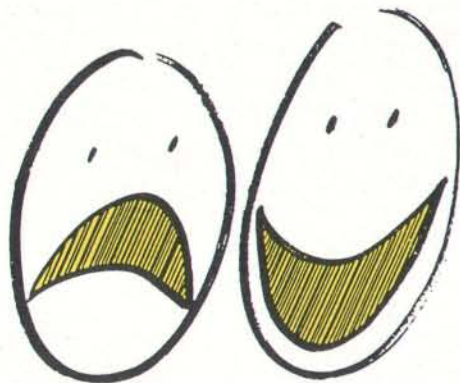

At Barcode Industries we design our products to adapt to our customers' systems. We don't expect our customers to change the way they operate to accommodate us.

That's why we invented the MindReader wedge and then brought out the MiniBar and MaxiBar programmable readers. Our readers interface to over 100 PCs, IBM terminals, compatibles, and cash registers, without requiring any change in the host's hardware or software.

BAR CODES WERE NOT INVENTED TO COMPLICATE YOUR LIFE

Barcode is simplifying life even further with its two latest products:

- ScanPlus is the ergonomic CCD scanner that makes scanning as easy as pointing.
- Planet links together Barcode's products, and any others with RS-232 ports, in a high-speed token-ring network.

Best of all, these products can help you realize the promise of bar coding without the problems. And it's not complicated. Give us a call.

BARCODE





Bring your desktop to life.

You can't breathe life into your ideas if you feel like strangling your computer.

So we've developed a line of powerful, yet delightfully simple, personal computing tools.

*The Mouse that'll work with **any** application, and zoom the cursor precisely to its destination with a mere flick of the wrist.*

ScanMan™ The handheld scanner that'll pop images into any IBM or Macintosh personal computer in seconds.

And Finesse™ The comprehensive publishing

program that's earning a reputation as the easiest to use in its class.

Talk to your dealer about the Logitech Line, and soon you'll be swearing by your computer, not at it.

For your nearest dealer call Logitech at: 800-231-7717

In California: 800-552-8885

In Europe: ++41-21-869-96-56

Circle 159 on Reader Service Card (DEALERS: 160)

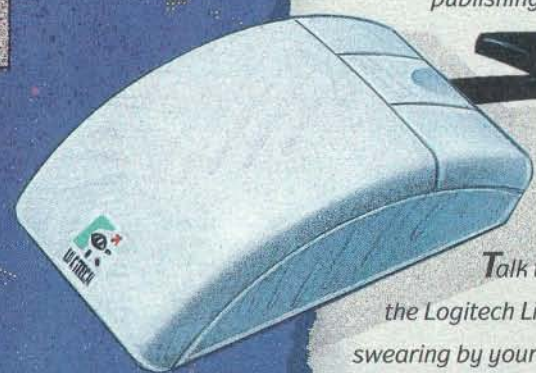

patibles with 512K bytes of RAM and a hard disk drive.

Price: \$549.

Contact: Alpha Software Corp., 1 North Ave., Burlington, MA 01803, (617) 229-2924.

Inquiry 1115.

A Clean Sweep for Mailing Lists

Ever wonder why your name gets so botched on computer-generated letters? If everyone generating those letters used mailing list utilities, our mailboxes would be cleaner places.

Peoplesmith Software has three utilities that help you enter and clean up lists of names.

DynaKey lets you enter

HyperPad Goes DOS

HyperPad is a character-based HyperCard-like software environment for PCs running DOS. HyperPad features the same hierarchy as its cousin, HyperCard, and uses similar objects, tools, and menus.

HyperPad is a configurable, object-oriented environment with a scripting language and built-in functions for painting, drawing, and forms generation.

The scripting language, called HyperScript, is simi-

lar to Apple's HyperTalk, except that HyperPad is character-based rather than graphical.

HyperPad will run on any IBM PC, PS/2, or compatible with DOS 2.1 or higher. It uses 384K bytes of RAM.

Price: \$99.95; limited developer's edition, \$495; unlimited license, \$3000.

Contact: Brightbill-Roberts, 120 East Washington St., Suite 421, Syracuse, NY 13202, (315) 474-3400.

Inquiry 1117.

names and addresses in all caps, with special abbreviations and no punctuation. The program converts what you've entered to whatever format you want it in, such as uppercase and lowercase and expanded abbreviations.

DataLift is a program that takes a database of all caps, strange abbreviations, and inconsistent punctuation and converts it to a list you can use. It's similar to DynaKey, but it assumes that you've imported a list from somewhere

else, rather than keying it in yourself.

The third program, Personator, takes a list of first and last names and splits them into different fields.

Personator will accept up to three suffixes and recognizes last name prefixes like the Mac in MacDonald. The program contains a first-name table with 7000 first names.

All three programs run on the IBM PC with DOS 2.0 or higher and 512K bytes of RAM.

Price: DynaKey, \$199; DataLift, \$149; Personator, \$129.

Contact: Peoplesmith Software, 18 Damon Rd., P.O. Box 384, North Scituate, MA 02060, (800) 777-2460; in Massachusetts, (617) 545-7300.

Inquiry 1116.



Protect the one you love.

Yours is not just any computer. It's your friend. Your confidant. Your business partner. You wouldn't be without it.

But it can happen in a flash. A sudden storm, distant ditch digger, motor, or even a toy metallic balloon can send data-killing, component-killing electric surges and sags smack into your computer. Even knock it out altogether.

It's a matter of time before this happens to you. So protect your friend with Emerson's

new low-cost SW1000 Uninterruptible Power System. Only 2¼ in. high, it fits smartly right under your PC's monitor for less than \$700.

In a brownout or blackout, a battery will instantly take over giving you ten minutes or more to shut down your computer.

Call 1-800-Back-UPS for the Emerson dealer nearest you. Before it's too late.

EMERSON
Computer Power
Computers Won't Run Right
On The Wrong Fuel.

*Limit 1 per customer. Offer expires September 30, 1989. Dealer: For reimbursement, forward copy of sales slip, UPS serial No., and customer name. address and phone number to: Marketing Services, Emerson Computer Power, 3300 S. Standard Street, Santa Ana, CA 92705.

© 1989 Emerson Electric Co.

INTERNATIONAL

96IS-3 Short Takes
Brainstorm, an outline processor for brainstorming a new project

96IS-4 What's New

96IS-52 Writing Macintosh Device Drivers by Joel West and Mark Anderson
With open Macs, knowledge of device drivers is now a necessity



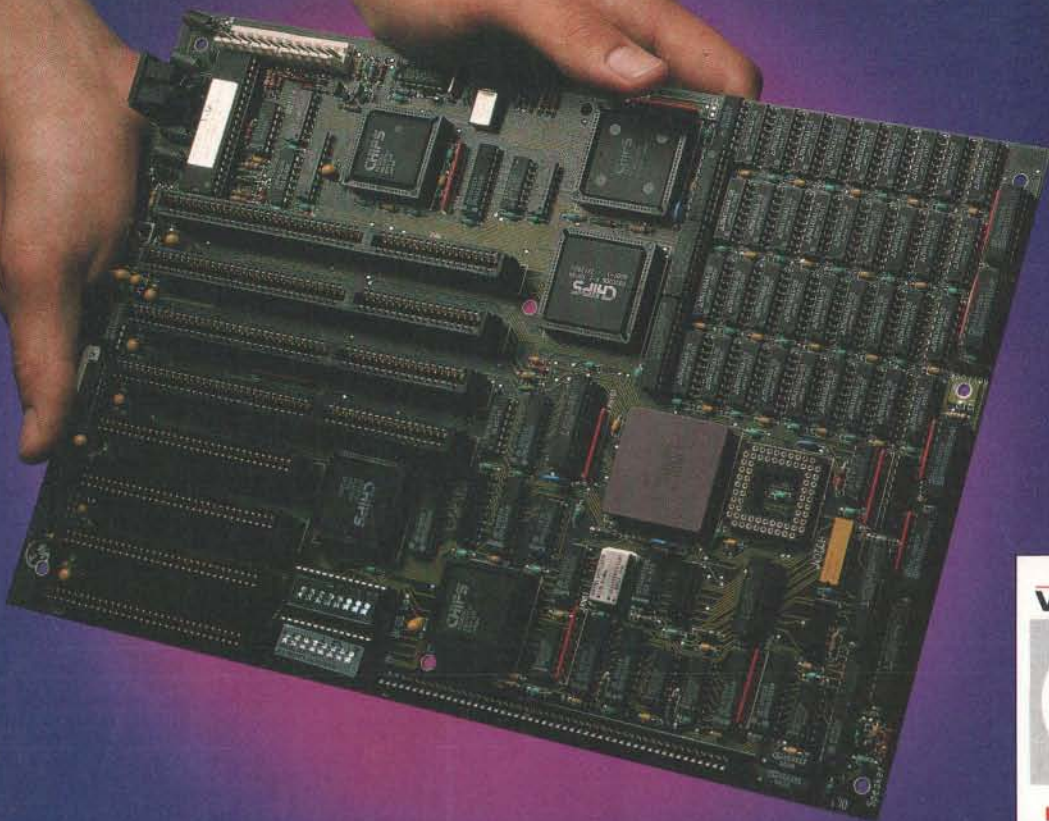

IT Hz SO GOOD!

INTRODUCING HAUPPAUGE'S 33MHz MOTHERBOARD

Do you need the highest network, CAD, or Multiuser performance? With a MotherBoard built to handle 33MHz operation, you can configure the fastest computer on the block!

UNIX/386 and OS/2 Compatible. To ensure a long, fruitful life, our 386 MotherBoards are compatible with the PC/AT (BIOS and I/O) — so you can run the new generation of DOS, OS/2. Our Boards also run Windows/386, UNIX V, DESQview 386, and XENIX/386. Plus, we can add up to 64 Megabytes of 32-bit extended memory. What more could your applications ask for!

Technical Features ■ SX, 16, 20, 25, and 33MHz 80386
■ from 1 to 64 Mbytes of high speed 32-bit 4-way interleaved RAM ■ PC/AT compatible BIOS and I/O system for support of OS/2 and UNIX ■ 64K of 20 nsec static RAM cache on 25MHz and 33MHz boards ■ One 32-bit expansion slot for up to 64 Megabytes of high speed memory.

For more about our products, mail us this coupon.

Yes, send me your product information!

Name _____

Company _____

Address _____

City, State, Country _____

Telephone _____

Mail coupon to West Germany or the U.S.A.

Hauppauge Computer Works, GmbH
Hansaallee 201

4000 Dusseldorf 11, West Germany

Tel: 0211-594320

Fax: 0211-593908

Hauppauge Computer Works, Inc.
175 Commerce Drive,

Hauppauge, New York 11788, U.S.A.

Tel: 01-516-434-1600

Fax: 01-516-434-3198

If your computer feels slow, we know where it hertz.
Call for a fast cure: In the US: 516-434-1600.
In Europe: 49-211-594330.

Hauppauge Computer Works Your 386 Supplier

SHORT TAKES

INTERNATIONAL

BYTE editors' hands-on views of new products

An Outline Processor for Brainstorming a New Project

Brainstorm can stake its claim as the world's first commercial outline processor—Brainstorm Software first launched it under the CP/M-80 operating system in 1982, several months before the emergence of the U.S. product ThinkTank. Several years ago, Brainstorm was updated for the IBM PC running under DOS, but the company revised the program again, and the latest version is a TSR program. Making it a pop-up utility has enhanced its usefulness enormously.

An outline processor is a tree-structured text editor. It lets you jot down a list of ideas and then expand on them by making each idea a headline with its own list of sub-ideas. For example, you can use an outline processor as a notepad for brainstorming a new project (hence the name) or for quickly sketching the outline of a large report or essay.

The program comes on a single floppy disk with 87K bytes of free space on it—a rarity in these days of bloated megaprograms. The slim, spiral-bound manual is clear and comprehensive.

You get two versions of the program: BRAIN.COM, the original command-line version, and POPUP.COM, the new TSR version; both versions are less than 30K bytes in code size.

In addition, you get UNLOAD.COM, a program that helps you remove resident Brainstorms from memory, and DIARY.COM, a utility that you can use to generate Brainstorm templates for a one-year diary with a choice of formats.

A Brainstorm outline (called a model) resides entirely in RAM. You can adjust

the size of the text buffer and how much memory it occupies by using another utility, called CUSTOM.EXE. This utility program also lets you define the screen colors on a color monitor and the hot key that pops up Brainstorm.

On my computer, I set up Brainstorm with a 60K-byte buffer so it occupied a total of 87K bytes. At this size, I could easily load two or more Brainstorms into memory simultaneously, with different color schemes and hot keys to distinguish them. The default hot key is Alt-Left-Shift, which didn't clash with any of my other TSR programs.

Brainstorm's overall scheme is very simple. It occupies your monitor's whole screen, presenting you with a framed, scrolling work area of 16 lines—the top line, which is a Title, plus 15 lines of normal text. The bottom of the screen gives you help and status information.

You can promote any of the 15 lines of normal text to be the title of a new screen of its own by pressing the Home key. Any line that has descendant screens is marked by an equal sign (=) in the left margin, whereas one without descendants displays a minus sign (-). Snow-free direct-video access on an IBM PC or compatible lets you flick up and down the hierarchy of screens

instantly with the Home and End keys.

The design scheme is different from those used in outliners like Symantec's ThinkTank, Ready!, and Grandview. These programs display the whole tree on one screen using indentations to mark the levels. They also expand and contract in concertina fashion as you reveal and hide levels.

Both approaches have their advantages and disadvantages. The Brainstorm approach works particularly well with, for example, a diary structure, where a month expands into days, hours, and so on. The other approach gives more of an overview of the structure, which is sometimes desirable.

Brainstorm can export an outline as an ASCII file, which you can view as an indented list in any word processor. It lets you print your outlines on any dot-matrix or laser printer with various degrees of indentation and line spacing.

One thing is certain—the Brainstorm approach is intuitive and easy to learn, and it uses very few commands. In the latest TSR version, you can perform most commands using IBM function keys, but the package also retains the older control-key commands for veteran users. Full-screen

editing facilities include automatic word wrap, although the margins are fixed.

Apart from moving around and entering text, the only commands you get are searching for a headline (you can use wild cards), pruning the tree structure, and jumping around the structure. You can mark a line anywhere in an outline using the @ sign and then jump to the mark from elsewhere. You can also move the marked line and all its descendants to the current position or vice versa (i.e., send the current line to the mark).

Namesaking is a unique feature of Brainstorm. When you enter identical headlines at different places in the structure, Brainstorm spots and automatically links them so you can jump from one to the other, hypertext-style. The new version lets you toggle Namesaking on and off to cover circumstances where it is not desirable.

The only part of Brainstorm that betrays its age is the file directory listing and loading section of the main menu, which still requires that you type filenames in full; the program cries out to be updated to a SideKick-style, point-and-shoot system using a cursor bar.

Brainstorm lacks many of the fancier features found in other outline processors like Grandview, such as sorting, categorizing, and advanced text formatting. However, its simplicity and speed fit its prime purpose well, which is to let you jot down thoughts as they occur and expand on them. In addition, its new status as a pop-up program makes it more attractive than ever in this role.

—Dick Pountain

THE FACTS

Brainstorm
£100

Requirements:

An IBM PC, 128K bytes of RAM, a floppy disk drive, and DOS 2.0 or higher.

Brainstorm Software Ltd.
18 Courtlands Close
Ruislip, Middlesex
HA4 8AX
U.K.
44-0895-677845
Inquiry 885.

WHAT'S NEW

INTERNATIONAL

A New Analysis Capability for @RISK

Version 1.5 of @RISK, the Lotus 1-2-3 add-in for risk analysis and simulation modeling (see What's New International, page 88IS-4, November 1988 BYTE), has a new analysis capability called Sensitivity Simulation. This feature lets you enter up to 25 different values for a variable using a new @function called @SIMTABLE, and then automatically runs a simulation for each value. @RISK's output routines process the data from all simulations and then present you with the results so you can compare the risk associated with each value that you chose for the variable.

@RISK 1.5 lets you configure the default presentation method for all graphics and customize graphics with labels prior to saving them in .PIC format. Enhanced zoom and overlay capabilities, as well as a new data filtering option, let you tailor the graphics appearance of results for better presentation and data interpretation.

The output module, @RISKGraph, has a new macro capability to make result manipulation and analysis more efficient through automation. Finally, version 1.5 helps you catch worksheet modeling mistakes by recognizing errors and letting you trace your mistakes in Lotus 1-2-3.

@RISK 1.5 requires an IBM PC with 512K bytes of memory, DOS 2.0, Lotus 1-2-3 version 2.0, and a graphics adapter.

Price: £325.

Contact: 4-5-6 World Ltd., Wellington House, Butt Rd., Colchester, Essex C03 3DA, U.K., 44-0206-579776.

Inquiry 955.

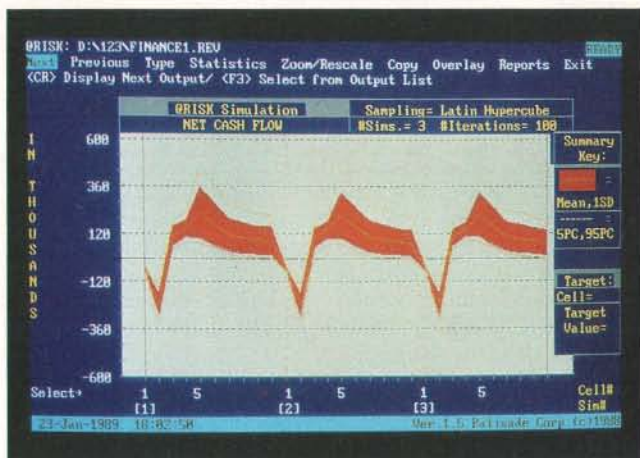

The Sensitivity Simulation in @RISK lets you enter up to 25 values for a variable and run a simulation for each value.

The First Micro Channel IV System

A VGA overlay card, the DVA-4000 is also a powerful digital video adapter that provides full manipulation of real-time video images: their size, position, brightness, saturation, contrast, and hue, as well as special effects such as fades and dissolves. In addition, DVA-4000's double-scan, noninterlaced output produces a sharp, high-resolution image with no text and graphics flicker, according to VideoLogic.

DVA-4000's overlay capability, using any standard VGA monitor, extends to all 17 VGA modes, with a graphics resolution as high as 640 by 480 pixels and 256 color choices from a palette of 256,000 shades.

When you run windowing applications, such as Microsoft Windows or Presentation

Manager, with the DVA-4000 card, you can display real-time or frozen video in one of the on-screen windows, scale a full screen of video to size, and position it anywhere on the screen. You can also confine video and graphics effects exclusively to the video window and display two live video sources in windows on the same screen in different sizes and locations.

You can import video from a variety of sources, including off-air TV, videodisk, videotape, CDI, DVI, and S-VHS, and add sound from sources such as the computer's built-in speaker or through headphones, stereo speakers, or a multisync monitor with audio.

The DVA-4000 requires a single slot in your IBM PS/2 Model 50, 60, 70, or 80. Included with the board is VideoLogic's Multimedia Interactive Control System software (see What's New International, page 96IS-18, April BYTE), which requires DOS

If you would like your new product considered for publication in the international section of BYTE, send press releases to BYTE, Attention: Martha Hicks, One Phoenix Mill Lane, Peterborough, NH 03458, U.S.A.; or Dick Pountain, BYTE, McGraw-Hill Publishing Co., 34 Dover St., London W1X 3RA, U.K.; or Shouzou Watanabe, Editor in Chief, Nikkei BYTE, 1-1, Kanda-Ogawamachi, Chiyoda-ku, Tokyo 101, Japan. All press releases must contain price information, address, and telephone number.

3.1 and 64K bytes of memory.

Price: £1950.

Contact: VideoLogic Ltd., Unit 8, Home Park Industrial Estate, Kings Langley, Hertfordshire WD4 8LZ, U.K., 44-09277-60511.

Inquiry 938.

Design Urdu/English Databases

You can design bilingual databases with the Urdu Interface System. The UIS is a software development toolbox that lets you create, edit, display, and process Urdu and English text data simultaneously on an IBM XT, AT, or compatible. The system also lets you handle Urdu characters as standard ASCII characters for use from within most high-level languages.

You can use the UIS in C, Pascal, FORTRAN, and BASIC. It supports the dBASE III Plus programming environment, so you can create bilingual database systems without extra programming effort. An optional screen and form design tool lets you define data-entry and data display screens and formats.

The UIS requires 640K bytes of RAM, a CGA or Hercules monochrome adapter, and two floppy disk drives or one floppy disk drive and a hard disk drive. You can print a hard copy on Epson and compatible printers. The system is compatible with Structured Query Language-based Oracle and Informix-C.

Price: \$1200 U.S.

Contact: Incorporated Technologies, 3-J, Gulberg-III, Lahore, Pakistan, 92-042-875000.

Inquiry 915.

continued

QUADGTi FROM INTERQUADRAM



**BRILLIANT
PERFORMANCE
BY A SUPER
INTELLIGENCE.**

VGA is the latest business graphics standard to emerge from IBM. QuadGTi is InterQuadram's latest display of intelligence — an intelligent VGA board that will now add the crisp resolution, superior colour selections and abundant palette range of VGA to your IBM or compatible computer.

It really is a highly intelligent, high-speed graphics adaptor.

How intelligent? Well, QuadGTi not only supports all 17 VGA modes with resolutions up to 800 by 600, but is upgradeable to a staggering 1024 by 768 resolution with the simple addition of 256k more memory.

It can sense whether you are running an 8 or 16 bit bus system, and automatically configures itself to run at maximum speed.

It senses both the monitor type and the RAM on board the card automatically, and with the use of the software drivers included the result will be you'll always get the highest resolution possible.

It supports all new IBM VGA graphic modes plus existing EGA, CGA, MCGA, MDA and Hercules, therefore QuadGTi is compatible with all of your existing and future software needs. Of course Register level and BIOS level compatibility are 100% guaranteed.

You can employ QuadGTi with your current digital monitor or take advantage of new multi-scanning or analog displays.

You'll find its price-performance ratio beats everything in sight. So our super-intelligent QuadGTi makes a very intelligent buy!

INTERQUADRAM
LIMITED



**GRAPHICS ADAPTORS AND MONITORS • MEMORY/MULTIFUNCTION BOARDS
PRINTERS AND BUFFERS • COMMUNICATIONS AND NETWORKING SOLUTIONS • IBM COMPATIBLE PORTABLE COMPUTERS**

InterQuadram Limited, 653/4 Ajax Avenue, Slough, Berkshire SL1 4BG, England. Tel: (0753) 36464. Telex: 847542 INTQAD G. Fax: (0753) 77256.
InterQuadram Computers GmbH (Germany), Hermannstr 52, D-6078 Neu-Isenburg, West Germany. Tel: (6102) 17 095. Telex: (041) 41 77 25. Fax: (6102) 17 090.
InterQuadram S.A.R.L. (France), 136 rue Perronet 92200 NEUILLY France. Tel: (1) 47 22 58 20. Telex: 615728 F INTQUAD. Fax: (1) 46 40 10 15.

The Ultimate Modem

Mayze Systems claims its multistandard Synchro 1496 is the ultimate modem—it gives you a wide range of transmission techniques that are suitable for everything from simple dial-up service access to sophisticated high-speed point-to-point operation, and it lets you transmit data at speeds ranging from 1200 bps to 14,400 bps.

The Synchro 1496 combines the benefits of a Hayes-compatible auto-dial V.32 9600-bps modem with the additional transmission techniques of V.33, V.29, V.25-bis, and V.22bis. It uses trellis coding and local- and remote-echo cancellation and provides 12 preset configurations that are suitable for most applications; you can also modify and store any of the configurations. A separate command port configures and monitors call progress without interrupting the main data channel.

When leased-line failure occurs or line quality drops, Synchro 1496 can load an alternative configuration, initiate a PSTN call, and automatically restore the link. As soon as normal operation is restored, Synchro 1496 can switch back to the leased line without manual intervention.

A remote-control facility lets you use the dial-up line interface to prepare configurations off-line. You can then download these configurations to remote modems without interrupting the main data channel. You can also use the remote-control facility to configure the remote modems where the configuration does not match the host.

The Synchro 1496 is available in stand-alone and rack-mount versions.



The Synchro 1496 gives you a wide range of transmission techniques and speeds.

Price: £1995 for the stand-alone version; £1945 for the rack-mount version.
Contact: Mayze Systems Ltd., Delta 900, Great Western Way, Swindon, Wiltshire SN5 7XQ, U.K., 44-0793-511789.

Inquiry 935.

Three-Dimensional Modeling on a Color Mac

Vision is a three-dimensional modeling application that gives you lathe and extruder creation tools, a library of standard building blocks, and a coordinate-entry system for precisely known, three-dimensional shapes.

The program's creation tools include manual coordinate entry, automatic polyhedra creation, more than 12 three-dimensional building blocks, and plan-elevation entry from Apple Desktop Bus digitizers. You can edit at the vertex, edge, facet, and object levels, as well as at line intersections. Vision also gives you rendering methods that let you color your models, draw them as wireframes, and shade them according to the setting of two light sources.

Using the keyboard, you can change camera attributes such as position, focal point, and zoom. You can also group a collection of camera positions into a flight path that you can play back, interpolating to provide smooth movement for video production. An internal help facility, which is indexed by topic, is provided.

Vision requires a Mac II, IIX, or IICX, 2 megabytes of RAM, and an 8-bit color graphics adapter. If you use Vision on a Mac Plus or SE, you also need a 68881 coprocessor card.

Price: \$120 New Zealand. Site licenses and a multiuser version are available on request.

Contact: Paul Bourke, P.O. Box 76425, Manukau City, New Zealand, 64-9-737-999.
Inquiry 958.

Three Monitors for the Mac II

All three miroGraph monitors from Miro Datensysteme are 20 inches wide with display areas of 360 by 270 mm, a bandwidth of 110 MHz, a screen refresh rate of 75 Hz, and a resolution of 1024 by 768 pixels.

The miroGraph Pencil 20P is a black-and-white monitor. The miroGraph Prisma GS

gives you 256 gray scales, and the miroGraph Prisma 20S is a color monitor that offers you 256 colors from a palette of 16 million shades. The Pencil 20P and the Prisma GS are Philips dark-glass tube monitors, while the Prisma 20S is a Sony Trinitron color monitor.

Each of the miroGraph monitors lets you choose between high and low resolution—you can switch from the workstation resolution of 1024 by 768 pixels to the standard Macintosh resolution of 512 by 384 pixels. You can use the monitors with the Mac II, SE, or Plus.

Price: \$995 U.S. for the Pencil 20P; \$1795 U.S. each for the Prisma GS and the Prisma 20S.

Contact: Miro Datensysteme GmbH, Gifhorner Strasse 28, D-3300 Braunschweig, West Germany, 49-05-31-32791.
Inquiry 954.

An Easier Way to Connect Cables

The Eton 23 connectors make it simple for you to mate two- or three-wire cables. Once you insert the wires into the connectors, you use ordinary pliers to depress the plunger atop its body, and the plunger strips the wires axially and crimps them. The connectors can handle wires from 0.4 to 0.9 mm, carry currents of up to 3 amps, and withstand power surges of up to 10,000 volt-amps.

Price: 490 French francs for 1000 connectors.

Contact: Electronic & Technology, 36 Rue Marcel-Dassault, 92100 Boulogne, France, 33-1-46091941.

Inquiry 922.

continued

Monitors from INTERQUADRAM

The complete range of displays



CAD/CAM Monitor ▲



VGA Analog Colour ▲



VGA Analog Mono Monitor ▲



Multi Scan Monitor ▶

◀ EGA Colour Monitor



InterQuadram, Europe's largest supplier of 3rd party monitors, now offer a comprehensive range of monitors.

All monitors are designed and manufactured to the highest specification to meet your needs and suit your budget.

All Quadram monitors have an integral tilt and swivel base, giving users the optimum individual viewing position.

EGA COLOUR MONITOR

14inch monitor, 0.31 mm dot pitch, supports EGA 640 x 350 resolutions.

MULTI-SCAN MONITOR

14inch TTL digital/analog VGA compatible monitor, auto picture sizing supports 800 x 600.

VGA ANALOG COLOUR MONITOR

14inch analog monitor, VGA compatible unlimited colour choice.

VGA ANALOG MONO MONITOR

14inch analog mono monitor, VGA compatible. Capable of displaying 256 grey scales. Flat screen for crisp clear images.

CAD/CAM MONITOR

Large 20inch monitor, supporting 1280 x 1024 resolutions. Ideal for CAD/CAM & DTP applications.

INTERQUADRAM

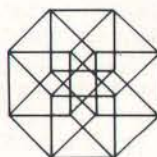

InterQuadram Limited, 653/654 Ajax Avenue, Slough, Berkshire SL1 4BG, England.

Tel: (44) 753 36464. Telex: 847542 INTQUAD G. Fax: (44) 753 77256

GRAPHICS ADAPTORS AND MONITORS ● MEMORY/MULTIFUNCTION BOARDS
PRINTERS AND BUFFERS ● COMMUNICATIONS AND NETWORKING SOLUTIONS ● IBM COMPATIBLE PORTABLE COMPUTERS

All trademarks fully recognised.

Communicate Better on Novell Networks

Artefact has released two programs that expand the communications facilities of Novell networks. Net-Monitor is a memory-resident program that lets you communicate with, view, and use other stations in a network, and Multimon is a non-memory-resident program that lets you observe and control several connections made by Net-Monitor at the same time.

Using Multimon, you can simultaneously view parts of up to eight screens in windows and follow the activities on all stations. Switching from station to station requires only one command, and zooming in on a window means that you can have a window take up the whole screen temporarily.

When these programs are integrated with Novell's security system, you can add special groups to protect users and extend or restrict their capabilities. By creating a chain, you can display the screen of one workstation on a selection of other stations.

Price: \$495 U.S. for Net-Monitor; \$995 U.S. for Multimon; \$545 U.S. for a separate upgrade from Net-Monitor to Multimon.

Contact: Artefact, Nassaulaan 2A, 2628 GH Delft, The Netherlands, 31-15-621246.

Inquiry 937.

Park Guardian Keeps Your Data Secure

If your data files are not .COM or .EXE programs but distributed data files that contain instructions for other programs, you probably know that you cannot use standard copy protection for that

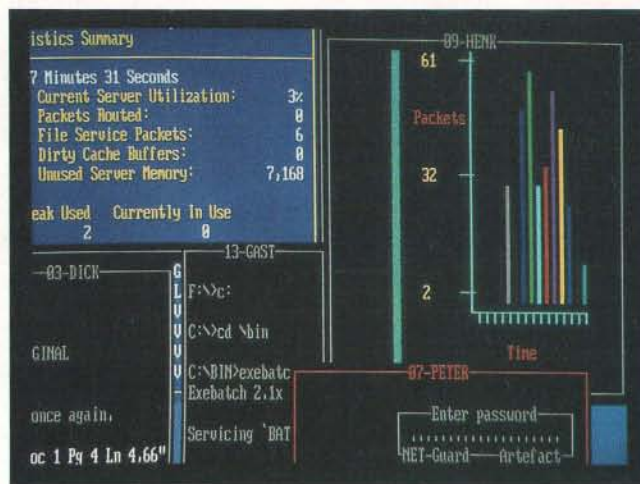

Multimon lets you follow the activities on all network stations.

data. In response to this problem, Park Guardian offers a new security product specifically for protecting distributed data files.

FileSafe protects your distributed data files by linking them to a specific program that works with them, so there is no way anyone can access and read the files using other programs or utilities. You can use FileSafe in conjunction with CodeSafe, and you can also limit it to a predetermined number of executions by using DemoSafe (see What's New International, page 96IS-34, January BYTE).

Two configurations are available. In the first configuration, the protection and encryption key is a copy-protected disk that you cannot copy. In the second configuration, the protection and encryption key is a plug that you connect to your computer's Centronics parallel port. In both configurations, the protection is completely transparent and is fully compatible with all computers, printers, and software, according to the company.

Park Guardian also offers TotalSafe, which gives you protection against unauthorized access to your IBM PC system running under DOS.

TotalSafe is a data-security software product that resides in a chip that you can easily install into your computer. It also identifies viruses in the operating system and prevents the execution of virus-infected programs.

The security features include boot protection, which gives you security against cold or warm boots from floppy disk drives by unauthorized persons. The product blanks your computer's screen to prevent unauthorized viewing of information while your computer executes a program, and it locks your keyboard when you are away from your computer. Another feature disables your computer's printing capabilities while it is unattended.

Additional security features disable the format command to the floppy or hard disk and disable the FDISK command. The hard disk write-protection function prevents anyone from writing to, erasing, or updating software or data that resides on your hard disk.

FileSafe and TotalSafe require an IBM PC with 128K bytes of RAM and DOS 2.0. **Price:** £300 for the FileSafe master disk; £15 for a 5 1/4-inch FileSafe signature disk; £17.50 for a 3 1/2-inch FileSafe signature disk; £145 to £195 for TotalSafe.

Contact: Park Guardian Ltd., 508-514 Market Towers, 1 Nine Elms Lane, London SW8 5NQ, U.K., 44-01-720-8715.

Inquiry 966.

ISO-Compatible Optomagnetic Disks

The OC112 series of double-sided 5 1/4-inch optomagnetic disk media from Hitachi Maxwell gives you a storage capacity of 644 megabytes. The disk's sector formatting is compatible with the final recommendation of the International Organization for Standardization, with 1K byte per sector, 17 sectors per track, and 18.751 tracks per disk.

Two types are available: a glass substrate version, called the OC112G, and a plastic version, called the OC112P. The disks ensure 107 and 106 rewrites, respectively. The OC112G is currently available, while the OC112P will be available in July.

Price: 45,000 yen for the OC112G; 30,000 yen for the OC112P.

Contact: Hitachi Maxell Ltd., 2-1-7 Nishi Honbashi-ho Honcho, Chuo-ku, Tokyo 103, Japan, 81-03-241-9736.

Inquiry 888.

Fix

Intelligent Environments Ltd., whose product Crystal was mentioned in the April What's New International, page 96IS-8, has a new address and telephone number. You can contact the company at Northumberland House, 15-19 Petersham Rd., Richmond, Surrey TW10 6TP, U.K., 44-01-940-6333. We apologize for any inconvenience caused by the use of the outdated contact information.

continued

IBM compatible boards from INTERQUADRAM

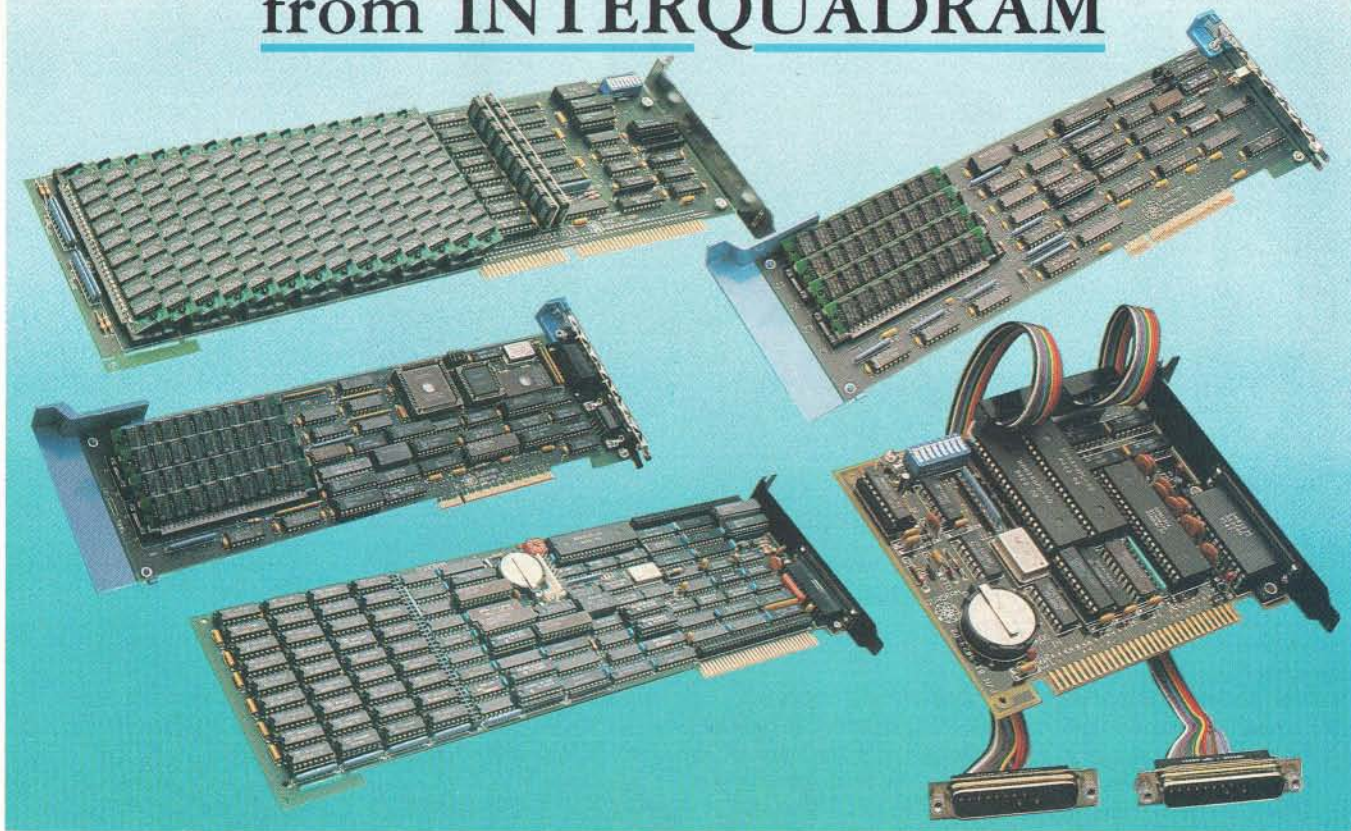

IBM PS/2 50/60/70/80

QuadMEG PS/Q: Memory board for IBM PS/2 50/60. Up to 4Mb of Expanded, LIM 4.0 & OS/2 Extended memory.

Quadboard PS/Q: Multi-function board for IBM PS/2 50/60. Up to 4Mb of Expanded, LIM 4.0 & OS/2 Extended memory, including 1 serial & 1 parallel port.

QuadMEG PS/8: Memory board for IBM PS/2 70/80. Up to 8Mb of true 32bit memory. Supports Expanded, LIM 4.0 & OS/2 Extended memory, 1 serial & 1 parallel upgrade option.

Quadboard PS/8: Multi-function board for IBM PS/2 70/80. Up to 8Mb of true 32

bit memory. Supports Expanded, LIM 4.0 & OS/2 Extended memory includes 1 serial & 1 parallel port.

Quad I/O: I/O ports for IBM PS/2 50/60/70/80. Quad I/O parallel features a bi-directional parallel port. Quad I/O serial includes 2 serial ports & 1 parallel port.

IBM PC/AT 286/386

Quadram AT: Up to 4Mb of Expanded, LIM 4.0 & OS/2 Extended memory. Compatible with CPU speeds up to 24 MHz.

QuadPort AT: 1 serial & 1 parallel port, with option of an additional 4 serial ports.

IBM PC/XT 8088/8086

Model 30 Quadboard: Up to 2Mb of EMS memory with 1 serial & 1 parallel port.

QuadPort XT: 1 serial & 1 parallel port, option of additional serial port.

IBM PC/XT/AT

Quad EGA: Autoswitching Graphics adaptor supporting EGA, CGA, MDA & Hercules.

Quad GTi: 100% register level VGA card supporting EGA, CGA, MDA & Hercules.

All trademarks fully recognised.

INTERQUADRAM

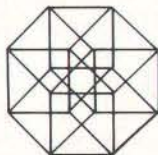

InterQuadram Limited, 653/654 Ajax Avenue, Slough, Berkshire SL1 4BG, England.
Tel: (44) 753 36464. Telex: 847542 INTQUAD G. Fax: (44) 753 77256

Germany: InterQuadram Computer GmbH. Tel: (49) 6102 17095

France: InterQuadram S.A.R.L. Tel: (33) 1 47225820

INTERQUADRAM have distributors all over Europe

AUSTRIA: Micropoint Warenvertriebs GmbH.
Telephone: 02236/82575

BELGIUM: Trüstr International. Tel: 02 660 8922
Sagitta B.V.B.A. Tel: 015 202322

CYPRUS: Mechatronic Ltd. Tel: 02 444192

DENMARK: Techware A/S. Tel: 02 94 81 19

FINLAND: Amic OY. Tel: 90 673200

GREECE: Atko Computer Systems SA. Tel: 01 7704802

HOLLAND: Akam Electronics bv. Tel: (0) 79 443200

ICELAND: Mikro hf. Tel: 91 685 610

Ortolvutaekni-Tolvukaup hf. Tel: 91 687 220

IRELAND: Sound Systems plc. Tel: 01 537841

Q Fax Ltd. Tel: 01 521142

ISRAEL: Mono-Mode Trading Ltd. Tel: 03 5711170-1

ITALY: Tradinform S.r.l. Tel: 06 451911

NORWAY: Dataimport AS. Tel: 05 314085

PORTUGAL: Decada Equipamentos de Electronica
& Cientificos S.A. Tel: 01 410 3420

SPAIN: SDI. Tel: 91 413 72 46

SWEDEN: Dataimport AB. Tel: 08 716 94 55

SWITZERLAND: Mini-Peripherals AG. Tel: 042 36 58 77

TURKEY: G.I.S. Ltd. Tel: 1 347 4858

YUGOSLAVIA: Boman Establishment (Liechtenstein).
Tel: 23945

Two Products for AutoCAD Release 10

Control Systems—Europe has written a version of its Artist GT software driver specifically for AutoCAD Release 10 that lets you use a separate display list for each viewport.

In addition to the right margin and pull-down menus in Release 10, Artist GT provides a movable, windowed, mouse-controlled icon menu, with 16 color switches and 26 touchpad keys that control more than 20 transparent commands. Six zoom options on the Artist GT icon menu include zoom all, zoom previous, zoom window, zoom up, zoom down, and zoom bird's-eye view.

A switchable screen display lets you transparently operate two to four concurrent screens, with each screen fully controllable as a separate viewing window. View load and view save commands let you load and save your drawings for easy presentation.

The Artist GT driver for AutoCAD Release 10 supports Control Systems' Artist XJ10, a 16- or 256-color graphics controller with a resolution of 1024 by 768 pixels noninterlaced. The Artist XJ10 features a modular design that uses plug-in modules to upgrade to 256-color and single-screen capabilities.

All Artist GT drivers require add-on EMS memory. **Price:** \$20 U.S.

Contact: Control Systems—Europe, Killé House, Chinor Rd., Thame, Oxon OX9 3NU, U.K., 44-084421-7445.

Inquiry 923.

Cambridge Computer Graphics (CCG) offers a new AutoCAD driver that lets users of AutoCAD Release

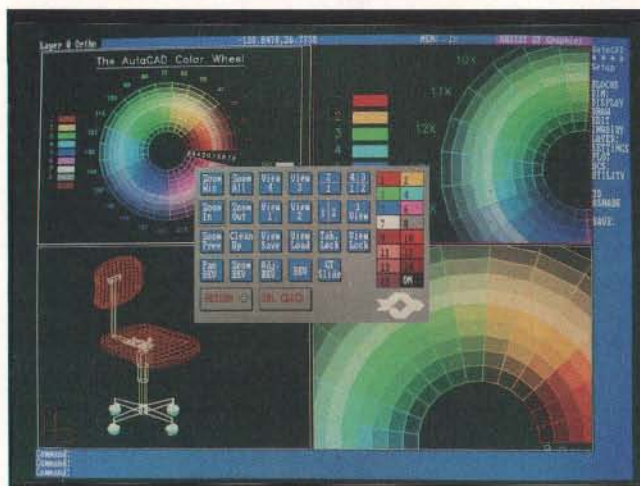

Control Systems' AutoCAD 10 driver lets you operate two to four concurrent screens.

10 take advantage of the graphics performance available from its Xcellerator range of display systems and graphics coprocessors (see What's New International, page 48J, April 1987 BYTE).

The Release 10 driver adds 20 improvements to the AutoCAD 10 user interface. It operates with Xcellerator 1024 or 1600, giving you 20-inch screen displays at a 1024- by 768-pixel resolution with 256 colors, or a 1600- by 1200-pixel resolution with 16 colors when you use it with CCG display hardware.

CADScope, a pop-up window, gives you a bird's-eye view of the whole drawing while letting you select a new drawing area for zoom or pan. The driver assigns an independent display list to each of Release 10's four window viewports. Fast zoom of up to 64 times is available for each window, with a maximum of 1024 times on a full drawing. For larger zooms, you use AutoCAD's own zoom.

Using a cameo window in the border that highlights the currently active viewport, you can quickly select and rapidly zoom and pan to any detail in any one of four views.

You use CCG's own com-

mands, which are transparent to AutoCAD, to handle slides. Unlike AutoCAD's VSLIDE and MSLIDE, CCGVSLD and CCGMSLD are zoomable. A fast drag feature uses a random redraw pattern to give you a more realistic outline of the dragged object, and a claw function lets you pan a drawing directly in step with the movement of the digitizer puck or pen.

The driver for AutoCAD Release 10 is included with any CCG screen.

Contact: Cambridge Computer Graphics Ltd., Graphics House, Convent Dr., Waterbeach, Cambridge CB5 9QT, U.K., 44-0223-863311.

Inquiry 924.

Add an External Floppy Disk Drive to Your IBM PC

Samways' external floppy disk drive adapter cable lets you add an external floppy disk drive to your IBM PC, XT, AT, or compatible so you can transfer data to and from laptop computers or connect a tape backup unit.

Two versions of the connector are available: a nonpowered version and a powered version in which the computer's internal power

supply powers the drive. You install the adapter cable inside the computer in place of the existing drive controller cable. The powered version comes with an internal cable and an external cable with a power connector.

Both versions of the external floppy disk drive adapter cable are available for drive controllers with a 34-pin header or with a 34-pin edge connector.

Price: \$42 U.S. for the nonpowered version; \$80 U.S. for the powered version.

Contact: Samways Electronic Engineering, P.O. Box 46, Robertson 2577, N.S.W., Australia, 61-48-851541.

Inquiry 959.

Ichitaro 4.0

Just Systems' Japanese-language word processing software, Ichitaro 4.0, is now available as standard equipment with Hanako 2.0 for Hitachi's PROSET30 personal work tools (see What's New International, page 96IS-38, May BYTE) and for NEC's PC-9801 series of computers.

The company plans to offer versions for IBM Japan's PS/55 S/Ts, Toshiba's J-3100s, Hitachi's B16s and AX machines, Fujitsu's FM-Rs, and Matsushita Electric's Panacom M series of computers. A high-resolution version will also be available for NEC's PC-98RL machine.

Price: 58,000 yen for each version.

Contact: Just Systems Corp., 3-46 Okihama-Higashi, Tokushima 770, Japan, 81-0886-54-1319.

Inquiry 887.

continued



The PC environment you want...

INDUSTRIAL AUTOMATION SYSTEMS

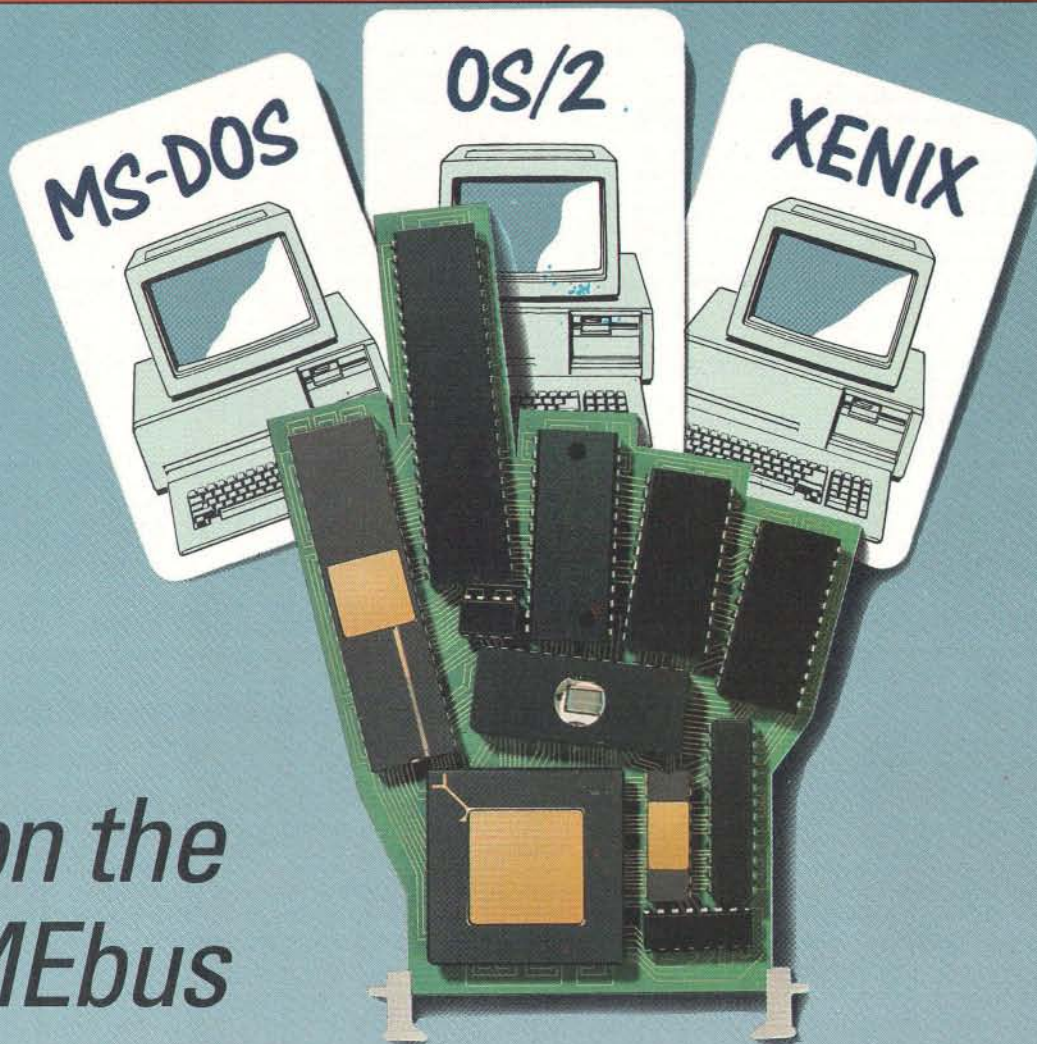

... on the VMEbus

Now, Philips gives you the PC environment you want on the VMEbus. With MS-DOS, for direct access to the world's largest application library. Plus the capability to support advanced operating systems like OS/2 and XENIX for your future software development projects and multi-tasking applications.

The result is an important enhancement of VMEbus hardware and software versatility with the full capabilities that these PC environments offer.

The Philips PX4010 PC/AT module has a 10 MHz 80286 CPU, and offers full AT-compatible PC functionality. With a stand-alone configuration that includes 1.64 MB system RAM, graphics adapter for CGA, EGA and Hercules standards, on-board controller for hard and floppy disks, keyboard interface, real-time clock, parallel port and 2 RS232/RS422 ports. Plus an XT bus that allows connection of any standard PC extension cards.

Like all Philips VMEbus hardware and software, the PX4010 module is backed-up by full technical support for integration with VMEbus real time operating systems, including the high-performance Philips ERM system.

So get the benefits of full PC functionality on the VMEbus. And get the choice of today's and tomorrow's PC environments.

The following trademarks and registered trademarks are acknowledged:
PC/AT, OS/2, CGA, EGA: IBM Corp.
MS-DOS, XENIX: Microsoft Corp.
Hercules: Hercules Computer Technology, Inc.

For more information:

AUSTRALIA
(2)8 86 82 22

AUSTRIA
(2 22)60 10 10

BELGIUM
(2)5 25 61 11

DENMARK
(6)81 65 22

FINLAND
(0)75 91 00

FRANCE
(1)49 42 80 00

F.R. GERMANY
(5)116786 (0)135

GREAT BRITAIN
(223)315558

HONG KONG
(5)28 32 98

INDIA
(22)4 92 15 00

IRELAND
(1)90 93 90

ITALY
(39)3 63 51

THE NETHERLANDS
(40)78 83 25

NEW ZEALAND
(9)89 41 80

NORWAY
(9)87 71 10

PORTUGAL
(1)68 31 21

SINGAPORE
3 60 20 00

SPAIN
(1)4 04 22 00

SWEDEN
(8)89 00 10
(8)89 00 20

SWITZERLAND
(1)4 88 22 11

U.S.A.
(20)15 29 38 00

For countries not listed
Philips Industrial Automation
Building HKF-49
P.O. Box 218
5600 MD Eindhoven
The Netherlands
31-40 784 321

Are you searching for those elusive Low cost PS/2 MEMORY expansion BOARDS ?

You have found them. They are OS/RAM4 and OS/RAM8.

* IBM Approved ID

* Automatic configuration ensures easy Installation. * Plus TWO Year WARRANTY†

* Supports all Operating systems include DOS, OS/2, Xenix, etc. * Supports both Extended and Expanded Memory (LIM 4.0). * Works In All MCA based machines like PS/2 model 50,60,70,80. As well as other manufactures MCA compatible machines like Olivite, Apricot, etc. * Proven, fully compatible with MCA.

OS/RAM4 supports up to 4MB of DRAMs on a single card. With OS/RAM8 you can add up to 8MB and two serial ports to your system on one board. Of course you can add more memory cards if you so wish

	Prices	Product Code
	+VAT	
4MB OS/RAM4 (0k) DRAM	£227.56	RAM40
4MB OS/RAM4 populated with 2MB DRAM	£760.01	RAM42
4MB OS/RAM4 populated with 4MB DRAM	£1307.47	RAM44
8MB OS/RAM8 (0k) DRAM+ two serial ports.....	£282.03	RAM80
8MB OS/RAM8 plus 2MB DRAM	£814.49	RAM82
8MB OS/RAM8 plus 4MB DRAM	£1361.94	RAM84
8MB OS/RAM8 plus 6MB DRAM	£1909.39	RAM86
8MB OS/RAM8 plus 8MB DRAM	£2456.85	RAM88
2MB Memory modules	£557.45	RAM02

**PLUS A 20-DAYS MONEY BACK GURANTEEE. Please add VAT to all the above prices
No surcharge for postage and packing within UK.**

**ADVANCE
MICROPROCESSOR
DEVELOPMENT
SYSTEMS Ltd**

7-11 Kensington high street
London W8 5NP

Tel : 01 937 4643

†DRAM's are not support by the warranty.

PS/2 and MCA are trademark of IBM. OS/RAM4 and OS/RAM8 are trademarks

of Captial Equipment Corp.

WHAT'S NEW

INTERNATIONAL

Prototyping with Intelligence

You can speed up the development of custom functions for the STEbus with British Telecom's IPB (intelligent prototyping board). Based around a 64180 processor, the board offers a free area for breadboarding new designs. It is ideal for the development of slave processor peripherals to a main CPU, a design approach that can multiply overall system throughput and extract phenomenal performance from an 8-bit-wide STEbus, according to the company.

Integrated with the 64180 processor are two bytewise memory sockets, an STEbus interface based around a FIFO buffer for asynchronous communications with the rest of the

computer system, and two RS-232C serial I/O ports. A patch area routes 48 of the core computer's control signals to the prototyping space for easy connection to your custom circuitry. The interface lets you mount a standard 48-way connector on the site and gives you adjacent space for a 24-pin programmable array logic to handle the control logic. The remainder of the board is patterned with plated-through holes on a 0.1-inch grid. Circuit traces along the board's edge are available for the distribution of 0, 5, and ±12V power.

Price: £250.

Contact: British Telecom Research Laboratories, Martlesham Heath, Ipswich IP5 7RE, U.K., 44-0473-642933.

Inquiry 920.

Make Friends with VERSAdos

Real-time multitasking operating systems can have an uncomfortable user/machine interface. In most cases, the way the user interface or the command-line interpreter is written, you have to reenter incorrect input commands in full because edit features are not available.

To help solve this problem, VMEsystems has developed a command-line editor that makes the user/machine interface of VERSAdos, Motorola's multitasking operating system for the 68000 family of microprocessors, more user-friendly. The company enhanced the session manager, which controls the dialogue between you and your system, so you can use functions such

as cursor left, cursor right, insert character, and delete character with the command-line editor. You can also recall command lines you have previously entered by using a circular buffer system with configurable depths; then, either with or without correction, you can reenter them to the system.

The command-line editor package runs with VERSAdos 4.51 or higher. It comes on a 5¼-inch floppy disk with help files in English and German. To install it, you exchange four files and, during the next system process, link them to the operating system.

Price: 250 deutsche marks.

Contact: VMEsystems GmbH, Butzbacherstrasse 16, D-6308 Butzbach 3, West Germany, 49-6033-6193.

Inquiry 916.

continued

USA SOFTWARE IN EUROPE!

NO COSTLY PHONE AND FREIGHT CHARGES!

QUICK DELIVERY! LOW PRICES!

Come pay us a visit at our new address.
Over 1,400 products available.
Call today for price list.

386 PRODUCTS:	Price
386\ASM/Link By Phar Lap Software	\$ 699
ADVANTAGE 386 C By Lifeboat	\$ 1079
ADVANTAGE 386 Pascal By Lifeboat	\$ 1079
FoxBASE+386 By Fox Software	\$ 565
Microsoft Windows/386 By Microsoft	\$ 231
NDP C-386 By MicroWay	\$ 805
NDP Fortran-386 By MicroWay	\$ 805
NDP Windows By MicroWay	\$ 173
OS/386 Software Developer's Kit By A. I. Architects	\$ 649
Paradox 386 By Borland	\$ 990
SCO XENIX System V Complete 386 By Santa Cruz Ops	\$ 1919
System V/386 Complete By Microport Systems	\$ 1191
VM/386 By IGC	\$ 299
X-AM/386 By IGC	\$ 719

ARTIFICIAL INTELLIGENCE:	
Arity/Prolog Compiler & Interpreter By Arity Corporation	\$ 785
muLISP-87 Development System By Soft Warehouse	\$ 549
PROLOG-2 Professional By Expert Systems	\$ 1079
Turbo Prolog By Borland	\$ 169
Turbo Prolog Toolbox By Borland	\$ 115

ASSEMBLER, LINKERS & TOOLS:	
ADVANTAGE Disassembler By Lifeboat	\$ 315
Microsoft Macro Assembler By Microsoft	\$ 473
Plink 86Plus By Phoenix Technologies	\$ 453
Series 3.0 8086/88 Macro Assembler By 2500 AD Software	\$ 145
Turbo Assembler and Debugger By Borland	\$ 181

BASIC LANGUAGE & TOOLS:	
Microsoft QuickBASIC By Microsoft	\$ 121
Stay-Res Plus By MicroHelp	\$ 151
True BASIC By True Basic	\$ 125
True BASIC Btrieve Interface By True BASIC Company	\$ 89
Turbo Basic By Borland	\$ 115
Turbo Basic Database Toolbox By Borland	\$ 115

C LANGUAGE:	
C-terp By Gimpel Software	\$ 305
Instant C By Rational Systems	\$ 698
Microsoft C Compiler By Microsoft	\$ 515
Microsoft Quick C Compiler By Microsoft	\$ 121
Turbo C 2.0 By Borland	\$ 170
Turbo C 2.0 Professional By Borland	\$ 297

C LIBRARIES & TOOLS:	
C ASYNCH MANAGER By Blaise Computing	\$ 215
C Library By POLYTRON	\$ 125
C TOOLS PLUS By Blaise Computing	\$ 159
C Utility Library By Essential Software	\$ 213
dbASE C Tools Programmer's Library By Ashton-Tate	\$ 101
Greenleaf Functions Library By Greenleaf Software	\$ 227
Multi-C By Cytek	\$ 199
Turbo C Tools By Blaise Computing	\$ 159

COMPUTER AIDED DESIGN:	
AutoCAD Release 10 By Autodesk	\$ 4205
AutoCAD Release 9 By Autodesk	\$ 3995
AutoSketch Enhanced By Autodesk	\$ 118
Design Cad By American Small Business	\$ 297
Generic 3-D By Generic Software	\$ 355
Generic Cadd By Generic Software	\$ 105

COBOL LANGUAGE & TOOLS:	
COBOL spII By Flexus	\$ 519
Level II COBOL By Micro Focus	\$ 459
Microsoft COBOL Compiler v3.0 By Microsoft	\$ 1049
Realia COBOL By Realia	\$ 1398
RM/COBOL Development System By Ryan-McFarland	\$ 1117
RM/Screens By Ryan-McFarland	\$ 519

COMMUNICATIONS:	
CARBON COPY PLUS By Meridian Technology	\$ 239
CrossTalk XVI By CrossTalk/DCA	\$ 179
Procomm Plus By Datastorm Technologies	\$ 85
Remote2 By CrossTalk/DCA	\$ 179
SmartTerm 220 By Persoft	\$ 217
VTERM/220 By Coefficient Systems	\$ 299

CROSS DEVELOPMENT:	
Lattice 68000 C Cross Compiler By Lattice	\$ 605
Lattice Z-80 Cross Compiler By Lattice	\$ 605
Quelo 68000 Cross Assembler/Linker By Quelo Company	\$ 779
Series 3.0 Cross Assembler By 2500 AD Software	\$ 285

DATABASE & FILE MANAGEMENT:	
Btrieve By Novell	\$ 299
Xtrieve By Novell	\$ 323
Xtrieve Report Option By Novell	\$ 193
XQL By Novell	\$ 959
c-tree with r-tree By FairCom	\$ 785
Clipper Summer '87 By Nantucket	\$ 747
d-tree By FairCom	\$ 599
dAnalyst By TranSec System	\$ 326

dB_FILE By Raima Corporation	\$ 479
dB_Retrieve By Raima Corporation	\$ 239
DBC III Plus By Lattice	\$ 845
dbFAST By dbFAST Inc.	\$ 115
DBXL Diamond By WordTech Systems	\$ 209
FoxBASE + By Fox Software	\$ 373
INFORMIX-4GL By Informix	\$ 1497
INFORMIX-ESQL By Informix	\$ 897
INFORMIX-SQL By Informix	\$ 1197
Magic PC By Aker	\$ 283
PARADOX 2.1 By Borland	\$ 763
QUICKSILVER Diamond By WordTech Systems	\$ 620
R&R Clipper/Foxbase+ Module By Concurrent Data Systems	\$ 65
R&R Relational Report Writer By Concurrent Data Systems	\$ 185
R:BASE FOR DOS By Micromim	\$ 803
Reflex: The Analyst By Borland	\$ 173

DEBUGGERS:	
Periscope I By PERISCOPE Company	\$ 839
Periscope III-10MHz By PERISCOPE Company	\$ 1679

DESKTOP PUBLISHING:	
PageMaker By Aldus	\$ 983
PagePerfect By IMSI	\$ 505
Ventura Desktop Publisher By XEROX	\$ 943

DISK, DOS, BACKUP & KEYBOARD:	
Back-It By Gazelle Systems	\$ 161
Copy II PC By Central Point Software	\$ 41
Copy II PC Deluxe Option Board By Central Point Software	\$ 493
Disk Optimizer By SoftLogic Solutions	\$ 75
FastBack Plus By Fifth Generation	\$ 175
MACE Utilities By Paul Mace Software	\$ 105
Norton Advanced Utilities By Peter Norton Computing	\$ 143
PC Tools Deluxe By Central Point Software	\$ 75
Q-DOS II By Gazelle Systems	\$ 93
Window DOS By Window DOS	\$ 57

EDITORS:	
EDT + By Boston Business Computing	\$ 400
Epsilon Text Editor By Lazarus Software	\$ 277
KEDIT By Mansfield Software	\$ 171
MKS VI By Mortice Kern Systems	\$ 109
SPF/PC By Command Technology	\$ 357
VEDIT PLUS By CompuView	\$ 191

FORTRAN LANGUAGE & TOOLS:	
ASMUTIL2 & BUTILE By Impulse Engineering	\$ 189
GRAFATIC & PLOTMATIC By Microcompables	\$ 943
Microsoft FORTRAN Compiler By Microsoft	\$ 527
No Limit Fortran Library By MEF Environmental	\$ 135
RM/Fortran Development System By Ryan-McFarland	\$ 739

GRAPHICS:	
ADVANTAGE Graphics By Lifeboat	\$ 255
Essential Graphics By Essential Software	\$ 285
GraphiC By Scientific Endeavors	\$ 479
GSS Graphic Dvpt. Toolkit By Graphic Solution Sys.	\$ 579
HALO '88 By Media Cybernetics	\$ 349
MetaWINDOW/PLUS By Metagraphics	\$ 339
STATGRAPHICS By STSC	\$ 837

LOCAL AREA NETWORKING:	
Advanced NetWare 286 with Keypad By Novell	\$ 3115
Btrieve/N By Novell	\$ 719
Dbase III Plus LAN Pack By Ashton-Tate	\$ 1095
FoxBASE+ Multi User By Fox Software	\$ 565
Networker Plus By WordTech Systems	\$ 271
Paradox For Network By Borland	\$ 1085
SFT NetWare 286 w/Keypad or DCB By Novell	\$ 5451

MACINTOSH PRODUCTS:	
Copy II Mac By Central Point Software	\$ 45
Eureka: The Solver By Borland	\$ 189
FastBack By Fifth Generation	\$ 95
FoxBASE+ By Fox Software	\$ 376
Freehand By Aldus	\$ 605
Guide 2 By Owl International	\$ 245
Microsoft BASIC Compiler By Microsoft	\$ 225
Microsoft FORTRAN Compiler By Microsoft	\$ 338
Pagemaker By Aldus	\$ 660
SideKick By Borland	\$ 119
Smalltalk/V By DigiTalk	\$ 285
Turbo Pascal By Borland	\$ 117
Turbo Pascal Database Toolbox By Borland	\$ 117

MODULA-2 LANGUAGE & TOOLS:	
Logitech Modula-2 Compiler By Logitech	\$ 123
Logitech Modula-2 Window Pack By Logitech	\$ 65
Repertoire/Btrieve Toolkit By PMI	\$ 155

OBJECT ORIENTED PROGRAMMING:	
Actor By Whitewater Group	\$ 599

Smalltalk/V By DigiTalk	\$ 143
Smalltalk/V 286 By DigiTalk	\$ 285
Zortech C++ Compiler By Zortech	\$ 155

OPERATING SYSTEMS & TOOLS:	
Concurrent DOS 386 3 Users By Digital Research	\$ 409
Double DOS By SoftLogic Solutions	\$ 75
Microport DOS Merge 286 By Microport Systems	\$ 333
PC-MOS/386 1 User By Software Link	\$ 278
QNX Development System for 1 User By Quantum	\$ 851
SCO VP/ix for XENIX 386 By Santa Cruz Operations	\$ 999
SCO XENIX System V Complete 286 By Santa Cruz Op.	\$ 1559
System V/AT Complete By Microport Systems	\$ 861
Theos 286 By Theos	\$ 838
Wendin-DOS By Wendin	\$ 125

OTHER LANGUAGES, TOOLS & MISCELLANEOUS:	
APL*PLUS PC By STSC	\$ 657
Boeing Graph By Boeing Computer Services	\$ 359
Framework III By Ashton-Tate	\$ 799
Guide 2 for PC By Owl International	\$ 335
Hayes SmartModem 2400 Halfcard Inter. By Hayes	\$ 752
LapLink Plus By Traveling Software	\$ 149
LMI FORTH-83 Metacompile By Laboratory Microsys.	\$ 905
Lotus Agenda By Lotus	\$ 485
Microsoft OS/2 Programmer's Toolkit By Microsoft	\$ 411
Norton Guides By Peter Norton Computing	\$ 101
Ntivirus By Orion	\$ 41
PC/FORTH By Laboratory Microsystems	\$ 185
PolyMake By Polytron	\$ 185
PVCs Personal By Polytron	\$ 185
QEMM Expanded Memory Mgr./386 By Quarterdeck	\$ 65
RPG II Compiler By Lattice	\$ 1055
SideKick Plus By Borland	\$ 237
SMK Seidl Make Utility By Seidl Computer Engineer	\$ 135
SSP/PC Scientific Subroutine Library By Lattice	\$ 389
TimeSlice By Lifeboat	\$ 305
Tornado By Micro Logic	\$ 95
Vaccinate-Anti-Viral Program By Sophco	\$ 45
WordPerfect-English By WordPerfect Corp.	\$ 437
WordPerfect-French By WordPerfect Corp.	\$ 501

PASCAL LANGUAGE:	
Microsoft Pascal Compiler By Microsoft	\$ 353
Professional Pascal By METAWARE	\$ 293
Turbo Pascal Professional By Borland	\$ 299
Turbo Pascal 5.0 By Borland	\$ 180

PASCAL LIBRARIES AND TOOLS:	
Overlay Manager By TurboPower Software	\$ 59
Pascal TOOLS By Blaise Computing	\$ 173
Pascal Tools Programmer's Library By Ashton-Tate	\$ 109
T-Debug Plus By TurboPower Software	\$ 59
Turbo Pascal Database Toolbox By Borland	\$ 115
Turbo Pascal Developer's Toolbox By Borland	\$ 453
Turbo POWER TOOLS PLUS By Blaise Computing	\$ 161
TurboWINDOW/Pascal By Metagraphics	\$ 121

SCREEN DESIGN AND WINDOWING:	
DESQview By Quarterdeck	\$ 135
Greenleaf DataWindows w/Source By Greenleaf Software	\$ 305
Microsoft Windows By Microsoft	\$ 121
Microsoft Windows Development Kit By Microsoft	\$ 585
PANEL Plus By Lifeboat	\$ 505
POWER SCREEN By Blaise Computing	\$ 160
Vitamin C By Creative Programming	\$ 275
vLIB By Pathfinder Associates	\$ 135
Windows for Data By Vermont Creative	\$ 359

TRANSLATORS:	
BAS_C Commercial By GoToLess Conversion	\$ 305
BAS_C Economy By GoToLess Conversion	\$ 164
BAS_PAS Commercial By GoToLess Conversion	\$ 229
BAS_PAS Economy By GoToLess Conversion	\$ 124
dbX dbASE to C Translator By Desktop AI	\$ 775
FOR_C By Cobalt Blue	\$ 905
Metamorphosis By JH Shannon	\$ 509

UNIX/XENIX PRODUCTS:	
Microsoft COBOL Compiler - XENIX/286 By Microsoft	\$ 1159
PANEL PLUS By Lifeboat	\$ 817
Professional Pascal for Unix 386 By LPI	\$ 837
SCO FoxBASE+ for XENIX 286 By Santa Cruz Oper.	\$ 959
SCO MultiView for XENIX 286 By Santa Cruz Oper.	\$ 479
Terminal Control for XENIX By MainStream Systems	\$ 1199
Windows for Data for XENIX 286 By Vermont Creative	\$ 1117

USA SOFTWARE
 LIMMATQUAI 116 • 8001 ZURICH, SWITZERLAND
 PHONE: (01) 252-6710 FAX: (01) 2527795 TELEX: 814460
 (Attr: USA SOFTWARE)

Terms: EURO-CHEQUE, AMERICAN EXPRESS, VISA, MASTERCARD, EUROCARD, C.O.D.
 30 day billing for qualified companies in Switzerland.
 Special discounts for large or corporate buyers. All prices in US dollars.
 Add shipping charge from Zurich at prevailing rates.
 Prices subject to change without notice.
 Hours: 8:30 AM - 5:30 PM.

How to find the latest U.S.A. software and hardware products.

Introducing Scandec Tributor (USA) Inc.
Your new purchasing arm in the U.S.A.

We're bringing the latest, most innovative, microcomputer peripherals and software to international users, direct from the leading manufacturers.

STI offers complete factory warranties, technical support and competitive prices.

Current products include: Optical Character Recognition software and peripherals. 8" disk conversion systems. 9-track tape back-up systems. Hard-disk diagnostic software. Advanced DOS alternative. Communications Software includes Encryption. More products are being evaluated.

Tell us your needs and STI will provide the most cost-effective solution. Write or call: Scandec Tributor (USA) Inc., 3001 Redhill Ave., #1-217, Costa Mesa, CA 92626 U.S.A. Phone: 714-557-6781. FAX: 714-557-2219.

Dealer/distributor opportunities available.

STI

Scandec Tributor (USA) Inc.

Notice: International Micro Solutions, our first choice, has been used by a dealer in the U.K.

Two IBM PS/55s for Factory Use

Two of IBM Japan's PS/55 models are designed for use in factories. The 5502-TFA and the 5502-TFB feature five Micro Channel slots (rather than the conventional three); 20-MHz 80386 CPUs; 2 megabytes of main memory, expandable to 16 megabytes; and one 3½-inch floppy disk drive. The 5502-TFA also comes with an internal 60-megabyte hard disk drive, and the 5502-TFB comes with an internal 120-megabyte hard disk drive.

Price: 1.26 million yen for the 5502-TFA; 1.61 million yen for the 5502-TFB.

Contact: IBM Japan Ltd., 3-2-12 Roppongi, Minato-ku, Tokyo 106, Japan, 81-03-586-1111.

Inquiry 890.

HiSoft BASIC for Amiga Users

Now Commodore Amiga users can exploit the power of their machine without having to learn another computer language, thanks to HiSoft BASIC.

A high-specification compiler, HiSoft BASIC takes BASIC programs and converts them into super-fast machine code at the press of a key. Not only does it compile AmigaBASIC interpreter programs, but it also extends the language to include many of the features from QuickBASIC for the IBM PC and HiSoft BASIC for the Atari ST (see the March 1987 What's New International, page 48F). Additional language features include full recursive subprograms and functions, parameters passed by value or reference, and flexible looping constructs.

HiSoft BASIC supports all

Amiga library routines and also lets you link your compiled code with assembly language or C functions. An integrated editor gives you memory-to-memory compilations and interactive error correction. Your programs can be as large as your computer's memory allows; strings can be up to 16 megabytes in length, and arrays can be any number of dimensions and size.

Price: £99.95.

Contact: HiSoft, The Old School, Greenfield, Bedford MK45 5DE, U.K., 44-0525-718181.

Inquiry 914.

A V80 with a Jump-Prediction Mechanism

NEC's 25-MHz version of the V80 (μ PD70832) 32-bit microprocessor integrates 930,000 elements and is a successor to the V60/V70 microprocessors.

The V80 has a seven-level pipeline; 1K-byte cache memories for instructions and data; a jump-prediction mechanism, which holds the jump address for your last-executed jump-instruction-destination address; the ability to execute basic instructions without microcode; and a dedicated FPU bus.

NEC plans to add 33- and 45-MHz clock versions of the V80. The 33-MHz chip will offer 16.5 MIPS or a Gibson Mix value of 9.9 MIPS.

Price: 120,000 yen for the 25-MHz version; 150,000 yen for the 33-MHz version.

Contact: Nippon Electric Co. Ltd., 5-33-1 Shiba, Minato-ku, Tokyo 108, Japan 81-03-233-8147.

Inquiry 886.

continued

MCA SYSTEM



INPUT / OUTPUT ANALOG / DIGITAL

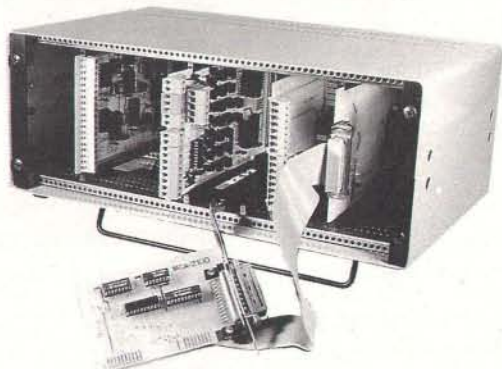

— 3 types of management:

- Basic programmable microprocessor 8052 board with RAM and EPROM
- Microcomputer (IBM, EPSON, CANON,...) over a parallel link interfaced by a mother board
- Computer-controlled RS 232 C interface

— Important line of I/O boards: More than 20 types

- From 8 to 64 channels
- TTL, Open-collector, Relays up to 120 VA
- Preloadable or dephased pulse counters
- Analog inputs and outputs, 8 and 12 bits resolution
- Motor driver boards: Stepper, DC
- Key board with 2 lines display
- Switch mode or battery power supplies
- Prototype board

— Up to 10 board, in a 3 U format rack

- Easy installation in backplane board with plug-in slots
- External connections through plug-in screw connector
- Simple programming in high level language such as Basic or Pascal

— Applications:

- Process control
- Data acquisition
- Dedicated apparatus
- Communication

KAP

35, rue des Meuniers
75012 PARIS-FRANCE
Tel: 33(1)46.28.51.28
Fax: 33(1)43.40.49.59
Telex: 210 023

FREE CATALOG ON REQUEST



NAME: _____
COMPANY: _____
ADDRESS: _____

A Preprocessor for Finite-Element Analysis

PREFEM is a finite-elements preprocessor that runs in an interactive graphics environment.

The program gives you pull-down menus and short response times. In addition, it lets you use CAD elements and Bézier splines, shrink or expand operations and projections on arbitrary planes, and define boundary conditions. You get automatic mesh generation, graphics-based control functions for all input data, a built-in management system for model data, a hidden-line module, text-processing capabilities, and an interface to FEM processor TPS10.

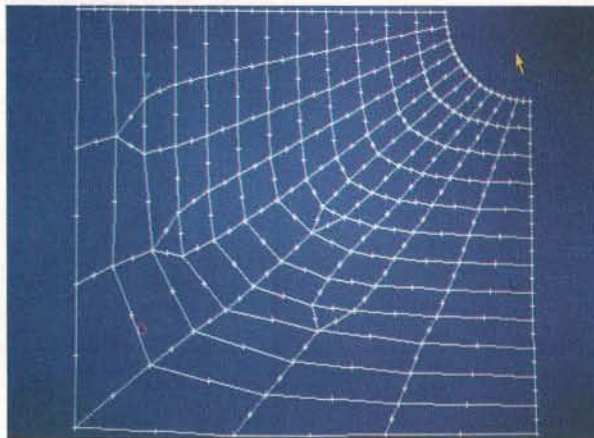

With PREFEM, you get graphics-based control functions for all input data.

PREFEM requires an IBM AT with 640K bytes of memory, DOS 3.2, an FPU, an EGA, and a Microsoft-compatible mouse.
Price: \$3700 U.S.
Contact: Maschinenbau

Entwicklung Consulting (MEC) GmbH, Dürerer Strasse 243, Postfach 1535, D-5180 Eschweiler, West Germany, 49-02403-23091.
Inquiry 929.

continued

The Computer Virus Crisis

If you wish you were more informed about computer viruses and the risks involved, then S&S Enterprises' new book *The Computer Virus Crisis* is for you.

The book includes information that can help you become better informed on the subject and shows you some precautions that you can take to reduce your risk of exposure to computer viruses.

Price: £13.95.

Contact: S&S Enterprises Ltd., Weylands Court, Water Meadow, Germain St., Chesham, Buckinghamshire HP5 1LP, U.K., 44-0494-791900.

Inquiry 948.

MAKE THE RIGHT CHOICE

In Software Protection

- Since 1983, over 280 000 keys sold to 1 400 Softwares houses and large corporations.
- High level protection due to the original combination of a physically unique hardware wiring for each software developer and encrypted assembler call routines (not an exposed driver).
- Lasting availability in over 55 langues under DOS, XENIX and OS/2.
- High potential but simple to install protection (no lengthy manual).
- Immediate technical support in every country with a Microphar distributor.
- Transparence on the parallel port assured by our experience in electronic configurations.
- Range of 7 key colours.



- 1) The **electronic key** is a device designed for identically reproduced software packages.
- 2) The **memory key** is a device in which registers can be addressed in groups or one by one :
 - * 62 bytes accessible for writing and reading
 - * 62 bytes used for error control in writing operations.

Reading and writing functions are also operationnal at the end-user level (without programing adaptor).

Useful for demo control, software leasing, sophisticated protection, date memorisation and any operation requiring a counter.

Please contact us to obtain our distributors' addresses :

BELGIUM, CANADA, EIRE, GERMANY, ITALY, NETHERLANDS, PORTUGAL, SPAIN, SWITZERLAND, U.S.A.



MICROPHAR

42 av. Sainte Foy - 92200 Neuilly-sur-Seine - FRANCE - Tél. (33) 1 47 38 21 21 - Fax. : (33) 1 46 24 76 91

WHEN THE CHOICE
IS TERMINALS
OR PCs,
PERICOM
HAS A UNIQUE
PERSPECTIVE.

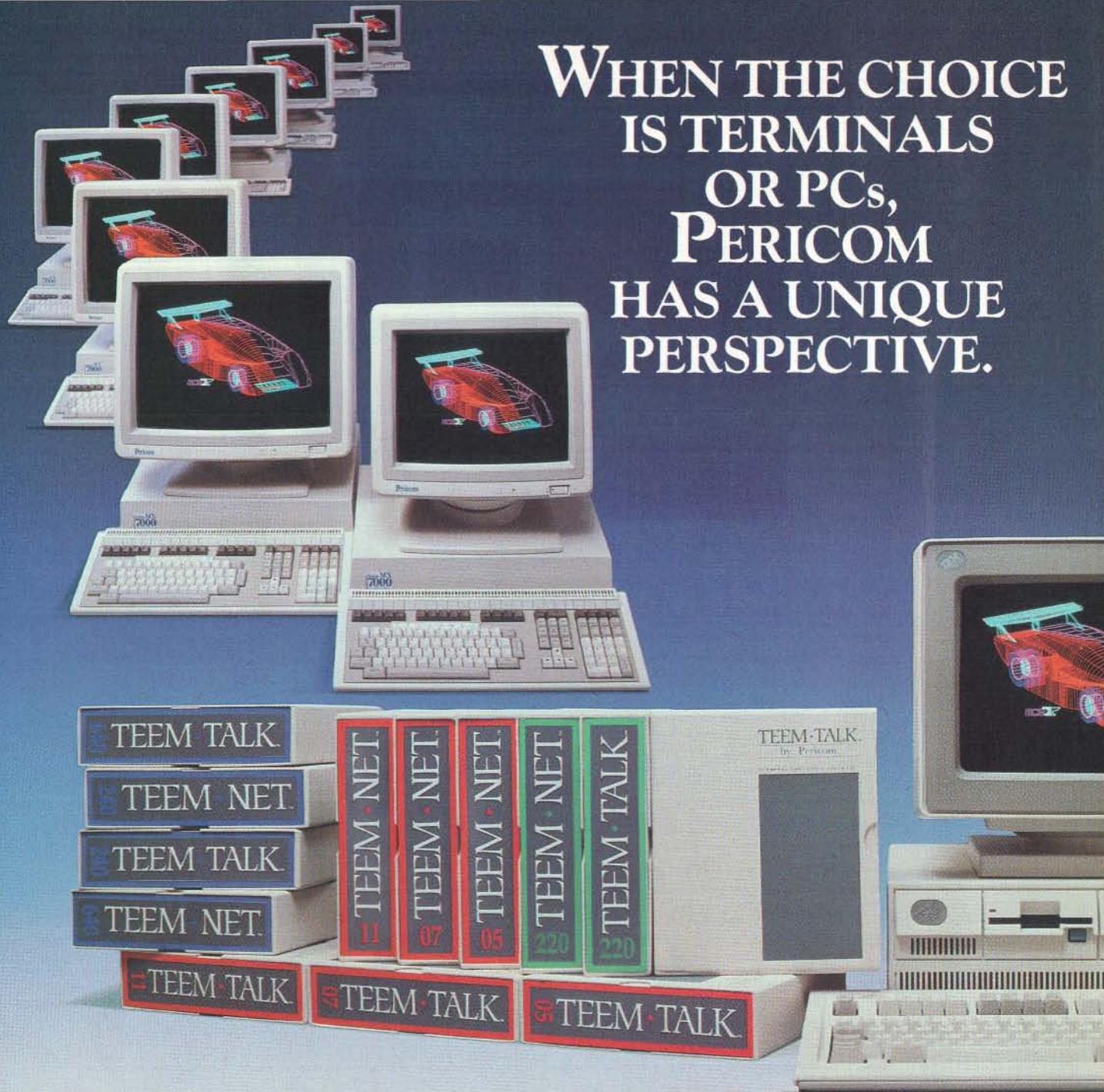

TWO SOLUTIONS, ONE COMPANY.

At Pericom our perspective is different. Unique in fact, because we manufacture a complete range of alphanumeric and graphic terminals *and* produce an innovative range of emulation software called TEEM-TALK and TEEM-NET.

Our hardware and software products provide compatibility with industry standard protocols such as DEC VT220, ReGIS, TEK 4205, 4207 and 4111. Specialist protocols including DG200 and VT640 are also available together with support for an extensive range of I/O devices.

The world's leading mainframe application software, from Data Processing to Computer Aided Design, will be at your fingertips as a

Pericom user, whatever your choice.

To help you make your decision we've prepared an informative new booklet called "*Terminals or PCs - the right choice*".

Get your free copy today by calling direct on: -

0908 568129

After all, it makes a lot of sense to buy terminal emulation software from a company that knows something about emulating terminals. Or vice versa.

 **PERICOM**
PRODUCT DIVISION

Video Capture for the IBM PS/2s

The IBM PS/2 version of the MicroEye IC full-color Video Capture Card takes full advantage of the Micro Channel architecture bus to provide a faster data transfer rate than the IBM AT-bus version (see What's New International, page 88A-3, March 1988 BYTE, and page 88IS-32, October 1988 BYTE). It also lets you display images you have captured in MCGA, VGA, and EGA standard.

The card can accept a full-color programmable-array-logic video picture and convert it into a bit map of 640 by 480 pixels and 16 million colors. Once you have captured



The MicroEye IC card incorporates on-board intelligence to simplify image capture on your IBM PS/2.

a picture, you can select the size and position you want to display it in on the PS/2's screen and save the images in PCX, GEM, TIFF, or bit-mapped format using a mouse-driven utility package.

The MicroEye IC card incorporates on-board intelligence to simplify image capture and uses two direct-memory-access channels to transfer image data from the card to the computer's mem-

ory. You can use software to configure it for color or monochrome operation, and it has programmable controls for brightness, contrast, and color saturation.

Price: £795.

Contact: Digithurst Ltd., 7 Church Lane, Royston, Hertfordshire SG8 9LG, U.K., 44-0763-42955.

Inquiry 936.

PCB Design Without the Frills

If you are looking for a low-cost printed-circuit-board design package that provides a comprehensive range of layout features without the expensive frills, then Number One Systems

continued

U.S. Battery-Powered Portable Workstation to Rival Compaq, Toshiba, and NEC with Slots, Speed, and Upgradeability

U.S. Micro Engineering (USME), a U.S. Designer and Manufacturer of Portable Computers, announced two new battery-powered Portable Workstations that offer Corporate America what they've been asking for . . . a lightweight portable with more Industry Standard Slots, High Contrast/Resolution Display, and an Upgradeable Processor!

The new EXECuMATE Portable workstations offer Five Internal Full-Length (16-bit) Industry Standard Bus slots that allow the end-user to plug in any IBM XT/AT Compatible Expansion Boards (Modem, Graphics, FAX, Mouse, Audio-Visual, etc.). You may install up to Eight Megabytes of zero-wait-state system memory without using one of the valuable Expansion Slots.

Both the EXECuMATE 286-20mhz and the EXECuMATE 386-25mhz come standard with a

VGA Double Super-Twist LCD Display offering a 20:1 contrast ratio (like the COMPAQ SLT/286). If your application involves many demonstrations, then look into the Optional Gas Plasma Display offering a 160° viewing angle with a 22 to 1 Contrast Ratio (nearly double the new Toshiba 5200).

These Portables offer the customer a choice of an Internal 3.5" PS/2 Floppy Disk Drive or a 5.25" AT Floppy Disk Drive.

The USME 102-Key Enhanced Keyboard offers a tactile feedback, full-sized keys with full-travel and spacing. It is equipped with a large return-key, twelve function keys, a separate numeric keypad, and cursor keys.

The standard 50mb Hard Disk offers 19ms Average Access Time (35% faster than the SLT, PROSPEED, and 5200). An onboard 64k Disk Cache can further reduce the effective seek time to 12ms.



Optional Internal Drives Include; a 125mb/200mb Hard Disk (10ms), a 40mb PLUS REMOVABLE Hard Disk, a 44mb BERNOULLI Drive, or a 650 mb OPTICAL Disk Drive.

USME can be reached at (303) 939-8700 or FAX (303) 939-8791.

Products on display at the N.Y. PC Expo Show June 20-22. Available through Holland Distributor.

Softline

INTERNATIONAL
DIVISION

Special Volume Discounts
Latest U.S. Versions
at U.S. Prices

1333 60th Street
Brooklyn, N.Y. 11219
Fax: 718-438-2315

Telex: 627-30170 or 910-240-3918

WE'VE MADE THE WORLD OUR BUSINESS.

Software

Word Processing/Editors

Ami'	\$ 99
Brief	169
Lotus Manuscript	339
Microsoft Word	229
Multimate Advantage II	269
PFS:Professional Write	119
Q&A Write	129
SPF/PC	159
Sprint	129
Volkswriter 3	159
WordPerfect	229
Wordstar Pro	249
Wordstar 2000+	259
Xywrite III Plus	219

Desktop Publishing

Arts & Letters Pres Pak II	189
A & L Graphics Composer	239
A & L Graphics Editor	429
Byline	199
Formfiler	99
Formtool	69
Formworx w/Fill'n File	99
Gem/3 DTP	189
Pagemaker	499
Per:form	159
PFS:First Publisher	79
Publish-It!	129
Publisher's Type Foundry	249
Ventura Publisher	469

Database & Tools

Btrieve	195
Btrieve Report Option	115
Btrieve/N	459
Btrieve/N Report Option	259
c-Tree	319
Clarion personal	99
Clarion professional	489
Clipper	449
d-Tree	399
DBase IV	479
DBase IV Devel.Edition	799
DBXL	129
Foxbase Plus	189
Foxbase Plus 386	309
Foxbase + Xenix	639
Genifer III	219
Informix 4GL	895
Informix SQL	719
Paradox 3	509
PC Focus	979
PFS:Professional File	179
Q&A	209
Q&A 386	229
Quicksilver	359
r-Tree	239
R:Base for DOS	469
R:Base compiler	629
Rapidfile	199
Revelation	499
UI Programmer	189
Windows for Data	295
XDB-SQL	459
XQL	619
Xtrieve	195
Xtrieve /N	459

Statistics

CSS with graphics	369
SPSS/PC+	675
Statgraphics	569
Systat w/Sygraph	679

Spreadsheets

Allways	\$ 89
Boeing Calc	209
Lotus 123	309
Lotus Agenda	269
Lotus Hal	99
Lucid 3-D	79
Microsoft Excel	259
Multiplan	135
Quattro	149
Supercalc 5	329
VP Planner Plus	129

Communications

Carbon Copy +	119
Crosstalk MK4	125
Crosstalk XVI	99
Mirror II	59
PC Anywhere III	75
Procomm Plus	59
Relay Gold	169
Remote 2	109
Smartcom III	149

Integrated Packages

Enable	399
Framework III	449
Lotus Symphony	459
Microsoft Works	109
Smart System	449

Desktop Environments

Desqview	89
Desqview 386	115
MS Windows 286	69
MS Windows 386	129
Sidekick Plus	129

Graphics

Autosketch enhanced	75
Designer	449
Draw Plus	259
Gem/3 Artline	289
Gem/3 Draw +	179
Gem/3 Graph	179
Gem/3 Presentation	289
Generic CADD	139
Graph Plus	319
In-a-Vision	289
Harvard Graphics	279
Lotus Freelance Plus	329
Master Graphics	259
MS Chart	269
Org +	69
PC Paintbrush Plus	79

Project Management

Adv.Proj.Mgr. Wkbench	819
Dan Bricklin Demo II	119
Flowcharting II +	159
Interactive Easyflow	125
Harvard Total P.M.II	429
Mathcad	219
Microsoft Project	329
Superproject Plus	259
Timeline	389
Timeline Graphics	119

Languages & Programming Tools

Lattice C compiler	\$229
Microfocus Cobol level II	1699
MS Basic compiler	199
Microsoft C	299
MS Fortran	299
MS Macro assembler	109
MS Quick Basic/Quick C	69
Norton Editor	49
Norton Guides	69
RM/Cobol	639
RM/Fortran	429
Source Print	89
Tree Diagrammer	69
Turbo Assembler	99
Turbo Basic	65
Turbo C/Turbo Pascal	99
Turbo C/ Pascal Prof	169
Turbo Prolog	99

Utilities

Copy II PC	34
Copywrite	72
Fastback Plus	105
Gofer!	59
H-Test/H-Format	55
Laplank Plus	99
Lotus Magellan	\$call
Mace Utilities	65
Norton Commander	59
Norton Utilities	65
Norton Util. Advanced	79
PC Tools Deluxe	59
Vaccine (anti-virus)	99
XTree Pro	79

Multuser/Network

Microport Unix V	569
MS Basic Xenix	249
MS Fortran Xenix	499
MS Pascal Xenix	499
Novell Adv.Network Lvl I	450
Novell Adv.Network Lvl II	979
Novell SFT Netware 286	3159
PC-MOS 5 user	469
PC-MOS 25 user	799
RM/Fortran Xenix	499
SCO Xenix Dev.Sys.	
286/386	479/649
SCO Xenix Oper.Sys.	
286/386	439/559
Smalltalk V/286	175
Tops for Dos	119

Hardware

Laptops

Toshiba T1600	3869
Toshiba T3100e	3269
Toshiba T3200	4199
Toshiba T5100	5499
Toshiba T5200	7375

Multifunction Boards

AST 6 Pak Plus (64k)	\$129
AST Advantage 286 (512k)	375
AST I/O Mini II - AT	79
AST Rampage + 286 (512k)	519
AST Rampage +/MC (512k)	519
Intel AboveBoard + (512k)	439
Intel AboveBoard + I/O (512k)	499
Intel Inboard 386AT	1129
Intel Inboard 386PC	775

Display Boards

AST VGA Plus	349
Autoswitch EGA 480	219
EGA Wonder 800	259
VGA Wonder 512k	469
Herc Graphics Card +	179
Paradise VGA Plus	289

Emulation Boards

AST 5251-11+	575
Irma II PCA/MCA	725

Modems

Evercom 24 Internal	135
Hayes 1200/1200B	299
Hayes 2400/2400B	449
Pract Periph 1200 Ext	129
Pract Periph 1200 Int	79
US Robotics 2400B	159

Networking

Arcnet Active hub	429
Arcnet Passive hub	79
Arcnet PC120 board	159
WDC Ethercard + (AT)	249

Printers/Plotters

Diconix 150	339
HP 7440 Colorpro plotter	1075
HP 7475A plotter(6 pen)	1475
HP 7550 plotter(8 pen)	3099
HP Deskjet	750
HP Laserjet II	1695
HP Laserjet II D	3349
IQ Supercartridge 1E	499
Pac Data 1MB for LaserjetII	359
Pac Data 25-in-1 cart.	309

Mass Storage/Backup

Mountain 40MB Int.Tape	389
Plus Hardcard 20	525
Plus Hardcard 40	669
Seagate ST225 w/int.(XT)	289
Seagate ST238 w/int.(XT)	319
Seagate ST251-1 (AT)	469
Seagate ST251 (AT)	409
Seagate ST4096 (AT)	699
Irwin 40MB Int. w/kit	409
Irwin 80MB Int. tape w/kit	509
Irwin 40MB Ext. w/int.(AT)	539
Irwin 80MB Ext. w/int.(AT)	649

Input Devices

Complete Hand Scanner	169
HP Scanjet w/ int.	1550
Keytronics KB101 keybrd	99
Logitech HI-Rez bus mouse	99
Logitech C-7 serial mouse	89
Logitech M-8 mouse w/ Paintshow	79
Logitech ScanMan	199
Microsoft mouse w/Windows	109
MS mouse w/PC Paintbrush	149
PC Mouse w/Paint	99

✓ **LOW PRICES**

✓ **SHIPPING EXPERTISE**

✓ **VOLUME DISCOUNTS**

✓ **KNOWLEDGEABLE STAFF**

To Place your order by telephone, please call **Fay Chayne • Intl. Sales Mgr.**

1-718-438-6057



TERMS: ALL RETURNS REQUIRE PRIOR AUTHORIZATION. 20% RESTOCKING FEE ON RETURNS. ALL PRICES SUBJECT TO CHANGE. CALL FOR CURRENT PRICES. PAYMENTS MAY BE MADE BY BANK CHECK, WIRE TRANSFER, L/C, MASTER OR VISA CARD (3% HANDLING FEE ON CREDIT CARD ORDERS). GOODS ARE SHIPPED VIA AIR MAIL (RECOMMENDED FOR SMALL ORDERS) OR AIR FREIGHT. ADD FREIGHT COSTS TO PREPAYMENT OR GOODS ARE SHIPPED FREIGHT COLLECT.

claims that its Easy PC is for you.

You can design multilayer circuit boards with up to eight layers, plus upper and lower silkscreens, with automatic extraction of drilling template and solder-resist artwork. Board designs can be up to

432 by 432 mm, with up to 12,000 track segments in 5000 tracks, 1500 symbols of up to 100 types per board, 4000 pads in addition to those in symbols, and 6000 text characters.

Easy PC gives you a choice of layout features, such as eight

active track widths from 0.002 to 0.531 inch, 16 active pad sizes, and 12 basic pad shapes, including circular, oval, rectangular, or finger, with or without holes. An optional auto-via facility gives you connections between layers. You can locate pads and tracks off-grid to a resolution of 0.002 inch and have a 0.1-inch basic grid with snap to 0.1-, 0.05-, or 0.025-inch steps.

Block and feature manipulation includes repeat, shirt, mirror, rotate, and erase. You can fix track angles at 45 degrees or let them run at any angle and move the cursor using the keyboard or a mouse; cursor readout can be in millimeters or inches.

You can add text annotations for copper or silk-screen layers and for schematics in

four character sizes with eight line thicknesses. You can also reverse the text or edit it after placement.

Easy PC requires an IBM PC with 512K bytes of memory, DOS 2.0, and CGA. Also available is a version for hobbyists, called Tiny PC, which has half the capacity and requires only 256K bytes of memory.

You can print out your designs on a standard dot-matrix printer with camera-ready artwork at one-quarter, one-half, one, two, or four times magnification.

Price: £275; £95 for Tiny PC.

Contact: Number One Systems Ltd., St. Ives, Huntingdon, Cambridge PE17 4WR, U.K., 44-0480-61778.

Inquiry 968.

continued

Turbo Prolog User's Handbook

The *Turbo Prolog User's Handbook* by Andrew Bradbury and Rory Woodward takes you through the basics of Prolog programming using the Turbo Prolog system. The handbook is written by experienced programmers in academic and business fields and is full of examples and advice. It is designed to provide a thor-

ough guide to Borland International's Turbo Prolog and includes the major changes in version 2.0.

Price: £17.95.

Contact: McGraw-Hill Book Co. (U.K.) Ltd., Shoppenhangers Rd., Maidenhead, Berkshire SL6 2QL, U.K., 44-0628-23431.

Inquiry 947.

Micromint now makes affordable Video Digitizing even better with ImageWise/PC™

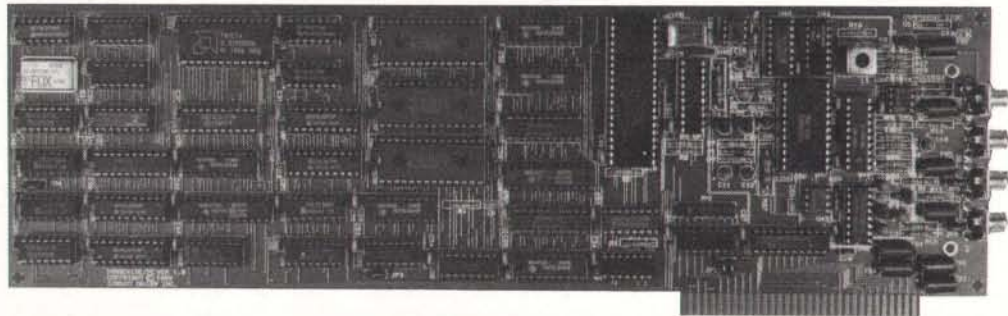

The company that made video digitizing affordable now makes affordable digitizing even better with ImageWise/PC. Bring your reports, graphics, security system, or video application up to the new standard in cost-effective gray scale video digitizing with the new ImageWise/PC.

- Digitize any NTSC, PAL, or SECAM video source!
- Up to 256x255 resolution with 256-level gray scale!
- True frame grabber—digitizes in 1/60 second!
- Digitizes 30 frames per second!
- Composite video output!
- Can display digitized pictures on EGA or VGA!
- Advanced overlay and split-screen capabilities!
- Digitized images compatible with paint and desktop publishing programs!
- Modify, enhance, display, and print images using sophisticated ZIP Software included with every ImageWise/PC!

ImageWise/PC
an affordable
£545

Price subject to "Exchange rates"

To order call:
J.B. DESIGNS & TECHNOLOGIES LTD.
15 Market Place
Cirencester, Glos. GL7 2PB
England
TEL: 0285-658122
FAX: 0285-658859



MICROMINT, INC. - 4 Park St., Vernon, CT 06066

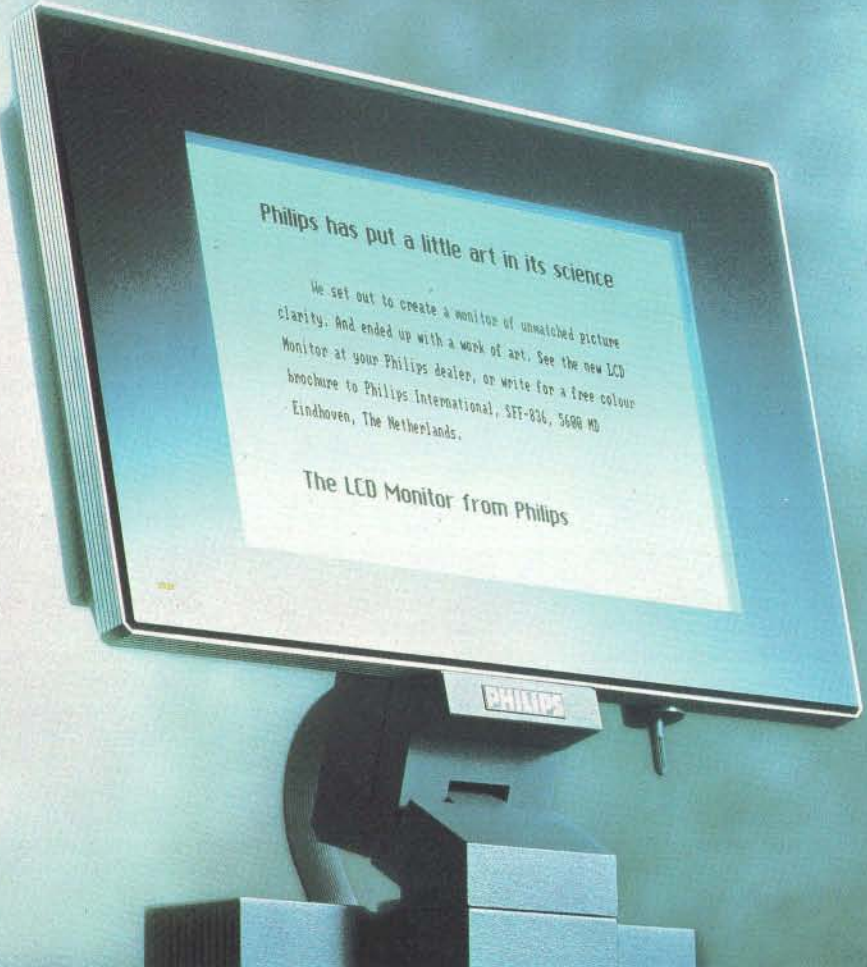

Philips has put a little art in its science

We set out to create a monitor of unmatched picture clarity. And ended up with a work of art. See the new LCD Monitor at your Philips dealer, or write for a free colour brochure to Philips International, SFF-836, 5600 MD Eindhoven, The Netherlands.

The LCD Monitor from Philips

**PHILIPS HAS PUT A LITTLE
ART IN ITS SCIENCE.**

We set out to create a computer monitor of unmatched picture clarity. ▶ The result is a work of art. ▶ Our new LCD Monitor is flat and small, to fit any workplace. ▶ It's lightweight, for easy positioning. ▶ The picture itself is stable and is exceptionally easy to read and sharp to the edges, with black letters on a white background. ▶ The radiation level of this LCD Monitor is virtually zero—far below the most demanding health regulations and ergonomic standards. ▶ For the complete picture of our full range of Computer Monitors, write Philips International, SFF-836, 5600 MD Eindhoven, The Netherlands. ◀
THE LCD MONITOR FROM PHILIPS



Circle 437 on Reader Service Card

PHILIPS

JUNE 1989 • BYTE 96IS-21

Software for Data Processing and Control

You can slash the development time for industrial data processing and computerized control applications by a factor of six with the Processyn application generator, according to Logique Industrie. The software handles routine programming and debugging steps and provides seamless connectivity to most industrial peripherals. In addition, the company claims that the program's user interface has a familiar vocabulary that minimizes operator training requirements.

By adding the appropriate modules, Processyn can simultaneously interface with most



Processyn gives you seamless connectivity to most industrial peripherals.

peripherals or combinations of peripherals, including programmable logic controllers, loop controllers, analog and digital data-acquisition systems, shop-floor terminals, management computers, and

LANs. The modular structure also lets you expand it by adding new peripheral descriptors, processor functions, or data structures.

Written in Microsoft Pascal, Processyn lets you inte-

grate other routines written in that language and can also provide data to outside spreadsheet and integrated programs, such as Symphony, Lotus 1-2-3, or Multiplan. The program is available in English, French, and German; Spanish and Italian versions are currently under development.

Processyn requires an IBM XT with 512K bytes of RAM, DOS 3.1, and a hard disk drive. Possible applications include process management and control; alarm supervision and monitoring; automated production management; data acquisition and centralization; scientific, technical and economic simulation; and centralized technical data management.

Price: 15,000 to 80,000

continued

HAVE QUESTIONS ABOUT COMPUTER PRODUCTS FOR BLIND PEOPLE?

The American Foundation for the Blind's (AFB) National Technology Center maintains an information system to provide data on consumer products ranging from canes, braille watches and games to sophisticated computers, training centers, demonstration facilities and evaluations of devices.

The system also includes AFB's Job Index/User Network which features information from over 1,100 blind and visually impaired people who use adaptive equipment in a variety of jobs. These individuals are willing to share their experiences and provide valuable advice to assist you in your educational and employment pursuits.

For information in print, large print or braille, contact:

**National Technology Center
American Foundation for the Blind
15 West 16th Street
New York, NY 10011
(212) 620-2080**

D-Link[®]
Local Area Network

The Smart Solution To Your Multi-User Needs

Industry Standard

D-Link hardware and software products are designed to meet the industry-standard. This guarantees you against obsolescence, and ensures a long-lasting return on your investment.

Our high performance Ethernet Interface Card can network any combination of PC/XT/AT and PS/2 Micro Channel™, to share valuable resources across the network. Furthermore, it has the ability to support TCP/IP, NETBIOS, Novell's NetWare™, IBM PC LAN Program and Sun Microsystems' PC-NFS™ software.

Our LANsmart Network Operating System is NETBIOS compatible and supports DOS 3.1 file/record locking standard. Hence, you can run all third party multi-user application software available on the market.

Ease of Use

D-Link LAN products are extremely easy to install and operate. Using pop-up windows, all options are listed on the screen for your ready selection to guide you through each operation.

Affordability

D-Link is designed for cost conscious users and carries a very reasonable price tag. Following the industry standard, D-Link is compatible with all major LAN products which ensures that your LAN will never become obsolete.

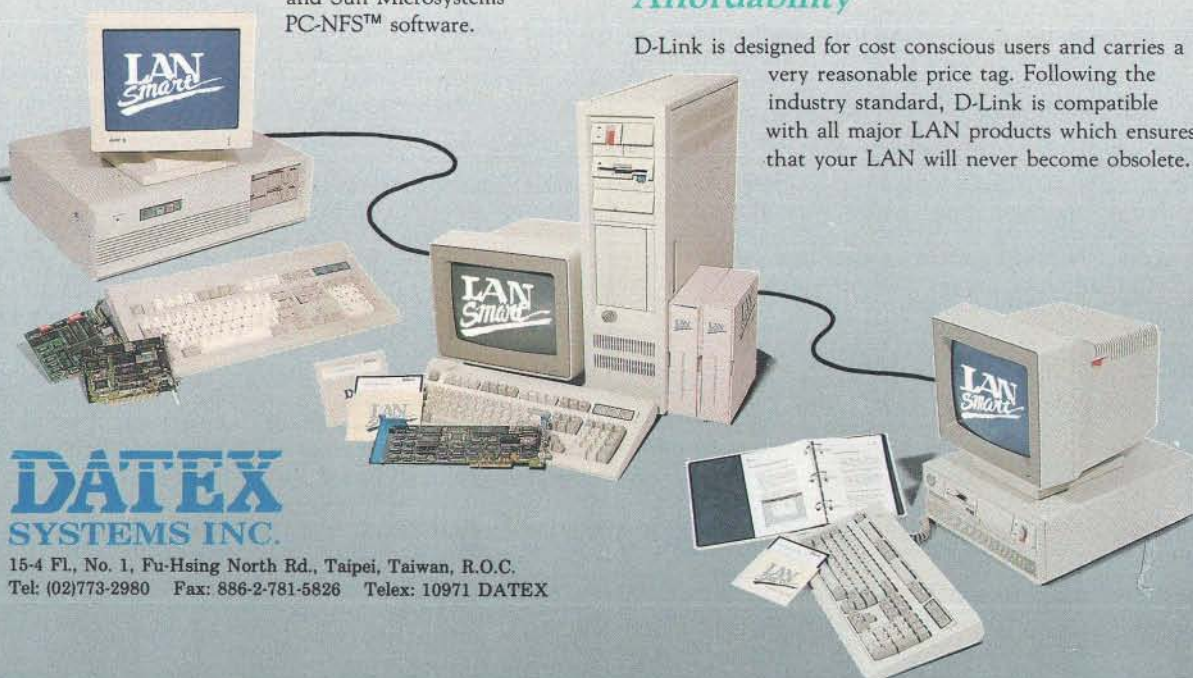

DATEX
SYSTEMS INC.

15-4 FL, No. 1, Fu-Hsing North Rd., Taipei, Taiwan, R.O.C.
Tel: (02)773-2980 Fax: 886-2-781-5826 Telex: 10971 DATEX

IBM PC/XT/AT, PS/2, Micro Channel are registered trademarks of International Business Machine Corporation.
NetWare is a registered trademark of Novell Inc.

Ethernet is a registered trademark of Xerox Corporation.
LANsmart and D-Link are registered trademarks of Dutex Systems Inc./Localnet Communications Inc.

Circle 408 on Reader Service Card

JUNE 1989 • BYTE 96IS-23

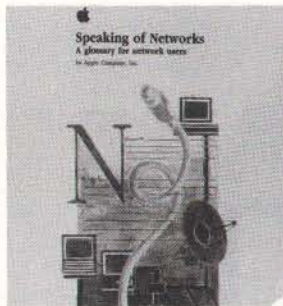

**Speaking of Networks:
A Glossary for Network Users**
Apple Computer, Inc.
Each term in this alphabetically arranged glossary is defined on two or three levels: a level for technical novices who need basic user-friendly definitions; one for those readers already acquainted with networking concepts; and an advanced level for technical sophisticates.
ISBN 0 201 51761 2/250pp/Paper/1989

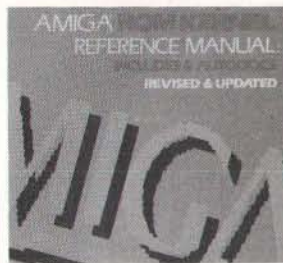

Amiga Rom Kernel Reference Manual: Includes & Autodocs Revised & Updated
Commodore-Amiga, Inc.
This book contains Amiga C and Assembly Language include files, function Autodocs, and IFF documents. It provides essential programming materials.
ISBN 0 201 18177 0/768pp/Paper/1989

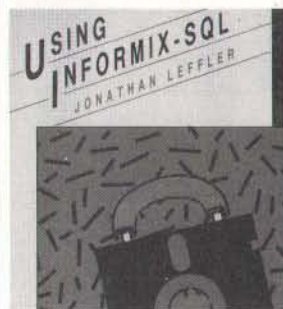

Using Informix SQL
Jonathan Leffler
An introduction to Informix SQL aimed at end-users, and a reference work for programmers. Informix SQL is a complete relational database management system based on the standard SQL, the best-selling database for Unix machines, and also available for MS-DOS, PC-DOS and VMS.
ISBN 0 201 51240 8/300pp/Paper/1989



Getting Started with Xerox Ventura Publisher 2.0
Wichert van Engelen
ISBN 0 201 51573 3/200pp/Paper/1989

Mathematica: A System for Doing Mathematics by Computer
Stephen Wolfram
ISBN 0 201 19330 2/350pp/Paper/1988

For further information on our publications, please complete the coupon below and return it to:

ADDISON-WESLEY, De Lairesestraat 90,
1071 PJ Amsterdam, The Netherlands

YES ADDISON-WESLEY!

Please send me more information on your publications.



Name _____

Address _____

Postal Code _____

Country _____

Telephone _____

BY1

French francs for the industrial package. Run-time and teaching packages are also available.

Contact: Logique Industrie, Le Mercure A, Z.I. d'Aix-en-Provence, 13763 Les Milles Cedex, France, 33-42-24-34-45.

Inquiry 956.

A Numerical Library for Lisp

Although Lisp is now an established standard in symbolic programming, it suffers from a lack of numerical software libraries compatible with its powerful symbolic capabilities. The Lissys numerical library for the Mac is intended to fill that need.

The Lissys numerical library consists of mathematical routines that were written entirely in Common Lisp and are fully portable. It offers high-level functions frequently required in scientific, mathematical, or engineering problems and lets you perform numerical analysis totally within Lisp.

The libraries cover the following areas: interpolation; curve and surface fitting; spline fits and surfaces; least-squares fits for arbitrary user-defined functions; roots and minima of equations; multivariate optimization, including constraint functions; and solution of simultaneous linear and nonlinear equations.

A graphics interface is provided so you can plot graphs of arbitrary functions, fitted data, and color-contour plots. In addition, you get an interactive menu-driven application that offers almost the full power and flexibility of the Lissys library in a transparent environment.

The scratch window is an editor window in which you type data and equations; it lets you cut and paste and save

operations. The application also puts up a Lisp listener window.

The Lissys numerical library is currently available as compiled code for Allegro CommonLisp on the Macintosh and Lucid Common Lisp on Sun machines; Lissys can also accommodate other Common Lisps, according to the company. The package comes with sample sessions demonstrating the use of all the library functions, demonstration files for the graphics interface, and the full source code for the graphics interface.

Price: \$950 U.S.

Contact: Lissys Ltd., 5 Winterburn Way, Loughborough LE11 0EW, U.K., 44-509-235620.

Inquiry 930.

An 80386-Based Industrial Computer

The ABC i3 industrial computer from Multitechnic features an 80386 microprocessor and a clock speed that is switchable between 16 and 25 MHz, running with zero wait states. The computer comes with 2 megabytes of RAM, expandable to 8 megabytes, eight free slots, a 1.44-megabyte 3 1/2-inch floppy disk drive, an 80-megabyte hard disk drive (access time 28 ms), a Hercules-compatible monochrome card, and a 14-inch monitor.

A standard 19-inch box installs in an industrial rack. You can also upgrade it to a fully waterproof and dustproof unit using optional special locker equipment.

Price: 26,000 Dutch florins for a standard unit.

Contact: Multitechnic B.V., Postbus 226, 3720 AE Bilthoven, The Netherlands, 31-030-287855.

Inquiry 926.

continued



The Design System That More Than Fits The Bill!

Looking for a CAD system? Then at only £499, PCDOGS+ from PAFEC will more than fit the bill. As a powerful upgrade to our highly successful PCDOGS package PCDOGS+ offers a host of new facilities including:

- **USER FRIENDLY INTERFACE**
Featuring pop-up menus, rubber banding, continuous co-ordinate readout.
- **FULLY CONFIGURABLE**
Parametrics, symbols facilities and the option of user definable menus allow you to tailor PCDOGS+ to your exact requirements.
- **POWERFUL DESIGN FACILITIES**
40 views, support of large drawings, properties and drawing office management makes PCDOGS+ the ideal choice.

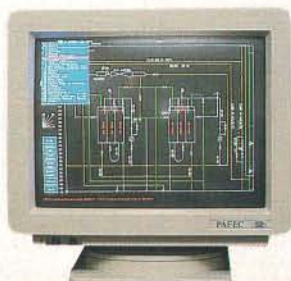

- **COMPREHENSIVE SUPPORT**
On-line help and tutorials, plus PAFEC's worldwide renowned support and training ensures you receive the best backup available.

PCDOGS+ runs on IBM - PC's and compatibles, and support a wide range of peripherals including printers, plotters and digitisers.

So, if you are thinking about CAD you couldn't make a better choice than PCDOGS+ ...

... and the Bill, that's just £499!

Write or phone for our brochure and you'll see why we are Europe's largest independent engineering software house.

For further information please contact Leanne Wright.

PAFEC LIMITED · STRELLEY HALL · NOTTINGHAM NG8 6PE · ENGLAND · 0602 292291 (Int. +44 602 292291).

Circle 434 on Reader Service Card

JUNE 1989 • BYTE 96IS-25

THE HIGHEST PERFORMANCE BOARD IN THE 386 WORLD

A STATE-OF-THE ART DESIGN FROM AMERICAN MEGATRENDS INC. U.S.A.

KAOTEC 80386-20 SYSTEM



KT-8000 386 MINITOWER CASE
KT-8001 386 DESKTOP

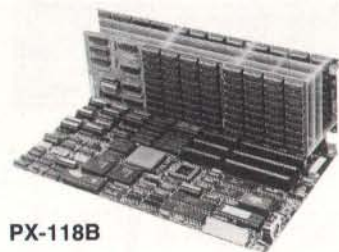

PX-118B



TR-6001 DESKTOP
TR-6002 SLIMCASE

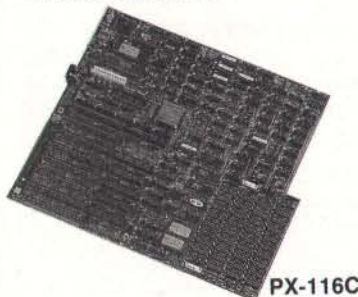

PX-116C

See us at:



COMPUTEX
TAIPEI '89
June 6-12, 1989
STAND A4006



HWA HSIN ELECTRONIC CO., LTD.

5F., NO. 12, LANE 538, CHUNG-CHENG RD.,
HSINTIEN, TAIWAN, R.O.C. TEL: 886-2-9153375
FAX: 886-2-9186892 TELEX: 35210 TRONIX

SPECIFICATIONS

- 64KB CACHE MEMORY
- INTEL 32 BIT 80386-20/25MHz CPU
- 128K ROM (AMI BIOS + EGA BIOS)
- SOCKET FOR 80387 CO-PROCESSOR
- 20/25MHz SYSTEM CLOCK
- SYSTEM CLOCK SWITCH BY KEYBOARD (AMICLK FOR EUROPEAN KEYBOARD PROGRAM)
- 8 LAYERS P.C.B.
- 6 EXPANSION SLOTS: 1 x 32, 4 x 16, 1 x 8
- OPTION 2MB/8MB RAM BOARD CAN BE EXPANDED TO 10MB/16MB BY INSTALLING 8MB PIGGY BACK
- AMI BIOS-386 BUILT-IN-SET-UP & DIAGNOSTICS
- PERFORMANCE NORTON SI23.0 LAMARK TEST 30MHz /40MHz
- 32 BIT ROM BIOS FASTER THAN SHADOW RAM
- DALLAS SEMICONDUCTOR REAL TIME CLOCK DS-1287A; WITH AN INTERNAL ENERGY SOURCE POWER DURABLE OVER 10 YEARS (MAINTAINS AN ACCURACY OF 1 MINUTE PER MONTH AT 25°C)
- EMS DRIVER AVAILABLE BY SOFTWARE OF AMI SEEMS
- AMD 80286-10/80286-12 MICRO-PROCESSOR
- 6MHZ, 8MHZ, 10MHZ or 12MHZ SYSTEM CLOCK WITH LED INDICATOR
- SOFTKEY SELECTABLE SYSTEM CLOCK
- HARDWARE RESET JUMPER
- 512K/640K/1024K/2048K/4096K BYTES RANDOM-ACCESS MEMORY (RAM)
- DALLAS SEMICONDUCTOR REALTIME CLOCK DS-1287A WITH AN INTERNAL ENERGY SOURCE POWER DURABLE OVER 10 YEARS (MAINTAINS AN ACCURACY OF ± 1 MINUTE PER MONTH AT 25°C)

An On-Line Reference for Windows 2.0

The Windows Guide from Bacchus & Smith gives you a technical reference guide for Microsoft Windows 2.0 that you can call up at any time from the DOS command line or from inside your favorite text editor by pressing the Shift-F1 hot key.

You get information on all Microsoft Windows 2.0 routines, with sample code, cross-referenced to related routines and information. You also get descriptions of the commonly encountered data structures in Microsoft Windows 2.0 programming, cross-referenced to the routines that use them. In addition, the Guide explains the various Microsoft Windows 2.0 messages, window styles, and mapping modes.

The Windows Guide requires the Norton Guides programmer's utility (which takes up 70K bytes) running on an IBM PC with DOS 2.0 and a hard disk drive.

Price: £47.

Contact: Bacchus & Smith Ltd., Farm Rd., Henley-on-Thames, Oxfordshire RG9 1EJ, U.K., 44-0491-576171.
Inquiry 963.

A Fax Card with Its Own CPU

CompuFax is a unique, full-length fax card, according to KCM Computers. Its Intel 16-MHz 80C88 CPU, backed with 512K bytes of RAM (expandable to 1024K bytes), gives you true background-mode operation and real-time foreground tasking. The combination also lets you network faxes on most popular LAN systems when you use CompuFax with software like FaxNet.

In addition to a built-in scanner interface, CompuFax offers a dedicated fax interface that lets you plug it into a Group 3 fax machine. The interface also lets you use the fax machine as a data scanner and network it using the FaxNet option.

You can piggyback a Hayes-compatible modem to the CompuFax board and transfer data at speeds of 2400 bps, 1200 bps, 300 bps, and 1200 bps Prestel standard speed.

Optional software enhancements include CompuLine, which gives you line-cost analysis for a breakdown of fax-transmission costs by department and by individual user; SecureFax, a security encryption package; and Fax-Mail, which gives you mailbox facilities. CompuScreen is a real-time application software package that lets you write in a sensitized screen or tabloid and send faxes in real time. The company plans to release these software packages in November.

You can install multiple CompuFax boards in an IBM XT, AT, or compatible. The optional CompuNet software lets you set up a matrix of computers with multiple CompuFax boards; it ensures that if one of the computers malfunctions, the next available computer takes over the load. CompuNet runs under the Novell LAN operating system version 2.12.

Price: \$1238 Australian for the CompuFax board with 512K bytes of RAM, front-end software, a user's manual, and a 12-month warranty; \$149 Australian each for CompuLine, SecureFax, and Fax-Mail; \$240 Australian for CompuNet software for up to five users.

Contact: KCM Computers Pty. Ltd., 380 Victoria St., Richmond, 3121 Melbourne, Australia. 61-03-429-2733.
Inquiry 960.

continued

Get A "Tailored" Copam System To Fit All Your Needs!

SYSTEM 286M

Usually people judge the ableness of something by its size. But don't let the slim style of our SYSTEM 286M fool you. This high-tech computer has an all-in-one mainboard that includes:

CPU: 80286-12, 0 wait state
DISPLAY: Monochrome, CGA
RAM: 1/2/4MB
DISK DRIVES: two FDDs or one FDD + one HDD
I/O PORTS: one PARALLEL + two SERIAL ports

Everything you see above, and much more, has been compacted into one single mainboard to remain conveniently uncomplicated for any type of user.

SYSTEM 386SX

Copam's SYSTEM 386SX is for the user that demands a high-performing 32-bit system at a competitive price. Utilizing Intel's P9 chip set, this system can support Microsoft's MS-DOS and OS/2 operating systems as well as complicated 386 application software. The SYSTEM 386SX can also use various displays (Mono / CGA / EGA / VGA) and allows you to choose from a wide range of RAM modules (1/2/4/8/16MB, 8MB on the system board). To sum it all up, the SYSTEM 386SX gives you flexibility and leaves you plenty of room for future growth.

Contact one of the offices listed below for more details.

- B.G. Diffusion
22 Rue Saint Jean de Dieu
69007 Lyon, France
Tel: 78698000
Fax: 72729454
- Beta Computer Systems Aps.
Frichsvej 40
DK-8600 Silkeborg, Denmark
Tel: (45) 6826100
Fax: (45) 6800222
- Clone AG
P.O. Box 105
CH-5400 Ennetbaden
Switzerland
Tel: (41) 56 21 26 0ff
Fax: (41) 56 22 08 46
- Copam Elec. Europe GmbH
Heerdter Landstrasse 193
4000 Dusseldorf 11
West Germany
Tel: (211) 501158, 507038
Fax: (211) 503591
- Copam Elec. Singapore Pte. Ltd.
#05-03 Delta House
No. 2 Alexandra Road
Singapore 0315
Tel: (65) 2739966
Fax: (65) 2735044
- Cotronic Computer Electronic
DR. Haschi-Weg 6
A-8054 Graz, Austria
Tel: 316 294988
Tlx: 311880 CONTR A
- Datavarehuset AS
Prof. Birkelandsvei 26
1081 Oslo 10, Norway
Tel: (47) 2 321025
Fax: (47) 2 327084
- Eionex (UK) Ltd.
Rays House, North Circular Road
London NW10 7XB
United Kingdom
Tel: (01) 9653225
Fax: (01) 9653246
- IMP-Data AB
Box 19137, S-104 32
Stockholm, Sweden
Tel: (46) 8317710
Fax: (46) 8342822
- Jen Electronica S.R.L.
Zona Industriale Enrico Fermi
62010 Montalupone (MC), Italy
Tel: (0733) 586423
Fax: (0733) 588890
- OY Genine AB IMP-Data
Ylipistonkatu 37
SF-20100 Turku, Finland
Tel: 35 (821) 335700
Fax: 35 (821) 516340
- Simac Data B.V.
High Tech Park, 5503 HP
Veldhoven, Netherlands
Tel: (040) 582933/582654
Fax: (040) 582707

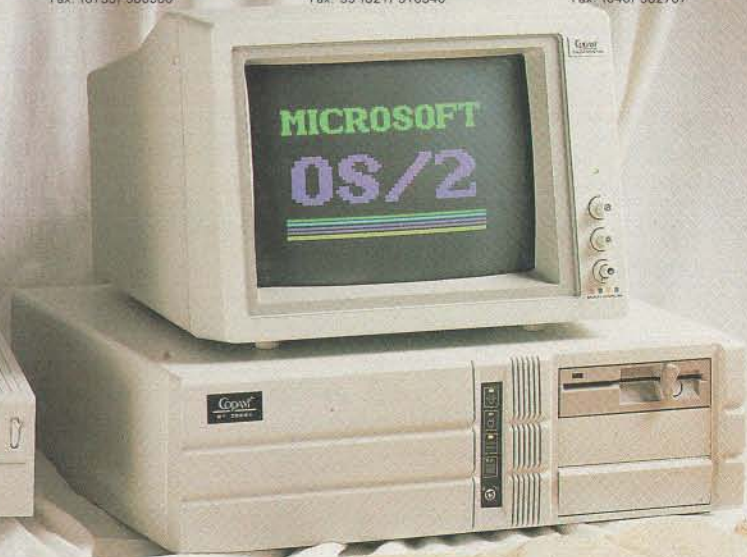

see us at:

COMPUTEX
TAIPEI '89
June 6-12, 1989
STAND A626-632
A825-831

COPAM

COPAM ELECTRONICS CORP.

5/F, 125 Nanking E. Road
Sec. 5, Taipei, Taiwan, R.O.C.
Tel: (02) 7640736
Fax: (02) 7695500

COPAM, SYSTEM 286M, SYSTEM 386SX, Microsoft, MS-DOS, OS/2, Intel, CGA, EGA, VGA, are registered trademarks.

“We have just finished our first Multi-Lingual Scholar™ produced job — a service manual in Russian for SAAB Marine Electronics. The result was quite good and the customer is satisfied. It seems we cut his costs some 30%.”

— TEKNISK SPRÅKSERVICE
Västra Frölunda, Sweden

SOFTWARE THAT SPEAKS YOUR LANGUAGE

Multi-Lingual Scholar™, a single software program for wordprocessing and high quality printing with multiple languages in the same document. Supports on-screen foreign characters — with accents and vowel points — with no hardware modifications. Arabic, Farsi and Hebrew edit right to left, and a font editor lets you design your own characters and customize keyboard layouts.

- Standard package includes 5 alphabets: Roman (for English, European and Scandinavian languages), Arabic/Farsi, Cyrillic, Hebrew and Greek. Supports 9-pin and 24-pin dot matrix printers. \$350 + \$20 s/h
- Also available with Hindi (Devanagari) replacing Hebrew. (Laser Printer option, \$150 additional)

- Laser Printer option, \$150 additional.
- Optional languages available: Armenian, Amharic, Sanskrit, Indian dialects, Syriac and most ancient Biblical languages; please inquire.

- Demo program — same as standard package except file size and printing have been limited. Comes with tutorial. \$15 (applies toward purchase) + \$7 s/h.

Multi-Lingual Scholar

A product of
Gamma Productions, Inc.

710 Wilshire Boulevard, Suite 609
Santa Monica, CA 90401 USA
Tel. 213-394-8622
Tlx: 510 600 8273 Gamma Pro SNM

Requires: IBM PC/XT/AT or compatible, 640K, graphics (Hercules CGA, or EGA), 1 disk drive, 1 parallel port. Works with most dot matrix (9- and 24-pin) printers and Hewlett Packard Laserjet+/Series II or compatible laser printers.

VISA/MC/AMEX,
or bank draft
in US dollars
accepted. Or write
for a list of
dealers
world-wide.

Pinpoint LAN Cable-Fault Locations

The Comtest Cable Scanner from M-Trade is an easy-to-use keyboard and display that quickly pinpoints the location of cable faults and breaks on a LAN so you can eliminate breakdowns and decrease downtime.

Using the Time Domain Reflectometry method, the Cable Scanner locates problems by sending a signal through the cable and measuring the time it takes for the signal to return. In addition, it measures cable resistance (terminators), noise level (interference), and network activity, and it can help you determine when it is time to buy a bridge or add a repeater to your cabling system.

The device is preprogrammed for Ethernet, ARCnet, Token Ring, StarLAN, Twisted Pair, AppleTalk, and TOPS, but you can program it for any kind of cable, including cable TV and telecom networks. The 32-character display reports the fault location, and you can print a hard copy of the report on any RS-232C serial printer or save the results in the Cable Scanner's memory for later review.

With the Comtest Cable Scanner you get the Cable Tracer/Sender, which helps you locate exactly where in the ceiling, floor, or wall the cable lies and what type of cable it is—coaxial, twisted-pair, or something else. You connect the Cable Tracer's sending unit to the wire or cable and run the receiver unit over the areas where you think the wire may be located. The Cable Tracer/Sender sounds an alarm when its receiver passes over the wire, pinpointing the



M-Trade's Comtest Cable Scanner helps eliminate LAN breakdowns and downtime.

wire's exact location.

M-Trade also offers the Cable Checker, which tells you if LANs or cables are in working order. It tells you if cables have shorts or breaks, and it can help you determine which lead going into a wall or floor is connected to which lead coming out.

Price: £1295 for the Comtest Cable Scanner Kit; £175 for the Cable Tracer/Sender Kit; £54 for the Cable Checker Kit. **Contact:** M-Trade (U.K.) Ltd., 11 Northfields Prospect, Putney Bridge Rd., London SW18 1HR, U.K., 44-01-877-1711.

Inquiry 951.

A Software Development Tool for Prolog

Based on Prolog, CIM-Prolog is a software development tool that includes an incremental Prolog compiler/interpreter, a versatile debugger, and a multiwindow text editor.

The software includes a graphics subsystem that supports multiwindow operations, auto-refresh of windows,

continued

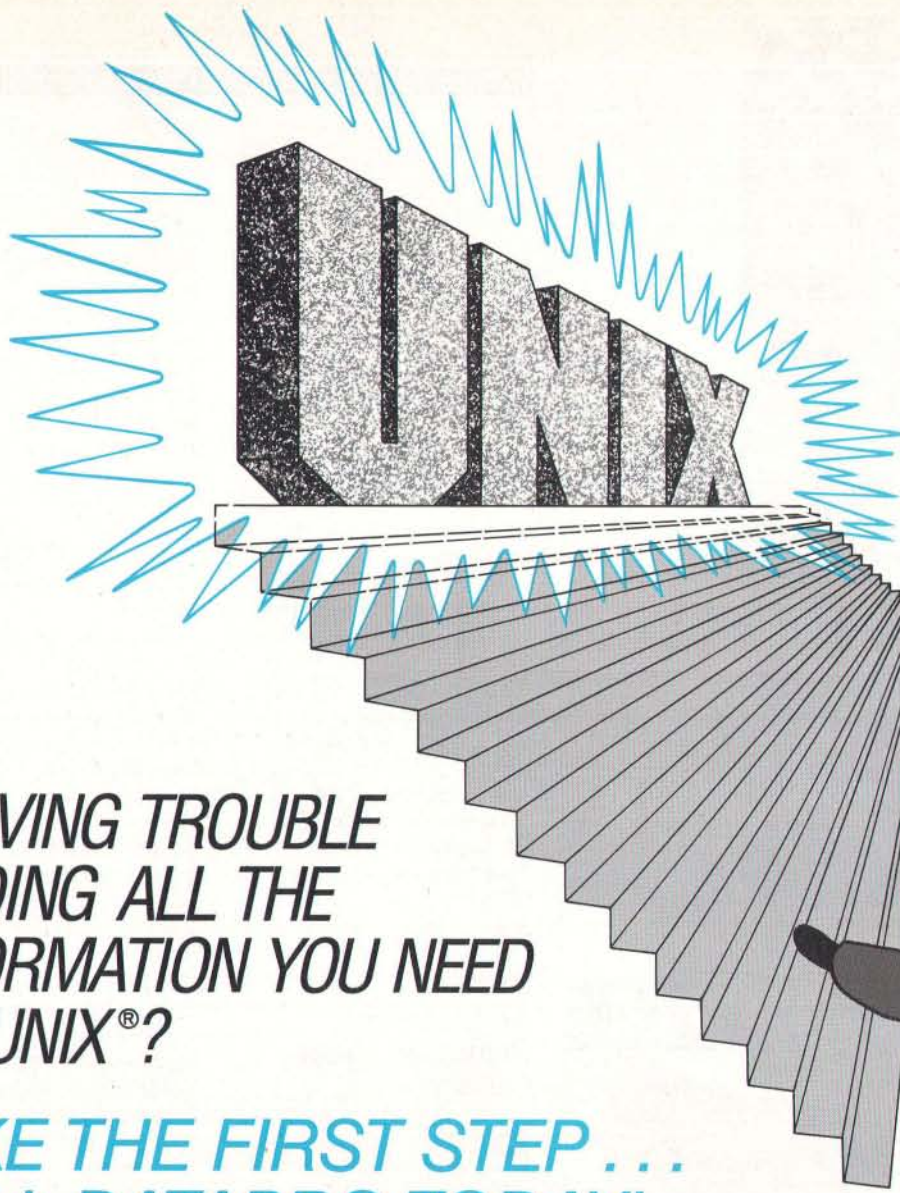

HAVING TROUBLE
FINDING ALL THE
INFORMATION YOU NEED
ON UNIX®?

**TAKE THE FIRST STEP ...
CALL DATAPRO TODAY!**

If you're looking for detailed analysis of the critical issues surrounding UNIX . . . if you need timely information on the products and key players in the industry . . . then turn to Datapro Reports on UNIX Systems & Software.

Updated monthly, this unique new information service is designed to help you discover the opportunities UNIX offers . . . decide how UNIX fits in your organization . . . optimize results while minimizing risk.

Each month, Datapro Reports on UNIX Systems & Software brings you in-depth analyses of every-

thing new and noteworthy in the UNIX market. You receive the most up-to-date, thoroughly researched information available. Information you can put to use in planning your own UNIX strategies.

Find out how much of a difference Datapro can make to your decision-making: call us today at **1-800-DATAPRO** (1-800-328-2776) or use the reader service card.

UNIX® is a registered trademark of AT&T.

datapro®





IEEE488

Technology that hits the mark

- For IBM-PC/XT/AT/386, IBM-RT 6150, IBM-PS/2, PHILIPS :YES and all compatibles
- For MS-PC-DOS, OS/2, and UNIX
- Extremely fast and easy to use software
- All HP-IB commands (ONSRC etc.) are implemented
- Compatible to ASYST, AutoCad, National Instruments, CEC etc.
- Real time error checking and bus analysing
- Supported Basic (compiled), Turbo-Basic, (Turbo-) Pascal, Modula-2, Fortran, C, Turbo-C, Assembler etc.
- Available in English, French and German
- Analysing software for instruments



Dealer + OEM welcome

Ines GmbH
Neuenhofer Allee 45
5000 Köln 41
West-Germany
Phone: 49 - 2 21 - 43 86 59
Teletex: 25 27 2 21 4237 girkin
FAX: 49 - 2 21 - 49 38 71

and data structures that you can easily modify. Other features include a foreign-language interface, a module system, a garbage collector, support for single- and double-precision floating-point numbers, installable device drivers, multinode operation on Apollo Domain nodes, and documentation in English and German.

CIM-PROLOG is available for the Apollo Domain, the IBM PC, and the Atari ST. **Price:** 4900 deutsche marks for the Apollo Domain version; 298 deutsche marks for the IBM PC and Atari ST versions.

Contact: Creative Soft, Harald König GmbH, Postfach 13 15, D-8510 Fürth/Bayern, West Germany, 49-09-11-749-9214.

Inquiry 953.

formation; and the pictorial information.

Your text items can be up to 32K bytes, and, using most word processors and optical-character-recognition systems, you can create plain ASCII files that Pigalle can accept and append to the database. A built-in text editor lets you enter data from the keyboard or modify existing text files before appending them to the database.

Displaying monochrome or low-resolution color pictures and entering monochrome images requires a frame grabber or an RGB monitor as additional hardware. With this configuration, you can display up to 256 colors on-screen simultaneously. You can input and append black-and-white pictures to the database using a monochrome video camera.

Pigalle requires an IBM PC with 640K bytes of RAM and DOS 2.0. The company recommends an IBM AT or 80386-based computer. Image-intensive applications require a large-capacity hard disk drive or an optical disk drive. If you use a 200-mega-byte WORM (write once, read many times) drive, it can accommodate approximately 3000 color pictures, 6000 monochrome pictures, or 1000 A-4-size drawings.

Price: 2475 deutsche marks.

Contact: Szki Computer Research and Innovation Center, 1015 Budapest, Donáti u. 35-45, Hungary, 36-1-35-01-80. **Inquiry 962.**

A Turbo Pascal-to-C Translator

Lauer & Wallwitz, who wrote Borland's Turbo Pascal Graphics Toolbox, offer a Turbo Pascal-to-C translator in German called P2C. The translator will take

continued

An Electronic Picture and Text Gallery

Pigalle, which stands for electronic picture and text gallery, integrates large-volume, free-format, textual and pictorial information into a database. The system uses database-handling and image-compression algorithms that offer you services previously available only on mainframes, according to Szki.

You can use Pigalle to maintain product catalogs; to file and combine X-ray or ultrasonic images with additional information to support medical diagnoses or to build up client histories; to create educational materials; to edit and publish encyclopedias, almanacs, and monographs; and to catalog and archive objects in museums and galleries.

The database is made up of three units: the Knowledge Base, where you define the structure of the other parts of the database and the relations between them; the textual in-

技 GA-386L 嘉



GA-386LC

1. C&T 82C307 32-BIT CACHE/DRAM CONTROLLER
2. 32KB (4Kx4) SRAM CACHE MEMORY
3. 25/20MHz 0/1 WAIT STATE
4. 80287, 80387, WEITEK SCOKET ON BOARD
5. 32 BIT 4MB/16MB DRAM MODULE ON BOARD (FIRST 2MB/8MB 32 BIT RAM/2S/2P CARD REPLACE RAM MODULE)
6. HW & SW SPEED CONTROL
7. BUZZER ON BOARD
8. Legal BIOS
9. OS/2, WINDOW/386 UNIX, PC MOS386

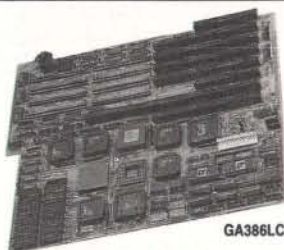

GA386LC

GA-386L MAIN-BOARD

- Intel 80386 32bit CPU
- System speed 16/20 MHz 0 wait state or 20MHz/24MHz switchable 0 wait state Land Mark Speed-32MHz.
- Hardware/software speed control
- 80387/80287 optional
- 1 slot for 32 bit, 5 slot for 16 bit 2 slot for 8 bit
- Rechargeable battery, Turbo LED hard reset built in
- BUZZER ON BOARD.
- 1/2/4/8/10/16M BYTE Optional
- 41256 & 1M Bit DRAM Suitable
- OS/2, WINDOW/386 UNIX, pcos 386
- Page interleave.
- Legal BIOS (AMI WDIAG)

GA-386M 8MB I/O MEMORY CARD

- 8MB I/O memory CARD.
- 2MB/8MB DRAM Optional
- 2 Serial/2 Parallel Port ON CARD
- 41256/1M Bit DRAM Can Be Used

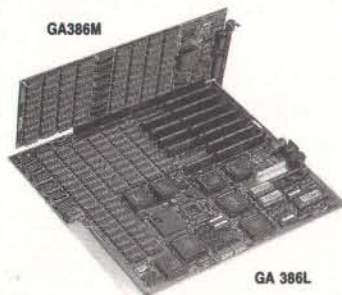

GA 386L



GIGA-BYTE
ENTERPRISE CO., LTD.

3rd FL., No. 46, Min Chuen Road, Hsin Tien, Taipei, Taiwan, R.O.C.
TEL: (02) 918-4839
FAX: 886-2-9184842
TELEX: 35342 GIGABYTE



MegaOne. MegaFour. Your Compaq Computer Memory Solutions.

You require maximum performance. Now you can achieve the performance you expect from your COMPAQ® system.

That's why Micron developed our MegaOne™ and MegaFour™ Memory Modules—to provide optimum utilization of the high performance features of your 386™ series of COMPAQ personal computers.

Micron MegaOne and MegaFour boards increase the total system memory up to 16 megabytes in a single slot. And their 32-bit architecture can be used in your COMPAQ system running at 16, 20 or 25 MHz for maximum performance with today's most sophisticated software.

The Mega series is fully interchangeable with COMPAQ

Memory Modules. So you have complete flexibility when designing your memory solutions.

Like all Micron memory products, our MegaOne and MegaFour Modules are manufactured and tested under the industry's most stringent quality control standards. Plus they're supported by our service and warranty program.

So choose the Mega Memory solution for your COMPAQ system by calling Micron at 01-959-3611.

Micron. It's a name worth remembering.



MegaOne and MegaFour are trademarks of Micron Technology, Inc. COMPAQ is a registered trademark of Compaq Computer Corporation. 386 is a trademark of Intel Corp.

MICRON

TECHNOLOGY, INC.

European Office: Trafalgar House, Grenville Place, Mill Hill, London W7 3SA Phone: 01-959-3611, FAX: 01-959-6168

UNITED KINGDOM
Midwich Thame Ltd
Phone: 0379-644131
Softsel
Phone: 01-568 8866

FRANCE
Softsel
Phone: (1) 43 34 97 35

BELGIUM
MCA-Tronix SPRL
Phone: 041 674208

DENMARK
Henckel Elektronik
Phone: 03-906333

NORWAY
BIT Elektronikk A.S.
Phone: (03) 847099

SWEDEN
GATEline AB
Phone: 08-778 4440

SWITZERLAND
Anatec AG
Phone 0424-41 24 41

WEST GERMANY
DNS GmbH
Phone: 08142-18016
Stening Electronic GmbH
Phone: 02482/609E

Circle 428 on Reader Service Card

BBS Sysops

Are you looking for ways to improve your board? Something that will set you apart from other boards in your area?

Are your subscribers interested in Microcomputers?

Listen to this!

Announcing the Bulletin Board EXchange - BBX

The BBX allows you to become a publisher of MicroBYTES Daily, an on-line news service from BYTE. BBX/MicroBYTES is a custom package of news and features designed specially for local BBSes, and is available only to sysops.

Every Monday through Friday you get articles about developments in microcomputing, telecommunications and selected new product announcements. Get the latest news about MS DOS machines, Macintoshes, Unix workstations, Amigas, Atari STs, peripherals and software. All the stories are reported, written, and edited by the staff of BYTE Magazine, BYTEweek and BIX, and our world-wide network of reporters and editors.

Not only do you get a great resource for your subscribers, but you also get access to BIX which will cut your cost of exchanging information and conducting BBS network business.

All this is just \$49 a quarter.

Your one-year subscription to the BBX (billed quarterly) may be cancelled any time without further charge; just notify us. If you prefer, you may subscribe for three months only, at just \$69.

If you call BIX directly, you pay no hourly telecommunications charge. If you call using Tymnet, the rates are only \$2/hour on evenings and weekends and \$8/hour on weekdays. You may also purchase unlimited off-peak Tymnet for just \$15 a month.

Subscribe Today.

BIX

One Phoenix Mill Lane
Peterborough, NH 03458
1-800-227-2983
In NH (603) 924-7681

any Turbo Pascal listing (versions 3, 4, and 5) and convert it to Microsoft, Turbo, or ANSI C source code.

P2C is a three-pass compiler, which performs a syntactical analysis and automatically handles the basic structural differences of Pascal and C with a few basic exceptions; the translator does not support binary-coded decimal arithmetic. It converts Pascal in-line procedures into C comments, and graphics routines into their equivalent Turbo C counterparts.

The translator includes a library that converts Pascal routines, such as string and set operations, to equivalent C routines. According to the developer, you can compile and run a majority of Turbo Pascal programs in Turbo or Microsoft C after processing with the P2C compiler.

P2C is particularly useful for programmers who want to port their Pascal applications to Unix systems, which are better suited to running C than Pascal.

Price: 500 deutsche marks.
Contact: Lauer & Wallwitz, Kirchgasse 24, D-6200 Wiesbaden, West Germany, 06121-42771.

Inquiry 974.

New Zealand Unix Systems Users Group

The aims of the New Zealand Unix Systems Users Group are to share information about Unix-based computer operating systems, their look-a-likes, and related hardware and software; to distribute computer software and related documentation; and to develop the Unix market.

The NZUSUGI has direct affiliations with several overseas groups, including USENIX and those from Australia (AUUG), Singapore

(SINX), Korea (KUUG), Japan (JUS), and Europe (EUUG). Benefits to members through these affiliations include an exchange of newsletters, free conference registration for a representative of the affiliated group, and reduced registration fees for other group members.

Contact: Malcolm Stayner, President, c/o ICL New Zealand Ltd., P.O. Box 394, Wellington, New Zealand, 64-4-724-884.

Inquiry 946.

High Security for Your Macintosh

According to HighWare, its FileGuard automatic file-protection software is the solution to all the security problems on your Macintosh.

The software helps you protect documents against unauthorized access and prevents accidental deletion or illegal copying of your files. It also prevents destructive computer viruses from entering your computer system.

When you save a new document, FileGuard automatically intervenes and offers you the option of encrypting it. When you open a protected document, FileGuard requests the password for decryption and then launches the application that created the document. When you leave your application, FileGuard re-encrypts your document without any intervention on your part.

In addition to the auto-encryption functions, FileGuard offers complete document-access management and surveillance. It determines the document-access authorization for each user and also grants or refuses use of certain basic functions, such as opening, creating, saving, and deleting documents. For each

continued

The top software protection in Germany is looking for distributors with their eye on the top notch in Europe.



What made us number 1 in Germany ...

To reach the top spot in a market as hard to conquer as Germany it took a product as tough as Hardlock. To create a product as tough as Hardlock, it took a company with a soft spot for software protection. Selling over 120.000 copies of Hardlock would have satisfied many others. Not FAST Electronic. Our team is young, able and willing to perfect the technique of hardware based software protection. And the new Hardlock E-Y-E comes as close to perfection as you can possibly get.

... will make us number 1 in Europe...

We are now even further ahead. The new Hardlock E-Y-E is based on a chip developed by FAST Electronic for the sole purpose of protecting software. Hardlock E-Y-E is cryptoprogrammable. You, the software developer, are the only one to program Hardlock E-Y-E. This gives you greater flexibility in protecting your program options. 128 bytes of data can be optionally stored in the new Hardlock E-Y-E. Use HL-Crypt, the automatic implementation program, to protect your .COM and .EXE files within seconds. Query routines for customized implementations are available at no extra charge for all the major compilers.

... with you the distributor as its leading edge.

Each product is only as good as the people selling it. If you're fast enough to keep abreast of the ambitious team which makes up FAST Electronic, don't hesitate to give us a call. We're eyeing distributors willing to head straight for the top. With a product which already deserves to be there. Personal commitment and energy will be the decisive factors. This doesn't mean that a little knowledge of the software trade would hinder your chances to accompany FAST Electronic on its way to the top.



Hardlock E-Y-E – custom chip for software protection.

FAST

Fast Electronic GmbH

Contact Mathias Vaagt at

FAST Electronic GmbH, Kaiser-Ludwig-Platz 5, D-8000 München 2, West Germany, Tel. 0049/89/532653, Fax 0049/89/533401

INTRODUCING BYTE's

Direct Response International Postcards

From the most prestigious microcomputer magazine comes a new and inexpensive direct response medium—a postcard advertising insert bound into the highly respected International Section of *BYTE Magazine*, called *BYTE's International Direct Response Postcards*.

Postcard ads provide a direct-response vehicle that encourages prospects to respond to offers for information as well as direct sales. A postcard ad is versatile because it allows you to test your product to potential buyers. That's because you can use your card to sell computer products, generate leads, conduct market research or sell books and periodicals. Each postcard is perforated so it can be easily torn out and returned directly to you without any intermediary—guaranteeing leads that are current and "hot."

Expand your horizons into this valuable marketplace.

The Pan-European marketplace is preparing to open up to greatly expanded trade in 1992 with the breaking down of trade restrictions. And *BYTE's International Direct Response Postcards* presents the perfect opportunity to test your product in this marketplace and to get your company positioned in the minds of the major buyers.

These unique advertising postcards which will be inserted into the International Section will reach 70,000 influential *BYTE* paid readers throughout Europe.

In Europe, contact:

Karen Lennie or

Roz Weyman (German-speaking)

at (01) 493-1451

McGraw-Hill Publications

34 Dover Street

London W1X 4BR

England

protected file, FileGuard maintains surveillance and keeps a record of all operations performed, including user's name, date and time of creation, opening and closing documents, and attempts at unauthorized access.

FileGuard is accessible at all times in a new menu or through the Control Panel. It runs on the Mac Plus, SE, and II.

Price: \$249 U.S.

Contact: HighWare, Avenue Henri Jaspar 109, B-1060 Brussels, Belgium, 32-2-2537-6810.

Inquiry 967.

ICA Lawyers' SIG

Founded in 1984, the International Computing Association (ICA) has developed into an organization with hundreds of members and supporters all over the world using most types of computers.

The latest chapter is the Lawyers' Special-Interest Group (SIG). Subjects include law databases, computers for the legal profession, information and software for lawyers, computer-related laws, data protection, and computer security.

Besides having access to regular ICA activities, every ICA member can join one or more SIGs in the ICA at no extra cost. The group stores its newsletters and special reports on IBM-formatted disks and airmails them to members free of charge.

The initial subscription fee for new members is \$25. Annual dues are \$9.

Contact: International Computing Association, Lawyers Special-Interest Group, c/o Markus H. Maegge, Roebek 6, 2000 Hamburg 52, West Germany, 49-40-82-14-20.

Inquiry 945.

Keep Your Floppy Disk Drives Clean

The Trackmate Disk Drive Care System is more than a cleaner: Its software includes drive diagnostics and a report generator that gives you monthly reports on diagnostic and cleaning activity by floppy disk drive.

The menu-driven software tests to see if cleaning is necessary and, if so, recommends the length of the cleaning program. It diagnoses key drive functions, such as head condition, and automatically manages the cleaning process.

A marker pen delivers isopropyl alcohol. Flexible absorbent brushes carry the solvent to the dirt, dissolving it, and then reabsorb the waste. The brushes form-fit the read/write heads to seek and remove dirt from the component surfaces, grooves, and gaps. Additional brushes clean the loading rails.

The Trackmate Disk Drive Care System comes in four versions: the Model TM551 for 360K-byte 5¼-inch drives in IBM PCs and compatibles; the Model TM541 for 1.2-megabyte 5¼-inch drives in IBM ATs and compatibles; the Model TM561 for 720K-byte and 1.44-megabyte 3½-inch drives in IBM PCs and compatibles; and the Model TM571 for Apple Macintosh drives.

Price: £19.95 for the TM551; £24.95 each for the TM541, TM561, and TM571.

Contact: Work Environment Systems Technology (WEST) Ltd., Unit 9, I.D.A. Enterprise Center, East Wall Rd., Dublin 3, Ireland, 353-01-788955.

Inquiry 918.

continued

Now available
for 386 UNIX/Xenix!

In a Noisy World...

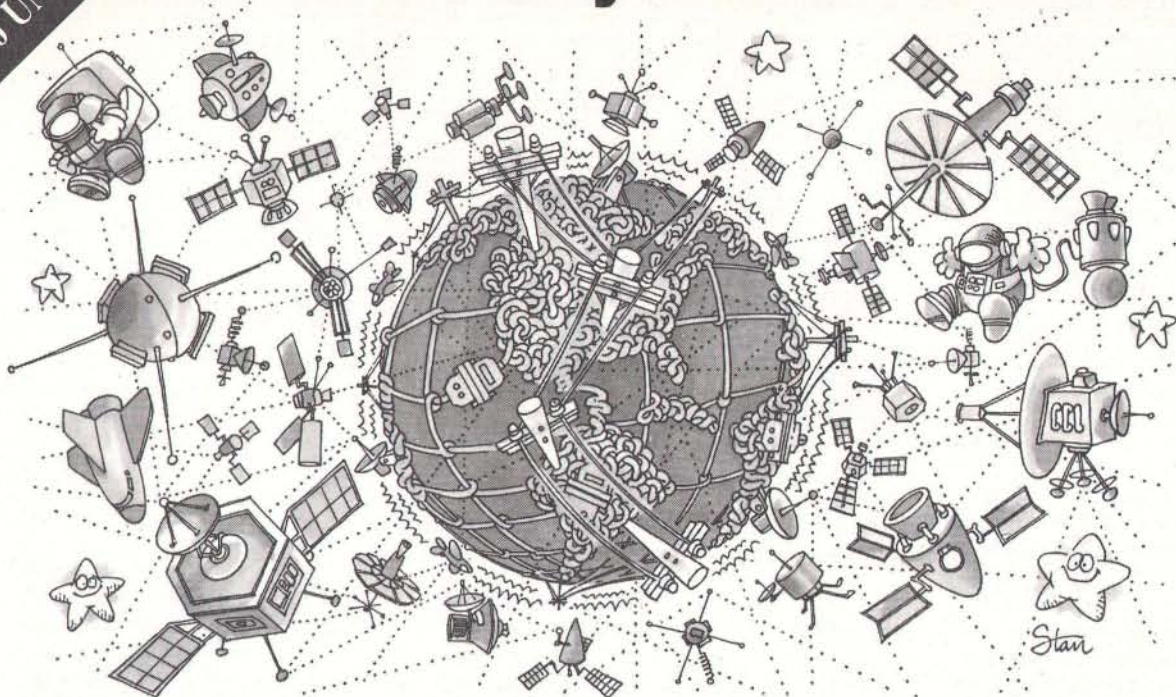

BLAST Communications Software Gets Your Data Through it All!

Performance with increasing noise.

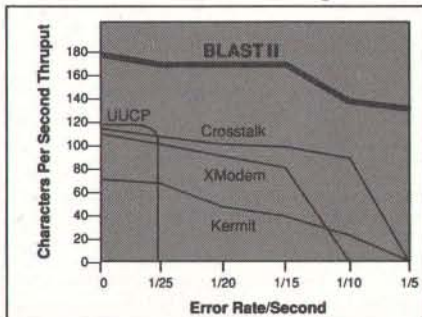

Noise simulation tests run with a 30K binary spreadsheet file at 1200 baud between IBM-PC's, using BLAST II, rev. 8.1. Comparable or better results on Mac, VAX, and others.

In today's world of noisy phone lines, complex switches, and satellite-routed calls, you need rugged communications software to get your data safely through everything, everytime.

BLAST's protected pipelining protocol won't slow to a snail's pace, drop data or disconnect due to noise. Static interference or PBXs — your valuable data quickly BLASTS through it all, saving you time and money, *without any add-on boards or other expensive hardware*. And, BLAST is X.25/DECNET/MNP compatible!

Link VAXs, PCs, MACs, and UNIX/Xenix anywhere

BLAST guarantees fast, 100% error-free file transfer and terminal emulation to connect PCs, MACs, UNIX/Xenix, minis and mainframes. With BLAST II you have *one* easy-to-use interface, *one* set of commands, *one* protocol, and *one* scripting language.

Auto-dialing and modem management sequences are built-in so you can easily set up polling, data collection, order entry and other *unattended* communications applications between *hundreds* of remote sites, all at a fraction of what you'd expect to pay. Plus, a "Lock & Key" network feature locks out unauthorized users.

The Choice of the Fortune 1000

Bankers Trust, Blue Cross, Exxon, Nabisco, and many others have chosen BLAST to cut through the noise. And now, leading communications products vendors specify BLAST, as well. Find out what BLAST can do for you. Give us a call today.

Any computer with BLAST can talk to any other computer with BLAST:

IBM	VM/CMS or MVS/TSO
DEC	VAX/VMS; PDP/RX; RT-11
DATA GENERAL	RDOS; AOS; AOS/VS
WANG	VS
PRIME	PRIMOS
HEWLETT-PACKARD	3000/MPE; 1000/RTE
HARRIS	VOS
TANDEM	LXN
UNISYS	BTOS, CTOS, UNIX
IBM-PC & PS/2	MS-DOS
APPLE	MACINTOSH
UNIX/XENIX	AT&T; Altos; NCR; Sun HP; VAX & mVAX; 386 PCs.

Many others available; please inquire.



BLAST®

Communications Research Group

5615 Corporate Boulevard
Baton Rouge, Louisiana, USA 70806
(504) 923-0888

© Copyright 1989, Communications Research Group, Inc.

Circle 405 on Reader Service Card

International Distributors:

- Belgium 32-2-347-3543
- Canada 613-523-7272
- France 33-1-3054-2222
33-1-6930-7172
- Great Britain 44-01-987-9021

- Germany 49-89-480000-0
- Italy 39-2-837-8341
- Mexico 525-250-9632
- Netherlands 31-20-970343

- Japan 81-03-5025550
- Australia 61-03-5282711
- Portugal 351-1-658406
- Sweden 46-08-7344000

Current Loop-to-V.24/RS-232C Communication

The Databox Current Loop Adapter (CLA) permits data-communication equipment using current loop transmission to communicate with equipment using V.24/RS-232C interfaces. A front-panel switch lets you select active or passive operation on the current-loop interface, and the transmit and receive interfaces are protected by opto-couplers. The power supply is isolated from the chassis.

Price: 400 Swiss francs.

Contact: Databox S.A., 48, route des Acacias, CH-1227 Geneva, Switzerland, 41-22-42-21-30.

Inquiry 970.

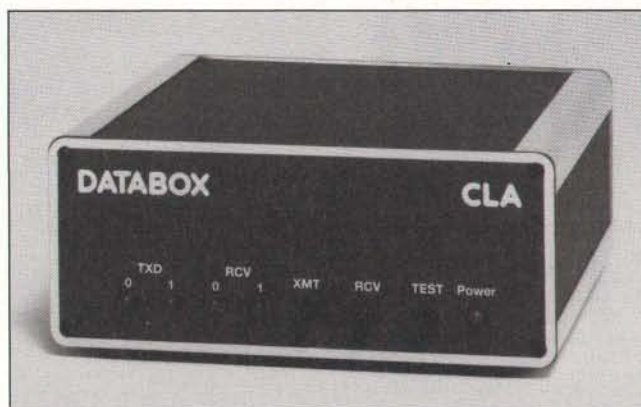

The CLA lets current-loop and V.24/RS-232C interfaces communicate.

Record Electrical Irregularities

You can monitor power lines and detect and record electrical irregularities with the Power Line Re-

recorder and use the information you obtain from the device to determine the causes for equipment damage and the interruption of data processing or manufacturing processes.

Monitoring line voltages and frequencies, the Power Line Recorder detects and

records peaks, surges, and interrupts in two classes: HF (slow rate above 50V per μ s) and LF (slow rate below 50V per μ s).

The Power Line Recorder contains a built-in, crystal-controlled clock/calendar, which automatically calculates leap year and daylight saving time. The unit's memory, capable of storing 600 separate power-irregularity events, is expandable to 2000 records.

You can connect the Power Line Recorder directly to a printer through its RS-232C interface for simultaneous printout of events, or you can store the data in the unit's battery-protected memory for later uploading to a microcomputer. You can also import the data, which is time-tagged

continued

FORTTRAN

Q · T · O · O · I · S

SYSTEM SOFTWARE LIBRARY

- the software library with the complete system interface: access to all MS/PC-DOS and BIOS services, control on all PC/XT/AT system units like keyboard, video, disk, memory, RS232C, printer port, real time clock etc. (see BYTE 12/88, 96IS-12)
- versatile routines for string handling and sorting
- 300+ functions compressed in 200+ routines
- comprehensive 460-page manual in English
- no royalties

Available for MS/FORTTRAN (Microsoft) 4.xx and RM/FORTTRAN (Austec/Ryan-McFarland) 2.1+ (specify!). Prices in Deutsche Mark (shipping incl.): QTools DM 720.00, QTools Demo Package (3 diskettes, incl. source) DM 20.00. We accept VISA, Master, Eurocard, Access and Dinners, or prepayment.

QT software Ungerstr.108
8000 München 40 W.-Germany
Tel. 0 89/36 91 49

Circle 438 on Reader Service Card

IBM-PC BUS Input/Output Cards

- DIP-24 Opto-isolated digital input
- DOP-24 Opto-isolated Darlington output
- PIO-48 TTL level digital input/output
- DPC-10 Pulse counter/timer/generator
- DCM-16 8 Inputs, 8 Outputs, CTC
- AIP-24 12 Bit ADC input
- AOP-8 12 Bit DAC output
- AIS-16 12 Bit isolated ADC input
- TIP-8 Thermocouple input
- SIO-2 RS232/422/485/20mA I/O
- ST-24 Screw terminal adaptors
- BXT Backplane extenders
- BP-5/11 5/11 Slot backplanes

**BLUE CHIP
TECHNOLOGY**

Blue Chip Technology
Main Avenue, Hawarden Industrial Park
Manor Lane, Deeside CH5 3PP U.K.
Telephone: (0244) 520222
Telex: 61471 Fax: (0244)531043

Agents
Wanted

Circle 404 on Reader Service Card

THE ONLY THING WE'VE CUT...

OLIVETTI M280



Fast performer at a low price, with high quality design and wide flexibility.
 12 MHz 80286
 1MB Memory
 40MB Hard Disk
 Diskette options.
 EGA Mono screen.

£1495
 (60MB : £1650)

OLIVETTI M380/C

Why use a 386sx when you can have a full 386 system?
 Don't compromise - use the fast M380/C

1MB memory
 32 bit 80386 (16MHz)
 60MB (40ms) Disk
 VGA Mono screen

£2395



... IS THE COST.

APRICOT

Qi 350i 2MB + 47MB MCA 2399
 Qi 650 1MB + 47MB MCA 2799
 Qi 660 1MB + 65MB MCA 3249
 Qi 660i 1MB + 118MB MCA 4049
 Qi Environment 195
 Qi VGA White 190
 Qi VGA Colour 475

TOSHIBA

T1200 1MB 20MB LCD 1875
 T1600 1MB 20MB LCD 2495
 T3100 640K 20MB Plasma 2095
 T3200 1MB 40MB Plasma 2950
 T5100 2MB 40MB Plasma 3450

NEC

Powermate SX 2MB 42MB Multisync 2695
 Powermate 386/20 2MB 42MB Multisync 3095
 Portable SX 2MB 42MB Plasma 3095

OLIVETTI

M290 1MB 20MB Mono 1750
 M290 1MB 40MB Mono 1995
 M290 1MB 80MB Mono 3250
 XP1 1MB 80MB Mono 3750
 XP3 2MB 135MB Mono 4530
 XP5 4MB 300MB Mono 5395
 VGA Colour extra 275

£

2695

3095

3095

1750

1995

3250

3750

4530

5395

275

- Authorised Novell Dealer
- Epson Silver Centre
- Tandon Premier Dealer
- Authorised Hewlett Packard Dealer
- Authorised AutoCAD Dealer
- Authorised Lotus Dealer

For further information and a quotation on any products call our sales team today.

EXPORT SALES

Our export division specialises in supplying personal computer systems to customers throughout Europe, Africa and the Middle East.

These are just some examples of our huge product range. We also supply all major printers and peripherals, including network systems.

With UK prices lower than ever, more and more European users are buying direct.

Check the options for yourself straight away.

**MAYFAIR
 MICROS
 INTERNATIONAL**

Tel: +44.1.871 2555

Blenheim House, Podmore Road,
 London SW18 1AJ
 Tel: +44.1.871 2555 Fax: +44.1.871 9786
 Telex: 936066 MICROS G
 Circle 426 on Reader Service Card

to the millisecond, into databases, spreadsheets, or custom application programs.

The Power Line Recorder connects to the IBM PC, XT, AT, and compatibles through an RS-232C interface, and the software runs under DOS 3.0 or higher.

Price: \$1995 U.S.

Contact: Gantner Electronics, Batloggstrasse 42, A-6780 Schruns, Austria, 43-5556-3784.

Inquiry 921.

An IBM PC Card with AT&T's 25-MFLOPS DSP

The Vector 32C/256 is a plug-in card for your IBM PC that uses the AT&T DSP32C 25-MFLOPS digital-

signal processor (DSP). The processor can carry out a 1024-point complex floating-point fast Fourier transform (FFT) in 3.3 ms, according to SMIS. Applications for the card include math accelerators; graphics, array, and speech processing; image reconstruction and analysis; satellite communication; and radar and sonar analysis.

The card also features 256K bytes of high-speed static RAM, which you can address directly as program or data storage, and a 16-bit, 8-kHz coder/decoder. You use a phone socket or a nine-way D-type connector on the IBM backplate to connect the card to the coder/decoder. Two high-speed expansion ports connect directly to a variety of data acquisition and control cards.

Included with the Vector 32C/256 are a C-like assembler, a simulator, a debugger, and an applications library; an emulator is also available.

Three cross-compilers, BASIC, Pascal, and C, compile down to native DSP assembler code. In addition, you can call assembly language subroutines from these languages to facilitate time-critical applications.

SMIS also supports applications written in Microsoft C or FORTRAN by providing a host interface communicating with a library of DSP functions, such as FFTs, trigonometry, and integration.

Price: £1995.

Contact: SMIS Ltd., Alan Turing Rd., Surrey Research Park, Guildford, Surrey GU2 5YF, U.K., 44-0483-506611.
Inquiry 969.

A New AT-Class Computer from Commodore

The new PC 40-III computer system from Commodore Büromaschinen comes with improved features, a smaller case, a mouse interface, and a higher processing speed.

An on-board graphics adapter and video controller are integrated on the main board. In addition to MDA, MCGA, CGA, and EGA video modes, the PC 40-III also provides VGA with enhanced features.

The PC 40-III comes with an 80286 microprocessor that can operate at clock speeds of 6, 8, or 12 MHz. The com-

continued

Brian D. Hahn

True Basic

by Problem Solving

1988, XIV, 337 pages with 8 figures and 8 tables. Hardcover. DM 68.00. ISBN 3-527-26863-4

VCH Verlagsgesellschaft
Postfach 10 11 61
D-6940 Weinheim



Circle 444 on Reader Service Card



FORTH INSTRUMENTATION
COMPUTER

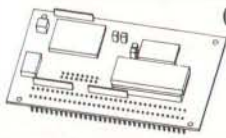

TDS 9090

A powerful control computer based on the new Hitachi 6303Y and high level language Forth. 100mm x 72mm. 30K bytes RAM, 16K dictionary RAM/PROM, 256 bytes EEPROM, 16K Forth. You can attach 64 key keyboard, LCD and I²C bus peripherals. Built in are interrupts, multitasking, time of day clock, watchdog timer, full screen editor and symbolic assembler, 32 parallel and two serial ports. Single power supply and low power 3mA OPERATIONAL mode.

1 off £194.95 including manual and non-volatile RAM.

Triangle Digital Services Ltd
100a Wood Street, London E17 3HX
Telephone 01-520-0442 Telex 262284 (quote M0775)

Circle 442 on Reader Service Card



Finally, there's an SQL that gets back to BASIC. And COBOL. And C. And Pascal.

As a programmer, you've probably already faced it—the database dilemma. Do you use an SQL for easy database handling, or a true programming language for maximum power and flexibility?

Now you can do both with XQL®, the relational data management system from the developers of Btrieve.®

The Programmer's SQL. With XQL, you can access your data with the ease of Structured Query Language through simple subroutine calls from traditional programming languages. XQL supports standard SQL syntax, including subqueries, unions and security groups.

XQL Relational Primitive Operations. In addition, XQL lets you bypass the SQL level and perform highly efficient, relational primitive operations directly. You get all the functionality of a relational database model without the constraints of a 4th generation language.

Building on Btrieve. The heart of Novell's family of data management tools is Btrieve. By letting you access multiple records at a time, XQL adds a powerful dimension to Btrieve. XQL incorporates sophisticated data manipulation features which

allow you to access data by field name, move forward or backwards through the database, compute fields from other fields or constants, and even work with composite records built from multiple, joined Btrieve files.

Like Btrieve, XQL offers features like multi-user support, fault tolerance, comprehensive documentation, and expert technical support. And you never pay royalties on your XQL applications.

Solve the database dilemma with XQL, the SQL that speaks your language. See your authorized Novell dealer, or call us for more information.

*Novell GmbH
Schiess-Strasse 55
4000 Düsseldorf 11
West Germany
Tel. (0211) 5973-0*

*Novell UK Ltd.
Avon House
Sweetwell Road
Bracknell
Berkshire
RG12 1HH
United Kingdom
Tel. 0344 860400*



puter has 1 megabyte of main memory, expandable to 8 megabytes, a socket for an 80287 coprocessor, and four expansion slots: one 8-bit and three 16-bit.

For mass storage, a 40-megabyte hard disk drive and a 1.2-megabyte 5 1/4-inch floppy disk drive are built in; a 3 1/2-inch floppy disk drive is available as an option. The DIN IBM AT-compatible keyboard has 102 keys, and the system comes with a 14-inch paper-white monochrome analog monitor.

The operating system is DOS 3.3.

Price: 6895 deutsche marks.

Contact: Commodore Büro-maschinen GmbH, Lyoner Strasse 38, 6000 Frankfurt/Main 71, West Germany, 49-069-66380.

Inquiry 972.

A Menu-Driven Image-Processing Language

Synoptics has added an easy-to-use menu system to its Semper 6 Plus image-processing software package. It also includes facilities to help you develop black-box applications so you can access features and facilities specific to the application through a straightforward menu interface.

Semper 6 Plus is a general-purpose, image-processing language. It gives you interactive use, immediate execution of instructions, and a full range of constructs for looping and branching. The software is portable, so you can upgrade your system as

framestore and computer technology advances, or you can have Semper 6 Plus running on more than one computer platform simultaneously.

The top-line menu-selection display uses common image-processing functions, and you select functions using a mouse-controlled pointer. If the function you select has submenus, a simple click on the mouse pops these up instantly on the screen. If, however, you wish to carry out a function not covered by the menu system or to build up a Semper program, the menu system lets you drop down into Semper 6 Plus and type in the appropriate commands.

Synoptics has also added a new set of verbs to Semper 6 Plus that let you define the size, position, color, and content of menus. You can also

define the actions of the pointing device (mouse, trackball, or keyboard) and specify the menus to activate Semper 6 Plus programs that in turn carry out any required image handling or processing.

Semper 6 Plus requires an IBM XT with 640K bytes of RAM, DOS 2.0, a hard disk drive, a floating-point coprocessor, and a framestore card. The software also runs on the Sun-3 series with a color display, the DEC MicroVAX (including GPX), and the Silicon Graphics Personal Iris.

Price: £3500 to £6900.

Contact: Synoptics Ltd., 15 The Innovation Centre, Cambridge Science Park, Milton Rd., Cambridge CB4 4BH, U.K., 44-0223-423223.

Inquiry 949.

continued

X Window System*

As the European centre of X expertise, IXI can help you exploit this important software standard

- * Documentation
- * Source Code
Latest release of X11 on 0.25" cartridge tape and IBM PC-AT format floppies 5.25"
- * Training
Includes 4 day Programmer's Workshop
- * Consultancy

Call +44 223 462131

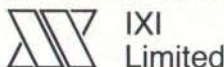

62-74 Burleigh Street, Cambridge,
CB1 1QJ, England

* X Window System is a trademark of MIT

Advertise your Computer Products in BYTE's International Advertising Section

BYTE magazine is unique in its ability to serve the needs of the Pan-European microcomputer marketplace.

For more information on advertising in BYTE, contact BYTE's London Office.

In Germany, call Roz Weyman at 0044-1-493 1451

In the U.K., call Karen Lennie at 01-493 1451

McGraw-Hill Publications
34 Dover Street
London W1X 3RA

Circle 423 on Reader Service Card

Multi-Speed V.32



A familiar feature in Nokia modems. Already proven in Nokia's ECM 4896 dial-up modem. And now incorporated in a new multi-speed V. 32/V. 22 bis modem. The ECM 9632.

The ECM 9632 provides advanced features. Full-duplex multi-speed. Trellis coding, autodialling and LAPB/MNP class 2-5 error correcting. As well as leased line operation including dial back-up.

The ECM 9632 is one of Nokia's ECM modems. Speeds from 9600 to 300 bps. Operating in applications like database, PC and mainframe communications, electronic banking, electronic mail, reservation services or videotex. All according to CCITT and de facto standards.

With the high performance and reliability you have come to expect from us.

NOKIA
DATA COMMUNICATIONS

P.O. Box 122, SF-00381 Helsinki, Finland
Phone +358 0 5671, Telex/teletex 1000627, Fax +358 0 567 3722

Circle 430 on Reader Service Card

BBS Sysops

Are you looking for ways to improve your board? Something that will set you apart from other boards in your area? Are your subscribers interested in Microcomputers? Listen to this!

Announcing the Bulletin Board EXchange

The Bulletin Board Exchange allows you to become a publisher of MicroBYTES Daily, an on-line news service from BYTE. Bulletin Board Exchange/MicroBYTES is a custom package of news and features designed especially for local BBSes, and is available only to sysops.

Every Monday through Friday you get articles about developments in microcomputing, telecommunications and selected new product announcements. Get the latest news about MS DOS machines, Macintoshes, Unix workstations, Amigas, Atari Sts, peripherals and software. All the stories are reported, written, and edited by the staff of BYTE Magazine, BYTEweek and BIX, and our world-wide network of reporters and editors.

Not only do you get a great resource for your subscribers, but you also get access to BIX which will cut your cost of exchanging information and conducting BBS network business.

All this is just \$49 a quarter.

Your one-year subscription to the Bulletin Board Exchange (billed quarterly) may be cancelled any time without further charge; just notify us. If you prefer, you may subscribe for three months only, at just \$69.

If you call BIX direct, you pay no hourly telecommunications charge. If you call using Tymnet, the rates are only \$2/hour on evenings and weekends and \$8/hour on weekdays. You may also purchase unlimited off-peak Tymnet for just \$15 a month.

Subscribe today.

BIX

One Phoenix Mill Lane
Peterborough, NH 03458
800-227-2983
In NH 603-924-7681

WHAT'S NEW

INTERNATIONAL

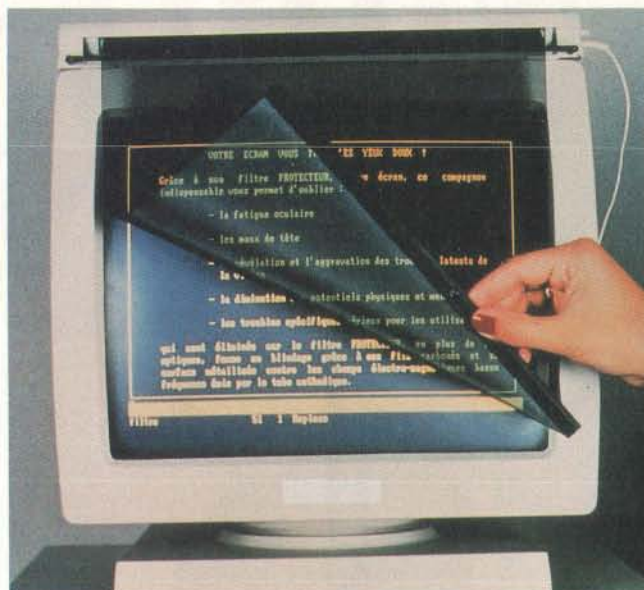

LeShield/Aquila eliminates glare and blocks electromagnetic emissions.

A Shield Against VDT Emissions

Using a video display terminal (VDT) can cause headaches, tired and watery eyes, and other eye problems. In addition, long-term exposure to the very low-frequency and extremely low-frequency radiation that the CRTs in the monitors emit may affect your health.

According to DMS, its LeShield/Aquila emissions barrier eliminates more than 85 percent of the glare, reflections, and other images that can irritate your eyes, and it also shields you against electromagnetic frequencies.

On the side that faces you, the filter has a matte black finish that increases contrast and enhances the images while reducing glare. On the side facing the monitor, LeShield/Aquila has PermaMesh bonded to it. PermaMesh is a microweave fabric with nickel, iron, copper, and chrome vapor-deposited on it. The metals form an alloy shield that blocks the magnetic and electrical emissions. Also, because LeShield/

Aquila conducts electricity, installing and grounding it eliminates the high-voltage electrostatic charges that VDTs can generate, according to the company.

You can use LeShield/Aquila with any type of monitor, and it includes a system that lets you adjust the focal distance to suit your needs.

Price: \$120 U.S.

Contact: DMS, 13, rue Louis Garneray, 06300 Nice, France, 33-93-56-04-40.

Inquiry 932.

An Auto-Router Feature for HiWire-Plus

Riva has added an auto-router to its HiWire-Plus printed-circuit-board design software (see What's New International, page 88IS-12, November 1988 BYTE). The HiWire-Plus Autorouter is a rip-up and reroute, gridless, via-minimizing, and multi-layer auto-router.

The new auto-router lets you specify track widths and spacing with a resolution of one-thousandth of an inch and

continued

TOSHIBA

THE LAPTOP LEADER QUALITY, AVAILABILITY, SUPPORT

SYSTEMS

• **T-1000**
80C88, 720 KB,
512K memory, MS DOS

\$760

• **T-1200 F**
1 MG RAM, Dual 3½"
720 KB, 80C86

\$1295

• **T-1200 FB**
1 MG RAM, Dual 3½",
720 KB, 80C86, Back Lit

\$1530

• **T-1200 H**
20 MB Hard Drive,
720 KB, 1 MG RAM,
80C86

\$2150

• **T-1200 HB**
20 MB Hard Drive,
3½" 720 KB,
1 MG RAM, Back Lit

\$2280

PRINTERS

• **311 Express Writer**

\$375

24 pin

• **P 321 SL**

\$450

216 cps. dot LQ

• **P 341 SL**

\$650

216 cps., 72 cps LQ,
wide carriage

• **P 351 SX**

\$920

360 cps., 120 cps LQ

• **PageLaser 12**

\$2327

12 pgs. per min.,
up to 25,000 pgs.
per mo.

CORPORATE DISCOUNTS AVAILABLE

- 1 YEAR WARRANTY
- AUTHORIZED TOSHIBA
SALES & SERVICE
CENTER
- EXPORT SPECIALISTS

• **T-1600 \$3199**

12 MHz, 20 MB
hard disk, 1.44 MB 3½" diskette
drive, 1MB RAM

detachable backlit EGA display

• **T-3100 \$2600**

640K RAM, 720K,
3½", 80286, 20 MB Hard Disk

• **T-3100e \$2650**

80286, 20 MB
hard disk, 20 ms, 1 meg RAM

• **T-3200 \$3450**

40 MB Hard Drive,
EGA, 1 MG RAM, 1 Drive, 80286

• **T-5100 \$4360**

40 MB Hard Drive,
1.44 Drive, 2 MB RAM, 80386

• **T-5200 \$5950**

80386, 40 MB
hard drive, 2MB RAM, 1.44 floppy,
29 ms, VGA

100 MB hard drive
25 ms, VGA

\$6950

EXTRAS

- 768K card for T 1000 . . . **\$299**
- Modem for T 1000 **299**
- Carrying case for T 1000 . . **49**
- Laptop Modems **299**
- 5¼ ext. drive **325**
- 720K floppy disk drive . . . **80**
- Carrying case for 3200
and 5100 **59**
- 1.44 floppy disk drive . . . **100**

Carrying cases, modems, and
memory boards avail. for all
systems listed above.

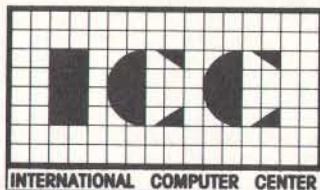

818-894-1100

FAX 818-891-3285

16175 ROSCOE BLVD. SEPULVEDA, CA 91343



assign each type of network its own design rules. It supports through-hole vias, blind vias, buried vias, and micro vias, and you can specify the size and shape of each via; sizes and shapes can vary from layer to layer.

The Autorouter can route from 1 to 250 layers simultaneously and lets you manually preroute critical circuitry so that, while the auto-router recognizes and uses the pre-placed tracks, it will not rip up or move them.

The HiWire-Plus Autorouter requires an IBM PC with 640K bytes of RAM and DOS 2.0.

Price: £695.

Contact: Riva Ltd., 3 Bentley Industrial Centre, Bentley, Farnham, Surrey GU10 5NJ, U.K., 44-0420-22666. **Inquiry 952.**



The RLC-200 transfers secure, error-free data over two-way radio.

A Radio Link Controller

A communications processor that provides an error-corrected full-duplex RS-232C data channel over a radio

transceiver is available from Communications & Measurement Technologies (CMT). Called the RLC-200 Radio Link Controller, it is the first in a range of data communications and telemetry products developed by CMT and called RADACS (for Remote Ac-

cess of Data and Control Systems).

The device uses the packet radio principle: It transmits data by breaking it up into packets or groups of characters. When it assembles a packet, it includes the address of the recipient and the error-correcting information before transmission. The transceiver checks this packet and requests retransmission if errors occur. Proprietary data encryption is supplied as standard; Data Encryption Standard (DES) encryption is available as an option.

The microprocessor-based RLC-200 provides the host computer with an RS-232C serial port through which you can communicate commands and data for radio transmission on the telemetry, private

continued

**OEM'S
WELCOME**

**EE286 B-II
BABY-AT-MOTHERBOARD**

20 MHz/0 WS



**DISTRI-
BUTORS
WANTED**

THE MOST RELIABLE DESIGN

- Highest Quality Control With German Standard
- Manufactured With Siemens-SMD-Automatic-Placement-Machine
- Under Industrial Application Tested
- Only I-Class Components
- 95% Off All Sockets From AMP
- CPU: AMD-80286-16

THE MOST FUTURE-ORIENTED DESIGN

- 80% SMD-Components
- Uses NEAT-Chips-Set from C&T
- 8/20 MHz Zero-Wait-State Operation
- Programmable Bus-Clock-Speed
- Expandable Up to 8MB On Board
- Supports EMS LIM 4.0
- OS/2 Compatible
- Xenix/Unix/Concurrent-Dos Compatible
- Interleaved Memory Allows Use Of 100ns-DRAM
- Uses SIM-DRAM-Modules
- Uses AWARD-BIOS Latest Version

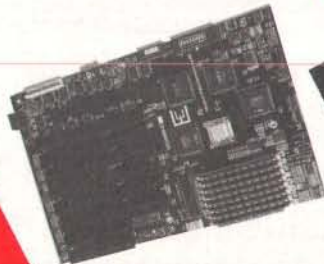

CALL US TODAY !!

Electronic Equipment
Computervertrieb
D-8060 Dachau
Ludwig-Thoma-Str. 9
Telefon (49) 81 31 / 42 72
Telefax (49) 81 31 / 8 26 67
Telex 527 503

Simply Brilliant. . .

SketchMaster™ Breaks The Power & Price Barrier



GTCO's SketchMaster uses so little power it doesn't need a power supply.
Yet, you get all the high resolution graphic, drawing, tracing and menuing capacity you need in a digitizer.

THE SECRET

SketchMaster's low power consumption. The tablet's powered directly by the serial port of the workstation computer. Power supply clutter and cable tangles are eliminated.

MOST WANTED FEATURES

Resolution of 1000 points per inch. Clear overlay protects and holds menu in place. Ergonomically designed 4 button cursor and pen-shaped stylus. Lightweight. Rugged. Wedge shaped. Two popular sizes: 12 x 12 and 12 x 18. Two color tablet matches PC color scheme.

EXCELLENT COMPATIBILITY

Designed to work with any computer and virtually all popular digitizing software.

BUILT-IN RELIABILITY

SketchMaster is backed by a five year limited warranty and fast, expert, factory service. Built in the U.S.A., the SketchMaster features advanced electronic components, state of the art technology and engineering.

LOW COST

With GTCO's SketchMaster you get a complete high performance system without paying a high performance price. To order SketchMaster call your local dealer or get in touch with GTCO today.

GTCO Corporation

A Graphics Technology Company
7125 Riverwood Drive, Columbia, Maryland 21046
Phone: 301/381-6688 Telex: 898471 Fax: 301/290-9065

Making Brilliant Ideas Better

Circle 413 on Reader Service Card

Turn your lifetime of experience into the experience of a lifetime.

We're looking for executives who know their way around the trenches as well as the front offices. Because if you're recently retired, there's a whole world out there desperately waiting to be taught what you spent a lifetime learning.

Through the International Executive Service Corps—the not-for-profit organization that sends U.S. managers to help businesses in developing nations—you can volunteer for short-term assignments in foreign countries where you're truly needed. Although you will not be paid, you and your spouse will receive all expenses, plus the personal satisfaction of teaching others while you discover more about yourself.

Think of it. Your experience can make a difference in a land much different from your own. Instead of ending your career, you could be starting the experience of a lifetime.

Send for more information today.



**International
Executive
Service Corps**

YES, I'd like to share my lifetime of experience with others. I recently retired from my position as a hands-on manager with a U.S. company. I also understand that volunteers and their spouses receive expenses, but no salary. Please send me more information now.

Name _____

Address _____

City _____ State _____ Zip _____

Write to: IESC, 8 Stamford Forum, P.O. Box 10005, Stamford, CT 06904-2005. Or, for faster response, call this number: (203) 967-6000.



A Public Service of
This Publication

EI

mobile radio, or marine band.

Each controller has a unique address so that once it establishes a connection, the RLC-200 automatically routes the data to the correct address and performs full error detection and correction.

Three versions of the RLC-200 are available: a stand-alone unit, a rack-mountable printed-circuit board on a Eurocard, or a unit for 19-inch rack mounting.

Price: £375.

Contact: Communications & Measurement Technologies Ltd., 24 Linford Forum, Rockingham Dr., Linford Wood, Milton Keynes MK 14 6LY, U.K., 44-0908-690690. **Inquiry 928.**

Combine the Capabilities of DOS and Unix

JSB MultiView DeskTop is designed to provide windowing features that combine the extensive capabilities of DOS and Unix. It provides a low-cost graphical windowing alternative for DOS-based 80286 and 80386 personal computers running Microsoft Windows (or Presentation Manager) for users who wish to gain access to Unix applications without any noticeable overhead.

You link your DOS personal computer to the Unix host via an RS-232C or LAN interface. JSB MultiView DeskTop then lets you choose from a combination of applications that reside locally under DOS or remotely on the Unix host. Once you've made your selection, you can run the DOS and Unix applications simultaneously in different Microsoft windows on your IBM PC. In this way, you retain the local DOS functionality with the added bonus of access to Unix applications on a remote system. JSB MultiView

DeskTop also lets you cut and paste and transfer files between DOS and Unix and between Unix and DOS, providing further integration of applications.

For each Unix window, you can set characteristics such as font type and size, scaling, and cursor tracking. JSB MultiView DeskTop provides emulation for DEC VT-100, VT-220, and VT-240 color terminals and lets you set the foreground and background colors for each window for all emulations. You can introduce color to monochrome applications by mapping monochrome attributes—bold, underline, and so on—to color.

Also available from JSB Computer Systems is JSB MultiView, a multitasking windowing environment only for Unix. The program provides a user-friendly window interface with desktop accessories that mirror the working environment by offering multiple active windows. It works on ASCII terminals and bit-mapped consoles in PC-style systems without graphics hardware and lets you transfer between active applications, files, and printers with cut-and-paste facilities. **Price:** £125 for JSB MultiView DeskTop; £395 to £750 for JSB MultiView.

Contact: JSB Computer Systems Ltd., Cheshire House, Castle St., Macclesfield, Cheshire SK11 6AF, U.K., 44-0625-33618. **Inquiry 927.**

Link ARCnet Networks to VMEbus Systems

Using Comprocontrol's CC-121 double-height Eurocard, you can link 2½-Mbps ARCnet token-passing networks to VMEbus systems and transfer data across

continued

MAGIC

Computer Aided Programming
Application Generator & Relational Data Base

The Story Behind dBASE
More interesting is how the respondents placed a lesser-known package, Magic PC, in the top grouping and relegated a very well-known package, Ashton-Tate's dBASE III Plus to Eighth place.

PC WEEK

no. 1

IN PROGRAMMING POWER

MAGIC BENEFITS

- ★ Reduction of 60 to 90% in software development time
- ★ Huge savings in software maintenance costs
- ★ Integral IBM™ host communication
- ★ Enhanced human engineering
- ★ Standardization in development & end-user interface
- ★ Portability between various operating systems - PC-DOS™, Unisys-BTOS™, Convergent-CTOS™

STATE-OF-THE-ART FEATURES

- ★ Automatic non-procedural processing
- ★ Quick prototyping tool
- ★ Full multi-user RDBMS
- ★ Multi-file pop-up windows and zoom techniques

OTHER MAGIC REVIEWS

- "There is no competitive product" (PC TECH JOURNAL)
 "One of the most powerful DBMS packages available" (PC MAGAZINE)
 "Excellent overall value" (PC WORLD)

DEALER ENQUIRIES WELCOME



MAGIC PC IS THE U.S. VERSION OF MAGIC

Magic Headquarters MSE Ltd. 3, Bezael St. Ramat Gan Israel 52521 Tel: 03-7511914 Fax: 03-7516218 Tlx: 371728 MASOV ■ Magic France S.A. Tel: 01-4897-4820 Fax: 01-4897-8125 ■ Magic Germany Tel: 08341-5120 Fax: 08341-41946 ■ Magic Austria Tel: 0222-53-59-860 Fax: 0222-53-59-861 ■ Australia Sigma Data Corporation Tel: 02-957-3777 Fax: 02-957-2013 ■ Japan Wacom Co. Ltd. Tel: 03-985-7901 Fax: 03-985-7934 ■ U.S.A. Aker Corp. Tel: 714-250-1718 Fax: 714-559-4966

Circle 425 on Reader Service Card

OVERALL SCORES

Four DBMS Contenders Awarded Top Honors By Respondents

- | | |
|----|---|
| 75 | Magic PC Ver. 2.5
Aker Corp.
Tied for tops in Programming Languages and Report Flexibility |
| 75 | Paradox Ver. 2.0
Borland International
Shared highest ratings in Report Flexibility and Documentation |
| 75 | FoxBase Plus Ver. 2.1
Fox Software
Awarded top honors in Support features and Performance |
| 75 | dBXL Diamond Release Ver. 1.2
WordTech Systems
Rated tops in Ease of Programmability |
| 72 | VP-Info Ver. 1.4
Paperback Software
Rated the highest in Value Relative to Cost, Installation |
| 71 | R:base for DOS
Microrim
Solid showing with above-average scores in all but one attribute |
| 70 | Advanced Revelation Ver. 1.2
Revelation Technologies
Respectable showing with six above-average scores |
| 69 | DataEase Ver. 2.53
DataEase
Solid showing; below-average score in Programming Language |
| 68 | The Smart Database Ver. 3.1
Informix Software
Below-average scores in eight features, including Performance |
| 66 | Condor 3 Ver. 2.20
Condor Computer
Tied for tops in Documentation Clarity, lowest in Reporting |
| 65 | dBASE III Plus Ver. 1.1
Ashton-Tate
Nine below-average scores; above average in Documentation |
| 64 | PC/Focus Ver. 3.0
Information Builders
Lowest in Relative Value; shared tops in Report Flexibility |
| 63 | Professional Oracle Ver. 5.1A
Oracle Corp.
Decent showing. Average scores, but lowest in Installation |
| 62 | Omnis Quartz Ver. 1.13
Blyth Software
Rated lowest in Performance. Ease of Programmability |
| 62 | DataFlex Ver. 2.3
Data Access Corp.
Bottom scores in Documentation Clarity, Vendor Support features |
| 61 | KnowledgeMan/2 Ver. 2.5
Micro Data Base Systems
Rated lowest in Power of User Interface and Ease of Use |

the VMEbus in 10 megabyte-per-second bursts.

The CC-121 is based on a SMC COM 9026 controller and has a 2K-byte high-speed (access time 100 ns) dual-ported RAM buffer that can hold up to four data packets with a maximum length of 508 bytes per message to ARCnet. Including software overheads, the company claims the throughput on the ARCnet is 1.5 Mbps.

It transfers data packets to and from star- or (optionally) bus-topology ARCnet networks using coaxial or fiber-optic cables, which you can mix within the same system. You can connect up to 255 nodes to the network with a maximum distance between nodes of 2000 feet for coaxial cable and 4000 feet for fiber-optic cable.

The VMEbus interface has a seven-level interrupt requester, with a software-programmable interrupt vector. Software drivers are available for OS-9/NET (an optional extension for networked OS-9 systems); other drivers are available on request.

Price: \$825 U.S.

Contact: Comcontrol B.V., Stratumsedijk 31, P.O. Box 193, 5600 AD Eindhoven, Holland, 31-040-124955.
Inquiry 917.

A Modem for Easier European Data Transfers

As you probably know, European modems differ depending on the country, and it is difficult to transfer

data between European countries accurately and without hassles.

To help solve this problem, Computer Peripherals has developed the Euro Hook-Up 12/24 internal modem, which complies with European PTT requirements and provides an all-in-one European modem operating at 2400, 1200, and 300 bps. You select the appropriate country using a DIP switch or through software (Hayes or CCITT Command), and the line interface becomes compatible for any country.

The Euro Hook-Up 12/24 offers a range of functions, including auto-originate, auto-answer, auto-reverse mode, and auto-dial with storage of up to 100 numbers. It requires a half-size slot in an IBM PC, XT, AT, PS/2 Model 30,

35, or 70, or compatible. Other features include analog loopback diagnostics and self-test, internal test pattern generation, a 256-character command buffer, automatic tone (DTMF) and pulse detection, automatic speed and bit-character selection, and automatic buffering. The Euro Hook-Up 12/24 comes bundled with Procomm software that runs under DOS or OS/2. You can upgrade the 1200-bps modem to the 2400-bps modem by replacing a chip.

Price: 2495 French francs for the 1200-bps modem; 3495 FF for the 2400-bps modem.

Contact: Computer Peripherals S.a.r.l., 75, avenue Parmentier, 75011 Paris, France, 33-1-43-55-30-64.
Inquiry 961.

continued

Quality In... Quality Out

No matter how well acquainted you are with making important personal computing decisions—decisions that may involve hundreds of thousands of dollars—the value of those decisions is only as good as the value of your information. Without quality information—it's hard to make quality decisions.

BYTEweek, McGraw-Hill's new weekly newsletter for professionals in the personal computer industry, is devoted to giving you that quality information through its timely and compact one-stop news format. And BYTEweek interprets this news with in-depth commentary and analysis.

Subscribe to BYTEweek for quality information. Remember, quality in... quality out.



Take advantage of the special one-year charter subscription rate of \$395 (\$495 outside the U.S. and Canada)—a savings of \$100 off the regular rate. Your subscription includes 50 issues plus a free three-month subscription to BIX—a \$49 value.

Don't miss this opportunity! In the U.S., call BYTEweek's toll-free number: **1-800-258-5485**, in N.H. and outside the U.S., call: 1-603-924-9281.

BYTEweek offers a *money-back guarantee* if you're not completely satisfied.

BYTEWEEK 

News and Analysis for Professionals in the
Personal Computing Industry
One Phoenix Mill Lane, Peterborough, NH 03458

POLYTRON Tools: Save Money, Save Time, Save Effort!

It's a wonder complex software ever works. The process of creating it is inherently error-prone. Our Configuration Management tools manage the process, enhance communication and coordination, and help ensure product reliability. In short, they save money, effort and time during every phase of the product lifecycle.

PVCS

The core of Configuration Management is version control. The POLYTRON Version Control System (PVCS) provides complete control over the configuration of source code, object code, tools and even documentation. Previous versions are easily retrieved at any time. The most up-to-date version is instantly available and its genesis is auditable. You always know who made a change, what the change was, when it was made, why it was made and what revisions contain the change. You can prevent unauthorized changes and coordinate revisions, special versions and upgrades — automatically.

PolyMake

PolyMake automatically invokes your compiler, linker and tools to rebuild your system when modules change. The multi-language dependency generator brings even more precision to builds.

Features include integration with PVCS and PolyLibrarian, hierarchical dependency trees, configurable paths, conditional constructs, nested include files, multiple OS compatibility and "list of files" support.

PolyDoc

PolyDoc automates the nastiest job in programming — Source Documentation. The alternative is manually gathering source

documentation from obsolete specifications, wads of scribbled notes and ruminations of absent-minded programmers. With PolyDoc, programmers, project leaders, teams and entire organizations have an easy, practical way to create, share and reference project documentation. PolyDoc compiles a Project Documentation Library (PDL) that stays current with the project as it evolves. Source documentation is automatically extracted from the code and other references and organized in the PDL according to keywords the programmer has embedded in the code.

PolyLibrarian

PolyLibrarian can create object code libraries with any language that produces object modules that can be linked with MS-DOS LINK, Phoenix PLINK86 or a compatible linker. PolyLibrarian is easy to use, so libraries can be optimized for specific projects or generalized for maximum functionality.

PolyLibrarian promotes supplying modules as "black boxes" for testing and integration. Teams "publish" a library consisting of their properly compiled modules, ready to be linked with other modules. This eliminates compiler switch and procedural errors and speeds building and testing since modules are precompiled.

PolyShell

PolyShell redefines MS-DOS as an environment for programmers — its UNIX-style tools and functions are designed to aid and speed the tasks that programmers do. There is no need to modify your programming tools, languages or software. A comprehensive tutorial guides users through the internal commands and all 96 utilities. Interactive help is always available.

PolyAWK

As a programmer you are confronted with manipulations of source code, data or text that fall outside the capabilities of editor macros or common tools. For these quick and dirty jobs you need a quick and dirty tool builder. AWK is a language optimized to quickly write tools. PolyAWK is a true implementation in MS-DOS or OS/2 of NAWK.

PolyAWK permits even the new user to construct elegant tools in a few lines of code — written, debugged and working in minutes. Inherent structure and excellent string handling is the secret to AWK's concise nature and remarkable readability. When you order PolyAWK you receive a copy of "The AWK Programming Language" by Aho, Weinberger and Kernighan.

Pricing

POLYTRON products can be used independently or together, and are priced on a "Per User" basis. The price per user decreases as you add users — call for quotes. Personal PVCS for MS-DOS or Mac MPW: £85. Professional PVCS: £225. Network PVCS: Call. PolyMake for MS-DOS: £85. Network PolyMake: Call. PVCS & PolyMake are packaged together on: OS/2, SunOS, VAX/VMS, IBM AIX. Call for pricing. PolyDoc for MS-DOS: £115. PolyLibrarian for MS-DOS: £85. PolyShell for MS-DOS: £60. PolyAWK for MS-DOS: £60. PolyAWK for OS/2: £115. PolyAWK + PolyShell Combination (Save £35): £85.

To Order, Call
(0763) 73455
FAX (0763) 73460

The Software Construction Co., Ltd.
The Red House, 84 High Street,
Buntingford, Hertfordshire SG9 9DJ

POLYTRON

High Quality Software Since 1982

Upcoming International Events

C Programming Hands-on Workshop

Integrated Computer Systems (ICS) will present C-Programming Hands-on Workshops on the following dates: July 25-28, September 5-8, and October 17-20.

The program agenda will include Starting C; Fundamentals of C Programs; Arrays, Structures, and Pointers; Modular Programming and Libraries; Systems Programming Techniques; Software Tools for C Programming; and C Implementations.

The workshop will teach you to write new programs in C, figure out and maintain large C programs, and maximize portability without loss

of efficiency, according to ICS.

Price: £795.

Contact: ICS Publishing Co. (U.K.) Ltd., ICS Education Centre, Trafalgar House, Hammersmith International Centre, London W6 8DN, U.K., 44-01-748-6667.

Inquiry 941.

MacWorld Expo Asia '89

The first MacWorld Expo in Asia will be held June 29 to July 2 at the Raffles City Convention Center in Singapore.

Contact: MacWorld Expo Asia '89, 39 Sixth Ave., Level 2, Mulpha Building, Singapore 1027, 65-468-3888.

Inquiry 940.

Euromicro '89

This fifteenth symposium on microprocessing and microprogramming will be held on September 4-8 in Cologne, Italy.

The purpose of the symposium is to bring together people from business, industry, government, and education who are interested in problems related to the underlying technology and use of microcomputer systems.

This year's theme is "Design Tools for the 90s," and authors are invited to submit original papers on recent applications, developments, and research.

Contact: Euromicro '89, Attn.: Mrs. Chiquita Snippe-Marlisa, P.O. Box 545, 7500

AM Enschede, The Netherlands, 31-53-338799. Inquiry 943.

Comdex/Asia Pacific '89

Comdex/Asia Pacific '89 is slated for August 1-3 at Darling Harbour Convention Center in Sydney, Australia.

Participants from Australia and New Zealand, the Indian subcontinent, the People's Republic of China, Singapore, Indonesia, the Phillipines, Taiwan, and Korea are expected.

Contact: The Interface Group, Inc., 8 West St., North Sydney, NSW 2060, Australia, 61-02-959-5555. Inquiry 942.

B Y T E B A C K I S S U E S F O R S A L E

	1987	1988	1989
January			
February			
March			
April			
May			
June			
July			
August			
September			
October			
November			
December			
Inside the IBM PCs			

Issues Available

Rates (postage and handling included):

Holland	Dfl 18.00	Switzerland	SwFr 13.50
United Kingdom	£ 5.25	France	FFr 54.50
West Germany	DM 16.50	Sweden	SEK 56.50

No other currencies will be accepted other than those mentioned above.

Please indicate which issues you would like by checking (✓) the boxes. Send requests with payment to:

BYTE Back Issues, c/o Dynamic Graphics International, P.O. Box 25, 3950 AA Maarn, The Netherlands

Check enclosed

Charge: MasterCard Eurocard American Express

Card # _____

Exp. Date _____

Signature _____

Name _____

Address _____

Postcode _____ City _____

Country _____

All orders must be prepaid. Pay only in currencies given. Please allow twelve weeks for delivery by surface mail.

The user-friendly,
multi-system,
easy-fitting,
tried 'n' tested,
fully-featured,
fast & flexible
open network system.



... so why doesn't it cost more?

Even as we speak, your Network may be about to be invaded by hordes of Macs, SUN workstations et al., as your users realise that the world is no longer a totally Blue or exclusively DOS oyster.

You have three choices.

Change your job... plunge into the appalling intricacies and expense of trying to get your current LAN to accept these newcomers... or investigate TOPS.

TOPS is an open system, distributed, a completely transparent approach to Local Area Networking that was originally adopted by SUN itself because it reflects their basic philosophy of total flexibility and Open Computing.

It has also become the 3rd most-installed network system worldwide.

TOPS cheerfully accepts DOS, Mac & SUN UNIX machines in any mix or proportion; doesn't need a central file server;

can be installed in minutes; lets each user go on using their own machine's familiar interface; is fully NetBIOS compatible... and so on, and so on.

Want gateways to your mainframe or other networks? No problem.

Want to keep adding more peripherals, more users, more bells & whistles?

A doddle.

TOPS. It's what networking will be when everyone else catches up.

TOPS from SUN
TEL 0276 62111



SUN
microsystems

TOPS division

TOPS. Rush me details.

Name _____
Job Title _____
Company _____
Address _____
Tel. _____

TOPS[®]
Now we're talking



Tops Division, Sun Microsystems, Sun House, 31-41 Pembroke Broadway, Camberley, Surrey. GU15 3XD. All trademarks acknowledged

I'm an existing TOPS user. Please send me upgrade details.

BYTE 6



Writing Macintosh Device Drivers

Joel West and Mark Anderson

With open Macs, a thorough knowledge of device drivers is no longer a curiosity—it's a necessity

When the Macintosh was first introduced, you didn't have to worry about device drivers: Apple had already written the low-level drivers for the serial ports, mouse, keyboard, and floppy disk. The built-in display was managed by QuickDraw calls that wrote to the screen's memory-mapped video buffer. The Mac's closed architecture meant that you could not add peripheral boards to the system; no peripheral boards meant no drivers. You could write a desk accessory, which is quite similar in layout to a driver, but the limits of a total of 16 of them in a system file and an 8K-byte maximum size made this a daunting prospect.

How times have changed. Both the Mac SE and the Mac II are open systems with slots that let you expand their capabilities with any number of plug-in boards, and each board requires driver software so the Mac can make use of it. The most familiar example of this is the Mac II video board: Its configuration ROM must supply a device driver to the system to manage all transactions between Color QuickDraw and the board's hardware.

One thing is certain: The open architecture of this new generation of machines means that a thorough knowledge of how a Mac device driver works is no longer a curiosity, but a necessity.

Unfortunately, by their very nature, device drivers defy general solutions. The device that you wish to control has specific characteristics that make it unique, and those characteristics make your driver different from any other driver. But in writing a driver for a Macintosh peripheral, you're not totally on your own. There are some basic rules and guidelines for approaching the project.

Basic Concepts

Drivers are normally stored in the System file as named resources of type `DRVr`. The usual way of finding the driver is via its resource name, which is

the same as the name of the driver.

This is the same format that desk accessories use, and, in fact, the two seemingly unrelated code types share a common structure, resource type, and entries in the same system-wide table. However, a driver's name always begins with a period (e.g., `.Sony`), while a desk accessory's name begins with a null character (e.g., `\0Chooser`). The resource ID for a driver should be a small positive number, generally from 0 to 63. The entries from 0 to 39 are reserved for desk accessories and fixed, Apple-defined drivers (see "Device Manager" in *Inside Macintosh*, volume IV).

Each type of driver is accessed in a slightly different way. Ultimately, most calls go through the seven Device Manager traps listed in table 1.

On the original Macintosh, the serial, sound, and disk drivers are standard drivers; the Printing Manager and AppleTalk also use the driver interface internally. The SCSI Manager calls disk-specific drivers conforming to the standard driver format. This is also true for the Slot Manager of the Mac II, which uses the driver interface to call the video driver.

To a greater or lesser degree, if you write applications, you are insulated

from dealing directly with any driver. The File Manager handles most disk I/O and makes its own floppy and hard disk driver calls. The serial driver provides "glue" routines corresponding to the most common calls, like `SerReset()` and `SerHShake()`. For printer drivers, the only call used implicitly is the control call, which occurs in response to a glue routine called `PrCtlCall()` (recently replaced by a trap of the same name).

Where They're At

For a driver to be accessible to the Macintosh operating system, it must be installed in the *unit table*, which is an array of handles to descriptions of each installed driver. This group includes those drivers that are currently open or, in unusual cases, drivers that have been manually installed in the unit table. The table is shared by both drivers and desk accessories.

As indicated in figure 1, a pointer to the unit table is stored in the system global variable `UtblBase` (at location `0x11C`). On the original Mac, the table is 32 entries long; on the Mac Plus and SE, it's 48 and 64 entries long, respectively. On the Mac II, the unit table starts with 64 entries, but if that's not enough, the Slot Manager increases it to 128. The actual length of the table is stored in global variable `UnitNtry` (at location `0x1D2`).

For each driver, the unit table contains a handle that references a device-control entry (DCE). The ROM trap `_DRVrInstall` allocates 40 bytes for this data structure on a Mac Plus, 50 bytes on a Mac SE, and 52 bytes on the Mac II. In the Mac II, the DCE was extended to include Slot Manager information for each driver; in the Mac SE, the inclusion of all but one of these new fields is inexplicable, since, from a driver standpoint, the Mac SE is essentially the same as the Mac Plus.

The DCE contains basic information about the device driver, including a

continued

queue of pending I/O operations, the driver reference number, and a handle to the driver's private data storage. The DCE also contains a reference to the actual driver; a flag bit indicates whether this reference is a pointer or a handle (Apple's ROM drivers use pointers).

How to Call a Driver

When an application opens a driver, the Device Manager first looks for it among the installed drivers in the unit table, using the name stored in the driver's header. If it doesn't find the driver installed, it looks for DRVr resources in any open resource file.

Once a driver is found, the Device Manager installs it in the unit-table entry that is the one's complement of the resource ID. This means that DRVr -41 would be installed in unit-table entry 40. `_Open` or `OpenDriver()` returns the -41 that the application uses to reference the open driver in all subsequent calls.

Some programmers think the `OpenDriver` call that most applications use opens the device drivers. It doesn't; it calls `_Open`. In fact, the File Manager's

`FSOpen` and `OpenDriver` both call `_Open` to do all the work, even though `FSOpen` has different parameters and fills out different fields in the parameter block.

How does the system tell drivers and files apart? If the first character of the name is a null or a period, `_Open` looks for a driver. If it doesn't find a driver by that name, or if the first character is something else, `_Open` tries to open a file.

Suppose you want to install a device driver that's not in a resource. First, you allocate nonpurgeable space for the driver in the system heap. Then you allocate a relocatable DCE in the system heap and zero it out. Scan the unit table for an empty slot, and install the handle to the DCE. Finally, you fill out the `dCtlDriver` (with the driver's handle) and `dCtlFlags` (from `drvFlags`) and set `dCtlRefNum` to the one's complement of the unit number.

Internal Details

The DCE contains a reference to the first byte of a driver as either a pointer or a handle. If the RAM-based bit in `dCtl-`

`Flags` is set, `dCtlDriver` is a handle, and the driver is automatically locked when it's opened and unlocked when it's closed. Normally, driver resources are defined as unlocked and purgeable.

The driver consists of a fixed-format header followed by the executable code required for the driver. In addition to the name of the driver, the header contains information about how the driver is used. MPW programmers should link the driver code with `{Libraries}DRVRruntime.o` into a DRVW resource and then merge it with the header using Rez source (see listing 1).

The driver's header includes offsets to the five standard entry points: `DRVrOpen`, `DRVrClose`, `DRVrControl`, `DRVrStatus`, and `DRVrPrime`. In MPW, these are resolved by Rez, the linker, and `DRVRruntime.o`. Each of these entry points is called with a pointer to the application's parameter block in register A0 and the DCE pointer in A1. In MPW C, the glue expects the following calling sequence:

```
pascal short DRVrControl(pb, dCtl)
    CntrlParam *pb;
    DCtlPtr dCtl;
```

As you can see in table 1, both `_Read` and `_Write` traps go through the `DRVrPrime` entry point. The `_KillIO` trap calls `DRVrControl`, but it involves special processing by both the Device Manager and the driver. Although you can open and close all drivers, some may ignore `_Read`, `_Write`, `_Status`, or `_Control` calls, as indicated in the header. In this case, you should supply a do-nothing dummy routine to satisfy the linker.

All entry points return a status value *continued*

Table 1: Device Manager calls and the corresponding driver entry points. Although the access may vary, most calls go through these seven traps.

High-level	Low-level	Trap	Entry point
OpenDriver	PBOpen	_Open	DRVrOpen
CloseDriver	PBClose	_Close	DRVrClose
FSRead	PBRead	_Read	DRVrPrime
FSWrite	PBWrite	_Write	DRVrPrime
Control	PBControl	_Control	DRVrControl
Status	PBStatus	_Status	DRVrStatus
KillIO	PBKillIO	_KillIO	DRVrControl

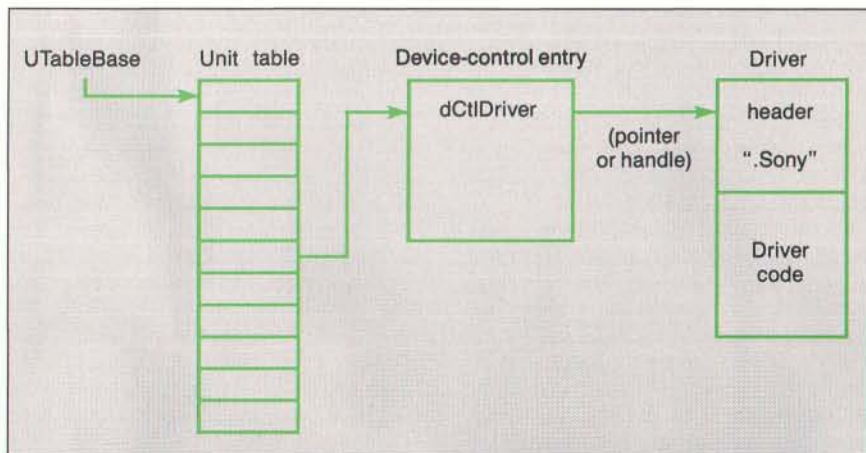

Figure 1: Finding a driver. UTableBase points to the unit table that contains handles to device-control entries. The DCE references the actual driver.

Listing 1: MPW code to define driver resources.

```
resource 'DRVr' (-8192,
    ".XPrint", purgeable)
{
    dontNeedLock,
    dontNeedTime,
    dontNeedGoodbye,
    statusEnable,
    ctlEnable,
    noWriteEnable,
    noReadEnable,
    0, /* no periodic delay */
    0, /* no events */
    0, /* no menu */
    ".Print",
    $$resource ("Driver.DRVW",
        'DRVW', 0)
};
```

INTERNATIONAL
VERSION

A



Z

~~172~~
103 different ways

When Pacific Data Products introduced *25 Cartridges in One!* we knew we had a winner! With 103 fonts and symbol sets in a single cartridge, it is the perfect font solution.

But then we asked "Why stop here?" The new international version of *25 Cartridges in One!* offers the original 103 fonts plus 69 international fonts for European business needs. It contains punctuation and currency symbols for 10 different European languages and the complete Roman 8 extended symbol set.

25 Cartridges in One! has a font for each of your business applications. There are characters for legal, technical and scientific writing, tax

forms and presentation graphics. With Pacific Data's own 4.8 pt. AFS typeface, you can print full Lotus and Excel worksheets in both portrait and landscape.

And, *25 Cartridges in One!* is ideal in remote and shared printer environments.

Get the polished look of typeset documents with *25 Cartridges in One!* Domestic or international, it is the perfect single cartridge solution for your laser printer.



PACIFIC
DATA PRODUCTS

6404 Nancy Ridge Drive, San Diego, California 92121
Tel: (619) 552-0880, Fax: (619) 552-0889

Pacific Data Euro, Ltd., Europe
Tel: (44-0734) 391222, Fax: (44-0734) 393871

Mitsui Computer Ltd., Australia
Tel: 61 02 452 0452, Fax: 61 02 452 0481

Pacific Technology, Singapore
Tel: 2615609, 2654888, Fax: 2640371

AFS and 25 Cartridges in One! are unregistered trademarks of Pacific Data Products. Lotus is a registered trademark of Lotus Development Corporation. Excel is a registered trademark of Microsoft Corporation

Circle 432 on Reader Service Card (DEALERS: 433)

JUNE 1989 • B Y T E 96IS-55

A		0			
"A" trap code	Synchronous	0	__Open	0	
	Immediate	2	__Close	1	
	Asynchronous	4	__Read	2	
			__Write	3	
			__Control	4	
			__Status	5	
			__KillIO	6	

Figure 2: Device Manager trap word. Notice the seven possible traps and the three ways—synchronous (normal), immediate, or asynchronous—in which each can occur.

synchronously and they always return normally.

If a `DRVPrime`, `DRVControl`, or `DRVStatus` entry point has been called via a synchronous request, your driver should usually jump to the `IODone` routine, as pointed to by low-memory global `JIODone` (at location `0x8FC`). It's up to your driver to determine how it was called, normally by checking the trap word stored in `pb->ioTrap`. The `IODone` routine removes this request from the I/O queue, executes the application-supplied completion routine (if any), and calls the driver to execute the next I/O request.

It's possible that the completion routine could start another I/O request, thus causing the size of the stack to grow. To avoid this problem, you should write each driver entry point in assembly language to jump directly to `IODone` with its return address on the stack. (You can also call `IODone` as a subroutine, via glue.)

The MPW 2.0 `DRVRuntime.o` glue tries to handle this problem for the driver writer by automatically providing an `IODone` call for all `DRVPrime` calls. Unfortunately, it doesn't provide the `IODone` calls required for control or status calls. Also, asynchronous read and write calls can't call `IODone` before the I/O is complete.

In actual practice, few `DRVPrime` routines actually call `IODone`. If the driver is performing direct I/O via 68000 memory-mapped locations, it will transfer the first data byte and then return. It's up to the driver interrupt routine to transfer any additional data or to call `IODone` if no more data is left.

Note that the `DRVControl` routine must treat any `_KillIO` trap (indicated by `pb->csCode==1`) as immediate. It should clean up its internal state, but it doesn't have to empty the queue or abort the completion routines—the Device Manager handles these. Figure 3 contains a flowchart illustrating the general algorithms for the control and status entry points, while figure 4 shows the `DRVPrime` and driver-supplied interrupt routines.

A Test Drive

Let's take a functional skeleton driver, `.Shadow`, as an example. The driver is written primarily in MPW C, with some assembly language code and `Rez` resource definitions. [Editor's note: *The source code listing for the program .Shadow is available in a variety of formats. See page 3 for further details.*] The `.Shadow` driver sits between any applica-

continued

Listing 2: The "glue" needed to support an immediate call.

```

; pascal OSErr PBStatusImmed
      (ParamBlkPtr pb);
PBStatusImmed PROC EXPORT
    MOVEA.L (A7)+,A1
    MOVEA.L (A7)+,AO
    _Status IMMED
    MOVE.W DO, (A7)
    JMP (A1)

```

as a function result. The `DRVRuntime.o` glue places this value in `DO`, but `DRVOpen` must place the return value in `pb->ioResult` instead, because the Device Manager clobbers the return code in `DO`.

Most device drivers require internal storage to maintain information about the device and any I/O that's in progress. The `dCtlStorage` field is used to store a handle allocated by `DRVOpen` and deallocated by `DRVClose`. A driver designed to run in the application heap should set `dNeedGoodbye` to clean up on termination; the Device Manager calls `DRVControl` with `csCode = -1` before quitting the application and wiping out the heap.

Three Kinds of Traps

Each of the seven basic Device Manager traps can be made in one of three ways, distinguished by bits in the trap word, as shown in figure 2. Two of these ways—*synchronous* and *asynchronous*—go through the I/O queue, while the third, *immediate*, does not. The default and most common case is for an application to use a synchronous call. The Device Manager waits for the driver to set `ioResult` to `noErr` or to a negative value.

However, an application may not wish to wait until a driver call (usually a `_Read` or `_Write`) is completed. Each of the low-level Device Manager calls can

be made asynchronously, either by passing *true* for the `async` parameter to `PBRead` or `PBWrite`, or by setting the asynchronous bit on the assembly language trap. The application must pass the address of its completion routine in the parameter block. This routine has to preserve registers `A2` through `A6` and `D3` through `D7` if it uses them, and it cannot call the Memory Manager, either directly or indirectly.

Normally, the Device Manager handles an I/O request by placing the application's parameter block into the operating-system queue referenced by `dce->dCtlQHdr`. As the driver satisfies a request, the Device Manager removes it and calls the driver with the next request. Any `_KillIO` call completely empties the queue; it also sets the `pb->ioResult` field to `abortErr` and then calls the application-specified completion routine.

In some cases, you may wish to bypass this queuing mechanism and let an application perform an operation directly. For example, if your application wants to find out the status of a pending I/O request, it should probably use an immediate `_Status` call. Since the standard Device Manager glue doesn't support immediate calls, you need to write your own glue (see listing 2). (Note that the Device Manager always treats the `_KillIO` trap as immediate.)

Asynchronous calls are primarily intended for `DRVPrime`, and immediate calls for `DRVControl` and `DRVStatus`. The two are mutually exclusive—that is, immediate calls are never asynchronous—and neither type of call is valid for `DRVOpen` or `DRVClose`.

IODone

When a driver responds to a trap, it may need to perform some standard house-keeping tasks before returning. `DRVOpen` and `DRVClose` routines are the simplest, since they are always called

SIEMENS

Good connections have launched many a career

The African elephant
(*Loxodonta africana*) lives in
herds led by an experienced
female. It uses its trunk like
a hand.

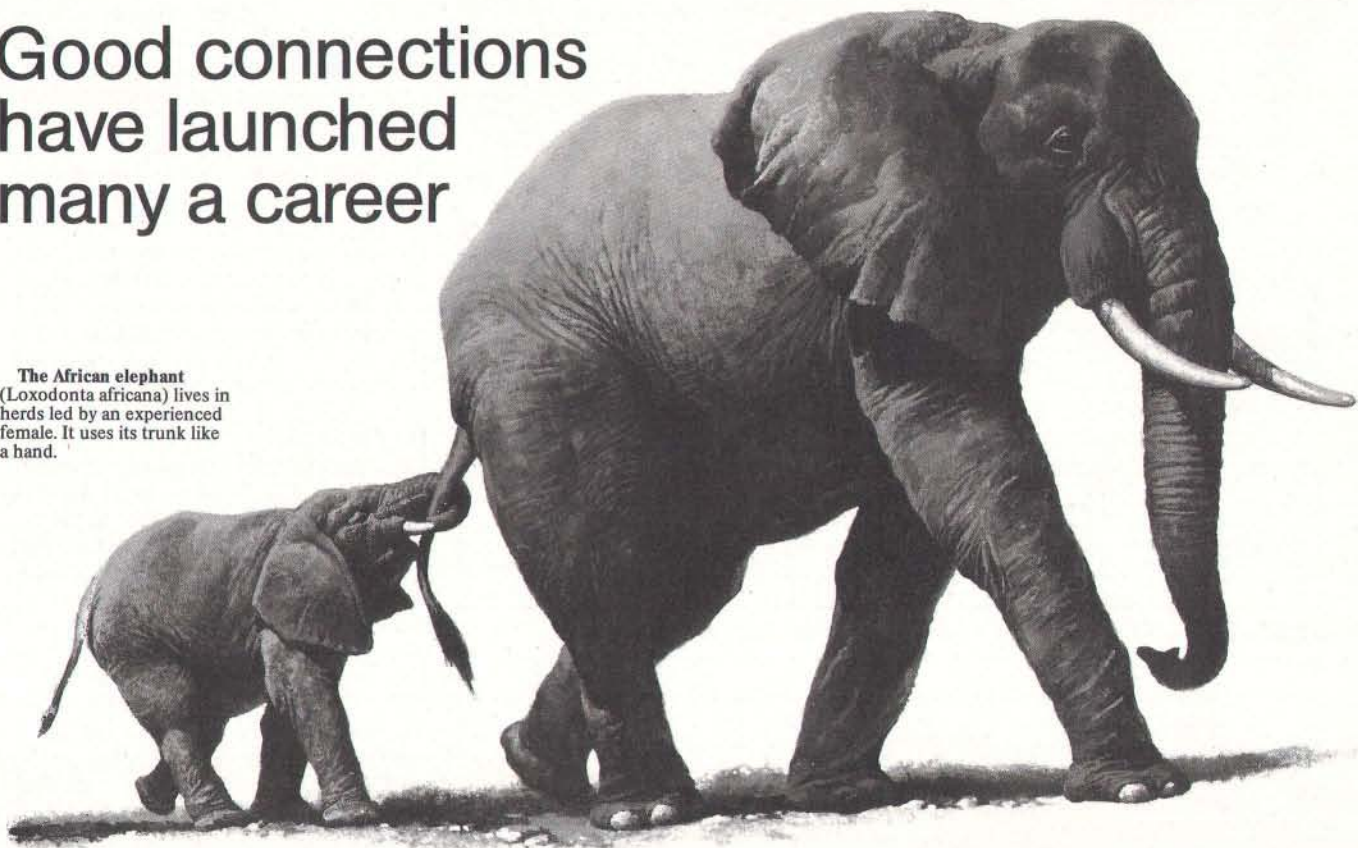

If you want to make it big, you have to pick big brains. They can offer things smaller minds can't. And not just in the animal kingdom. In the office too. It's the flow of information that keeps people and business growing. We've therefore made it possible

The Siemens PC-Concept.

to turn all Siemens PCs into main-frame terminals. Even when the host is not a Siemens computer. The solution is ComfoLink. ComfoLink can also connect an entire PC network to the host. What's more, ComfoLink can join

a network to a higher-ranking one, which in turn is connected to the host. Each aspect of the Siemens PC-concept guarantees flexible communication, reliability into the future and simplicity of operation. Siemens is, after all, the largest European manufacturer of communications and data systems and has extensive know-how in system integration. Siemens PCs are available in Austria, Belgium, France, Germany, Italy, Luxembourg, Netherlands, Portugal, Spain, Sweden and Switzerland.

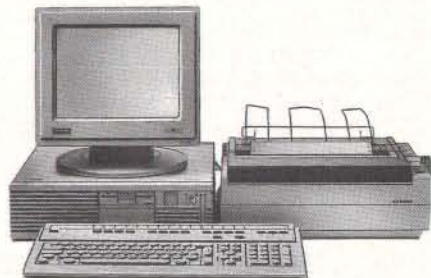

**Get it right from the start.
The Siemens PCs.**

Coupon:-----

Siemens AG,
Infoservice 131/Z035
Postfach 23 48, 8510 Fuerth, West Germany

Please send me information on the following:

Siemens PCs

Siemens printers for PCs

Name: _____

Company: _____

Full Address: _____

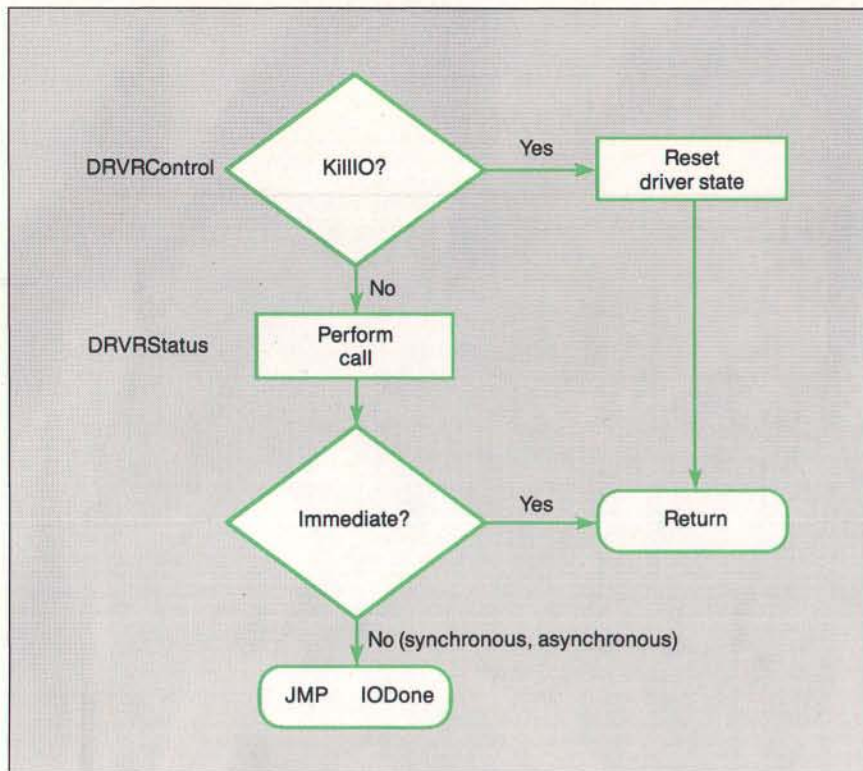

Figure 3: Flowchart illustrating control- and status-completion logic.

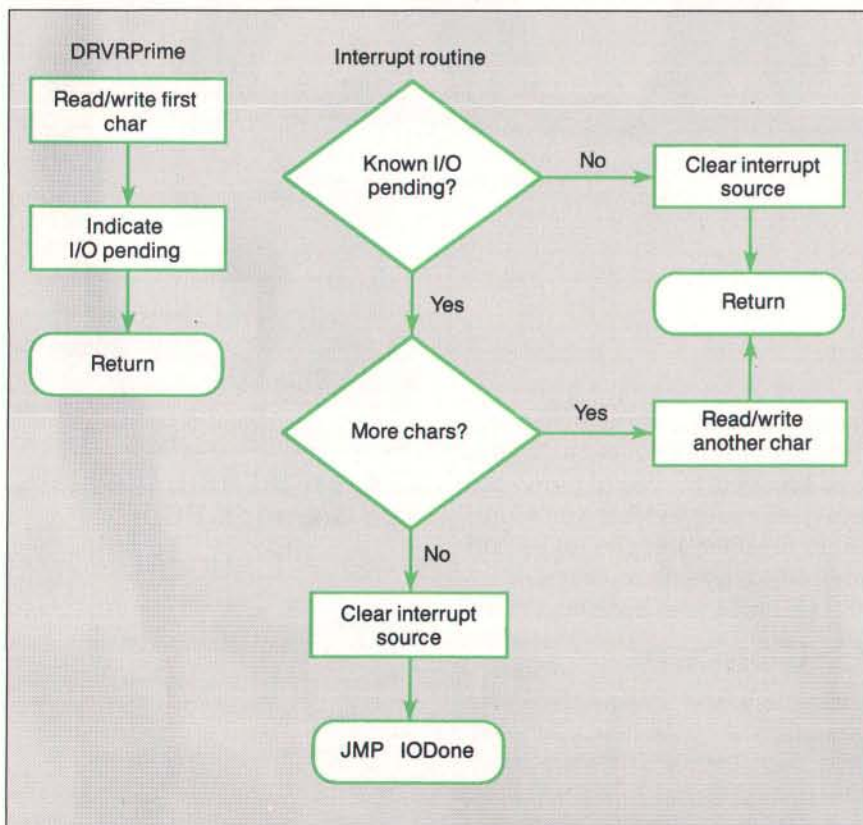

Figure 4: Flowchart illustrating read- and write-completion logic.

tion and the real driver, functioning much like a software breakout box. You could use this skeleton to log the calls to an arbitrary driver by adding code to write debugging traces to a reserved block of memory, to a serial port, or even to disk. As configured, .Shadow receives the calls for modem port .AOut and then passes them to the real .AOut driver.

.Shadow contains the five standard entry points DRVROpen, DRVRClose, DRVRCtrl, DRVRSatus, and DRVRSatus. The general strategy is to receive a parameter block from an application, patch the appropriate fields of that block, call the real driver, restore the parameter block, and return. The task is complicated by the various ways—synchronous, asynchronous, and immediate—in which you may call a driver routine, and by the completion mechanism of each.

How It Works

Let's start with the simplest case: immediate calls. The .Shadow driver replaces our driver's reference number in the parameter block with the reference number of the real driver. The same call is made to the real driver with our modified parameter block. Our driver then passes along the return value to our calling routine and restores the reference number.

For a synchronous call, our driver can use essentially the same method that it used for the immediate call: Install the real reference number, call the real driver, and then restore our driver's reference number. Instead of returning, however, the entry point calls the IODone routine to terminate the request to .Shadow.

For an asynchronous call, we must also call the IODone routine when the request is complete. In addition, the application may have specified an ioCompletion routine.

The problem with asynchronous calls lies in determining when we can safely call the IODone routine. We can't simply call the real driver's entry point and then call the IODone function when it returns; this would prematurely call the application's ioCompletion routine.

Instead of patching our parameter block, we have to allocate a new one and fill in the appropriate fields. We must specify our own completion routine that calls the IODone function at the correct time. Our ioCompletion routine also has to copy the returned parameters back into our original parameter block and free the allocated memory.

The task is further complicated because we can't call the Memory Manager

continued

80386 32-bit processor, 20MHz clock,
1MB RAM (up to 8MB on mainboard),
5.25" 1.2MB floppy drive, 1 parallel 2 serial ports,
5 free slots, size: 17.5"(D) x 6.5"(H) x 21.5"(W).

MONOCHROME HARD DISK VGA COLOUR

£1695 44MB/25mS £1995

£2395 150MB/20mS £2695

£2695 320MB/19mS £2995

286S-120

80286 processor, 12MHz clock, 640K RAM,
5.25" 1.2MB floppy drive, 1 parallel 2 serial ports,
5 free slots, size: 17.5"(D) x 6.5"(H) x 21.5"(W).

MONOCHROME HARD DISK VGA COLOUR

£1145 40MB/40mS £1445

£1345 72MB/25mS £1645

£1945 150MB/19mS £2245

286C-120 COMPACT

80286 processor, 12MHz clock, 640K RAM,
5.25" 1.2MB floppy drive, 1 parallel 2 serial ports,
4 free slots, size: 16.4"(D) x 6"(H) x 15.1"(W).

MONOCHROME HARD DISK VGA COLOUR

£995 20MB/65mS £1295

£1095 40MB/40mS £1395

£1295 72MB/25mS £1595

286M-100 SLIMLINE

80286 processor, 10MHz clock, 640K RAM,
5.25" 1.2MB floppy drive, 1 parallel 2 serial ports,
3 free slots, size: 15.8"(D) x 4"(H) x 16"(W).

MONOCHROME HARD DISK VGA COLOUR

£895 20MB/65mS £1195

£995 40MB/40mS £1295

386C COMPACT

V20 processor, 10MHz clock, 640K RAM,
5.25" 360K floppy drive, 1 parallel 1 serial port,
2 free slots, size: 15.3"(D) x 5.5"(H) x 14.5"(W).

MONOCHROME HARD DISK VGA COLOUR

£695 20MB/65mS £995

£795 40MB/40mS £1095

Each PC comes ready to use, and includes a 14" monitor, 102-key keyboard, Microsoft compatible serial mouse, MS-DOS 3.3, GW Basic, GEM/3 (1st Word Plus, Paint), full set of manuals, and a 12-month Warranty. Hard disks are shown with their average access times, in milliseconds.

3.5" 720K/1.44MB floppy drives can be used instead of, or in addition to, 5.25" variety.

Monochrome option includes a Hercules-type card and a choice of green, amber, or paper-white monitor.

VGA option runs EGA colour and Hercules monochrome.

MS-DOS, GW Basic, GEM, Hercules, and IBM are registered trademarks.

All prices are exclusive of carriage and VAT.

Elonex reserves the right to change prices and specifications without notice.

LONDON OFFICE

Elonex plc, Rays House, North Circular Road,
London NW10 7XB. Telex 94017759 ELNX G.

Fax 01-965 3246

Tel 01-965 3225

NORTHERN OFFICE

Elonex plc, 7-9 Campus Road, Bradford Science
Park, Bradford, West Yorkshire BD7 1HR.

Fax (0274) 307294

Tel (0274) 307226

Please send me information about the Elonex
product range and services C17

NAME _____

POSITION _____

COMPANY NAME _____

ADDRESS _____

TELEPHONE _____



M O D E R N A R T

Meet the 286M, a modern classic
that maintains our tradition of
providing quality and performance
at an astonishingly low price.

With an enviable standard of service
and technical support, we are justly
proud of our regular customers that
include large corporations and
public and educational bodies.

You too can join them and get into
the winning frame.

ELONEX

from inside a completion routine, since such a call during interrupt processing could confuse either the Memory Manager or the application. To avoid using the memory management routines within our completion routine, our driver maintains a list of previously allocated blocks. The driver's `ioCompletion` routine places the block back on our list of unused blocks.

When an asynchronous call needs a new block, it checks the list of free blocks. If the list is not empty, an old block is reused. If the list is empty, a new block is allocated from the system, but not until it's safe to use the Memory Manager. When the driver terminates, all the free blocks are returned to the Memory Manager.

What to Call and When

You always call open routines synchronously and complete them with a return call. Our `DRVROpen` routine patches the name of the real driver into the `ioNamePtr` field of the parameter block (`.AOut` in `.Shadow`). If the open is successful, we allocate memory in the system heap. Then we store the reference number of the real driver in this memory and initialize our list of free blocks to zero.

Like opens, you also call close routines synchronously and complete them with a return call. Our `DRVRClose` routine first calls our routine `ReturnMemory`, which disposes of each block on our list of used blocks. Then we call `CloseDriver` with the reference number of the real driver and return its return value as our own.

You can call the `DRVPrime`, `DRVControl`, and `DRVStatus` entry points as synchronous (queued), asynchronous (queued), or immediate (nonqueued). The `ioTrap` field of the parameter block determines the calling method: If bit 9 is set, it signifies an asynchronous call; if

The author of a device driver meets programming obstacles that are different, if not more difficult, than those facing the application programmer.

bit 10 is set, it signifies an immediate call. After determining the calling method, we proceed as above.

A call to `DRVControl` of `csCode=1`, representing `_KillIO`, is a special case. We have to call `_KillIO` on the real driver instead of just passing along the `_Control` call. Otherwise, the real driver's I/O queue will not be cleaned up properly.

The Challenge

In addition to device dependencies, the author of a device driver encounters programming obstacles that are different, if not more difficult, than those facing the application programmer. Debugging a program that runs at interrupt level is inherently difficult. Nonrepeatable timing errors, interactions with debuggers in interrupt routines, and differences in interrupt levels between different Macintosh models make it more difficult to find the problem. Many standard debugging techniques, such as writing information to a status window, are simply unavailable.

Each Macintosh device driver is unique, and the problems that you will encounter are different from those you may be used to. But these rules and guidelines should help you get started writing device drivers. ■

BIBLIOGRAPHY

- Designing Cards and Drivers for the Macintosh II and Macintosh SE.* Reading, MA: Addison-Wesley, 1987.
- "Device Manager," *Inside Macintosh*, vols. II (1985), IV (1986), and V (1987). Reading, MA: Addison-Wesley.

Joel West is president of Palomar Software, Inc., in Oceanside, California, and author of *Programming with Macintosh Programmer's Workshop* (Bantam, 1987). Mark Anderson is a software engineer for Palomar Software and wrote the device drivers for *Tara Four+One*, a Mac II communications board. They can be reached on BIX c/o "editors."

SUBSCRIPTION PROBLEMS?

If you have a problem with your BYTE subscription, write us with the details. We'll do our best to set it right. But we must have the name, address, and zip of the subscription (new and old address, if it's a change of address). If the problem involves a payment, be sure to include copies of the credit card statement, or front and back of cancelled checks. Include a "business hours" phone number if possible.



We want to help!

BYTE MAGAZINE
 ATTN: SUBSCRIBER SERVICE
 P.O. Box 555
 HIGHTSTOWN, NJ 08520

A new version of Turbo C with source level debugger is now available. The new Avocet C is aimed at embedded systems programmers. Prospero's C for the Atari offers excellent runtime error checking.

C COMPILERS

Advantage C++	MS-DOS	£395
Avocet C	PC-DOS	£185
Aztec C86 Professional	MS-DOS	£110
Aztec C86 Developer	MS-DOS	£165
Aztec C86 Commercial	MS-DOS	£250
CI C86 Plus	MS-DOS	£290
CI Optimizing C86	MS-DOS	£210
De Smet C Programmer	MS-DOS	£ 95
De Smet C Professional	MS-DOS	£165
ECO-C88 V4.0	MS-DOS	£ 70
HIGH C (Metaware) v1.4	MS-DOS	£380
HIGH C 386 v1.4	MS-DOS	£570
Hi-Tech C	MS-DOS	£115
Lattice C v3.4	OS/2&MS-DOS	£245
Mark Williams LETS C v4	MS-DOS	£ 60
Microsoft C v5.1	OS/2&PC-DOS	£250
Microsoft Quick C v2	PC-DOS	£ 60
MIX C	MS-DOS	£ 20
MIX Power C & lib s'ce	PC-DOS	£ 29
Turbo C v2	PC-DOS	£ 79
Toolworks C v3.2	MS-DOS	£ 40
Watcom Express C	PC-DOS	£ 65
Watcom v7 opt comp + t1sPC-DOS		£250
Zortech C v3	PC-DOS	£ 45
Zortech C Video Course	PC-DOS	£180
Zortech C++	PC-DOS	£ 90
Aztec C86 Developer	CP/M-86	£230
Aztec C86 Personal	CP/M-86	£130
CI Optimizing C86	CP/M-86	£210
De Smet C Programmer	CP/M-86	£125
Hi-Tech C	CP/M-86	£115
Lattice C	CDOS	£330
HIGH C (Metaware) Flex OS	OS 286	£380
Avocet C	CP/M-80	£185
Aztec C Personal 1.06D	CP/M-80	£110
Aztec Commercial 1.06D	CP/M-80	£180
BDS C 1.60	Z80 + CP/M-80	£ 65
Eco-C v3.5.0	Z80 + CP/M-80	£ 45
Hi-Tech C	Z80 + CP/M-80	£ 99
Mix C	Z80 + CP/M-80	£ 35
Toolworks C/80 v3.1	CP/M-80	£ 40
Aztec C65 V1.05	Apple DOS	£180
Aztec C65 V3.20	Apple PRO-DOS	£230
Aztec C68K MFW C	MACINTOSH	£ 99
Aztec C68K C	MACINTOSH	£ 65
Aztec C68K/AM Developer	AMIGA	£175
Aztec C68K/AM Prof'snl	AMIGA	£120
Aztec C68K/ST Developer	ATARI	£175
Aztec C68K/ST Prof'snl	ATARI	£120
Hi-Tech C	ATARI	£ 99
Lattice C	ATARI	£ 85
Mark Williams C v2	ATARI	£110
Laser C	ATARI	£135
Prospero C	ATARI	£105

C CROSS COMPILERS

We supply 2500AD, Avocet, Aztec, Lattice, IAR and Hi-Tech Cross Compilers hosted on MS-DOS and targeted on Z80, 6502, 6801, 68HC11, 6301, 6809, 7811, 8051, 8096, 68000 & 68020. Please call for information or advice.

C INTERPRETERS

Latest v3.00 of C-terp has improved debugging facilities.

C-terp V3.0X	PC-DOS	£155
Interactive C	PC-DOS	£195
Introducing C	PC-DOS	£ 85
Living C Plus	PC-DOS	£135
Instant-C v3	PC-DOS	£380
Instant-C/16M	PC-DOS	£680
RUN/C	MS-DOS	£ 60
RUN/C Professional	MS-DOS	£110

We can copy files to and from 600 disk formats including CP/M, CP/M-86, MS-DOS, PC-DOS, ISIS, APPLE, SIRIUS, BBC, TORCH, APRICOT, HP-150, TRSDOS, DEC RT-11, IBM BEF, ATARI ST, AMSTRAD, MACINTOSH. Our charge is £10.00 + disk + VAT with discounts on small quantities and disks are normally despatched within 24hrs of receipt. For more information call us.

PRICES & DELIVERY

Prices do not include VAT or other local taxes but do include delivery in UK and Europe. Please check prices at time of order, ads are prepared some weeks before publication.

This page lists some of our products. Call us for a complete pricelist.

Order by phone with your credit card.

PASCAL LANGUAGE

New version of Turbo Pascal with support for the Borland debugger + proper floating point is available

MS Pascal v4.0	OS/2&PC-DOS	£170	Pecan P-Sys w.UCSD Pas.	IBM-PC	£ 80
ALICE Pascal Intrprtr.	PC-DOS	£ 80	Pecan P-Sys Pascal Prof.	IBM-PC	£155
Dr Pascal Interpreter	MS-DOS	£ 39	Metaware Prof.Pascal	Flexos	£415
Metaware Prof.Pascal	MS-DOS	£380	Pro-Pascal v2.14	CP/M-86	£240
Metaware Prof.Pas/386	MS-DOS	£570	Pascal MT+ v5.6	CP/M-80	£ 99
Mystic Pascal v1.6E	PC-DOS	£ 29	Pro-Pascal v2.18	CP/M-80	£240
Oregon Pascal-2	MS-DOS	£295	MCC Pascal	ATARI ST	£ 75
Prospero Pascal v3.15	MS-DOS	£240	Pecan P-Sys w.UCSD Pas	ATARI ST	£ 80
Prospero Pascal for GEM	MS-DOS	£ 85	Pecan P-Sys w.UCSD Pas	APPLE]]	£ 80
Prospero PC Pascal	PC-DOS	£ 85			
SVS Pascal 386	PC-DOS	£570			
Turbo-Pascal v5	PC-DOS	£ 79			

We have many Pascal Libraries. Enquire

CLIBRARIES

Microsoft OS/2 programmers toolkits are now in stock. The C/Database Toolchest from Mix offers some unusual features at a silly price. Greenleaf Mathlib offers BCD maths for business applications.

DATABASE			GENERAL FUNCTIONS		
Btrieve	OS/2	£370	C+0 Class Lib (MS,TC)	PC-DOS	£145
Btrieve v5	MS-DOS	£160	C+0 Cl's Lb (MS)WINDOWS&PC-DOS		£145
Btrieve/Network	MS-DOS	£370	SQL (CTREE,BTRIEVE)s'ce	PC-DOS	£250
SQL	PC-DOS	£510	C-Worthy Int.Lib (L,MS)	MS-DOS	£165
C/Database Toolchest	PC-DOS	£ 29	D-Tree (source)	PC-DOS	£320
CBTREE (source any C)		£100	Greenleaf Functions s'ce	PC-DOS	£ 85
C-Index/Plus (source any C)		£175	G'leaf Super Functions	PC-DOS	£120
C-ISAM (L,MS)	MS-DOS	£210	G'leaf Business Mathlib	PC-DOS	£140
C-to-dBase (source CI)	MS-DOS	£120	Smorgasbord C-food	PC-DOS	£ 65
C-tree (source any C)		£210	Blaise T'ls plus/5.0 (MS)	PC-DOS	£ 80
Essential Btree (s'ce)	PC-DOS	£110	Blaise Turbo C Tools v2	PC-DOS	£ 95
R-tree	MS-DOS	£155	ESI Utility Lib(source)	PC-DOS	£105
db-VISTA III s'gle user	PC-DOS	£520	Entelekon Funct(source)	PC-DOS	£105
db-Query v2 s'gle user	PC-DOS	£520	Phoenix Pforce (source)	PC-DOS	£205
db-FILE (most C's)s'gle	MS-DOS	£295	Pro-C & Workbench	PC-DOS	£595
db-RETRIEVE single-user	MS-DOS	£295	Security Library object	MS-DOS	£110
Lattice dBCIII (L,MS)	MS-DOS	£160	Resident-C (MS,L) (s'ce)	PC-DOS	£120
Lattice dBCIII+ (L,MS)	MS-DOS	£445	The Heap Expander (MS&TC)	PC-DOS	£ 59
SftFcus Btree&Isam (s'ce any C)		£ 80	Zortech Supertext	PC-DOS	£ 39
Virtual Memory File Man.	PC-DOS	£150			
GRAPHICS			COMMS LIBRARIES		
Enhanced Graphics Tlkt	PC-DOS	£170	Blaise C Asynch(source)	PC-DOS	£105
Essential Graphics v2	PC-DOS	£155	Essential Comms (L,MS,T)	PC-DOS	£110
GFX Graphics	PC-DOS	£ 70	Greenleaf Comms(source)	PC-DOS	£100
GraphiC v5 (CI,L,DS,MS)	PC-DOS	£270	Multi Comms (L,MS)	PC-DOS	£105
GSS Kernel system	PC-DOS	£350	Zortech Comms (QC&TC)	PC-DOS	£ 65
GSS Lattice Binding	PC-DOS	£110	Zortech Comms (ZC++&ZC3)	PC-DOS	£ 65
GSS Graph Dev Toolkit	PC-DOS	£350			
GSS Graphic Plotting sys	PC-DOS	£245			
GSX Prog.Toolkit (DR)	PC-DOS	£270			
HALO '88 (MSCS,LAT,TC)	PC-DOS	£180			
MetaWINDOWS (CI,L,MS,T)	PC-DOS	£105			
MetaWINDOWS Plus	PC-DOS	£150			
Turbo WINDOWS/C (Turbo)	PC-DOS	£ 55			
Quick Windows/C (QC)	PC-DOS	£ 55			
SCREEN & WINDOWS			SCIENTIFIC LIBRARIES		
Vitamin C (MS5.1)	OS/2&PC-DOS	£225	Wiley Scientif.Lib.v2	ANY C	£145
Blaise Power Scrn(MS&TC)	PC-DOS	£ 80	Mathpak 87 (L,MS)	MS-DOS	£ 80
Blaise View Mngr. (s'ce)	PC-DOS	£245			
Curses Screen Mngr. (L)	PC-DOS	£120			
Entelekon Windows(s'ce)	PC-DOS	£105			
Multi-windows (MS,L)	PC-DOS	£220			
Panel Plus (source)	PC-DOS	£270			
Vitamin C (source)	PC-DOS	£150			
Vermont Views (MSC,TC)	PC-DOS	£255			
Greenleaf Datawindow	PC-DOS	£135			
Greenleaf MakeForm	PC-DOS	£ 55			
C-Scape v3 (MS,L,TC)	PC-DOS	£300			
Zortech Windows (ZC++&ZC3)	PC-DOS	£ 39			
			PROGRAMMERS UTILITIES		
			PC-Lint	OS/2,MS-DOS	£ 75
			C-Documentor	PC-DOS	£195
			C-Scan	PC-DOS	£195
			C Toolset	MS-DOS	£ 90
			Clear+ for C	PC-DOS	£150
			Lattice Cross Ref.	MS-DOS	£ 40
			Lattice Comp Companion	MS-DOS	£ 65
			REAL TIME & MULTI-TASKING TOOLS		
			Csharp (CI,L,MS) s'ce	MS-DOS	£445
			Concurrent C (PC/MPX) s'ce	MS-DOS	£ 60
			Multi C (L,MS,CI)	PC-DOS	£105
			Op.Sys.T'box (MS) s'ce	PC-DOS	£ 65
			Timeslicer v3.01 (L)	PC-DOS	£160
			Timeslicer v5 (MS)	PC-DOS	£160
			Over-C (L,MS)	PC-DOS	£225

PROGRAMMING TOOLS

Ada Compilers	Algol Compilers
Assemblers & Libs	AWK
Basic Compilers	Basic Interpreters
Basic Utilities	Basic Libraries
BCPL Compilers	C Compilers
C Interpreters	C Libraries
C Utilities	Cobol Compilers
Comms Libraries	Cross Assemblers
Database Libs.	Debuggers
Dis-assemblers	Editors
Engineers Libs.	Expert Systems
Forth	Fortran Compilers
Fortran Libraries	Graphics Libraries
Icon	Linkers/Locaters
Lisp	Modula-2
Nial Interpreters	OPS 5
Pascal Compilers	Pascal Libraries
Prolog	Rexx
Risc	Screen Libraries
Smalltalk	Snobol

We stock many items for which there is no space in these advertisements.

CROSS ASSEMBLERS

We supply cross-assemblers by Avocet, 2500AD, IAR Systems and Pecan hosted on MS-DOS, CP/M-86 and CP/M-80 with over 30 target processors. In total over 200 products with no space to list them here. We hold some stock but you should allow 10-14 days for delivery. Please call for information or advice.

GREY MATTER

4 Prigg Meadow, Ashburton, Devon TQ13 7DF.
TEL. (0364) 53499

GREY MATTER

4 Prigg Meadow, Ashburton, Devon TQ13 7DF.
TEL. (0364) 53499

GREY MATTER

4 Prigg Meadow, Ashburton, Devon TQ13 7DF.
TEL. (0364) 53499



Oops!

CCMI/McGraw Hill's National Tariff Library Service Will Fill in the Blank!

Would you like all the money-saving advantages of keeping up with the tariffs that affect your company's telecommunications costs?

Then let CCMI/McGraw Hill's National Tariff Library Service be your telecommunications planning partner.

At CCMI/McGraw Hill's National Tariff Library Service, we know tariffs. Not just the rates, but the tariff complexities that govern your business telecommunications services. We can help you be sure you'll get the most for your voice/data dollar.

Our National Tariff Library Service provides the most frequently requested U.S. tariff information in a convenient 3-ring binder.

If your requirements are very specialized, we'll focus on the jurisdictions, carriers, and services that matter to *your* company.

You'll never be without the vital tariff information that will save you time and save you money, because our reliable update service keeps you current.

Let the experts at CCMI/McGraw Hill's National Tariff Library Service join your voice/data communications planning team. Call us today at 1 800 526-5307 or 1 201 825-3311.



CCMI/McGraw-Hill

500 North Franklin Turnpike
Ramsey, New Jersey 07446



B I X I S G L O B A L

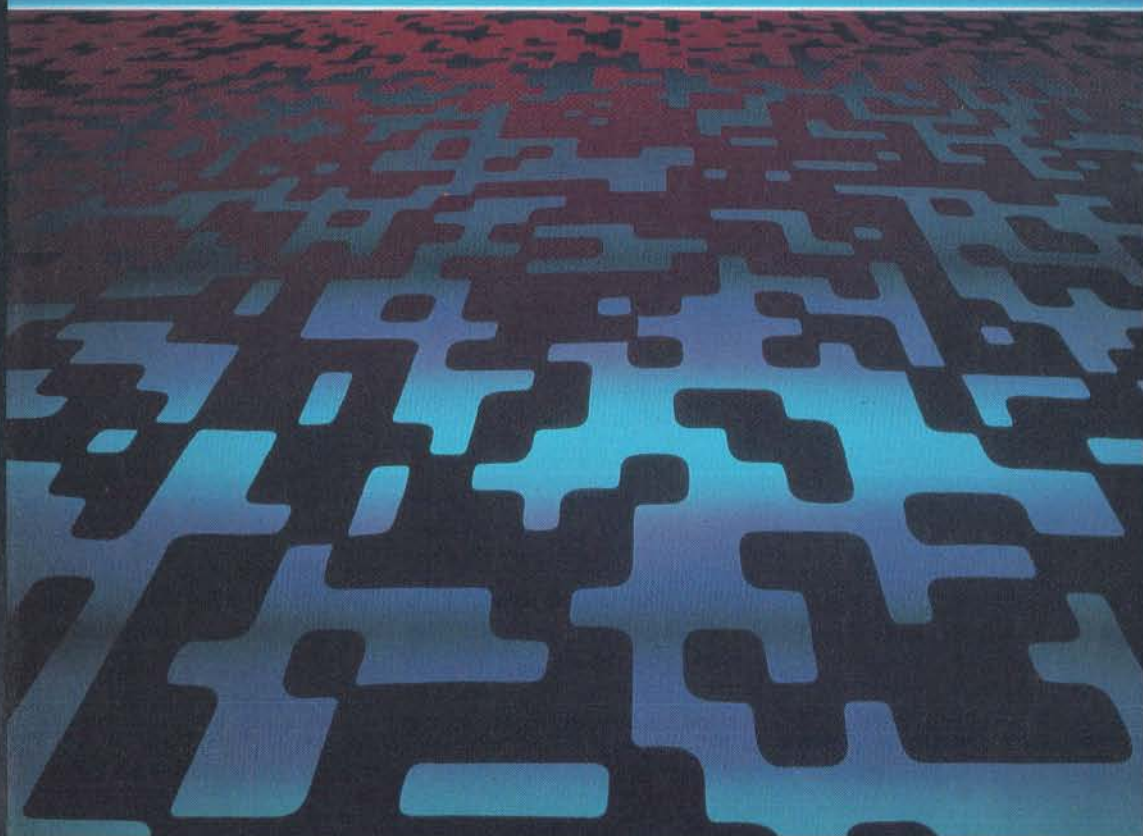

BIX is BYTE's Information Exchange, a worldwide computer conferencing system devoted to the exchange of microcomputer information.

When you use BIX, you leap borders of geography and time to exchange information, opinions and ideas with a "living database" of the world's most knowledgeable microcomputer users.

BIX covers the world.

Our *Microbytes* news service, backed by BYTE and McGraw-Hill, provides

worldwide daily news coverage of major events in the microcomputer industry plus listings of thousands of new products from vendors around the globe. Scores of companies now use BIX to provide technical support for their hardware and software products worldwide.

BIX saves you time.

BIX resources help you get the micro-related information you need right away, regardless of your location. BIX electronic mail lets you send private messages to

other BIX users worldwide. For more information on how to join and use BIX from your country, read the BIX message in this issue (see Advertiser Index for page number), or contact us today.

BIX

BYTE INFORMATION EXCHANGE

One Phoenix Mill Lane
Peterborough, NH 03458 USA
(603) 924-7681 (Our overseas
helpline number)
8:30 AM-11:00 PM
Eastern Time
(-5 GMT) Weekdays



Flag Down 113,000 International Product Specifiers—75,500 in Europe—for Just Pennies Per Contact!

BYTE's International Section reaches over 113,000 BYTE paid readers outside of North America. 75,500 of these influential readers are located in Europe. What's more, 89% of the European readers are directly involved in their companies' plans to purchase personal computers and related products. And, BYTE's monthly International Section has built-in direct response capabilities.

Three Cents Per Contact!

The adjacent International Direct Response Postcards provide a vehicle that encourages your prospects to respond to you. All replies are sent directly to your company. The cost to you is less than three cents per contact!

In addition to the international postcards are Reader Service Cards. They generate pre-qualified sales leads for your ads and new products. These leads are collected in our processing center in Birmingham, England, so you'll get them as quickly as possible, all at no cost to you.

Are You Ready For 1992?

In 1987, the European personal computer market grew by 66% to over 10 billion dollars. By 1992, trade restrictions will be removed within the European community resulting in unprecedented activity and expansion within the pan-European marketplace. BYTE's International Section presents the perfect opportunity to sell your

products to the most important computer decision makers across Europe.

Low Advertising Costs

Advertise in BYTE's International Section for as low as \$500 for a one-time 5.1 cm x 7.6 cm ad...to \$3,890 for a one-time full page ad (that's only five cents per contact!).

Call Karen Lennie or Roz Weyman (German-speaking) in the U.K. today at 01-493-1451. Reach the product specifiers that only BYTE can attract.

BYTE 

Readers! Use these Postcards for Fast Response

Just fill out the adjacent postcards of interest to you, affix postage and place in the mail. Or, for even faster response, call the companies directly through the telephone numbers indicated on each card.



SHORT TAKES

BYTE editors' hands-on views of new products

Dell 325

Volkswriter 4

ComputerEyes

DataFinder and
ScriptView

NeuroShell

System Sleuth



A Quality 80386 Machine

It seems like everybody is selling a 25-MHz 80386-based computer these days. Unfortunately, the quality of such systems varies tremendously. The worst machines are mere assemblies of available parts; the best ones are built with regard for performance and reliability. One of the best that I've seen is the **Dell 325**.

Dell has managed to assemble all the most-wanted features into one system. The Dell 325 I looked at contained an 80386 running at 25 MHz and 2 megabytes of RAM, which was composed of eight 256K-byte single in-line memory modules arranged in an interleaved memory architecture to speed memory access.

There is a socket for an Intel 80387 math coprocessor (a Weitek 3167 math coprocessor is optional). An 82385 cache memory controller and 32K bytes of 25-nanosecond static RAM for the cache speed memory accesses. All this is situated on a motherboard that contains the Chips & Technologies chip set, a Phoenix ROM BIOS, two serial ports and one parallel

THE FACTS

Dell 325
base system, \$4599

Options:
Weitek 3167 math
coprocessor, \$1300; Intel
25-MHz 80387 math
coprocessor, \$1000; 1
megabyte of RAM,

\$480; additional floppy
disk drive, \$130.

Dell Computer Corp.
9505 Arboretum Blvd.
Austin, TX 78759
(800) 426-5150
Inquiry 1024.

port, and eight slots (two 8-bit and six 16-bit).

The system also came with an 18-millisecond Micropolis Model 1558-14 318-megabyte hard disk drive and two floppy disk drives (1.2-megabyte 5¼-inch and 1.44-megabyte 3½-inch). The drives are con-

nected to a Western Digital floppy disk/ESDI hard disk controller card.

Video output is controlled by a Video Seven 16-bit VGA card and displayed on a Dell VGA Color Plus Monitor. Also included is a Key Tronic 101-key Enhanced keyboard.

The Dell 325's base system comes with 1 megabyte of RAM, a 1.2-megabyte floppy disk drive, and a Western Digital controller card.

Setting up and using the Dell 325 was simple. Every part of the system is documented, and everything was in working order out of the box. It comes with a one-year limited warranty, and toll-free technical support is offered.

In performance, the Dell 325 was as fast as any other 80386 computer I've used. The BYTE benchmarks rate the machine as roughly equivalent to—if not faster than—the Compaq Deskpro 386/25.

All this performance comes in a package that costs one-third less than a comparable Deskpro 386/25. The Dell system I used cost \$9308. This low price is partly the result of recent price cuts made by Dell for large hard disk drives and partly because of the decrease in the cost of DRAM chips.

Dell recently announced that it will offer a Unix version of this system. The option includes a merged version of Unix System V 3.2, which can run all Xenix applications, in addition to AT&T System V/80386 programs. This system will also support X Windows.

The Dell 325 is a fine combination of hardware that provides very good performance at a reasonable price.

—Stan Wszola

It's a Word Processor and, Its Also a Grammar Checker

No, that title didn't slip past the copy desk. It did, however, slip past Perfect Grammar, which is the grammar-checking program bundled with Lifetree Software's **Volkswriter 4** word proces-

sor. Perfect Grammar is useful for cleaning up carelessly worded text, but it's no substitute for a copy editor or a judicious proofreader.

To test Perfect Grammar, I created two documents with

the aid of *The Elements of Style* by Strunk and White. The first 2100-word document violated all of Strunk and White's rules, and the second document conformed to them.

continued

In addition to common grammatical errors like "its" for "it's," the bad test file included stylistic problems like wordiness and entire paragraphs written in the passive voice.

Perfect Grammar checks grammar and spelling, highlighting mistakes and suggesting corrections. In most cases, you have the option to accept the correction, ignore the suggestion, or edit the offending word or phrase yourself. Since you're given the final say, you always have full control over style; you can even set the checker to never flag unorthodox constructs that you often use.

The program missed obvious mistakes and occasionally flagged correct expressions. No grammar checker can read your mind, but how much stock can you put in software that passes over "Morris's uncle, Albert keeps pet piranha" and suggests "reads" for "read" in "The man unfolded the contract and read it to me"? If you can't rely on the program in simple cases like these, you're not likely to take its suggestions when the grammar questions become more difficult.

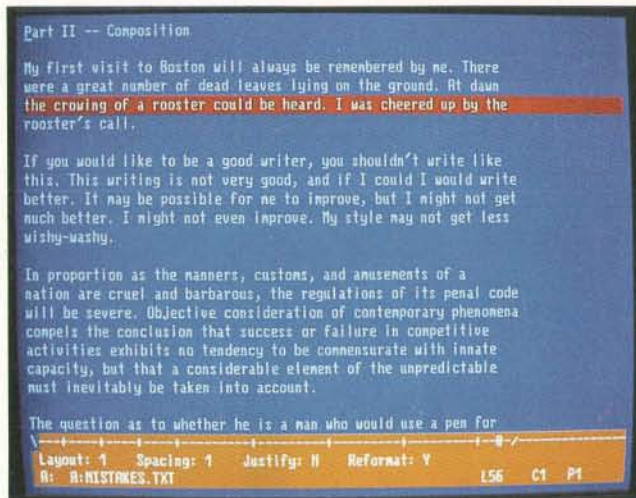

THE FACTS

Volkswriter 4 with Perfect Grammar
\$199

Requirements:
IBM PC with DOS 2.0 or higher and 640K bytes of RAM with 540K bytes free, or 384K bytes

with 328K bytes free to run without Perfect Grammar.

Lifetree Software, Inc.
411 Pacific St.
Monterey, CA 93940
(408) 373-4718
Inquiry 1025.

Perfect Grammar also fails to detect errors that extend beyond one sentence. Varying verb tense in a single paragraph is an example. It doesn't

flag strings of passive-voice sentences or paragraphs of sentences that begin with the same word.

While it rightfully takes ex-

ception to "the reason why is ..." as wordy, it doesn't object to repeated sentences containing "the fact that" or "certainly." It also accepts ridiculously complex wording and jargon.

In addition to the grammar checker, Volkswriter 4 adds a few interesting features to the usual word processor's repertoire of editing and block manipulation. These include math functions, sorts, text merges, and an ASCII conversion utility. The package supports over 400 printers and can take advantage of advanced printer features like proportional spacing and PostScript.

Volkswriter 4 is both easy to learn and easy to use. Thus, even if you're fiercely loyal to other word processing software (as most of us are), you won't have much trouble making the adjustment.

If you expect Perfect Grammar to dramatically improve your writing, you'll probably be disappointed. If, on the other hand, you're looking for a good word processor with a sophisticated diagnostic tool, Volkswriter 4 with Perfect Grammar may be the answer.

—Steve Apiki

Low-Cost Digitizing on the Mac

With the **ComputerEyes** video digitizer from Digital Vision, you can now get 8-bit digitizing with 256 gray levels for the price of 1-bit digitizers. There are some obvious trade-offs, like speed, but even that isn't too bad.

ComputerEyes scans at 300

dots per inch in 24 seconds, or 6 seconds for the fast graphics scan (at about 72 dpi). This is not, however, a frame-capture board that will take one-thirtieth of a second's worth of TV and digitize it. If your subject moves appreciably during the scan, it will show a smear. If

you have recorded a moving subject on videotape, you might be able to use this device on the playback for digitization. If you want to digitize nonmoving subjects like plants, it's no problem.

The digitizer measures 5½ by 5 by 2 inches. It comes with a small 12-volt DC wall-hung power supply, a cable with an RCA phono plug on each end that you can plug into a printer or a modem, a Macintosh disk, and a manual. You plug the digitizer into a mini-8 Mac serial port.

The manual goes over the basic installation procedures and common troubleshooting areas, but it doesn't go into depth on any subject. The

overview section is probably the best part of the manual, since it explains what is being done by the digitizer and how to use the gray-level editing

continued

THE FACTS

ComputerEyes
\$249.95

Requirements:
Any Mac with 1 megabyte of RAM.

Digital Vision, Inc.
66 Eastern Ave.
Dedham, MA 02026
(800) 346-0090
Inquiry 1026.





Embedded systems designers have already used CrossCode C in over 357 different applications.

CrossCode C comes with four powerful tools to help you program your 68000-based ROMable applications

From C source to final object, each tool takes you one step closer to your finished ROMable design

CrossCode C is designed specifically to help you write ROMable code for all members of the Motorola 68000 family. Four powerful tools take you from C source to object code:

1. COMPILER: To get truly ROMable code, you have to start with a truly ROMable compiler. Here are three **CrossCode C** features that you won't find in any ordinary C compiler:

- Compiler output code is split into five independent memory sections that you can assign into ROM or RAM as you please.
- You can optimize the code for your application because you control the sizes of data types. For example, you can optimize for speed by using two byte *ints*, or get maximum versatility by using four byte *ints*.
- You can easily write assembly language routines that call C functions and vice versa, because the compiler uses simple, well documented parameter passing conventions.

2. ASSEMBLER: **CrossCode C** comes with a Motorola-style assembler that has all the features that assembly language programmers require. In fact,

you could write your whole application with it:

- The assembler features an advanced macro language, conditional assembly, "include" files, and an unlimited size symbol table.
- Detailed cross references show you where you've defined and referenced your symbols.
- After a link, you can actually convert your "relocatable" assembler listings into "absolute" listings that contain absolute addresses and fully linked object code.

3. LINKER: The **CrossCode C** linker is designed to handle truly huge loads. There are no limits on the number of symbols in your load or on the size of your output file. And you can always count on full 32 bit target addressability, because the linker operates comfortably in the highest ranges of the 68030's address space.

4. DOWNLOADER: **CrossCode C** comes with a *downloader* that puts you in touch with all EPROM programmers and emulators. It can convert your load into Motorola S-Records, Intel Hex, Tek Hex, Extended Tek Hex, and Data I/O ASCII

Hex. You can also produce a binary image and convert that image into any format you might want. In all formats, bytes can be split into EPROMs for an 8, 16, or 32 bit data bus.

Why Wait

Once you start using **CrossCode C**, you may just wonder how you ever got the job done before! It's available under MS-DOS for just \$1595, and it runs on all IBM PCs and compatibles (640K memory and hard disk are required). Also available under UNIX, XENIX, and VMS.

CALL TODAY for more information:

1-800-448-7733
(ask for extension 2002)

Outside the United States, please dial

PHONE: 1-312-971-8170
FAX: 1-312-971-8513

SOFTWARE DEVELOPMENT SYSTEMS, INC.
DEPARTMENT 22
4248 BELLE AIRE LANE
DOWNERS GROVE, ILLINOIS 60515 USA

CrossCode™ is a trademark of SOFTWARE DEVELOPMENT SYSTEMS, INC. MS-DOS® is a registered trademark of Microsoft. UNIX® is a registered trademark of AT&T. XENIX® is a registered trademark of Microsoft.

program that is included.

The ComputerEyes program controls the image capturing, as well as the first editing of the image. Brightness and contrast are adjustments that will affect all images, and they are done with small sliders that give numeric values as they move. A "normal" view screen and a "full" view screen are available. Normal view is 1 pixel per sample; the full view shows the overall document. We found this to be a useful setup.

Similar editing programs require you to toggle back and forth between these views to get an idea if a small change works with the entire document. ComputerEyes gives these views simultaneously in their own windows and makes editing much easier.

Files can be saved as MacPaint, PICT, TIFF, or PostScript, although ComputerEyes will not read a PostScript file back into the editor portion of the program.

There is also a preview

mode that scans a subject and is useful for camera adjustments, like framing the subject. Since the output is not saved in memory, it effectively scans somewhat faster.

You can mirror, flip, or invert all or part of an image with simple menu commands. Also, you can apply halftone, 64-level dither, randomized dither, a vertical venetian-blind effect, and a horizontal venetian-blind effect. These are simple but useful patterns, with the halftone being the one

that was our favorite.

All in all, we found a lot to like about ComputerEyes. It is affordable for individual use, while capable of producing no-compromise files that you can use in high-end publishing applications. We think it truly represents a price/performance breakthrough for Mac peripherals, and we can foresee many users wanting a 256-gray-level digitizer at this price.

—Laurence H. Loeb and
Anne Fischer Lent

A Pair of Paradox Helpers

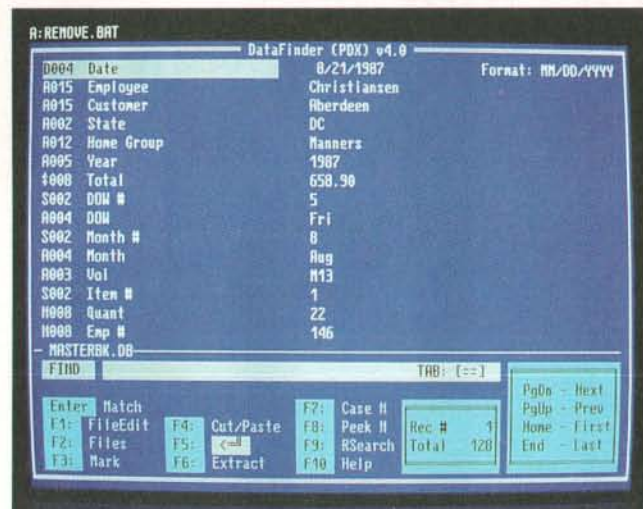

The power and complexity of packages like Paradox sometimes make them difficult to use, and that has created a large market for utilities like **DataFinder** and **ScriptView**.

TSR Systems' DataFinder is a memory-resident utility that lets me directly manipulate a Paradox file from outside Paradox. When I'm writing a letter, I often need to retrieve an individual's name and address. That requires that I do the following: start Paradox, find the name, put it into a report, and output it in ASCII. I used to think it was easier to use my Rolodex... until I tried DataFinder.

I can pop up DataFinder, find the name and address I need, mark it, cut it, and paste it directly into my letter—in

mere seconds. I can also extract financial data and paste it into my spreadsheets.

DataFinder also lets me create a new file from data I've marked, and I can quickly edit

data in a Paradox file without having to start the main program. In a pinch, DataFinder adds power to Paradox.

Another useful utility that has helped me develop custom

Paradox applications using PAL (Paradox Applications Language) is ScriptView. Although PAL is a powerful language, it is complex. When I'm trying to debug a complex PAL script, I've often wished I could have the software tools available in regular programming languages. ScriptView fills the bill nicely.

ScriptView creates a graphical program structure from a PAL script and gives me three types of variable cross-reference listings, procedure call tree diagrams, and procedure usage reports. There are also project lists that document the entire application. If you develop PAL scripts, ScriptView is a necessity.

—Stan Miastkowski
continued

THE FACTS

DataFinder
\$99.95

Requirements:
IBM PC with a hard disk drive and Paradox (any version).

TSR Systems, Ltd.
1600B Main St.
Port Jefferson, NY
11777
(516) 331-6336
Inquiry 1027.

ScriptView
\$95

Requirements:
IBM PC with a hard disk drive and Paradox (any version).

Farpoint Systems Corp.
P.O. Box 13093
Jersey City, NJ 07303
(800) 336-6644; in New Jersey, (201) 659-7613
Inquiry 1028.

NOW YOU CAN DESIGN JUST ABOUT ANYTHING... INCLUDING YOUR OWN CADD SYSTEM!

PC
MAGAZINE
EDITORS
CHOICE
CADD
3.0



See us at Booth #2201

A/E/C SYSTEMS®'89

June 6-8 Anaheim, CA Convention Center

Anyone can produce a computer-aided drafting and design package that sells for thousands of dollars. But creating one that's fast, powerful, and affordable takes real ingenuity.

That's exactly what we've done at Generic Software.™ We sell the most widely used CADD program in the world for under \$500.

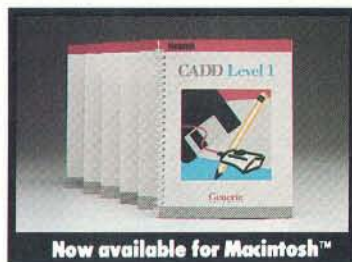

Now available for Macintosh™

PC Magazine ranked it "Editors Choice" in a face off with 17 low-cost CADD packages. "This product is an outstanding value from every point of view and is highly recommended." "A paperback version of AutoCAD", stated PC Week.

And our CADD programs are just part of what we offer.

You can start with Generic CADD Level 1,™ then advance to other levels as your needs—and skills—expand.

And you can use our CADD add-ons, Utilities, and symbols libraries to design the CADD system that fits your needs.

You only pay for the functionality you need, and the functionality you get has depth.

Critic tested, market approved. Generic Software offers price, quality, and support. Match our customer support against anyone!

- Unconditional 60-day guarantee on most products
- Unlimited free technical support
- Free monthly newspaper
- Regular updates at modest prices. All adding up to prove that the only thing generic about us is the price.

Call us for a free CADDalog™ or for the name of your local dealer: 1-800-228-3601.

© Generic Software Inc., Level 1 and Generic CADD are trademarks of Generic Software Inc., 11911 North Creek Parkway South, Bothell, WA 98011. Macintosh is a trademark of Apple Computer Inc.

Generic
S O F T W A R E

NEW FROM NOVAS



HONORED BY PC MAGAZINE

"...It gave better performance than ALL the machines of this group on most of the processor benchmark tests..."

"...Working my way down the tower, I found a 'NOVAS SUPER TURBO 286X MOTHERBOARD'..."

"...It's so flexible that it makes living without a big name no chore at all..."



NOVAS
286-14MHz System
Starting at ... \$1195

NOVAS
286-20MHz System
Starting at ... \$1595.

NOVAS
386-25MHz System
Starting at ... \$2295

NEVER MORE THAN ... \$495

NOVAS 386 MOTHERBOARD Available in 25/20/16MHz versions

- 80386 by Intel, AMI Bios, EMS Support
- Chips & Technologies 386 CHIPset, sockets for 80287 & 80387/Weitek
- Expandable to 16MB (Simms) on board, Interleave/page mode memory 0 wait state
- Shadow RAM, Independent Clock, On board battery, 8 I/O expansion slots
- 1 serial & 1 parallel port on board (optional 2nd serial port). STARTING AT ... \$895

NOVAS 286 NEAT MOTHERBOARD available in 20/16/14MHz versions

- 80286 CMOS by Harris, AMI Bios, EMS 4.0 support
- Chips & Technologies 286 NEAT CHIPset, socket for 80287
- Expandable to 8MB (Simms) on board, Interleave/page mode memory 0 wait state
- Shadow RAM, Independent Clock, On board battery, 8 I/O expansion slots
- 1 serial & 1 parallel port on board (3 more optional serial ports). STARTING AT ... \$345

NOVAS 4000 SUPER VGA 16 BIT CARD

- 100% IBM compatibility at register plus gate level, Shadow RAM
- Expandable to 1MB of display memory, Supports 132 columns for Lotus 1,2,3
- Chips and Technologies 450 VGA product line chips, Analog & Digital Outputs
- 640 x 480 in 256 colors, 800 x 600 in 16 colors, 1024 x 768 in 4 colors
- Backward capability to EGA, CGA, Hercules, and MDA. NEVER MORE THAN ... \$395

NOVAS 386-20MHz w/64k CACHE CONTROLLER

- Increases performance up to 25% NEVER MORE THAN ... \$1495.

"...FULLY LICENSED TO UTILIZE  PATENTS..."

NOVAS

Quality Products From
COMPUTRADE CO.
780 MONTAGUE EXPRESSWAY,
SUITE 501, SAN JOSE, CA 95131

OEM, VARS, & DEALERS WELCOME
Corporate & University Discounts

*Service in USA

*VGA, XT, AT & IBM are trademarks of
International Business Machines
*Prices & specs subject to change

U.S. SALES: (408) 435-2662
U.S. FAX: (408) 435-5458

Solving the Nearly Unsolvable

NeuroShell from Ward Systems Group is a program that lets you create and solve your own problems using neural-network technology—a way of resolving issues and dilemmas that are difficult to answer with a simple yes or no. Unlike some other computational methods, neural networks don't require programming, because they are based on models of how the brain encodes and processes information. Instead, you "train" them by inputting and outputting desired behavioral information related to your current problem.

You can use neural networks to solve market trends and analysis problems, to decide on certain goods to purchase, to establish people's ability to qualify for or repay a loan, and to handle other dilemmas with several variables that may not have absolutely "correct" answers.

NeuroShell includes binary and analog versions. Generally, the binary version is more useful because you can input words and strings; the analog version requires that you assign numbers. However, you can try your problem both ways.

I installed the program easily and began using its Main and Advanced Options menus. With the Main menu and the manual, I went through some binary and analog examples included on the disk and then ran the sample cases provided. The manual warns you that unless you use a math coprocessor, learning will take a while, and it did—an hour for the simple case I chose.

To set up a new problem, you create a number of sample cases by inputting various defining characteristics above a dotted line and classifying characteristics below the line. Next, in each sample case, you enter certain combinations of defining and classifying characteristics. Then, in order to input your new and unproven questions, you have the pro-

gram learn these givens by selecting the menu item "Learn the sample cases."

You then sit back and watch as NeuroShell makes your inputs and outputs "converge" to a certain default (or custom-chosen) threshold. Unless and until you override other default criteria (e.g., the amount of hidden nodes and minimum and maximum characteristics and thresholds), the program uses preset values.

NeuroShell gives you screens that show you all your options and ranges and information on how to adjust the data if you find the program's responses to be off a bit.

After its learning period, you can enter certain characteristics and use the F3 key to classify or respond to the various combinations you choose. If the answers are off a bit, you can wipe out the old stuff, start over or modify the data, and have the program learn the new information. The time the program takes to learn decreases with each new try.

I've used many of the other available neural-network simulations, and I'm glad that NeuroShell doesn't include graphics. The only function graphics provide is to let you watch the program's neurons interconnect.

I like the fact that NeuroShell does something.

—Janet J. Barron
continued

THE FACTS

NeuroShell
\$195

Requirements:

IBM PC or compatible with 256K bytes of RAM and DOS 2.0 or higher. A math coprocessor is recommended.

Ward Systems Group
8013 Meadowview Dr.
Frederick, MD 21701
(301) 662-7950
Inquiry 1029.

Sometimes even the most advanced technology starts with a simple idea.



Finding a way to make a printer with laser quality, but without laser cost, was no easy task. So when Canon engineers designed the BJ-130, they were quite surprised to find such a simple answer. Bubbles. Millions of tiny ink bubbles, in fact, that quickly and quietly print at up to 360 DPI for performance that's almost unheard of in a non-impact printer.

The BJ-130 Bubble-Jet Printer provides incredibly precise print quality for everything from text to graphics and lets you print on just about any plain paper you choose. Even paper as wide as 16.5 inches,



Canon
BJ-130
Bubble-Jet Printer

thanks to a 136-character/line carriage that's the widest in its class. And when it comes to virtually maintenance-free performance the BJ-130 is also in a class by itself, with built-in automatic cleaning and a unique 48-nozzle print head that lasts for years. Along with high speed operation that's so quiet you can keep the unit right by your desk, convenient cut-sheet feeding plus complete software compatibility, the BJ-130 Bubble-Jet Printer is simply faster, simply quieter, simply clearer. Quite simply, it's a better way to print.

For more information, call the Bubble-Jet Hot Line 1-800-453-7000

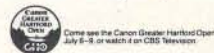

NEW FOR TURBO C PROGRAMMERS

Three Serious Tools

at a ridiculously low price.

Your time is valuable! Now you can reduce your programming time like you never imagined, using The Working Toolbox Software program by Be Aware Inc. Our program comes with an extensive, easy-to-use manual that is loaded with examples. Also included is a 30-day money back guarantee. Here are some of the features of these three great timesaving tools.

THE WORKING TOOLBOX

THE WORKING ISAM

- Stores data in B+ Trees.
- Maximum of 256 indexes.
- RAM buffers for high speed.
- 6 types of indexes available.
- Multi-field indexing.
- All indexes stored in one file.
- Automatic Recovery.
- FREE SOURCE CODE

THE WORKING SCREEN PAINTER

- Friendly interactive environment.
- Data entry and display.
- Box & line drawing supported.
- Multi color screens at a glance!
- SUPER FAST SCREENS
- Writes C source code ready to be compiled under any memory model.

THE HANDY LIBRARY

- Great functions for easier programming and professional results.
- Intelligent data entry and display.
- Overlapping windows
- Pop Up, Pull down and bar menus with one function call!
- All memory models supported.
- Date conversion functions.

So don't waste any more time, order now! Only \$79.99 plus shipping and handling. Call (our toll-free number) or fax your order.

Be Aware Inc.

1443 Banks Road, Margate, FL 33063

No Royalties! ORDER NOW ONLY \$79.99

1 800-423-1611 or 305-970-0372

or FAX 305-735-3459

Turbo C is a registered trademark of Borland International.

SHORT TAKES

Sleuthing Your Troubles Away

I made the mistake of customizing a new machine with parts cannibalized from my old system. In the end, I had a computer with a decent-size hard disk drive, 1.5 megabytes of RAM, a second communications port, the old monitor I had gotten used to, and a persistent configuration error.

After several failed attempts at reconfiguring the system with the Setup menu, I was seriously considering the possibility that I had a defective piece of equipment.

In the middle of all my confusion, I received a new system utility package, **System Sleuth** from DTG. I quickly read the brief, literate instructions and prepared to give the computer a new lease on life.

What happened next was relatively simple, although still somewhat perplexing. I'd set the video board to "monochrome" for a monochrome monitor and set the configuration menu for "mono." The video configuration that the system wanted was specified on the Setup menu as "EGA in monochrome mode" while leaving the video-card DIP switches still set for "mono." In my haste, I'd overlooked that configuration possibility when I set up the new system and, since the display screen looked just fine, never considered that it could be the source of the problems I experienced thereafter. After all, a component that looks like it's working properly is easier to ignore as a potential source of your problems.

System Sleuth's way of handling the problems it finds is simply to point out what the error is and (sometimes) suggest a course of action. In my case, I ran Setup one more time, reset the monitor type to EGA, and haven't had a failure since.

There may be many programs that will pinpoint a configuration error and suggest a remedy. The ones I'm familiar with, however, require that

you have a fairly good idea where to look before you run them. What I like about System Sleuth is that it doesn't require you to know beforehand where the source of the problem lies.

My problem was with a part of the system that seemed to be working perfectly, and it would have been the last place I'd have looked for trouble. By being a generalized package that tests each component, System Sleuth saved me a lot of time. It comes with a suite of tests for memory, peripherals, disks, I/O, processors, displays, and much more.

I also like the fact that System Sleuth is passive. It told me what the problem was and let me go fix it. Packages that try to perform automatic repairs can be effective, but I like pushing the buttons and following along with the progress of a fix myself. Whether it's true or not, I feel as if I'm learning something and doing more than just going along for the ride.

If you don't have a lot of time to waste playing system sleuth yourself, but feel like having at least something to say about your system's repairs, System Sleuth could be worth a look.

—Glenn Hartwig ■

We do Windows

Finally, full-featured communications software for Microsoft's Windows

ape (A Programmable Emulator)

- Powerful! Easy-to-use scripting
- Multiple scripts can run concurrently
- Multi-national character set support
- A wide variety of terminal emulations
- Can act as an information switch using DDE
- XModem, XModem1K, YModem, and Kermit protocols
- Built-in line monitor and data capture facility

HI-Q
INTERNATIONAL

1142 Pelican Bay Drive, Daytona Beach, Florida 32019

1-904-756-8988

Site licensing & dealer inquiries welcome

In Europe call TeleSIGMA AB 46-8-735-8560



THE BUS STOPS HERE!

CompuStar: PS/2 and PC/AT Compatibility.

Ask any computer expert about what type of system you should buy nowadays and you'll likely get a "pass the bus" response. Something like — "Well, uh, the PC/AT* bus is your best buy but, then again, the new PS/2* bus may become the next industry standard." Great advice, right? If trying to decide on a microprocessor weren't tough enough, now you're expected to pick a bus, too.

RELAX, NOW THERE'S COMPUSTAR®.

The all new CompuStar from Wells American not only lets you interchange microprocessors, you can also mix and match buses — a PC/AT bus, a PS/2 bus or... both. As your computing needs change, simply snap in a new processor or add an extra bus. You'll never again have to worry about buying the *wrong* computer system!

FOUR COMPLETE SYSTEMS IN ONE.

The CompuStar can be configured with any of four microprocessors — an 8086, an 80286, an 80386SX, or an 80386. The processor and up to 16 megabytes of user memory have all been combined, using the latest VLSI technology, on a single, plug-in CPU module. Plus, any time during the first year of ownership, CompuStar users can "trade-in" the CPU module they initially selected toward the purchase of any of the other more powerful modules. *Nobody* but Wells American gives you this kind of value.

A CONVERTIBLE BUS? YOU'RE KIDDING!

No, we're not. In fact, it may well be the most practical microcomputer innovation ever. Say you've selected an AT compatible CompuStar and later want to add PS/2 compatibility. No problem! Snap in a PS/2 Bus and Adapter Module and you can use *both* buses in the same system. Likewise, if you've selected a PS/2 compatible CompuStar and decide you want to add an AT bus, just snap in an AT Bus Module. Depending on configuration, the CompuStar can have up to 13 bus expansion slots — all AT slots, all PS/2 slots or a "split-bus" of AT and PS/2 slots. No matter which bus becomes the next industry "standard," you'll have peace of mind knowing your investment in a CompuStar will be protected.



The CompuStar is also easily expanded. That's because there are seven CompuStar disk/tape compartments — six accessible from the front and an additional full-height bay inside. All this in a sleek, compact tower design that will leave *more* room on your desktop than any of the so-called "desktop" models.

A NEW IDEA FROM AN OLD COMPANY.

The CompuStar® Multi-Processor, Convertible Bus™ Microcomputer. It's no surprise that our engineers invented it. After all, we've been making microcomputers longer than anyone else... even longer than IBM! And if that kind of experience doesn't impress you, CompuStar's service programmes surely will. You can select an optional overnight module swap-out plan or on-site service from a reputable UK maintenance firm with more than 70 trained engineers dispatched throughout the UK. And, of course, every CompuStar carries a full one-year factory warranty.

FINALLY, AFFORDABLE TECHNOLOGY.

Think all this technology sounds expensive? It's not. Thanks to CompuStar's modular architecture, you pay only for the technology you need — and *only* when you need it.

Plus, there is a wide variety of CompuStar display, tape and disk options including a one gigabyte erasable optical disk. You can choose a factory pre-configured CompuStar or custom design one yourself. Just unlock the front panel and literally "snap-in" a bus, CPU, memory or disk module in a matter of seconds. It's system flexibility never before available... at *any* price.

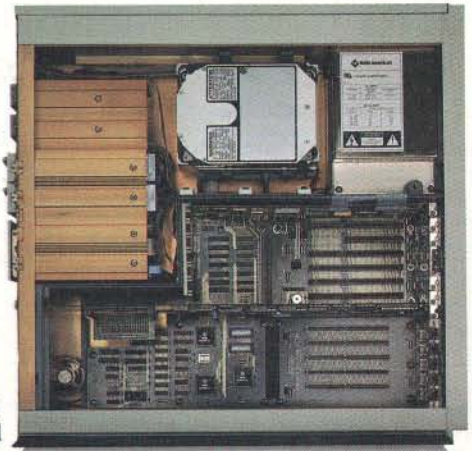

While one of our competitors (we won't mention any names) threatens you with "missing the bus," most simply *pass* the bus. Our new CompuStar, however, *eliminates* the bus problem altogether. Not to mention the processor problem. Even the expansion problem. Prove it to yourself. Call today about our 31-day trial offer. Oh, and by the way, the next time anyone asks, tell 'em you know where the bus stops.



Wells American.

Wells American International, Ltd.
Victoria House, Desborough St.
High Wycombe, Bucks., HP11 2NF
TEL: (0494) 26211 • FAX (0494) 459540

*Personal Computer AT, AT and PS/2 are trademarks of International Business Machines Corporation.

CMO... Your Nationwide Source

PC/100



BASIC SYSTEM CONFIGURATION:

- Intel 8088, 10 MHz Speed
- 640K, Expandable to 1640K
- 360K Floppy Disk Drive
- Floppy Disk Drive Controller
- Clock Calendar with Battery Backup
- 150 Watt Power Supply
- MS-DOS & GW-Basic
- 4 Half Height Front Storage Slots
- 102-Key Switchable Keyboard
- 3-In-One Video Adapter

MONITOR:

- 14" Color RGB
- Tilt & Swivel Base
- 80 x 25 Display
- Green Text Switch

SYSTEM PRICE
\$869

AMIGA

Anakin Research	
Easyl Drawing/2000	\$349
Easyl Drawing/500	319
C.LTD	
Keyboard w/Macros	99
Laser Xpress	2149
Digital Creations	
Supergen	709
Great Valley Products	
A2000 - 2/2	759
A2000 HC/40M	719
A2000 HC/40Q	859
A500 HD/30	799
A500 HD/40M	969
Megatronics	
3½" External Air Drive	149
3½" Internal Air Drive	119
Microbotics	
Starboard II w/512K	449
Upperdeck	45
Progressive Peripherals	
Pro-Gen Genlock	389

Frame Grabber	\$319
Spirit Technology	
1.5MB Bd. w/OK (A1000)	245
1.5MB Bd. w/OK (A500)	245

MACINTOSH

Olympia	
NP-30 Mac 150cps	289
Seikosha	
SP-1000AP Mac	239
Everex	
EMAC 20 Deluxe 20MB	579
EMAC 60T 60MB Backup	799
PCPC	
45MB SCSI Hard Drive	859
Cornerstone	
SinglePage Display SE	759
DualPage Display SE	1259
Magnavox	
9CM080 14" VGA Display	499
RasterOps	
1948S Trinitron	3395
Sigma Designs	
PageView SE	849

LaserView II	\$1899
New Image Technology	
MacScan Pro Sheetfeed	1299
MacScan Pro Flatbed	2089
Practical Peripherals	
Mac 2400 Stand Alone	239
Shiva	
NetModem V2400	429

MONITORS

Amdek	
Video 210 Amber	85
Video 410 TTL Monochrome	145
Video 432 VGA Monochrome	149
Color 732 VGA Color	399
Cornerstone	
SinglePage Display	699
Magnavox	
7BM623 12" TTL Amber	89
9CM053 14" HiRes EGA	369
9CM062 14" VGA Display	349
9CM082 14" VGA Display	399
NEC	
JC-1403 Multisync IIA	519
Packard Bell	
PB-1272 12" TTL Mono	80
PB-1472 14" TTL 132 Col.	109
PB-1422EG 14" HiRes EGA	359



MAGNAVOX
CM8762 14" Comp/
RGB \$235

Polaroid	
Palette EGA Plus	2199
Seiko Instruments	
CM-1430 14" VGA	559
Taxan	
119 12" Composite Amber Mono.	89
770+ MultiVision Display	489
Wyse Terminals	
WY-30, 50, 60	Call
Zenith	
ZFM-1490 14" VGA Analog	619

MULTIFUNCTION

ATD-ZuckerBoard	
Color Half Card	69
Monochrome Graphics Adpt.	79

AST	
Six Pak Plus Board	\$125
VGA Plus Adapter	389
Boca Research	
TopHat 128K Expansion	119
BocaRam/AT 0-4MB Board	149
Boca Dual Graphics Adapter	69
Boca MultiEGA	189
DCA	
Irma 2 3278 Board	699



INTEL
8087 IBM PC/XT CoP.
\$89

Emerald	
3XTwin 5251 Local Emulat.	549
Everex	
Magic I/O AT Par/Ser	59
Ram 3000 Deluxe 0-3MB Bd.	89
Micro Enhancer EGA	169
5th Generation	
Logical Connection 256K	429
Hercules	
Graphics Card Plus	179
Intel	
AboveBoard 2 Plus w/OK	319
AboveBoard PS/286 w/512K	419
AboveBoard Plus w/512K	429
AboveBoard Plus I/O 512K	579
Inboard 386/PC 80386 CPU	589
80287-8 IBM XT 8MHz CoP.	219
80387-16 16MHz 80386	399
Orchid Technology	
ProDesigner VGA	329
TinyTurbo 286	269
Renaissance	
RVGA2 800x600 256K-PAL	259
Video 7	
Vega VGA Adapter	279
FastWrite Video Adapter	319
V-RAM VGA Adapter	469

STORAGE DEVICES

American Power	
450AT + UPS Backup	439
Everex	
Floppy Stream 40 40MB Int.	359
Excel Stream 40T 40MB Int.	529
Miniscribe	
8425 20MB 3½" 40Msec	259

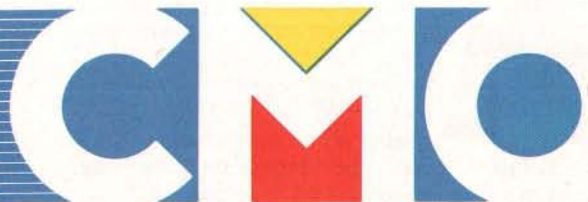

For Quality Computer Products.

3650 40MB 5 1/4" 61Msec	\$329
3053 44MB 5 1/4" 25Msec	469
6085 70MB 5 1/4" 28Msec	599
Mountain Computer	
TD-4340 40MB Int. Tape	319
TD-8000 80MB Ext. Tape	445



PLUS DEVELOPMENT
20MB HardCard
\$499

Seagate	
ST-225 20MB w/cont	249
ST-238 30MB w/cont	279
ST-251 40MB 1/2 height	349
Sysgen	
Bridge-File 5 1/2" External	249
Bridge-Tape 40MB External	479
SmartImage 60MB Internal	479
QIC-File 60MB External	599
Omni Board Controller	80

COMPUTERS

AST	
Bravo 80286 Model 5	879
Premium 286 Model 70	1299
Compaq	
Deskpro & Portable 286/386 Call	
IBM	
PS/2 Model 30 w/20MB	1599
NEC	
Multimate Laptops	Call
PC-TOO	
256K 12MHz 8088 Dsktp	449
512K 12MHz 80286 Desktop	899
Sysgen	
ProSystem 12MHz w/40MB	1999
Toshiba	
T1200 Floppy/HrdD Lptp	Call
Zenith	
80286/386 Desktops	Call
SuperSport & Superspt 286	Call

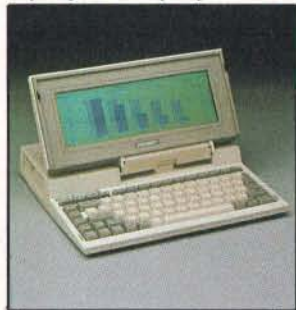

TOSHIBA
T1000 8088 Laptop
\$779

COMMUNICATIONS

Anchor	
6480 C64/128 1200 Bd.	100

520 ST520/1040 1200 Bd.	\$129
2400 Baud Lightning f/i	109
2400 Baud External	169

Atari	
XMM301 XL/XE 300 Baud	45
SX-212 ST Modem	90

Avatex	
1200 HC External	99

Everex	
Evercom 12 1200 Baud Int.	80
Evercm 24 2400 Internal	149
Evercm 24E+ 2400 Bd. Ext.	189

Hayes	
SmartModem 1200 Baud	289
SmartModem 2400 Baud	429

Intel	
2400EX External	299

Murata	
M1200 Facsimile	699

Panasonic	
UF-140 Panafax Facisimile	899
FX-89 Fax Board	699
FX-505 Hi-Res Scanner	1049

Practical Peripherals	
1200 Baud Internal	69
1200 Baud Stand Alone	85
2400 Baud Stand Alone	139
2400 Baud Internal	189



AVATECH
2400 Baud External
\$129

Sharp	
FO-220 Facsimile Machine	899
Supra	
2400AT 2400 Baud Atari	169
The Complete PC	
Complete FaxBoard 4800	269
Complete Answ. Machine	239
Complete Full-Page Scan.	579

PRINTERS

Alps	
ASP-1000 9-Pin Flatbed	159
Allegro 24 24-Pin Flatbed	319
Brother	
M-1709 240cps, 132 Col.	369
M1724L 24-Wire, 132 Col.	569
HR-20 20cps Daisywheel	329
HR-40 40cps Daisywheel	589

Epson	
LX-800 180cps, 132 Col.	169
FX-1050 264cps, 132 Col.	459
LQ-500 180cps, 24-Wire	279
LQ-850 330cps, 24-Wire	Call
LQ-950 264cps, 24-Wire	Call
LQ-1050 330cps, 132 Col.	Call

Hewlett-Packard	
2225 Thinkjet	329

NEC	
P2200 Pinwriter 24-Wire	359
P5200 Pinwriter 265cps	549

Okidata	
ML-182 + 180cps, 80 Col.	249



EPSON
FX-850 264cps,
80 Col. \$339

ML-320 300cps, 80 Col.	\$359
ML-390 270cps, 24-Wire	499

Panasonic	
KX-P1180 192cps, 80 Col.	185
KX-P1191 280cps, 80 Col.	249
KX-P1124 192cps, 24-Wire	349
KX-P1524 24-Wire, 132 Col.	559

Seikosha	
SP1600AI 160cps, 9-pin	185
SK3000AI 300cps, Color	365

Star Micronics	
NX-1000 144cps, 80 Col.	159
NX-1000 RainBow Color	229
NX-2400 24-Wire, 80 Col.	369

Toshiba	
ExpressWriter 311	New

PLOTTERS/DIGITIZERS

9012 HIPAD+ 12"x12" Tblt	399
PC695A 4-Pen A&B Plotter	599

Seiko	
DT-3503 11"x11" Digitizer	379

Summagraphics	
SummaSketch +12"x12"	399

MS-DOS SOFTWARE

Ashton-Tate dBase IV	459
----------------------	-----

Ashton-Tate MultiMate II	\$289
Bloc PopDrop	32
Bloc Form Tools	55
Borland Paradox R-Database	439
Borland Quattro	149
Central Point PC Tools	50
DAC EASY Accounting	60
Delrina Per FORM	159
5th Generation FastBack Plus	99
Fox Base + Development	199
IMSI OptiMous w/Dr. Halo III	79
IMSI Turbo CAD	59
Intuit Quicken	33
Logitech C7 Mouse w/Softw.	79
Lotitech ScanMan Scanner	189
Lotus Lotus 1-2-3	299
MECA Managing Your \$	119
Meridian CarbonCopy +	119
MicroPro Wordstar Pro 5.0	199
Microsoft Mouse	109
MSC OmniMouse	39
Nolo Press WillMaker	35
Peter Norton Adv. Utilities	80
Practiceer Accounting	169
Quarterdeck DESQView	80
Server Technology EasyLan	179
SPC 1st Choice 3.0	90
SPC 1st Publisher 2.0	80
SPC Professional Write 2.0	179
TOPS for DOS	119
Traveling Lap-Link +	85
WordPerfect 5.0	219
Xerox Ventura Publishing 2.0	459

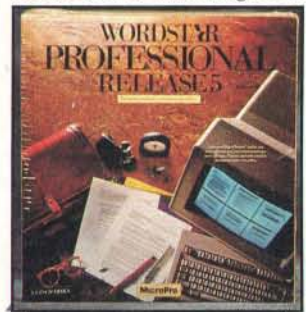

MICROPRO
Wordstar Pro 5.0
\$199



Your Source for Hardware, Software & Peripherals

In U.S.A.

800-233-8950

In Canada call: 800-233-8949

All Other Areas call: 717-327-9575 Fax call: 717-327-1217

Educational, Governmental and Corporate Organizations

Call toll-free: 1-800-221-4283

CMO, 101 Reighard Ave., Dept. A1, Williamsport, PA 17701

Over 400,000 SATISFIED CUSTOMERS • MAJOR CREDIT CARDS ACCEPTED

POLICY: Add 3% (minimum \$7.00) shipping and handling. Larger shipments may require additional charges. Personal and company checks require 3 weeks to clear. For faster delivery, use your credit card or send cashier's check or bank money order. Credit cards are not charged until we ship. Pennsylvania and Maryland residents add appropriate sales tax. All prices are U.S.A. prices and are subject to change. All items are subject to availability. Defective software will be replaced with the same item only. Hardware will be replaced or repaired at our discretion within the terms and limits of the manufacturer's warranty. We cannot guarantee compatibility. All sales are final and returned shipments are subject to a restocking fee. We are not responsible for typographic or photographic errors.

MMC
MICROCOMPUTER
MARKETING COUNCIL
of the Direct Marketing Association, Inc.

A106

DR DOS. THE CHOICE IS OBVIOUS, MORE OR LESS.

DR DOS

- Full DOS application support
- Large disk partitions - greater than 32 megabytes
- LIM 4.0 expanded memory support
- Graphical icon-based user interface
- Fully executable from ROM
- Quick and easy installation
- Password protection for files and directories
- Full screen text editor
- Multiple command line recall
- Built-in help for utilities
- Backed by the Digital Research commitment to quality service and support

THE OTHER DOS

- Full DOS application support
- Large disk partitions - greater than 32 megabytes (DOS 4 only)
- LIM 4.0 expanded memory support (DOS 4 only)
- Graphical character-based user interface (DOS 4 only)

You don't have to look too closely to see how DR DOS stacks up against the competition. With an added set of features and capabilities, DR DOS gives you proven capability *and* flexibility in a superior alternative for any system. Whether you use a hand-held computer, a laptop, a diskless workstation,



a portable or a powerful full-sized system with specialized applications, DR DOS gives you everything you need to make the right choice. Obviously.

For more information: Systems Integrators and OEMs call Digital Research at 800-443-4200.

 DIGITAL RESEARCH®

DR DOS™
THE BEST CHOICE.

Digital Research and the Digital Research logo are registered trademarks, and DR DOS is a trademark of Digital Research Inc. Copyright © 1989, Digital Research Inc. All rights reserved.

The Fastest 80386s Ever?

Preliminary tests suggest that ALR will continue to dominate the DOS performance arena

For the better part of a year, the top spot in our DOS benchmark tables has been held by an entry from a small company in southern California. Advanced Logic Research (ALR) has been our performance leader with its FlexCache 25386 tower system. But with a slew of faster 33-MHz 80386-based systems announced recently, the ALR system was sure to be surpassed. However, even though detailed tests have yet to be performed on all these new systems, it's a good bet that the new king of the mountain will be another

continued

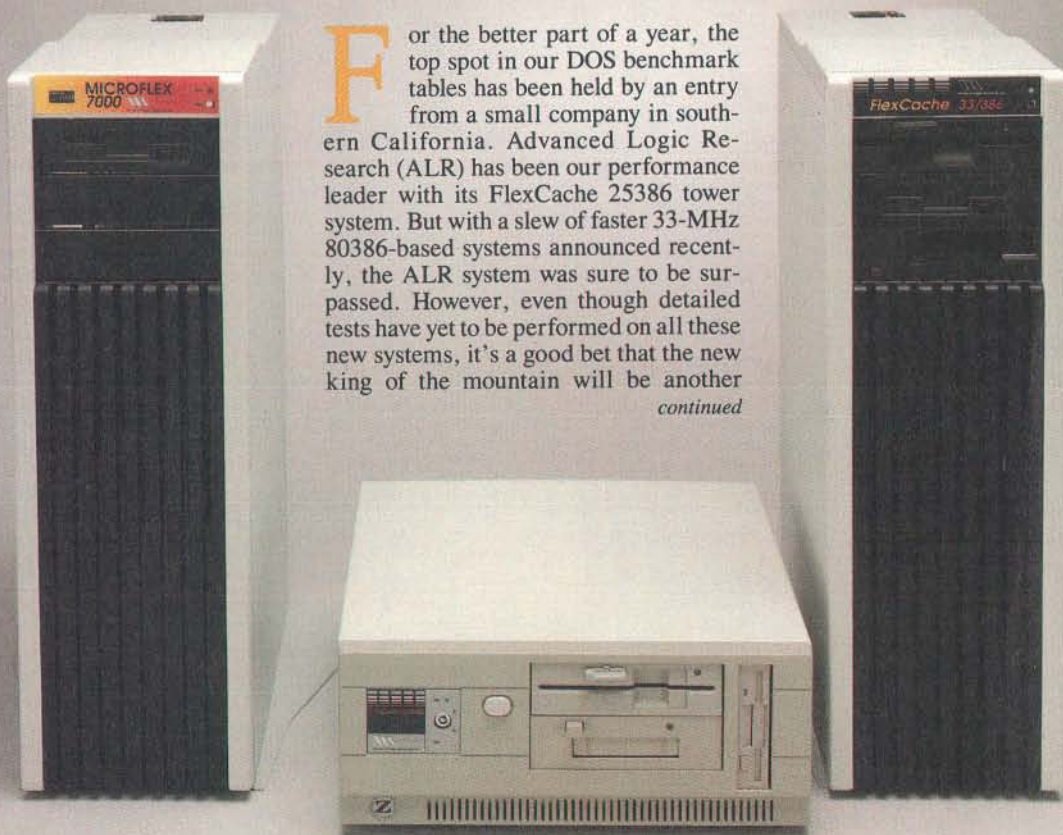

The ALR FlexCache 33/386 tower system (right) sports the fastest BYTE CPU index rating to date. The MicroFlex 7000 is at left, and the FlexCache 33/386Z is in the center.

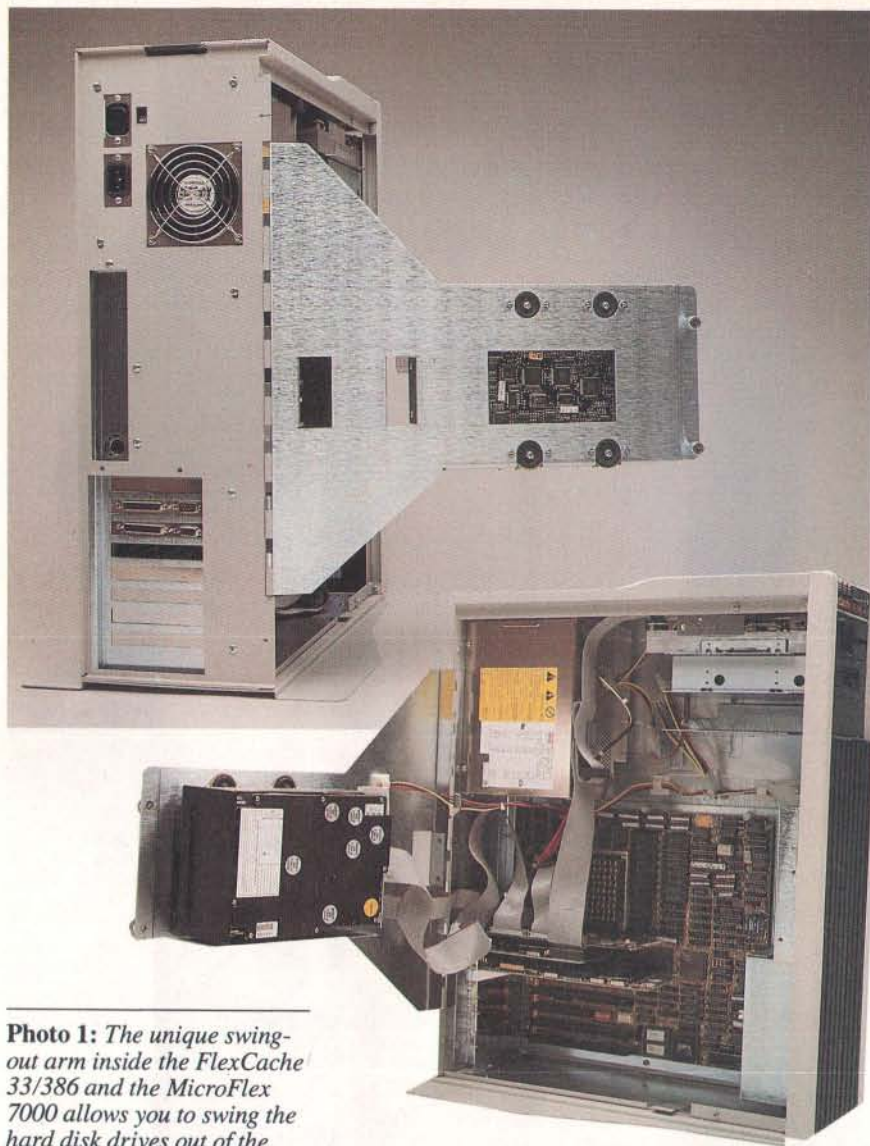

Photo 1: The unique swing-out arm inside the FlexCache 33/386 and the MicroFlex 7000 allows you to swing the hard disk drives out of the way to add extra memory or a math coprocessor.

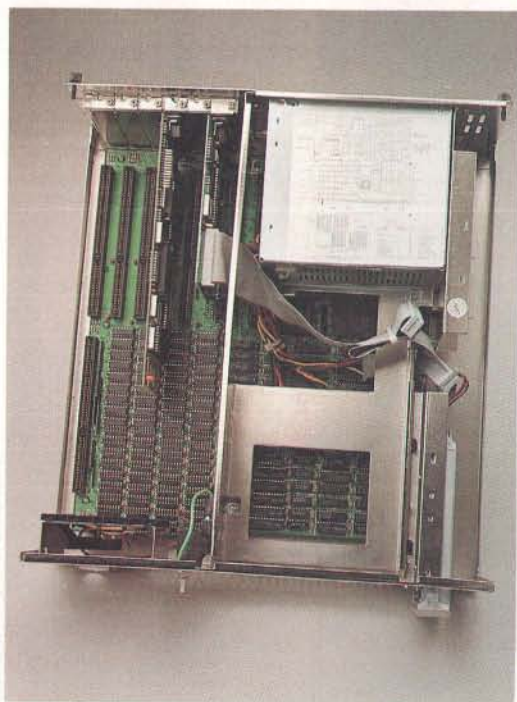

Photo 2: The ALR FlexCache 33/386Z has its 3 1/2-inch hard disk drive hidden in the rear right corner of the system.

ALR computer: the 33/386.

What is perhaps even more impressive is that the company appears to recognize that the computer world consists of more than just power users with deep pockets. ALR has also recently announced other systems that will probably each represent the fastest in its own category. The first of these is a compact \$4000 version of the 33-MHz system called the FlexCache 33/386Z. Next is the MicroFlex 7000, ALR's 25-MHz Micro Channel architecture (MCA) clone, which recently became available. Rounding out the list are two affordable systems based on the 80386SX: the FlexCache SX386Z and the diminutive VIP SX386, a machine that probably sets a new standard in the DOS world on a performance-per-cubic-inch basis.

For this article, I'll concentrate on the three most recent of these systems: the two 33-MHz systems and the 25-MHz MicroFlex 7000; each of these has some unique features. (For a look at the VIP SX386 and the SX386Z, see the text box "ALR's SX Machines.")

The Swing-Out Disk Drive

The high-end 33/386 looks like a standard desk-side tower system, such as the IBM PS/2 Models 60 and 80. The most distinguishing feature is ALR's traditional wide-finned black plastic grill. And unlike the IBM systems, it has room on the front for both the 3 1/2-inch floppy disk drive that comes standard with the system and a half-height 5 1/4-inch storage device, such as a floppy disk drive or tape drive.

Inside, however, the situation is different. To get inside, you loosen two thumbscrews that secure a tight-fitting metal cover designed to thwart the considerable radio-frequency interference given off by such a high-speed system. Under the cover is an innovative swing-out bracket that can hold two hard disk drives, one full-height 5 1/4-inch device and one 3 1/2-inch device (see photo 1).

With the drives swung out of the way, you have easy access to the motherboard. Installing an 80387 or extra single in-line memory modules (SIMMs) should be a snap. The disk drive we saw is also heavily shock-mounted. This is probably required for the swing-out arm mounting, but even if the user never takes advantage of this feature, the shock mounting should provide an extra level of reliability.

The system's motherboard is large and heavily populated. The most interesting part is the system's cache, which is a substantial 128K bytes, four times larger

than most other high-end systems. The cache is composed of fast 25-nanosecond static RAM, whereas the main system uses 60-ns DRAM.

For higher speed, ALR has chosen to use its own custom cache circuitry rather than the Intel 82385 cache-controller chip used on many other systems. In addition, the cache is connected to the main memory by a 64-bit-wide bus. Theoretically, this wide bus would require only half as much time as a 32-bit-wide bus on a cache "miss," when data must be moved from main memory to the cache.

ALR also uses an unusual design for its clock circuitry. At 33 MHz, each clock cycle lasts only 30 ns, appreciably less than the 40 ns available in a 25-MHz machine. To get the most out of those 30 ns, ALR has used fast emitter-coupled logic chips to generate the clock pulses. The ECLs are appreciably faster than the more common TTL circuits.

ALR's design appears to have paid off. Based on preliminary benchmark tests, the system easily outdistances all 25-MHz systems. Its CPU performance comes in with a score of 6.57, compared with the IBM PC AT's score of 1 and ALR's 25-MHz record holder's score of 5.07. This is only 30 percent faster than the 25-MHz system, less than the 32 percent you would expect from the increased clock speed alone. But the new ALR system is 56 percent faster than the Compaq 386/25. The only other 33-MHz systems we have tested are the Zenith Z-386/33 and the SIA 386/32; the latter uses a 25-MHz-rated CPU running at 33 MHz. The ALR 33/386 beats them both on the CPU index.

The new ALR tower system also has an attractive price: \$9990, which includes 2 megabytes of memory, a 16-bit VGA adapter, and a 150-megabyte ESDI hard disk drive.

Compact Power

The second 33-MHz system from ALR is the FlexCache 33/386Z, a small desktop system about the size of the Compaq 386/20s (see photo 3). ALR also claims it is within a half inch of the size of the IBM Model 50. The system has a standard appearance except for its floppy disk drives. It has two 5¼-inch half-height storage bays arranged horizontally and a 3½-inch floppy disk drive arranged in a peculiar vertical orientation. Although this vertical orientation makes effective use of the front panel real estate, it can be confusing at times: Do you insert a disk with the label to the left or to the right? Nine times out of 10, I inserted

continued

ALR's SX Machines



The low-priced ALR FlexCache SX386Z (right) and the petite VIP SX386. Both use an 80386SX processor and have very reasonable price tags.

So far, we have not been overly impressed with the selection of systems based on the 16-bit-wide 80386SX that we've seen. The systems seem to have combined mediocre 80386 performance with high prices. Two recent Advanced Logic Research systems buck that trend, however.

The ALR SX386Z is about the size and shape of the new 33/386Z desktop system. The VIP SX386 is about the size of an elongated lunch box. Both systems are compact, especially the VIP SX386 (see photo).

The area in which they are most impressive is in their price/performance ratios. Both systems use the Intel 82385 cache controller with a 16K-byte cache. ALR claims it has created custom cir-

cuitry to allow this controller to run on the 16-bit bus of the 80386SX. The circuitry seems to have paid off. In CPU performance, the VIP SX386 is about 2½ times the speed of an IBM PC AT. By comparison, the Compaq 386s system is not even twice as fast, with a score of only 1.86 (see table 1). Although we have not tested the VIP SX386 system, ALR says it has similar circuitry and performance.

Hand in hand with the impressive performance of these systems are their prices. Indeed, ALR claims it is offering them at the same price as its equivalent 80286 systems. With 1 megabyte of memory and a floppy disk drive, the SX386Z costs \$1795, while the smaller VIP SX386 sells for \$1895.

Table 1: Performance indexes. *The ALR systems seem to be very fast in CPU performance. The new 33/386 is over 6½ times faster than the IBM PC AT. The tests for the 33-MHz systems were performed on prototype systems; production systems should have slightly different values. ALR says it will soon modify the VGA circuitry to enhance video performance on all systems. All test data shows performance relative to an AT, where an AT's performance = 1.*

Machine	CPU	FPU	Disk	Video
80386SX				
ALR SX386Z	2.76	4.36	1.64	1.81
Compaq 386s	1.86	5.03	1.78	1.87
Twinhead Superset 490 ¹	1.93	5.91	1.45	1.17
MCA				
ALR MicroFlex 7000	4.96	7.87	2.34	2.95
Tandy 5000 MC	3.71	7.91	1.25	2.26
IBM PS/2 Model 70-A21	4.71	10.23	1.64	2.96
33 MHz				
ALR 33/386Z ¹	5.37	11.17	1.58	3.86
ALR 33/386 ¹	6.56	11.13	2.32	1.62
SIA 386/32 ²	5.99	14.20	2.36	3.06
Zenith Z-386/33 ¹	4.78	N/A	3.12	3.03
25 MHz				
ALR 25386	5.07	10.55	2.74	2.57
Compaq 386/25	4.22	10.37	2.55	3.38

¹ Prototype; performance of production units might vary.

² Uses a 25-MHz CPU running at 33 MHz.

For a full description of all the benchmarks, see "Introducing the New BYTE Benchmarks," June 1988 BYTE.

Rack & Desk PC/AT Chassis

Integrand's new Chassis/System is not another IBM mechanical and electrical clone. An entirely fresh packaging design approach has been taken using modular construction. At present, over 40 optional stock modules allow you to customize our standard chassis to nearly any requirement. Integrand offers high quality, advanced design hardware along with applications and technical support *all at prices competitive with imports*. Why settle for less?

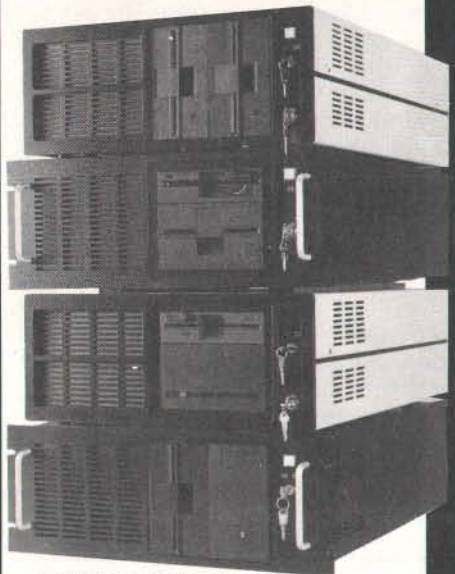

Rack & Desk Models

Accepts PC, XT, AT Motherboards
and Passive Backplanes

Doesn't Look Like IBM

Rugged, Modular Construction

Excellent Air Flow & Cooling

Optional Card Cage Fan

Designed to meet FCC

204 Watt Supply, UL Recognized

145W & 85W also available

Reasonably Priced

Now
Available

Passive
Backplanes



INTEGRAND

RESEARCH CORP.

Call or write for descriptive brochure and prices:
8620 Roosevelt Ave. • Visalia, CA 93291

209/651-1203

TELEX 5106012830 (INTEGRAND UD)

FAX 209/651-1353

We accept Bank Americard/VISA and MasterCard

IBM, PC, XT, AT trademarks of International Business Machines.
Drives and computer boards not included.

The new
FlexCache 33/386Z
is the fastest machine
for under \$5000.

it wrong. The front panel also has a white on/off toggle and a keylock that does not, unfortunately, lock the system case.

Inside is another innovative use of space. A 3½-inch hard disk drive is hidden back in the rear right corner of the case, next to the power supply.

The circuitry that the ALR 33/386Z uses is much more conservative than that found in its faster brother. The 386Z uses an Intel 82385 cache controller with a 32K-byte cache of 25-ns memory and a 32-bit bus.

The more conservative design results in more conservative performance. Its CPU performance score is 5.37—still impressive, but not much faster than ALR's 25-MHz system (5.07). The 386Z was, however, 27 percent faster than Compaq's 386/25.

While not the fastest DOS machine available, the new FlexCache 33/386Z is easily the fastest in the under-\$5000 class. The base system with 1 megabyte of memory but no hard disk drive or video card costs just \$3995. It seems to be an attractive compromise of power, price, and compactness.

Micro Channel Churner

Rounding out ALR's collection of high-performance systems is the recently introduced MicroFlex 7000. This system not only is one of the few machines compatible with the high-end IBM PS/2s, but will probably also be the fastest such machine for some time to come.

Externally, the system looks almost exactly like ALR's 33/386 tower system. Like the 33-MHz system, it has room for two 5¼-inch storage devices as well as the standard 3½-inch floppy disk drive.

One interesting part of the new system's exterior is a set of eight small LEDs. These tiny lights give an indication of how often the processor is accessing the system's cache. ALR says software developers can use the lights to optimize their software so that it makes the most use of the cache.

Inside, the similarity with the 33/386 continues. The MicroFlex 7000 even has the same unique swing-out arm holding

two disk drives. It also features the extra-wide 64-bit bus between the cache and main memory. The cache, however, is only half as large (64K bytes).

One big difference, of course, is the MCA slots. There are eight of them: Three are 32-bit, and five are 16-bit. To drive these slots, the system has an ample 200-watt power supply.

In terms of performance, the 7000 outperformed all other 25-MHz systems and all other MCA clones (see table 1), but it was slightly slower than ALR's 25386. The base system includes 2 megabytes of memory, a 120-megabyte hard disk drive, and a VGA adapter. The list price is \$9499. If you need an MCA design, the 7000 appears to offer unprecedented power and expansion options.

Like most of today's high-performance systems, the ALR systems come with disk-caching software—in this case, Multisoft's PC-Kwik. This software dramatically improved the speed of the ALR systems in our disk drive tests.

ALR is also working on increasing the speed of the video. The company plans to modify the BIOS of the systems so they will no longer be compatible with Hercules or AT&T 6300 graphics; thus, they will no longer be register-compatible with CGA graphics. Supporting these additional graphics modes—which are not supported on the VGA boards of either IBM or Compaq machines—is said to significantly slow down video performance. Removing this compatibility gives the user the power to increase the performance of a system at the small cost of losing a level of compatibility that is becoming increasingly unnecessary.

For even faster video, ALR will sell the complete PC-Kwik package for \$50. Included is a program that will significantly increase video speed.

Although new systems seem to appear monthly, and being the fastest can change overnight, ALR's 25386 has been dominant for some time. If things proceed as we think they might, new ALR systems will again dominate the upper reaches of the performance spectrum.

Many factors besides CPU speed determine the value of a system. Among them are reliability and overall performance. We hope to have more data on these aspects in an upcoming review of ALR's new machines, but for now, they seem to be a very attractive combination of price and performance. ■

Rich Malloy is associate managing editor of the news and technology section of BYTE and editor in chief of BYTEweek. He can be reached on BIX as "rmlloy."

SELECT 5 BOOKS for only \$4⁹⁵

(values to \$218.80)

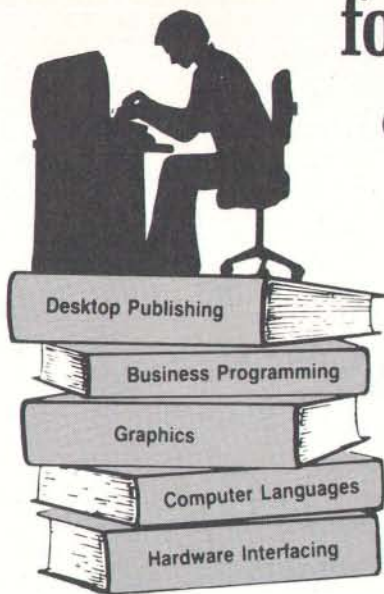

3116 \$27.95
Counts as 2

When it's new and important in business or personal computing,
The Computer Book Club® has the information you need . . .
at savings of up to 50% off publishers' prices!

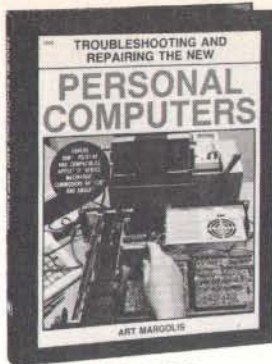

2809 \$27.95
Counts as 2

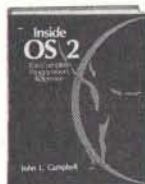

3019 \$39.95
Counts as 2



3146P \$17.95



1860P \$16.95



2997 \$25.95



2767P \$21.95



2852P \$17.95



2807P \$14.95



1848P \$16.95



2870 \$24.95



3047 \$34.95
Counts as 2



8226 \$29.95
Counts as 2



9808 \$34.95



9829 \$45.00



3109 \$28.95
Counts as 2



3128P \$22.95



9762P \$21.95



2831P \$14.95



2951P \$18.95



2913P \$14.95

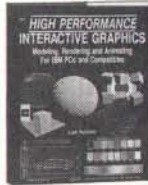

2879P \$22.95



3070P \$24.95
Counts as 2



2856P \$18.95



9785 \$86.95



2969 \$29.95
Counts as 2



3092P \$17.95



2929P \$15.95



3028 \$26.95
Counts as 2



3026 \$22.95



2890 \$34.95
Counts as 2



3030P \$17.95

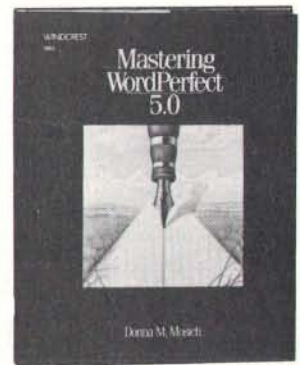

3084 \$29.95
Counts as 2

All books are hardcover unless numbers are followed by a "P" for paperback. (Publishers' Prices Shown)



The Computer Book Club®

Membership Benefits • Big Savings. In addition to this introductory offer, you keep saving substantially with members' prices of up to 50% off the publishers' prices. • **Bonus Books.** Starting immediately, you will be eligible for our Bonus Book Plan, with savings of up to 80% off publishers' prices. • **Club News Bulletins.** 14 times per year you will receive the Book Club News, describing all the current selections—mains, alternates, extras—plus bonus offers and special sales, with scores of titles to choose from. • **Automatic Order.** If you want the Main Selection, do nothing and it will be sent to you automatically. If you prefer another selection, or no book at all, simply indicate your choice on the reply form provided. As a member, you agree to purchase at least 3 books within the next 2 years and may resign at any time thereafter. • **Ironclad No-Risk Guarantee.** If not satisfied with your books, return them within 10 days without obligation! • **Exceptional Quality.** All books are quality publishers' editions especially selected by our Editorial Board. BY689

If card is missing, use this address to join: ©1989 THE COMPUTER BOOK CLUB®
Blue Ridge Summit, PA 17294-0820

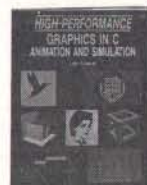

3049P \$26.95
Counts as 2



2620 \$25.95



3035P \$14.95



3057P \$15.95



2850 \$25.95



8229P \$19.95

Greased Lightning

Zenith's 33-MHz Z-386/33 paves the way for EISA

Several vendors have pushed Intel's 25-MHz 80386 chip past its rated limits using special cooling techniques. Zenith's new unit—the first that BYTE has seen with an Intel 33-MHz chip—doesn't resort to such measures. The Z-386/33 is a true 33-MHz system. It is also an interesting preview of what next year's Extended Industry Standard Architecture (EISA) machines might look like. Zenith, one of the infamous "Gang of Nine," has extended the industry-standard AT bus in a way that should adapt cleanly to the forthcoming EISA standard.

The prototype system I evaluated came with 4 megabytes of RAM, a 320-megabyte ESDI-controlled hard disk drive, a 200-watt power supply, a serial/parallel board, Zenith's Z-549 VGA card, a single 1.44-megabyte 3½-inch floppy disk drive, and a Zenith 101-key keyboard. No 33-MHz 80387 coprocessors were available yet. When Intel produces 33-MHz coprocessors, Zenith expects to ship the Z-386/33 in a variety of configurations. A system like the one I reviewed will list for about \$15,000 and will include Zenith's DOS 3.3 Plus and Windows/386.

A Bridge to EISA

Like its 25-MHz cousin, the motherboard provides four 32-bit SuperSet slots and three standard AT slots. Each slot

can accept an 8- or 16-bit board and can run at 8 MHz. The SuperSet slots use an additional connector that, when activated, can boost bandwidth to 32 bits and speed to 33 MHz.

My review system came with a single SuperSet board. It's the I/O board, but Zenith has also placed on it the ROM BIOS, CMOS RAM, and, most interestingly, some bus-control circuitry. The board controls a dual AT/SuperSet bus now, but Zenith expects to eventually build a variant that will control an EISA bus. By separating the I/O subsystem from the memory/CPU subsystem in this way, Zenith simplifies the expected transition to EISA.

What else can you do with SuperSet slots? Well, for now, the same thing you can do with Micro Channel slots—add memory-expansion boards. The eight single in-line memory module (SIMM) sockets on the motherboard can accommodate a total of 32 megabytes of 32-bit RAM. With SuperSet expansion boards, you can boost total RAM to 64 megabytes. That's not an 80386 limit, of course, since the chip can address 4 gigabytes of memory. In order to conserve motherboard real estate and simplify the design, Zenith drew the line at 64 megabytes—a sizable playground for DOS, OS/2, Xenix, and Unix applications.

Of course, SuperSet slots also suggest some other possibilities. A 32-bit disk controller board, for example, could work well in a high-performance file server. In fact, Zenith halted the development of such a board—not because it wasn't a good idea, but because the company expects to bring it to completion under EISA.

Fine-Tuning

To keep pace with the 33-MHz microprocessor, the system buffers its relatively slow 100-nanosecond system DRAM with a 16K-byte, 15-ns static RAM cache. That doesn't sound like a large cache; comparable systems, like the SIA 386/32 (April BYTE), have used a 64K-byte cache. But Zenith's engineers say they've demonstrated that the core instructions for today's operating systems and applications fit into the smaller cache and that a larger one yields no substantial benefits.

In any case, cache memory resides on its own card (see photo 1), and you'll be able to upgrade it. A 16-level write-back queue augments the memory-caching scheme. The system writes to a queue that can hold 16 doublewords, and it updates memory on demand for altered data or when extra CPU cycles permit.

When I ran the BYTE system benchmarks, the Z-386/33's CPU index fell short of the number BYTE reported in April for the SIA 386/32 (see table 1). That's mostly a function of the String Move tests, though. These tests defeat the caching scheme and force systems to fall back on their slower system RAM, and the Zenith machine's 100-ns DRAM chips are slower than the SIA machine's 70-ns chips. However, the remaining CPU tests—Matrix, Sieve, and Sort—don't subvert the caching scheme, and here the Z-386/33 outperformed the SIA 386/32.

A very fast Control Data Corp. hard disk drive (with a 14-millisecond rated access time), coupled with a Zenith-modified ESDI controller, makes for a formidable disk subsystem. Under Ze-

continued

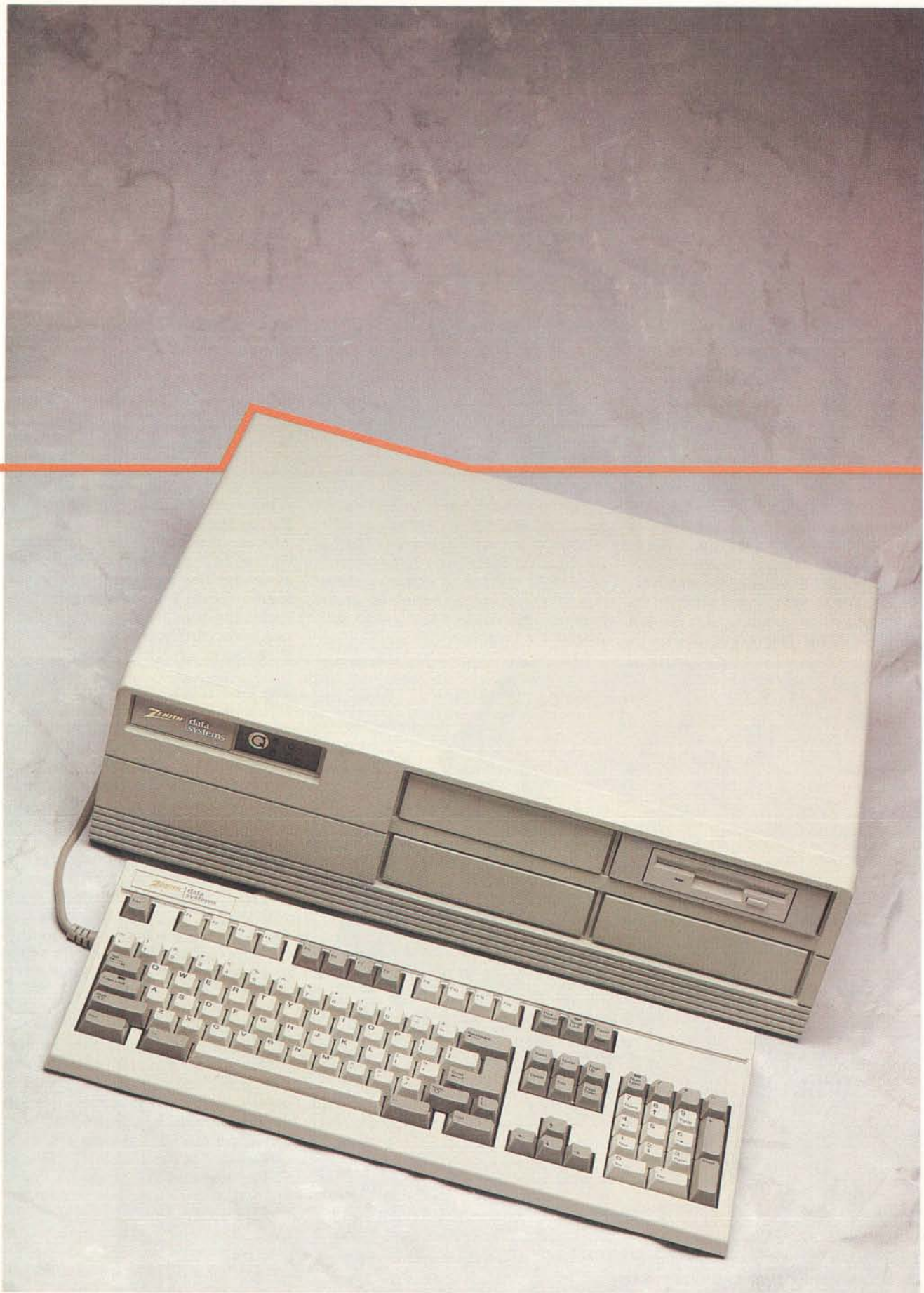

Table 1: Benchmark results of a comparison of the Zenith Z-386/33 and the SIA 386/32. For indexes only, higher numbers reflect better performance.

CPU	Zenith	SIA	DISK I/O	Zenith	SIA	VIDEO	Zenith	SIA
Matrix	2.02	2.10	Hard Seek¹			Text		
String Move			Outer track	3.33	3.33	Text average	3.45	3.21
Byte-wide	28.98	15.54	Inner track	3.33	3.31	Graphics		
Word-wide:			Half platter	4.98	6.65	Graphics average	1.87	1.96
Odd-bnd.	21.77	17.78	Full platter	8.35	9.10			
Even-bnd.	14.50	7.78	Average	4.98	5.60	Index:	3.03	3.06
Doubleword-wide:			DOS Seek					
Odd-bnd.	14.50	13.14	1-sector	4.43	10.23			
Even-bnd.	7.25	3.87	32-sector	13.80	18.77			
Sieve	10.45	11.02	File I/O²					
Sort	8.18	8.26	Seek	.02	.04			
			Read	.79	.85			
			Write	.65	.76			
Index:	4.78	5.99	1-megabyte					
			Write	2.75	2.89			
			Read	4.23	4.28			
			Index:	3.12	2.36			

Note: All times are in seconds. Figures are generated using the 8088/8086 and 80386 versions (1.1) of Small-C. For a full description of the benchmarks, see "Introducing the New BYTE Benchmarks," June 1988 BYTE.

¹ Times reported by the Hard Seek and DOS Seek are for multiple seek operations (number of seeks performed currently set to 100).

² Read and write times for File I/O are in seconds per 64K bytes.

nith's DOS 3.3 Plus (which, like DOS 4.0, eliminates the 32-megabyte limit on the size of a disk volume), the primary DOS partition spanned the entire 320-megabyte hard disk drive. To standardize my comparison, I reformatted the disk and installed a vanilla DOS 3.3 in a 32-megabyte partition.

The benchmark times for disk operations were spectacular. According to Zenith, the disk controller employs a pair of 1-sector (512-byte) *swing buffers* that operate in an interleaved manner to boost disk I/O bandwidth. According to the numbers, this strategy works very well, indeed.

However, Zenith again fell short of SIA on the Video index. The company attributes that result to the Z-549's register-level EGA compatibility. The built-in mode-checking required to support that feature incurs a performance penalty. Zenith indicated that the Z-386/33 may ship with a different VGA—a version of Video Seven's FastWrite.

The Fast Track

I could try to coin some speedy terminology appropriate to the new 33-MHz plateau, but I won't. From one perspective, the Z-386/33 is merely faster than most (if not all) 80386 systems available today. The reasons for this are obvious: the genuine 33-MHz CPU clock rate and the panoply of sophisticated subsystems that support operation at that frequency.

This is the first true 33-MHz machine I've seen, but others will appear as the year progresses. And, in keeping with the industry's tendency to be quick to reach for the next plateau, Zenith's engineers told me they've already pushed the 33-MHz chip to 40 MHz in a freon-cooled environment.

From another perspective, though, the architecture of this machine demonstrates Zenith's commitment to build EISA machines and parts at the earliest opportunity. Will that render the Z-386/33 obsolete? Not likely. Most users care about operating systems and applications, not bus architectures. Here's a 32-bit-extensible, AT-compatible system that will deliver excellent performance running DOS, extended DOS, Unix, or OS/2. ■

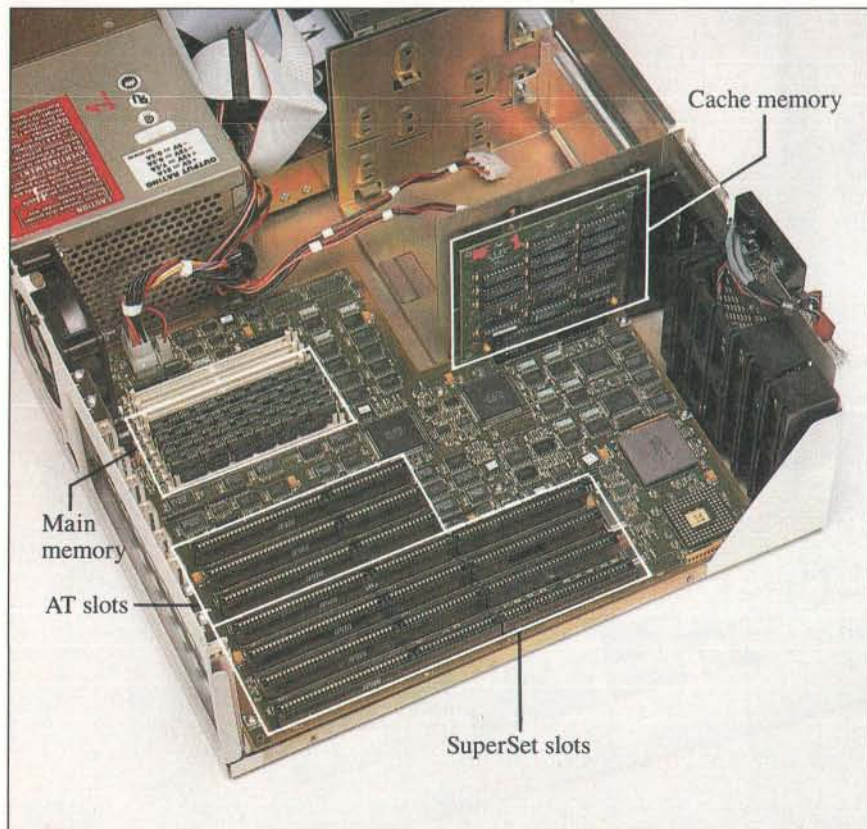

Photo 1: The Z-386/33 motherboard. SIMM-mounted system RAM and a half-length cache board make memory upgrades a snap.

Jon Udell is a BYTE technical editor. He can be reached on BIX as "judell."

Maxon MVGA-16 adapter works with flying colors



**providing VGA[®]
compatibility equal
to IBM's own VGA adapter**

That's right . . . Maxon's MVGA-16 adapter is 100% IBM[®] compatible. So, if you're using one of the standard IBM modes (up to 640x480 with 16 colors), you don't need a special driver at all.

When extended resolution* is required, Maxon still comes through with flying colors. The MVGA-16 includes drivers for AutoCAD[®] - ADI[®] versions 2.1 and 3.1, Lotus[®] 1-2-3[®] - release 2.x, Framework II[®] - releases 1.0 and 1.1, GEM[®] Desktop[™] - version 2.x, Ventura Publisher[®] - releases 1.1 and 2.0, MS[®] Windows[®]/286 - versions 2.03 and 2.1, WordPerfect[®] - releases 4.0 and above, and WordStar[®] - release 3.xx. And that's not the whole story . . . additional drivers are being added constantly.

Circle 166 on Reader Service Card

*High-res drivers offer different resolutions for different software packages.

**with features
that make it
unequaled by any
other VGA adapter**

- Operates up to 400% faster than IBM VGA adapter
- Extended modes (require 512K of RAM): 1024x768 - 16 colors; 640x480 - 256 colors
- Full BIOS and REGISTER compatibility with MDA[®], CGA[®], MCGA[®], EGA[®], VGA[®] and Hercules[®]
- Works with either XT[™] or AT[®]: 16 bit design - auto-detects and adapts to 8 bit slots
- High-res drivers for popular software

**For more information about Maxon's
16 bit VGA adapter, phone (415) 377-0269,
FAX (415) 377-0236 or write to Maxon Systems, Inc.,
One Waters Park Drive, Ste. 117, San Mateo, CA 94403.**

maxon[®]
SYSTEMS INCORPORATED

A Wholly Owned Subsidiary of Maxon Electronics Co. Ltd. of Korea

The following are tradenames or registered tradenames of the companies listed: IBM, XT, AT, VGA, MDA, CGA, MCGA and EGA - International Business Machines Corp.; Hercules - Hercules Computer Technology, Inc.; MVGA-16 - Maxon Systems, Inc.; AutoCAD and ADI - Autodesk, Inc.; Lotus and 1-2-3 - Lotus Development Corp.; Framework II - Ashton-Tate Corp.; GEM and Desktop - Digital Research Inc.; Ventura Publisher - Ventura Software, Inc.; MS and Windows - Microsoft Corp.; WordPerfect - WordPerfect Corp.; and WordStar - MicroPro Int'l. Corp.

© 1989 - Maxon Systems, Incorporated

The Only Character Recognition System

That Outperforms Ours

Nature's character recognition system can be trained to read any language. Flagstaff Engineering's **SPOT OCR Text Reader** is also trainable. It has read text printed in thousands of typefaces in over 130 different languages!

The SPOT OCR Text Reader works just like a typist who reads a page, then uses a keyboard to transfer the information on the page into a computer file—except SPOT uses a scanner for eyes and outputs the text directly into standard text files. SPOT is also faster. It can read up to 35 characters per second on a 16MHz AT, and up to 65 characters per second on a 25MHz machine (that's 780 words per minute). SPOT supports most major makes of scanners.

Using sophisticated statistical techniques, SPOT recognizes characters like the brain does: by examining their shape and context. Like nature's original, SPOT is very flexible. It can glance over an entire page or zoom in on a few lines of text. SPOT can read newspapers,

magazines, books, manuals, invoices, contracts, government documents, columns, tables . . . just about any printed text. And SPOT keeps getting better. The **new Version 3.0** is faster, more accurate, easier to use, and better documented than its predecessors.

Since 1982, Flagstaff Engineering has provided visionary data conversion solutions for thousands of companies worldwide. SPOT is already increasing productivity and making life easier for many publishers and researchers, accountants and telemarketers, medical and legal offices, archival and transcription services.

Wouldn't *your* business benefit from fast, accurate, and low-cost OCR software? Give us a call and let our application specialists explain how you can save time and money with SPOT, *the* OCR text-entry solution.



Helping People Read a World of Information

1120 Kaibab Lane • Flagstaff, AZ 86001
602-779-3341 • FAX 602-779-5998



Join Flagstaff Engineering's
BIX conference: flageng

Circle 96 on Reader Service Card for
S.P.O.T. 3.0 Version
97 for 9 Track Tape
98 for Disk Conversion Systems Up-Date
99 for DEALERS only



THE HUNT FOR BAD SECTORS

Like searching for an elusive enemy submarine, Jerry goes after bad sectors on his hard disk drive

This is a first: I'm starting this column one day after turning in the last one. Generally, when I end a column, I list some of the things I intend to write about the next month; but interesting new stuff comes in, I go to shows and see something hot, and even forget what I was interested in. My ready-line pile gets so large that I have to reshuffle. Out comes the next month's column, and half of what I promised isn't there.

This time it's different. The ready line is intact from last month's column, and I haven't been to any new shows.

But First...

I did have one problem. As I mentioned last month, we installed Distributed Processing Technology's new superfast PM3011/70 Caching Disk Controller for ESDI drives. The PM3011/70 runs in Big Cheetah and controls the Priam 330-megabyte hard disk drive. I am now convinced that this may be the best combination of disk drive and controller in the microcomputer world.

I have thrashed this system something awful, what with reformatting the hard disk drive, moving data across logical drives, and moving data to and from the Maximum Storage WORM (write once, read many times) drive. And when I say moving data, I mean a *lot* of data, 25 to 30 megabytes and 845 files in one XCOPY move with the /v option on, followed by verifying the files against the copies in the WORM drive. I ran that in a repeating batch file for hours. Not one

glitch, hesitation, retry error, or lost bit; it all works.

Of course, I not only expect but demand reliability. I'm a firm believer in Bill Godbout's old maxim (now shamelessly promoted to one of Pournelle's laws), "If the error rate is high enough to measure, it's too high." Reliability I expect; what's different about the combination of the PM3011/70 and the Priam drive is that it is *fast*.

Indeed, it's fast enough that I began to get obsessed with documenting just how fast. I have a disk-speed-evaluation program from CORE International, Coretest, which measures seek times and data transfer rates. It combines this all into a single figure, the *performance index*; and after I got the PM3011/70 installed, I ran around trying it on my machines. Some relevant performance indexes: Kaypro 386i (2.8), AT&T PC 6300 Plus (3.25), IBM PC XT clone, courtesy of Larry Aldridge (3.81), generic AT 80286 (4.6), Zenith Z-386 with a Smart-drive cache (15.14), and Cheetah 386 with the PM3011/70 (48.50).

That's one set of test runs. I could accumulate others: I have other machines, there are two different versions of Coretest, and you never get the same answer twice anyway. The Cheetah figure goes from as low as 44 to as high as 52, and the Z-386 has once hit 16.8; but this should give you an idea.

Incidentally, this is all single-user, single-task data. The neat part about the Cheetah/PM3011/70 combination is that the PM3011/70 has its own cache memory (and thus doesn't take up system extended memory for a disk cache); and it will serve more than one user or task without measurable loss of performance.

The Problem

You'll notice in the above that I do not have a figure for the Z-386 without a cache. There's a story behind that.

When I first tried Coretest on the Z-386, I got the notice "Read error on drive

0." This was reported consistently. Alas, Coretest doesn't give you any clue as to where the read error happened; it just says there is one.

This was annoying. I knew of two bad sectors on the Z-386's hard disk drive, but they had been marked before I ever got the system. I'd never had the slightest indication that there were any problems with the drive.

Still, maybe it was time to go hunting. The first thing I tried was Golden Bow's Vmarkbad, which is part of Vopt. This program runs very fast, and when I had some problems with the Priam hard disk drive a couple of months ago, it rapidly found several bad sectors in logical drive E, marked them bad, and got on with the job. I still use Vopt to rearrange my hard disk files; I've been using software from Golden Bow for well over a year now and have never had any reason to regret it.

Vmarkbad reported no bad sectors. "All right," thought I. "Time for more heavy-duty software; stuff that runs longer."

The next thing I tried was the new Norton Disk Doctor, which comes with the Norton Utilities 4.5 Advanced. This program looks for scrambled boot records, bollixed file allocation tables, and other such problems. It then examines your drive, sector by sector.

Norton Disk Doctor reported no bad sectors. Coretest continued to report read errors.

Next was Mace Utilities Gold. Paul Mace has done a good book (*The Paul Mace Guide to Data Recovery*, Brady Computer Books, 1988) on the subject, and I had just received a new copy of Mace Utilities Gold, which attempts to rival Norton Utilities. Either will do a good job, and competition drives both of them to add new features.

The new Mace Recovery program examines sectors in much the same way (and with much the same visual display)

continued

as Norton Disk Doctor. Mace Recovery runs a bit faster than Norton Disk Doctor. I can't tell you which is the more thorough; Mace Recovery didn't find anything wrong with that drive.

Coretest continued to report a read error. I tried Coretest on all my other machines. It never found any read errors except on the Z-386.

Now I was getting angry. Time for Steve Gibson's SpinRite, which said it could improve my drive performance by changing the interleave factor on the Z-386's hard disk drive. I told it to go ahead. Then it did what it called an "extremely thorough analysis" of the drive. That took all night, and it didn't find anything.

Neither did Disk Technician Plus. Next up to bat was Kolod Research's HTest/HFormat, which is famous for its thoroughness. Indeed, Paul Mace is supposed to have bought the programs to bundle with his utilities. Mace Utilities Gold comes on five disks, but HTest/HFormat isn't on them; I guess you have to get it separately. HTest/HFormat is nondestructive and runs all night. It didn't find anything.

By now I was getting *really* angry. I decided to back up everything to the Maximum Storage WORM drive (I have several WORM controllers and carry the external WORM drive from machine to machine as needed) and then use HTest/HFormat on the drive. *That* ought to solve the problem.

Bugs in XCOPY

In doing the backup, I found a terrible bug in the XCOPY that's distributed with Zenith DOS 3.21. This XCOPY.EXE is 5402 bytes long; my version is dated 5-01-87, and it is *unreliable*. This is the version of DOS that was distributed with all Zenith Z-248 machines to the armed

forces, including the service academies, and is still widely used. It also came with my Z-386 and with the SupersPort 286 laptop.

The 5402-byte XCOPY will report that it has copied all files and subdirectories when it *has not done so*. The worst part is that if you don't have too many files and subdirectories—alas, I do not know how many is "too many"—it will work; it's when you use it for large numbers of files that it gets confused.

I found this by accident: I backed up all the files from the Z-386's hard disk drive, and for some reason I decided to look on the WORM drive to be sure they were there. I found a number of empty subdirectories. The subdirectories had been created, but nothing had been copied into them. I had to invoke Norton Commander and go through and copy each subdirectory manually. That took most of an afternoon.

It was then that I decided to install a new version of DOS. I had to: XCOPY is version-sensitive, and simply adding a new version of XCOPY without changing DOS 3.21 won't work.

Media Analysis

I used HTest/HFormat on the drive, then installed DOS 4.01. This took a while: and when it was done, to my horror, I found that DOS 4.01 could not find the WORM drive. This may be a problem with the Maximum Storage software: when DOS 4.01 came out, the Norton Utilities wouldn't work with it. But for whatever reason, I couldn't access the WORM drive under DOS 4.01, and that was far too high a price to pay for the latest DOS.

I started over once more, reformatting the hard disk drive yet again and installing DOS 3.3. By now, I had what very well may have been the best-formatted

hard disk drive in the world.

Coretest continued to report a read error.

"Drastic measures," I decided, and got out Storage Dimensions' SpeedStor, which is a set of disk format and test utilities that I've used for some time now. SpeedStor allows you to have drive partitions larger than 32 megabytes if you're so inclined. More to the point, SpeedStor has a series of diagnostics, beginning with a very thorough nondestructive read test, and ending with the Media Analysis test that is guaranteed to wipe out any files on your hard disk drive.

I selected Media Analysis. Once again, it ran all night. Come morning, SpeedStor had found five sectors it didn't like and had locked them out.

Even better, Coretest reported no drive errors, and I was able to get a performance index figure of 4.54 for the Z-386's hard disk drive with no caching. I then let SpeedStor format the disk and installed DOS 3.3. So far, everything works fine.

The moral of this story is that Coretest seems to be as sensitive a test of read errors as any I have, and if you really want your drive to be reliable, back up your data and run SpeedStor's Media Analysis.

The Last Word

Having done all that, Coretest once again reports "Read error on drive 0" if I delete SMARTDRIVE.SYS from the CONFIG.SYS file. Nothing, including Media Analysis, can find an error, and I certainly have had no errors in normal operation.

Does Coretest know something, or is it just unable to work with a Z-386 that is equipped with the PM3011/70 controller? Tune in next month.

continued

A MESSAGE TO OUR SUBSCRIBERS

FROM TIME TO TIME WE MAKE THE BYTE subscriber list available to other companies who wish to send our subscribers material about their products. We take great care to screen these companies, choosing only those who are reputable, and whose products, services, or information we feel would be of interest to you. Direct mail is an efficient medium for presenting the latest personal computer goods and services to our subscribers.

Many BYTE subscribers appreciate this controlled use of our

mailing list, and look forward to finding information of interest to them in the mail. Used are our subscribers' names and addresses only (no other information we may have is ever given).

While we believe the distribution of this information is of benefit to our subscribers, we firmly respect the wishes of any subscriber who does not want to receive such promotional literature. Should you wish to restrict the use of your name, simply send your request to the following address.

BYTE MAGAZINE

ATTN: SUBSCRIBER SERVICE
P.O. Box 555
HIGHTSTOWN, NJ 08520



THE NEW STANDARD FOR HIGH PERFORMANCE STATISTICAL SOFTWARE

CSS

**COMPLETE STATISTICAL SYSTEM
WITH DATA BASE MANAGEMENT
AND GRAPHICS**

A powerful, comprehensive, elegant, and super-fast statistical package for IBM (PC, AT, PS/2) and compatible computers. ■ The CSS optimized user interface with fast hierarchical menus incorporates elements of artificial intelligence; even complex analyses require only a few keystrokes (batch processing is also supported). ■ CSS features comprehensive, state of the art implementations of: *Basic statistics, Multi-way frequency tables, Nonparametric statistics, Exploratory data analysis with analytic graphs, Multiple regression methods, Time series analysis with modeling and forecasting (incl. full ARIMA), General ANOVA/ANCOVA/MANOVA, Contrast analysis, Discriminant function analysis, Factor analysis, Principal components, Multidimensional scaling, Item analysis/Reliability, Log-linear analysis, Cluster analysis, Non-linear estimation, Logit/Probit analysis, Canonical analysis, Survival and Failure Time analysis (Censored data), Quality Control analysis, and much more.* ■ All statistical procedures are integrated with fast data base management and instant, presentation quality graphics (over 100 types); full support for all mono and color graphics boards (incl. VGA) and over 100 plotters and printers (incl. the HP and Postscript standards). ■ All CSS screen output is displayed via customized Scrollsheets™ (i.e., dynamic, user controlled, multi-layered tables with cells expandable into pop-up windows); all numbers in a Scrollsheet™ can be instantly converted into a variety of presentation quality graphs; contents of different Scrollsheets™ can be instantly aggregated, combined, compared, plotted, printed, or saved. ■ The flexibility of the CSS input/output is practically unlimited: CSS offers an intelligent interface (read/write) to all common file formats (Lotus, Symphony, dBIl, dBIll+, DIF, SYLK, ...) and special utilities to easily access data from incompatible programs; graphics can be saved in files compatible with desktop publishing programs (Aldus, Ventura). ■ CSS data files can be as large as your operating system (DOS) allows; OS/2 version coming soon. ■ CSS precision exceeds the standards of all common precision benchmarks. ■ *Technical note: The CSS user interface and all I/O were written in Assembler and bypass DOS; graphics and data management were written in Assembler and C; the computational algorithms were written in Assembler and optimized Fortran.* ■ \$495 (plus \$5 sh/h); 14-day money back guarantee.

Circle 259 on Reader Service Card



StatSoft

2325 East 13th Street ■ Tulsa, OK 74104 ■ (918) 583-4149

Fax: (918) 583-4376

Overseas Offices: StatSoft of Europe (Hamburg, FRG), ph: 040/4200347, StatSoft UK (London, UK), ph: 0438/310056 or 316561, StatSoft Pacific (Melbourne, Australia), ph: 613-663-6580
Available From: CORPORATE SOFTWARE and other Authorized Representatives Worldwide: Benelux: Lemax BV 02968-94210; France: Concoctel 45669700; Sweden: AkademiData 696201;

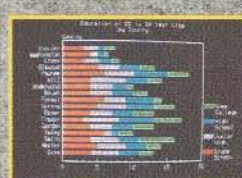
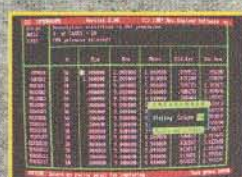
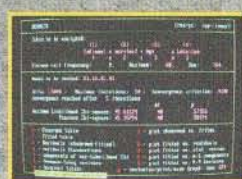
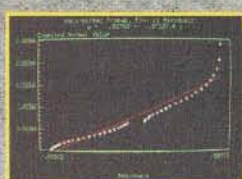
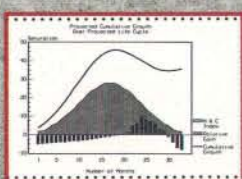
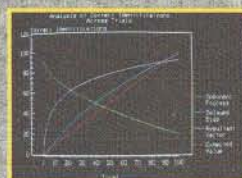
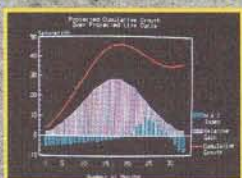
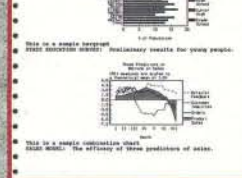
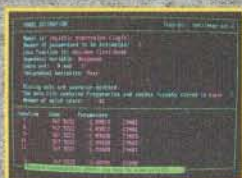
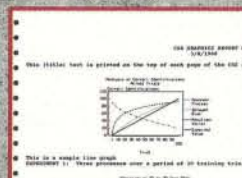
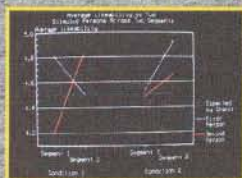
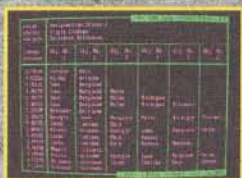
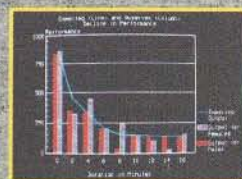
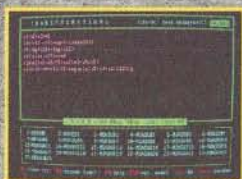
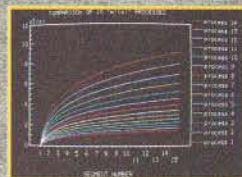
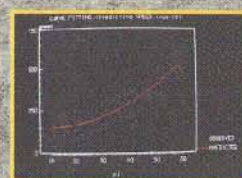
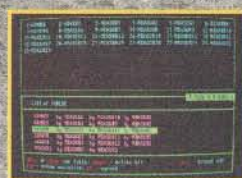
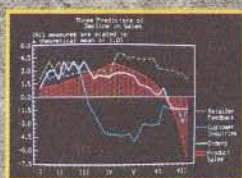

THE PROGRAMMER'S SHOP

helps save time, money, and cut frustrations. Compare, evaluate, and find products.

FREE!

Summer '89 Catalog
75+ New Products. Revised expanded descriptions make product selection even easier.
Mention "BY689"

Assemblers

	List	Ours
MS Macro Asm	150	109
Turbo Assembler/Debugger	150	115
Visible Computer 80286	100	89

C Language - Compilers

AZTEC C86 - Commercial	499	Call
High C-286 - by MetaWare	595	559
Instant C/16M	795	719
Lattice C - V3.4	450	289
Microsoft C 5.1 - w/CodeView	450	299
Microsoft QuickC 2.0	99	75
Turbo C - by Borland	150	115
Turbo C Professional	250	179
Watcom C6.5 - highly optimized	295	Call

Dbase & Tools

Buzzwords Toolboxes	295	269
CLEAR+ for dBASE	200	159
Clipper Summer '87	695	469
dBASE IV	795	Call
Dbase Online - 6 pop-up references	99	89
dBMAN V	190	179
dBRIEF w/BRIEF	275	179
dBug - source debugger	195	179
dBX - dBASE III to C	550	529
DBXL Interpreter	199	149
Documentor	295	239
FoxBASE+ - V2.1	395	259
Genifer - code generator	395	249
QuickSilver Diamond	599	369
R&R Relational Report Writer	149	119
Scrimmage by IDL - screen/menu	149	119
SoftCode w/dBASE templates	80	69
UI Programmer	295	239

New Discovery

C...Talk/Views

by CNS, Inc. Object-oriented C development environment for MS Windows. Includes 40+ object classes with source code. Build software objects, convert objects to C source. Includes C...Talk Automatic Make. Produces dynamically bound object messaging and optional static binding. No royalties. Call

Debuggers/Disassemblers

	List	Ours
Periscope II - breakout switch	175	139
Periscope III - 10 MHz version	1395	1259
SoftProbe II TX - debug	395	345
Sourcer	100	89

Editors

BRIEF	195	Call
COMPEDITOR	175	165
Edix	195	159
Epsilon - like EMACS	195	169
KEDIT - like XEDIT, V.4	150	125
Personal Rexx	150	129
MKS VI	149	129
PI Editor	195	Call
SPF/PC - V2.0	245	185
Vedit Plus	185	129

Text Screen Addons

AE Windows	225	139
C-scape	399	379
C Windows Toolkit	100	95
C Worthy w/forms	295	Call
Curses - by Aspen Scientific	159	109
with source	349	279
Greenleaf DataWindows	295	219
JAM by JYAC	750	679
Vitamin C - source, menus	225	169
Vermont Views - replaces WFD	395	Call
with source	790	Call

Note: Mention this ad. Some prices are specials. Ask about COD and POS. Formats 3" laptop now available, plus 200 others. UPS surface shipping \$4/per normal item. Prices subject to change without notice.

Established 1983. We carry over 1,100 different products. Call today for complete technical information and advice, our free catalog, literature, and solid value.

5-B Pond Park Road
Hingham, MA 02043
Mass: 800-421-8006
or 617-740-2510 4/89
Telex: 671-5348
FAX: 749-2018

800-421-8006

HOURS:
M-F 8:30 - 8:00
Sat. 10:00 - 4:00

Finally . . . a low cost, high speed copier for 5¼ and 3½ inch diskettes!

Attach a Victory V3000 Autoloader to your IBM/PC or Apple/Macintosh, enter one or more copy jobs, and walk away! The system automatically copies 5¼ or 3½ inch diskettes—up to 140 per hour. Switching the copy drive takes less than a minute.

Copy Formats Flawlessly.
Victory's Auto-Dup™ software copies different formats or you can

build your own format. Auto-Dup tests the quality of each copy, sorting diskettes into one of two output bins.

Do-It-Yourself Servicing.
The Autoloader's simple component design and diagnostics for checking drive alignment and speed allow you to maintain the system without outside service.

Call (800) 421-0103.
And ask about Victory's family of affordable Autoloaders that support

Hard Drive Back-Up, Serialization, and Custom Label Printing.

VICTORY ENTERPRISES
Technology, Inc.

Victory Plaza
1011 E. 53½ Street
Austin, TX 78751-1728
(512) 450-0801

Internationally call BFI: Paris (33-1) 45330137, Frankfurt (49-6074) 40980, London (44-622) 882467, Milan (39-2) 33100535, Stockholm (46-8) 6269900, or Madrid (34-1) 2559503, or LOADPLAN: London (44-1) 2007733 or Melbourne (61-3) 5254088.

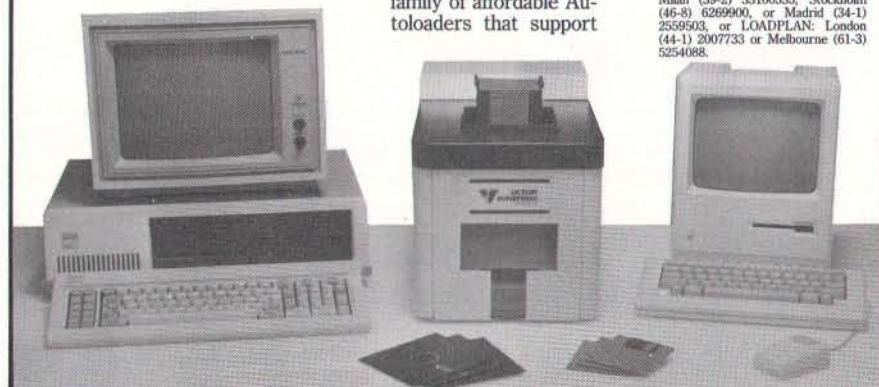

See us at PC EXPO in New York June 20-22, 1989 — Booth 1185

Sir Zed

The battle of the portables continues.

Last month, the Citizen's Advisory Council put on some briefings in the White House. Clearly, I wasn't going to take the big SupersPort 286 into that meeting. For a number of reasons, I wasn't inclined to bring the Toshiba T1100 that Roberta prefers. On the other hand, I did have an incentive to take some notes.

The obvious answer was Sir Zed, the Cambridge Z88. Being no thicker than a slab of wood, Sir Zed fits nicely in the leather shoulder bag I habitually carry. He went through the security x-ray system nicely (of course, they were expecting us and I was in the company of a few generals, so they may have been less inclined to reject large, solid objects than they might otherwise have been).

The Z88 is covered with a thin rubber film, and the keys make no sound at all when you type on it. It is thus eminently suitable for taking notes when you don't want to distract anyone. The LCD is a bit small, but I found that the light spill from the overhead projector being used was sufficient to get the job done. All in all, Sir Zed performed heroically. Meanwhile, I have been learning more about the machine.

First, it is really far more useful than I at first supposed. Most of my problems have been due to not knowing how to operate it. In my defense, there are only two ways to learn how to use this machine. First, you can go over the documents a word at a time, making notes as you go; second, you can ask someone who has used it a lot. The first method doesn't always work, because the documents are awful, the index is worse, and the help files are nearly useless.

Sir Clive Sinclair's little machine will in fact do everything it's advertised to do, which is to say just about everything you expect it to; but you will sweat blood learning how to make it do it.

Item: the primary machine has 32K bytes of memory, the same amount as an NEC PC-8201 or a Tandy Model 100; but whereas those machines save files only once, the Z88 has two ways to save its files. The first is that it just saves them: if you exit the combination word processor/spreadsheet called Pipe-dream, your file is automatically saved whether you want it to be or not. It doesn't have a filename (unless you give it one), but it does have a date and time when last accessed.

You can also explicitly save your file under a filename you provide. When you

continued

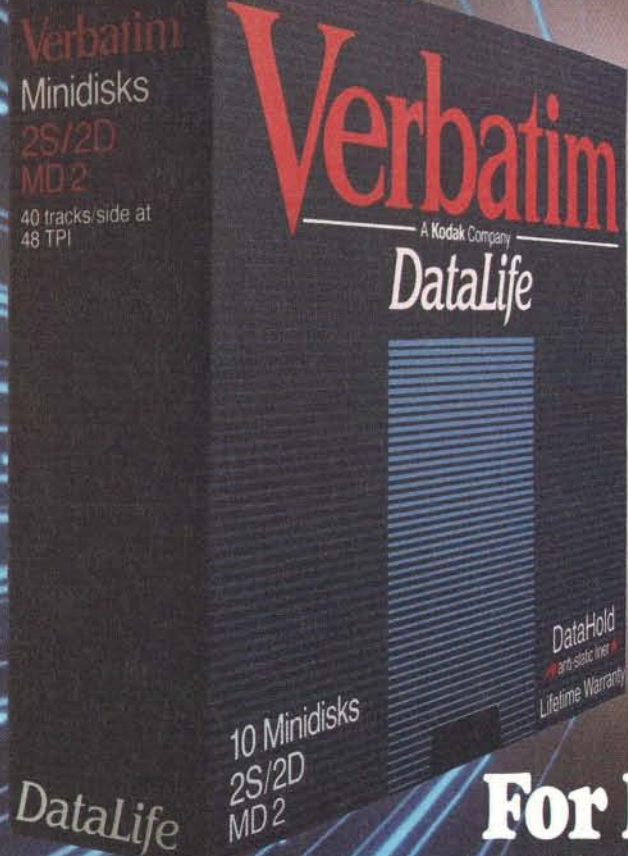

For People Who Put A Premium On Performance. And Protection.

The more invaluable your data is to you, the more you'll value Verbatim.® Because when it comes to high performance and data protection, Verbatim has the winning combination no other floppies can copy.

Consider this: Verbatim DataLife® floppies are engineered to perform an average of 50 million revolutions. That's 15 times the industry standard.

Then consider that Verbatim DataLifePlus™ and DataLife HD 5¼" disks were the first floppies to be factory formatted.

Verbatim also gives you plenty to consider when it comes to data protection. After all, nearly 50% of all computer users have lost time and money due to accidental data loss. That's why Verbatim offers advantages like DataHold™ and DataHold II



anti-static liners. So static charges are dispersed before they ever have a chance to build up.

For the world's ultimate data protection, DataLifePlus floppies have an exclusive DuPont Teflon® coating. So fingerprints and spills can be easily wiped from the recording surface.

And of course, all Verbatim floppy disks are tested to be 100% error free and are backed by a lifetime warranty.

Verbatim data cassettes and cartridges, 8", 5¼" and 3½" diskettes. For people who put a premium on performance and protection.

For more information on the full line of high-quality Verbatim products call 1-800-538-8589.

© Teflon is a DuPont registered trademark.



DOING MORE FOR THE DATA PROCESS™

do, the default is to save it on :RAM.0, which is the 32K-byte main system memory. However, the file that it automatically saves when you exit Pipedream hasn't gone away, so you now have two copies of your file.

It doesn't take long before that 32K-byte memory is filled, after which an attempt to save gets you an error message. This happened to me in Hawaii in the middle of the Grand Challenges to Computational Science conference. I was listening to a speaker and trying to make notes and trying to keep my file, and I certainly didn't have the Z88's documents with me.

I tried the machine's "help" files, but I needn't have bothered. There's very little help there, at least not about the file system. If you want to use your Z88 during important meetings, *learn it first*; you can't learn while things are going on, and worse, if you're not careful, you may discover you can't save your work. That's precisely what happened to me in Hawaii.

Once out of the conference, I had time to think. My Z88 has a 512K-byte RAM cartridge in it. I surely didn't have any 512K bytes of files on it. Clearly, I was not accessing that cartridge. How to do that? It turned out to be easy: I could save files to the RAM cartridge by explicitly saving the file as :RAM.1\filename after pressing Control-F-S. Actually, the Z88 has no Control key, but there is a key marked with a diamond that works about the same. (There's also a key marked with a square, which works about the way the Apple "Command" or Splat key works.)

Anyway, the only problem is that once you save a file as :RAM.1\filename, the filename doesn't default to that; the default remains :RAM.0. There are two ways out of that. One way is, immedi-

ately after you save the file, do Control-F-L and LOAD :RAM.1\filename. Then it will default to that name.

The other way is to do a Control-F-C, which will give you the opportunity to name the file and, as you name it, you can give it the :RAM.1 designation. After that, it will automatically save to that name and "drive" when you do a Control-F-S.

Once you have done that, you need to go to the on-screen Index and enter the Setup Panel. Change the name of the default device to :RAM.1; that done, you aren't finished. Next, go to the Filer (you can press the "Square-F" keys to get there or go through the Index menu). You won't see "Select Device" on the list of options the Filer gives you, but if you go down-arrow, it's there, off the screen. (There are many menu items like that, hidden off-screen, with no indication there's anything more down there. As a general principle, if you use the Z88, try doing a down-arrow off the bottom of every menu screen. The results will surprise you.)

Anyway, enter "Select Device" and set the default to :RAM.1. This works until you turn the machine off, after which the device defaults to :RAM.0 again.

The odd part is that you soon get used to doing things this way.

Losing Files

Interesting: in a previous column, I reported lost files, and I immediately received a great deal of mail saying that wasn't possible. One letter from a Z88 dealer in Ada, Ohio, says, "Do you seriously think that a company would put a computer on the market with disappearing files?" To which I can only reply, alas, after 10 years in this business, I *know* that companies, some of them

major, will put computers on the market with just about every imaginable defect; and that about half of those companies will then hire PR people to try to convince me, "That's not a bug, it's a feature!"

However, Egil Fjeldahl, a reader in Lerum, Sweden, reports, "I got my Z88 in May last year, and immediately I started to lose whatever I had written just like you did." He discovered the problem was printer drivers, and his conclusion is, "The Z88 should not be filled up too much. When there is little [memory] room left, some procedure may zap the machine." It's a conclusion I agree with. Fortunately, it's a condition remedied by adding a RAM cartridge.

Another possible way to lose files is if the little plastic door covering the cartridge slots gets knocked open. Unless you keep the Z88 in some kind of form-fitted case, this isn't as unlikely as I wish it were; I now believe it's what happened to me the first time I lost all my files. Note that the Z88 documents explicitly say never to open that door when the machine is turned off; the way you change cartridges is to turn on the machine, get to the Index menu, and then open the door.

However, now that I know how to save stuff to the :RAM.1 cartridge (which in my case is 512K bytes, but I'll concede that you can do nicely with 128K bytes), I keep the Z88 in my shoulder bag rather than in an old Wingz bag. I haven't lost any more files. Whatever my problem, it was one of a kind.

Moreover, during the Microsoft Software Seminar, the Z88 performed heroically. I was able to make plenty of notes without disturbing the others; while behind me, someone clicking away on a T1100 was getting periodic dirty looks.

continued

MULTI-CHANNEL SERIAL I/O FOR YOUR COMPUTER

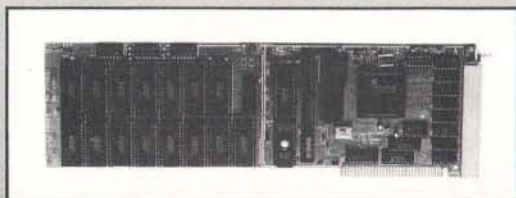

PCSS-8IM

GTEK[®]
INC.

Development Hardware & Software
P. O. Box 2310
Bay St. Louis, MS 39521-2310

Order Toll Free 1-800-255-GTEK (4835)

Fax: 1-601-467-0935 MS & Technical Support 1-601-467-8048

PCSS-8IM

For IBM PC/AT compatible bus

- Serial Communication Co-processor board with 8 channels per card.
- Up to 2 Megabytes of dynamically allocated buffer memory.
- Upward compatible with the PCSS-8I.
- Baud rates up to 57,600 baud.
- 8 RJ-11 modular connectors.

MCSS-9IM

For IBM Micro-Channel compatible bus

- As above except 1 Megabyte of dynamically allocated buffer memory.
- Up to 9 I/O channels, upwardly compatible with PCSS-8I.

MCSS-6T

For IBM Micro-Channel compatible bus

- Serial I/O card adds 6 channels to a Micro-Channel machine.

As with all our serial cards, Bios enhancement software is included. Other cards are available for all your serial I/O needs: PCSS-8X, PCSS-8I, PCSS-4X. All software is upwardly compatible. Upgrade cards without code re-writes!

PC/AT and Micro-Channel are registered trademarks of IBM Corp.

10 YEARS

Microsoft Excel. The power spreadsheet.

If you have the power, we have the spreadsheet: Microsoft Excel. It takes full advantage of the power of 286- and 386-based computers. And that helps you excel in three important ways.

First, Microsoft Excel's analytic tools let you work faster and consolidate data more easily.

Its reporting tools let you create annual-report-quality output and produce presentation graphics.

And its customization tools let you create macros easily and build custom programs.

Microsoft Excel is also compatible with Lotus™ 1-2-3®. So it's easy to integrate into your office.

Come in and see Microsoft Excel today. And find out why we call it the most powerful spreadsheet for powerful personal computers.



\$225

Cutting edge software needs the cutting edge mouse.

If you want to take full advantage of today's cutting edge software and graphics applications, you need the Microsoft® Mouse. It's the fastest way to interact with a wealth of new business and graphics programs such as Microsoft Excel for Windows and DOS 4.0.

As you'd expect from the software industry leader, our Mouse outperforms all others. It points more accurately, takes up less desk space, and doesn't even need a pad. What's more, the Microsoft Mouse comes in three popular software packages - Microsoft Windows/286 and PC Paintbrush® for Windows; Microsoft Paintbrush and Mouse Menus; and EasyCAD™ 2 and Mouse Menus.

Take a look at the Microsoft Mouse. Once you've got the feel of it, you'll never want to let go.

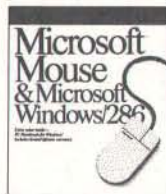

\$135 Microsoft®

WAREHOUSE DATA PRODUCTS

2727 W. Glendale Ave., Phoenix, AZ 85051
Phone Hours: Mon. thru Fri. 6:30 AM-9:00 PM MST
Saturday 9:00 AM-5:00 PM MST
Technical Support: 1-800-421-3135

Division of
AZ Computer Corporation

TO ORDER IN THE U.S.A. & CANADA

1-800-421-3135

We Welcome International Accounts
Call Our Fax Line (602) 246-7805

It really works. For everyone!

Introducing Microsoft® Works, one simple program that combines the four most important business tools. Everything you need to work smarter - without working harder!

New Microsoft Works for IBM® Personal Computers and compatibles and for the IBM Personal System/2™ Series offers easy-to-use word processing, database management, spreadsheets, and communications. And they all work together smoothly to save you time and effort.

Microsoft Works is the one software program that works for everyone. Come in today and discover how it will work for you!



\$89

Brand Name, Wide Carriage, Daisy Wheel Printer

Model 3550

Our Price

\$499

Suggested Retail \$1195

SOFTWARE

ACCOUNTING	INTEGRATED	LANGUAGES	UTILITIES
ACC PAC BPI \$234	Enable OA \$359	Flowchart II Plus \$142	Allways \$40
Dac Easy Acct. 3.0 59	Microsoft Works 89	Microsoft C Compiler	Copy II PC 19
Dac Easy Payroll 59	PFS: 1st Choice 3.0 89	Ver. 5.1 299	Desquivew Ver. 2.2 79
Dollars & Sense 3.1 99	Smart System 469	M5 Fortran Ver. 4.1 295	Fastback Plus 104
Managing Your Money 5.0 125	DESKTOP PUBLISHING	M5 Macro Assembler	Fastrax 30
Peachtree Complete 149	Pagemaker Ver. 3.0 \$479	Ver. 5.1 99	Formworks w/Fill & File 85
Quicken 2.0 30	PFS: First Publisher 2.0 73	MS/Quick Basic 4.5 65	Graph in the Box 2 73
JATA BASE MANAGERS	Ventura Publisher 2.0 509	MS/Quick C 65	Mace Gold 81
Clipper \$429	SPREADSHEET	Turbo Basic 1.1 65	Microsoft Windows 286
Data Perfect 283	Lotus 1-2-3 w/Allways \$305	Turbo C Ver. 2.0 95	Ver. 2.1 63
DBase IV 463	Lucid 3D 78	Turbo Pascal 5.0 99	Norton Advanced 4.5 79
DBase IV Developers Ed. 799	MS/PC Excel 2.1 225	COMMUNICATIONS	PC Tools Deluxe 39
DB-XL Diamond 119	Quattro 162	Carbon Copy Plus \$115	Sidekick Plus 125
Fox Base Plus 2.1 199	Plan Perfect 189	PC Anywhere III 69	Timeslips III 113
Paradox 3.0 469	PROJECT MANAGER	Procomm Plus 44	CAD/GRAPHICS
PFS: Profile 165	Timeline Ver. 3.0 \$364	WORD PROCESSING	Design Cad Ver. 2.1 \$219
Q&A 3.0 215	Harvard Total Proj. Mgr. 369	Grammatik III \$49	Generic Cad Level 3 133
Quicksilver Diamond 329	MULTI-USER SOFTWARE	SPF/PC 169	Grasp 269
Revelation Advanced 469	Fox Base Plus \$299	Word Perfect Ver. 5.0 225	Harvard Graphics Ver. 2.1 76
RBase for DOS 473	Microsoft Word 205	Word Perfect Library Ver. 2.0 65	PFS: First Pub. Ver. 2.0 73
	Word Perfect 339	Wordstar Pro 5.0 199	Printshop 36
			Showpartner F.X. 199

HARDWARE

COMPUTERS	HARD CARDS	LOGITECH	BOARDS
ARC	Plus 20 MB \$529	HiRes Bus \$79	AST
386 Skyscraper \$2729	Plus 40 MB 669	New Bus/Serial 81	Rampage 286 Plus
Pro Turbo 88 739	HARD DRIVES	PS/2 59	w/512K \$529
Pro Turbo 286 1209	SEAGATE	Scanman Hi-Res 189	EVEREX
ACER	ST-225 20 MB w/cont. \$279	PRINTERS	2MB Above PC/XT 61
710 w/o Monitor 785	ST-238 30 MB w/cont. 299	CITIZEN	3MB Above AT w/o Mem 89
900 w/o Monitor 1199	40 MB AT 251 369	180D \$165	Multifunction EMS 95
AT&T	MONITORS	MSP45 419	INTEL
6286 WGS 1395	Amdek 41D \$145	Tribute 224 610	2MB 286 Plus w/512K 419
6300 WGS 899	Mitsubishi Diamond w/tilt 509	OKIDATA	Above 286 I/O 469
6386 WGS, 80MG, 20 Hz 3795	NEC Multisync 32A 529	OKI 320 355	Connection Co-Processor 739
TOSHIBA LAPTOPS	NEC Multisync 3D 679	OKI 390 499	ORCHID
T 1200 FB \$1579	Princeton Max 15 249	PANASONIC	Ram Quest Extra PS/2 339
T 1200 HB 2419	Princeton Ultra 16 849	1124 339	Tiny Turbo 289
T 1600 3359	Samsung Amber Flat 89	1191 (240 CPS) 254	MODEMS
T 3100 E 2839	Samsung RGB 235	STAR MICRONICS	300/1200 w/Soft \$69
TS200 140 6389	Samsung EGA 369	NX1000 179	2400 EXT. Error Cor. 189
VGA/EGA BOARDS	Samsung Multisync 449	NX1000 Color 238	EVEREX
ATI EGA Wonder 800 \$239	Seiko 1430 599	ACCESSORIES	2400 EXT. Error Cor. 189
ATI VGA Wonder 285	Zenith 1490 629	Copy II PC Deluxe Bd \$109	HAYES
Orchid Pro Designer 299	MICE/SCANNERS	Curtis Ruby + 69	1200B INT w/Soft 289
Paradise 480 169	Complete	Logical Connection 512K 509	US ROBOTICS
Paradise VGA Plus 259	Handscanner 400 \$143	Masterpiece 85	1200 Internal w/Software 130
Paradise VGA Pro 449	Answering Machine 220	150 Watt Power Supply 69	2400 w/o Soft 335
Vega V-RAM 509			

USER FRIENDLY TERMS & CONDITIONS:

We welcome international accounts, please call for special pricing. Volume discounts for corporate and institutional orders. We do not charge your credit card until your order is shipped. Shipping minimum is \$5.00. Arizona orders + 6.7% sales tax. Personal/company checks allow fourteen (14) days to clear.

All shipments insured at no extra cost.
All prices are subject to change without notice.
We do not guarantee compatibility.
All trademarks are registered.

BY06



CALL FOR ITEMS NOT SHOWN
1-800-421-3135

MasterCard

VISA

Circle 289 on Reader Service Card



MP386



MP286

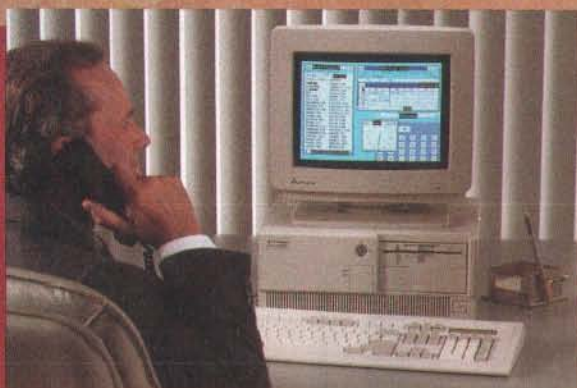

MP386s

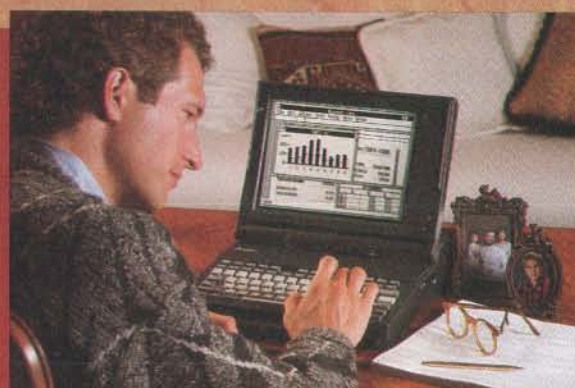

mp286L

CHAOS MANOR

I'm also impressed with battery life. The Z88 uses four alkaline AA batteries, and it seems to get about 20 hours of continuous use from them. I did have one incident. Microsoft gives seminar attendees several huge notebooks and piles of other stuff, as well as a bag to put it all in. I stuffed all that together and put the Z88 between two big notebooks, where it would be safe.

If you leave the Z88 on, it will presently turn itself off to save batteries. You turn on the machine by pressing both Shift keys at once. Next morning in the seminar I did that, and nothing happened. "Aha," I thought, "I have left it where those keys were pressed all night long, and it has used up the batteries. Hardly its fault."

I asked one of the Microsoft PR people if a messenger could go out and get me some batteries and a copy of the *Wall Street Journal*, and then I went back to listening to the presentations, which were interesting but not absorbing. I got to playing around with the Z88 and dumped the batteries out in anticipation of putting in the new ones. But, there being no wastebaskets around, there was no

place to put the old batteries, so I stuffed them back into the machine. Then idly I turned it on.

Worked fine. Hadn't lost a file. I don't to this moment know why it didn't work before I removed and reinserted those batteries, but I'm still running on them.

File Transfer

I have both Z88-to-IBM PC and Z88-to-Macintosh file transfer kits. The Z88-to-Mac kit has this problem: the cable Cambridge supplies is a real beast. It works, but only just; you have to struggle to get it connected to your Mac, and often you'll think it's connected when it isn't. The Z88 end of that cable is just as bad: the Z88 output port is a female 9-pin jack (unlike the IBM PC AT, which has a male 9-pin plug on its serial port). The Cambridge cable thus terminates in a 9-pin male plug, which has two fastening screws on it. However, the Z88 case has no holes for those screws, and in fact the plastic shroud around the output port prevents you from plugging in the cable—a cable supplied by Cambridge—until you remove those screws.

Once you get the cables connected, the

software works splendidly. I never did have to refer to the manual. Of course, Pipedream can accidentally put stuff into a text file that will drive MacWrite slightly nuts, but you can edit that out.

You can also transfer files from the Mac to the Z88. Since there is no such thing as a portable Mac (at least not just yet), the Z88 may be the very thing for Mac users who must have a laptop. Alas, although there is a program to convert Pipedream spreadsheet data to PC Lotus 1-2-3, there does not seem to be a conversion for Z88 spreadsheet data to Macintosh Excel format. Text and BASIC files transfer nicely.

The Z88-to-PC link is also straightforward, provided you're talking about connecting to a vanilla PC. If you have an AT, it's a bit more complicated.

The cable Cambridge supplies with their PC link cartridge terminates in a standard 25-pin female RS-232C connector suitable for connecting to the serial port on a PC. The AT, however, has a 9-pin male connector. Recall that the Z88 terminates in a 9-pin female connector, and you'll see the problem. The four-headed LapLink cables, for exam-

If Everyone Worked Alike, We Would Only Have To Make One Computer.

Mitsubishi Electronics America, Inc.
Information Systems Division
991 Knox Street, Torrance, CA 90502.
Mitsubishi Electric Sales Canada, Inc.
8885 Woodbine Avenue
Markham, Ontario L3R 5G1.

© 1989 Mitsubishi Electronics America, Inc.
Mitsubishi is a registered trademark of Mitsubishi Electric Corp., Tokyo.

But they don't. So we created a broad line of PC compatible computers to meet your individual computing needs while working within your budget.

Whether you are with a Fortune 1000 corporation, manage a small business or work at home, there's a Mitsubishi® computer to fit your requirements in size, speed and power.

The sleek mp286L portable is easy to use at home or carry from home to the office. The MP286 is a small footprint desktop PC. For expandability, it's the 32-bit MP386 or the new 16 MHz MP386s — the perfect balance of size and power.

For greater convenience and performance flexibility, you can integrate your PC with a wide choice of Mitsubishi peripherals including color monitors, disk drives, scanners and color thermal transfer printers.

See our full line at your authorized Mitsubishi dealer who is ready to listen and recommend just the right Mitsubishi system and peripherals. Or contact the Mitsubishi Information Center by calling in the U.S. and Canada 1-800-556-1234, ext. 25 (in California, 1-800-441-2345, ext. 25).

With over a decade of experience, Mitsubishi has delivered over a half million personal computers earning a reputation for unparalleled quality and dependability.

Mitsubishi Electronics. Personal computers and personal service.



Circle 184 on Reader Service Card (DEALERS: 185)

CHAOS MANOR

ple, won't work since they're female-to-female. For some reason, a standard 9-pin-male-to-9-pin-female mouse extension cable won't work either.

In fact, almost nothing will work. Before it was over, I had the most incredible lash-up of cables and gender changers you've ever seen, and I still couldn't get the Z-386 and Z88 talking to each other. Eventually, I found an adapter made by MicroSpeed to adapt their FastTrap trackball to a standard mouse cable; attaching that to the cable Cambridge supplied worked fine, once I'd removed the silly screws from Cambridge's plug so that I could get it inserted into the Z88.

That done, the software works fine. No manual needed. You can transfer files back and forth, and indeed, if you have built a spreadsheet in the Z88, you can convert it to a Lotus 1-2-3 file as you transfer. The software is all menu-driven and quite elegant.

Bottom Line

All in all, the Z88 is expensive, sometimes infuriating, hard to learn, at times difficult to operate, and often plagued with silly glitches like the cable screws.

The command structure is goofy, and you keep wishing they had given you ways to change many of the defaults. The help files are useless, and the documents are wretchedly indexed and not well organized.

Concede all that, and it's still interesting. If you have a requirement for a small and handy computer, mostly for word processing but with a general-purpose capability, you may find there's no substitute for the Z88. Once you've learned to use it, the little machine looks nearly indispensable.

It's light in weight, small in bulk, and surprisingly powerful. The BASIC in the machine is quite elegant. I have a lot of quarrels with the Pipedream combination spreadsheet and word processor, but in fact it does both jobs well enough to get by. Once you solve the cable problem, it's easy to squirt your stuff into a full-featured machine, PC or Macintosh, for editing. The screen is fairly small, but it's about as readable as a paperback book, meaning that if there's light enough to read by, there's light enough to work by; and the Z88 is handy enough that you can pull it out and work almost

anywhere. Moreover, you're more likely to have it when you need it.

I wouldn't recommend the Z88 as your only machine, but I'm sure getting attached to mine. I'll never write novels with it, and I doubt it will ever be the only machine I carry on long trips; but I don't know any other computer I could have used in a White House briefing.

Wizard

It may not come as a great surprise to learn that I am a gadget addict, and I particularly like small electronic whizbangs. From the days of the first overpriced Hewlett-Packard scientific calculators to the present, I have been hooked on these things.

Indeed, I regret that my Casio FX-7100 combination scientific calculator and alarm clock is a basket case. Is there anyone out there who either has one in working condition and is willing to sell or can fix mine, starting with a plastic bag of parts? I really miss that little gadget.

Anyway, the Sharp OZ-7000 Wizard Electronic Organiser wouldn't do to

continued

PS/2® MEMORY

Introducing **OS/RAM4™**.

- ✓ 4 megabytes of memory.
- ✓ Extended and expanded memory. LIM 4.0.
- ✓ Works with all of your programs.
- ✓ Run DOS or OS/2 effortlessly.
- ✓ Fast and simple switchless installation.
- ✓ Auto-configuration for all operating systems.
- ✓ Works in all Micro Channel™ computers.
- ✓ Expanded memory 10 times faster than Intel.
- ✓ Risk free guarantee. Two year warranty.
- ✓ IBM approved ID. \$349 0K.

Call today 1-800-234-4232 or 617-273-1818

cec Capital Equipment Corp.
Burlington, MA. 01803

PS/2 and Micro Channel are trademarks of IBM

ther analysis and report generation.

You can also generate a lot of notes, phone lists, schedule stuff, and suchlike on your PC, then ship it over to the Wizard, thus saving no end of hunt-and-peck entry on the Wizard's silly little ABC keyboard.

Like all Traveling Software's products, Wizard PC-Link works without surprises. You'll spend a lot more time in the Wizard manual than you will in Traveling Software's. Still, it is worth reading, since it will suggest things you haven't thought of, like sharing Wizard and SideKick files. If you're reading this and you have or are getting a Wizard, you will need Wizard PC-Link.

GoScript

Macintosh users with LaserWriters can skip this section. If you're using a PC and have a Hewlett-Packard LaserJet, ThinkJet, or DeskJet (or a 24-pin dot-matrix printer), you know you can't do fancy PostScript printing the way your Apple colleagues can; or at least you couldn't until now.

Comes now GoScript, from LaserGo, a program that understands PostScript output from, say, Xerox Ventura Publisher, Aldus PageMaker, or, for that matter, just Microsoft Word or Borland Quattro; and it can take that PostScript output and translate it into something to drive your printer. Rotation, multiple fonts, and font scaling; it's all there.

That's the good news.

The bad news is that GoScript is glacially slow. First, it has to do the calculations (it helps if you have a math coprocessor, but it isn't required). Then it has to send those instructions, dot by dot (300 dots per inch), out to your printer. This can take long enough for you to have lunch. You may want to start growing a beard.

On the other hand, it works. I don't know of any other way to get that kind of performance out of an ordinary laser printer, much less ink-jet and dot-matrix printers. If you need PostScript output and you're willing to wait while it does the job, get LaserGo's GoScript.

Northgate Omni Key/102

Regular readers of this column know I worry a lot about keyboards. Given the number of words I turn out a month, it's hardly surprising. I pay attention to feel, key layout, sturdiness, and just about everything else.

After several months of testing, we've adopted a new standard keyboard here at Chaos Manor. What we've settled on is the Northgate Omni Key/102.

make notes with in a White House briefing or anywhere else, but it is way up near the top on my list of neat gadgets. It's also likely to generate some strong opinions, because if you're not a confirmed gadget lover, you may not care for the Wizard at all.

The Wizard is about the size of an old-fashioned cigar case, small enough to be carried in an inside coat pocket but bulky—and heavy—enough to be noticed if it's there. It has a whole bunch of features: calendar, schedule book, alarm, memo, fairly simple (not scientific) calculator, and home and world clock; and if those aren't enough, you can buy small IC cards that let it do other things (e.g., keep a "Do List" and, more important, record trip expenses).

Alas, while it does all those things, it doesn't do any of them particularly well, nor is it all that easy to remember how to use it. I have just noticed, for instance, that the clock is about 4 minutes slow; but for the life of me, I can't figure out how to set it. I know it's simple, and I did manage it on my last trip; but it's not obvious, and short of going to the documents, I'll never figure it out.

Entering notes in the Wizard is a pain. There's a full alphabetic keyboard, but it's ABC, not QWERTY. The keys are rather awkwardly placed on the right side with the screen on the left, so that

you can look at either the screen or the keyboard but not both; and I for one am never going to be a touch-typist on this machine.

It's fairly simple to enter numbers and times and such, but once again, using the scheduler gets awkward as soon as you want to spell out in any detail just what it is you are scheduling. Ditto for entering telephone numbers and addresses: entering those is *work*. The optional expense report manager is easier to use, but so is a notebook.

All in all, the Wizard is more notable for what *can* be done in a small package like this than for what *has been* done. I carry it around to show people, and I like the way it impresses them; but I really have to confess I don't *use* it all that much. If you love gadgets, you'll love this for its own sake. If you're just trying to keep notes and file your trip expense reports, don't throw away your Day-Timer just yet.

Wizard PC-Link

One thing that makes the Wizard a bit more useful is Traveling Software's Wizard PC-Link, which is software and a cable that lets you connect your Wizard to a PC-compatible. There's even a Lotus 1-2-3 Expense Manager template: squirt over your Wizard expense files, and you can read them into this template for fur-

CHAOS MANOR

Understand, there's nothing wrong with our previous DataDesk keyboards. They continue to work just fine, and we like them a lot more than the keyboards that come as standard equipment with most machines.

Northgate keyboards have two superior features. First, there's a definite mechanical click that you can feel as well as hear associated with each key press. I like that. Let me hasten to add that I know some people do *not* like the tactile key-click feature; in which case, I recommend they use a DataDesk keyboard, which has a good feel, but different from the Northgate keyboards.

The second reason I like Northgate keyboards is the key layout. The Escape key is in the upper left, and I especially like the function keys: on the Omni Key/102, all 12 function keys are on the left side of the keyboard, 10 of them in the same place they were on the original IBM PC keyboard, with F11 and F12 above them.

In theory, it ought to be a good idea to put the function keys in a row across the top. That way, the program can do you a little diagram with the explanations of the function keys laid out exactly as are the keys themselves. In practice, I find that it's just plain easier to find and use the function keys when they are bunched over to the left. It's certainly easier to get at them with the left little finger.

There's one more neat thing about the Northgate keyboards. They come with a tiny (about 50 bytes) TSR program called POURVOUS.COM (which was written to suit my prejudices). This program re-maps your keyboard so that Shift-comma is a comma, and ditto with periods. If you want the right- and left-arrow symbols, you do Left Shift-Alt-comma or period to get them. POURVOUS.COM works invisibly with all the software I know, including DESQview. I've installed it in all my machines, including portables.

The Northgate Omni Key/102 has become the standard keyboard at Chaos Manor. Recommended.

Models of Doom

Back in March 1972, Dennis and Donella Meadows published *The Limits to Growth*, a highly influential book that grew out of research sponsored by a group of wealthy industrialists calling themselves "The Club of Rome." The book presented a pessimistic view of the future; in contrast to the idea of progress, which had dominated Western intellectual thought through the previous 150 years, it predicted an unending

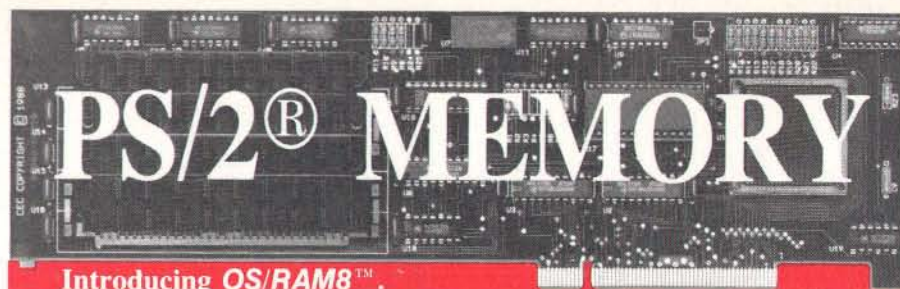

Introducing OS/RAM8™

- ✓ 8 Mbytes of memory + 2 serial ports.
- ✓ Extended and expanded memory. LIM 4.0.
- ✓ Works with all of your programs.
- ✓ Run DOS or OS/2 effortlessly.
- ✓ Fast and simple switchless installation.
- ✓ Auto-configuration for all operating systems.
- ✓ Works in all Micro Channel™ computers.
- ✓ Expanded memory 10 times faster than Intel.
- ✓ Risk free guarantee. Two year warranty.
- ✓ IBM approved ID. \$449 0K.

Call today 1-800-234-4232 or 617-273-1818



Capital Equipment Corp.
Burlington, MA. 01803

PS/2 and Micro Channel are trademarks of IBM

series of disasters: vast upswings in population punctuated with massive die-offs and an unwaveringly steady fall in the "quality of life."

Moreover, there wasn't much we could do. Efforts to stave off one crisis would create an even worse—and totally unavoidable—crisis of another kind.

The Limits to Growth inspired political movements based on the philosophy of "an era of limits." Phrases like "appropriate technology," "limits," "soft paths," and "ecology" became symbols of power. The book was influential in the election of Jimmy Carter as president.

This book was based mostly on a single "systems dynamics world model": a computer simulation developed at MIT by Professor Jay Forrester and presented in considerable detail in his book *World Dynamics* (Wright-Allen Press, 2d ed., 1973). The model consists of some 45 interconnected subsystems: typical subsystems or blocks are NRUR (natural-resource-usage rate), DR (death rate), POL (pollution), CID (capital investment discard), BR (birthrate), and so forth, all of which are interactively connected. That is, agricultural investment increases agricultural output, which increases birthrate but also pollution; pollution decreases agricultural output; and so on. The simulation output includes things like total world population, total pollu-

tion, and quality of life (which, incidentally, peaked in 1940 according to the "standard" model).

By today's standards, the systems dynamics world model is not so impressive, but in 1970 it certainly was. In those days, there was a natural awe and respect for computers—and perhaps even more for those who could persuade computers to do something useful. *World Dynamics* and, even more so, *The Limits to Growth* captured the imaginations of many respected social thinkers. Isaac Asimov popularized many of the conclusions in a *Penthouse* magazine essay concluding not only that humanity was doomed, but that the doom would happen rapidly, probably before the end of the century.

There were counterarguments. I made some of them in a book called *A Step Farther Out*. Members of the faculty of the University of Sussex analyzed *The Limits to Growth* in a scholarly counterblast called *Models of Doom*. Herman Kahn's Hudson Institute published *The Next Two Hundred Years*, with a picture of the future nothing like what you found in *The Limits to Growth*. However, in most academic institutions, there was strong support for the conclusions and recommendations in *The Limits to Growth*.

One thing was lacking in this debate: most of those who were doing the dis-

continued

cussing, whether for or against *The Limits to Growth*, had no means of doing simulations of their own. Computers large enough to handle models of this complexity weren't all that widespread, and time on computers of any size wasn't easy to get. While (to Forrester's great credit) *World Dynamics* presents a thorough mathematical description of the world model, it doesn't give source code except in the language DYNAMO. In those days, few social scientists had

means for producing computer programs in DYNAMO or any other language, even if they had access to suitable machines and compilers. Most of the analyses of *The Limits to Growth* and the *World Dynamics* model on which the book was based had to be done in words and on paper.

By 1978, that wasn't so true. It was then possible to get source code in BASIC for the *World Dynamics* model. I wrote one program myself. Running that pro-

gram demonstrated quite dramatically just how sensitive the *World Dynamics* model was to a key pair of assumptions: that NR (natural resources) was monotonically dwindling and did so at a rate proportional to CI (capital investment), and that birthrate does not fall with increasing wealth.

Moreover, the model had no provision whatever for "resource substitution," although history shows that when a resource becomes scarce, the price rises, and another resource—often one not previously thought useful—is substituted. (The classic example is the use of coal after Britain's timber resources had been exhausted.) I attempted to add such features to the model, but doing that work in BASIC on Old Zeke (my 64K-byte CP/M Z80) and plotting the output on a Diablo daisy-wheel printer was clumsy and time-consuming. Before I finished that work, the intellectual community had found a new fad to scare themselves with.

Extend

The Limits to Growth phenomenon—the extraordinary popularity and influence of a single computer simulation—could happen again, but it seems less likely now that nearly everyone has a desktop computer far more powerful than the one Forrester used. Building up dynamic simulation models—whether of the world or of far simpler systems—is much easier now.

If you're using Extend on your Macintosh, simulation can even be a lot of fun.

Extend is a simulation program that makes use of the Mac's best features. Like the Mac, you can learn to use Extend in a couple of hours. All you need to do is take a bunch of predefined subsystems; connect their inputs and outputs in interesting ways; set the initial conditions; and launch the simulation. Extend will plot the results for you. You can then go back and change anything you like to see what effect, if any, that has on the outcome of whatever you simulated. Extend comes with libraries of subsystems relevant to simple models of electronics, earthquakes, ecology, manufacturing, and other such stuff. There's also a neat tutorial that shows you how to get started.

Once you've learned the basics of Extend, you can do almost anything you like. You can draw new boxes in any shape you like (e.g., one of the tutorials is a model of heating your house; naturally, there's a house, while the roof insulation "box" looks like a roof, and so

continued

ARE YOU STILL DRAWING FLOWCHARTS BY HAND?

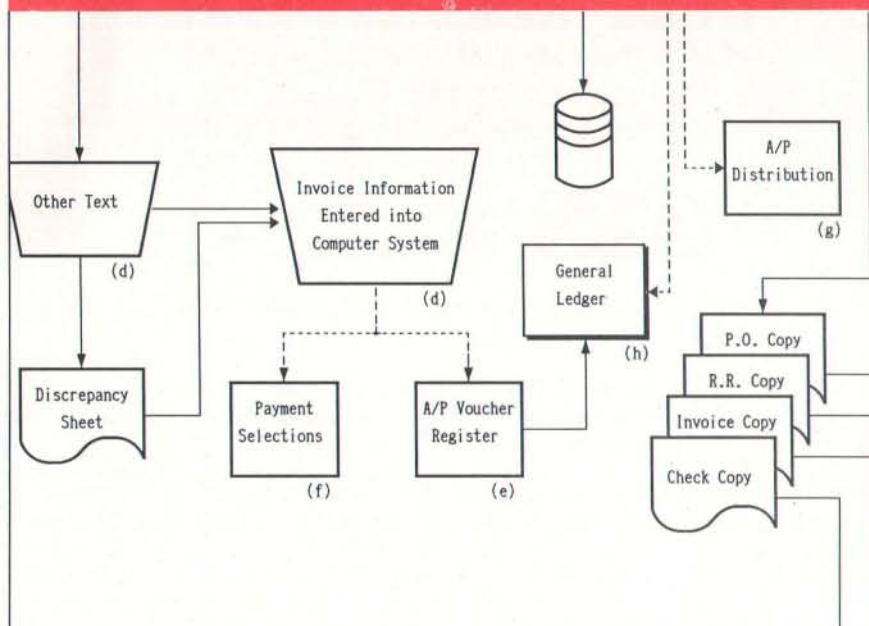

FLOW CHARTING II+

Flow Charting II+ will *amaze* you with its speed, power and simplicity.

- Update and print charts as fast as the situation changes
- See your revisions right away—no long wait for charts to be hand drawn
- Select 26 standard shapes; 10 text fonts
- Tutorial manual makes learning easy
- Runs on IBM or compatibles
- Produces excellent organizational charts!
- Only \$229!

PATTON & PATTON

Software Corporation

Excellence in charting the flow of ideas

For more information, see your local retailer or call
 1-800-525-0082, ext. 47 (outside Calif.) 408-629-5376 (Calif./Int'l.)
 81 Great Oaks Blvd., San Jose, CA 95119

“...I don't know any other computer I could have used in a White House briefing.”

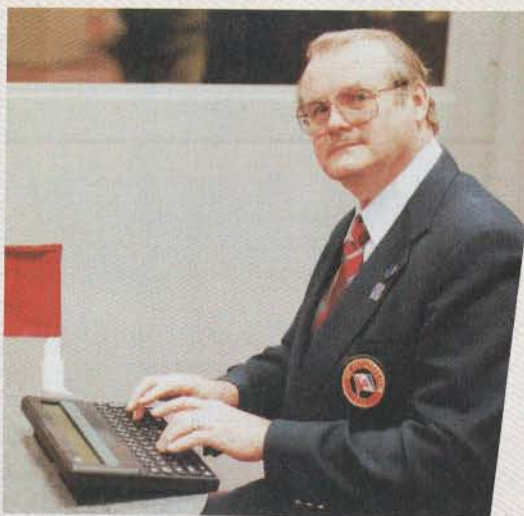

In his *Computing at Chaos Manor* column this month, Jerry Pournelle describes his experiences using the Cambridge Z88. Before you go to another important meeting, give us a call.

800-888-3723

Dealer inquiries call 207-761-3700

Cambridge North America, 424 Cumberland Avenue, Portland, ME 04101

JUNE 1989 • BYTE 131

ITEMS DISCUSSED

Coretest \$20 CORE International 7171 North Federal Hwy. Boca Raton, FL 33487 (407) 997-6055 Inquiry 1031.	Norton Utilities 4.5 Advanced ...\$150 Peter Norton Computing 2210 Wilshire Blvd., Suite 186 Santa Monica, CA 90403 (213) 319-2000 Inquiry 1036.	Vopt \$59.95 Golden Bow Systems 2870 Fifth Ave., Suite 201 San Diego, CA 92103 (619) 298-9349 Inquiry 1041.
Extend\$495 Imagine That, Inc. 7109 Via Carmela San Jose, CA 95139 (408) 365-0305 Inquiry 1032.	Omni Key/102 \$99 Northgate Computer Systems, Inc. 13895 Industrial Park Blvd., Suite 110 Plymouth, MN 55441 (800) 526-2446 Inquiry 1037.	Wizard\$299.99 Sharp Electronics Corp. Sharp Plaza Mahwah, NJ 07430 (201) 529-8200 Inquiry 1042.
GoScript 13 fonts\$195 35 fonts\$395 LaserGo, Inc. 9235 Trade Place, Suite A San Diego, CA 92126 (619) 530-2400 Inquiry 1033.	PM3011/70 \$1150 Distributed Processing Technology 132 Candace Dr. Maitland, FL 32751 (407) 830-5522 Inquiry 1038.	Wizard PC-Link\$149.95 Traveling Software, Inc. 18702 North Creek Pkwy. Bothell, WA 98011 (800) 343-8080 In Washington, (206) 483-8088 Inquiry 1043.
HTest/HFormat \$89.95 Kolod Research, Inc. P.O. Box 68 Glenview, IL 60025 (312) 291-1586 Inquiry 1034.	SpeedStor \$99 Storage Dimensions, Inc. 2145 Hamilton Ave. San Jose, CA 95125 (408) 879-0300 Inquiry 1039.	Z88\$599 Cambridge North America 424 Cumberland Ave. Portland, ME 04101 (207) 761-3700 Inquiry 1044.
Mace Utilities Gold\$149 Paul Mace Software, Inc. 400 Williamson Way Ashland, OR 97520 (503) 488-2322 Inquiry 1035.	SpinRite \$59 Gibson Research Corp. 22991 La Cadena Laguna Hills, CA 92653 (714) 830-2200 Inquiry 1040.	

forth). You can define the boxes in any detail you want: number of inputs, number of outputs, relation of input to output, and so on. You can make things as simple as adding two integers, or as complex as multiplying two complex matrices and getting their eigenvalues.

I've been using the program for only a few weeks, and I estimate that if I really wanted to put up the *World Dynamics* model in Extend, I could probably get it done in two weeks of part-time work; after which, I could test that model for sensitivity to its assumptions in an hour and add new features almost without limit. I'm not likely to do that, but I'm pretty sure I could.

Last night, Jim Ransom, Mike Hyson, and I worked on refining the SSX (Space Ship Experimental) documents so that we could get a new briefing off to Washington. After we got that done, we started playing with Extend and managed to chew up a few more hours just having fun: we were modeling a pond in

which piranha eat goldfish, and goldfish eat dead piranha; we wanted to add a third critter and get stable populations. That turns out to be hard to do: we got to see just what a tough job God has.

I sure wish I'd had Extend back in the days when a few of us space enthusiasts tried to insist that Forrester modeled the wrong system: the resource base for the human race consists not merely of this finite earth, but a full system of nine planets, 35 moons, a million asteroids, and a billion comets, all orbiting a very large and benign thermonuclear power plant that needs no maintenance.

Next time someone shouts "Doom!" and points to a computer model, I'll haul out Extend.

Highly recommended.

Winding Down

There's still an enormous stack of stuff on the ready line. The flood of good hardware and software for both PCompatibles and the Mac amazes me.

The book of the month is by Nathan Glazer, *The Limits of Social Policy* (Harvard University Press, 1988). The game of the month is *The Halls of Montezuma* (Strategic Studies Group, 1747 Orleans Ct., Walnut Creek, CA 94598, (415) 932-3019). I had a lot of fun playing the *Battle of Inchon*.

Next month, OS/2 versus Unix, unless someone else has said it all better than I can. ■

Jerry Pournelle holds a doctorate in psychology and is a science fiction writer who also earns a comfortable living writing about computers present and future. Jerry welcomes readers' comments and opinions. Send a self-addressed, stamped envelope to Jerry Pournelle, c/o BYTE, One Phoenix Mill Lane, Peterborough, NH 03458. Please put your address on the letter as well as on the envelope. Due to the high volume of letters, Jerry cannot guarantee a personal reply. You can also contact him on BIX as "jerry."

"TOPSPEED IS ONE GREAT COMPILER!"

— Jerry Pournelle
 BYTE Information Exchange

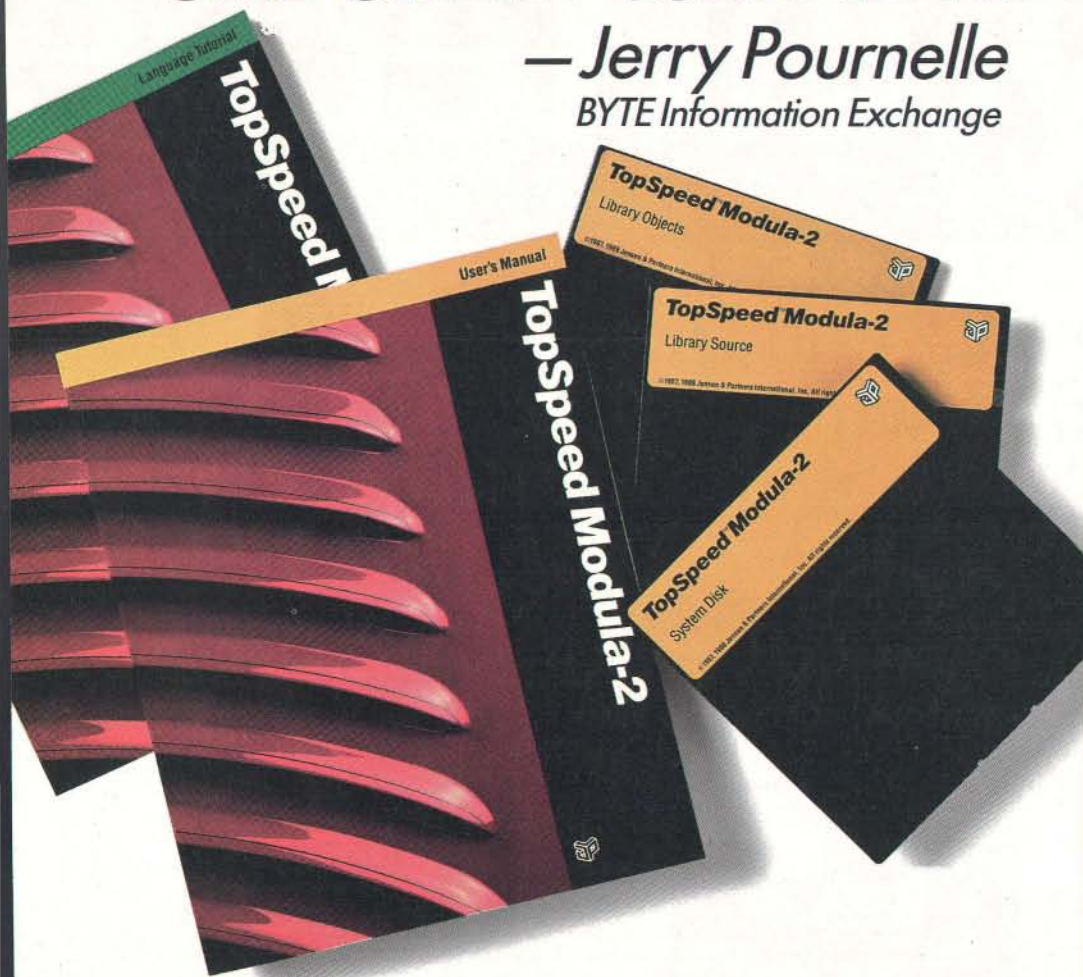

"Everything about this product exudes quality...it is one of the most complete and powerful development systems available today."

Scott Robert Ladd
 Computer Language

"...TopSpeed™ is surely one of the finest new products introduced to date in the PC arena...DDJ doesn't give unqualified raves very often, but there's no question about it in this case; JPI's TopSpeed Modula-2 is first-rate."

Kent Porter
 Dr. Dobbs Journal

"JPI Modula-2 looks like another classic in the making. It generates code as good as or better than leading C compilers and the programming environment is a genuine pleasure to use."

Dick Pountain
 BYTE Magazine

In England and Europe contact:

Jensen & Partners UK Ltd., 63 Clerkenwell Road, London EC1M 5NP. Phone: (01)253-4333. DOS Compiler: £59.95, TechKit £34.95, VID £34.95, DOS 3-Pack £119.95, OS/2 Compiler £124.95.

Handling charges: In UK please phone for VAT & P&P. In Europe, add £6 for up to 3 products, £2 for each add'l product.

TopSpeed Modula-2 is a high-speed optimizing compiler (3,000-5,000 lines/min. on a PC AT 8MHz), integrated menu-driven environment with multi-window/multi-file editor, automatic *make*, fast smart linker. All Modula-2 sources to libraries included. BONUS: Complete high-speed window management module included with source. 258-page User's Manual and 190-page Language Tutorial.

OS/2 version now available: Runs in protected mode under OS/2 Standard or Extended Edition 1.0 or 1.1. Generates standard .OBJ files and .DLLs. Comes with fast, smart linker, built-in assembler. Modula-2 and assembly source code for libraries included (and fully compatible with DOS version). Full support of all OS/2 calls. Same integrated configurable environment as the DOS version.

VID (Visual Interactive Debugger): An integrated multi-window symbolic debugger for DOS. View source code as it executes. Single-step and trace through multiple modules. Qualify breakpoints with expressions. Examine & modify variables in symbolic form, including arrays, records & pointers. Automatic trace of variables accessed. Includes symbolic disassembler, execution profiler. 78-page manual. (DOS only)

The TechKit™ includes: Assembler source for start-up code and run-time library, JPI TopSpeed Assembler (30,000 lines/min.), TSR module, communications driver, PROM locator, dynamic overlays, and technical information. 72-page manual. (DOS only)

System Requirements: IBM PC or compatible, 384K available RAM, two floppy drives (hard disk recommended).



TopSpeed's seamlessly integrated environment.



VID (Visual Interactive Debugger): power without complexity.

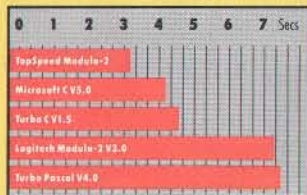

Sieve benchmark measured by the British Standards Institution (BSI)—25 iterations on an 8MHz AT.

DOS Compiler \$99.95

TechKit \$59.95

VID \$59.95

DOS 3-Pack \$199.95

(Compiler, TechKit & VID)

OS/2 Compiler \$195.00

To Order:

In the US, call:
1-800-543-5202

In Canada, call:
1-800-543-8452

Or mail us your order with a check, money order, or VISA/MC information. 30-day unconditional money-back guarantee.

Shipping & handling charges:

In North America: add \$5 for each product ordered. CA residents please add applicable sales tax. Overseas: Add \$20 for EACH compiler and \$8 for each other product. 3-pack s & h is \$36.00.



Jensen & Partners International

1101 San Antonio Rd.
 Suite 301
 Mountain View, CA 94043
 Phone: (415)967-3200

TopSpeed and TechKit are trademarks of Jensen & Partners International. Other brand and product names are trademarks or registered trademarks of their respective holders.

Quarterdeck

DESQview 2.2 and DESQview 386. The multitasking, windowing environments that work with your favorite software.

DESQview™ is the operating environment that brings OS/2™ power to DOS. And it lets you, with your trusty 8088, 8086, 80286, or 80386 PC, leap into the next generation in PC productivity. For not much money. And without throwing away your favorite software.

Introducing DESQview 2.2

And now, DESQview 2.2 adds capabilities, performance, and compatibility enhancements you've been asking for:

Like being able to fine tune DESQview performance "on the fly." Run Lotus Express and Metro. And the Intel Connection Co Processor. Even use the DOS 4.0 shell with DESQview. Have DESQview automatically install Quattro, Sprint, Aldus PageMaker, Microsoft Excel, Word Perfect, Dataease and as many as 80 other programs. And using the DESQview API, be able to dynamically link them.

More bang; less bytes

While other programs get bigger, we've worked to make DESQview smaller. And we've succeeded in a big way on PCs and PS/2™s with extended, EMS 3.2 (AboveBoard), EEMS and EMS 4.0 memory—as well as on 386 PCs and



DESQview lets you run your favorite programs in windows side-by-side.

PS/2s. For example, DESQview overhead on EMS 4.0 and 386 PCs can be as low as 10K on EGA/VGA PCs. And DESQview actually increases memory 30K on CGA PCs; 20K on monochrome and Hercules PCs. That's good news for users of big desktop publishing, CAD and database programs.

Introducing DESQview 386

For users of 80386 PCs and PS/2s (or PCs with 80386 add-in boards, such as the Intel Inboard 386), there's DESQview 386 (a combination of DESQview 2.2 and the new QEMM-386

Quarterdeck Expanded Memory Manager, version 4.2).

DESQview 386 gives you extraordinary power. Run text, CGA, EGA, VGA, and Hercules programs in windows and in the

background. Run 32-bit 386 programs, like Paradox 386, and IBM Interleaf simultaneously with your favorite DOS programs. All with the speed and performance you expect out of your 386. And with protection against 'misbehaved' programs.

Promise and performance

And, of course, both DESQviews have all the features that made prior versions the popular choice in operating environments. The ability to multitask in 640K and beyond. View programs in windows or full screen. Transfer data. Access DOS via menus. Dial your phone. And create key-stroke macros within and between programs.

Our story gets better and better

If there's any doubt about our commitment to your PC and PS/2 productivity, just look at our accomplishments over the years. We think you will understand why GE, Ford, Aetna, Monsanto, and so many other major corporations use DESQview.

And why PC Magazine twice gave DESQview its Editor's Choice Award for "The Best Alternative to OS/2," why readers of InfoWorld voted DESQview "Product of the Year" three times. Why, by popular vote at Comdex Fall for two years in a row, DESQview was chosen "Best PC Environment" in PC Tech Journal's Systems Builder Contest, and just won their "Professional Solutions" Award.

DESQview lets you have it all now.



Quarterdeck Delivers.

QEMM. Break the 640K barrier for \$59.95

Your 80386 PC, IBM Personal System/2 Model 80, PC or AT with 80386 add-in board, as well as your IBM Personal System/2 Models 50 or 60 can all break through the DOS 640K barrier. Now you can have maximum use of your memory—whether you have one megabyte or 32—with the Quarterdeck Expanded Memory Manager. All without having to purchase special expanded memory boards.

QEMM uses hidden features within your existing memory to make it compatible with the Lotus-Intel-Microsoft Expanded Memory Specification (EMS) version 4.0.



Now you can run colossal spreadsheets, databases, and CAD models designed for expanded memory, using Lotus 1-2-3, Symphony, Framework, Paradox, AutoCAD, Excel and more.

And if you'd like to use these programs all together—multitasking beyond 640K—QEMM works with our popular DESQview multitasking environment.

If you are one of the 12 million or so 8088, 8086 or 80286 PC users who feel left out, don't despair. We have options that let you keep your computer and favorite programs and give you today what the newest PCs and operating systems are promising for the future.

Visit your dealer for more information on barrier-breaking Quarterdeck products.

DESQview API Toolkit. New C and Pascal Libraries, Debugger, Panel Designer. And more.

DESQview API
Conference '89
Coming in August
Write for details

API Reference Manual

The key to the power of the DESQview API, our Reference Manual contains all you need to know to write Assembly Language programs that take full advantage of DESQview's capabilities. And there's an 'include' file with symbols and macros to aid you in development.

API C Library

Here are C language interfaces for the entire set of API functions. It supports the Lattice™ C, Metaware™ C, Microsoft® C, and Turbo C compilers for all memory models. Included with the C Library package is the API Reference Manual and source code for the library.

API Pascal Library **NEW!**

The Pascal library provides interfaces for the entire set of API functions. It supports Turbo Pascal V4.0 and V5.0 compilers. Included are the API Reference Manual, source code for the library, and example programs.

API Debugger

The DESQview API Debugger is an interactive tool enabling the API programmer to trace and single step through API calls from several concurrently running DESQview-specific programs. Trace information is reported sym-

bolically along with the program counter, registers, and stack at the time of the call. Trace conditions can be specified so that only calls of interest are reported.

API Panel Designer

This interactive tool helps you design windows, menus, help screens, error messages, and forms. It includes an editor that lets you construct an image of your panel using simple commands to enter, edit, copy, and move text, as well as draw lines and boxes. You can then define the characteristics of the window that will contain the panel, such as its position, size, and title. Finally, you can specify the locations and types of fields in the panel.

The Panel Designer automatically generates all the DESQview API data streams necessary to display and take input from your panel. These data streams may be grouped into panel libraries and stored on disk or as part of your program.

More Tools are Coming

Quarterdeck is committed to adding tools as needed by our users. To that end we have been working with Ashton Tate and Buzzwords International on dBASE III and dBASEIV translators. And in the works, we have BASIC and DOS Extender libraries.

Quarterdeck

Quarterdeck Office Systems, 150 Pico Blvd., Santa Monica, CA 90405 (213) 392-9851
FAX: (213) 399-3802

For additional information, please use the following Reader Service numbers: DESQview: # 234 QEMM: # 235 API Tools: # 236 API Conference: # 237

NO ADDED CHARGE ON CREDIT CARDS

FOR COMPUTER & ACCESSORIES

CALL TOLL FREE: 1-800-882-2802

FOR FAX, TYPEWRITERS & DICTATION EQUIPT.

CALL TOLL FREE: 1-800-223-7323

IN N.Y. STATE CALL: 1-212-947-5290

HOURS: Mon. Tru. Thurs. 9AM Till 6PM, Fri. 9AM Till 1:30PM, Sun. 9:30AM Till 5PM, Closed On Sat.

EXECUTIVE

PHOTO & SUPPLY CORP.

LAPTOPS



mp286L
80286-12MHz, 640K, 20MB Hard Drive, 1-3.5 1.44 Drive, 11" Black on White Display

2359.75

286L w/40MB Hard Drive... CALL

SPARK by Dataview
Spark-EL, 640K, 2-3.5 Drives... 987.00
Spark 1-Floppy Drive, & 1-20MB H.D. 1769.95
1200 Model 1/Dataview... 149.75

EPSON

EQUITY LT w/2-Drives, Backlit Screen & Laplink Plus... 1045.00
EQUITY LT w/20MB H.D.... 1487.00*

TOSHIBA (sold in Store Only)
T-1000... CALL T-1200/FB... CALL
T-1200HB... CALL
NEW! T-1600... CALL
NEW! T-5200... CALL
T-3200/T-5100... CALL

ZENITH

184-1... 1439.00 184-2... 2147.75
Supersport 286 Model 20 w/20MB Hard Drive... 2965.75
286 w/40MB Hard Drive... 3367.75
386 w/40MB Hard Drive... 4199.75

NEC

PROSPEED 386... CALL
ULTRALIGHT... CALL
MULTISPEED HD... CALL

SHARP

PC-4502 w/640K, 2-Floppy Drives & Backlit Monitor... 919.75

*Price after mfr. rebate
Up To \$200

DESKTOPS



DESKPRO 286, 12MHz, 1.2 Floppy Drive, Seagate 40MB Hard Drive (40ms) 2065.00
COMPAQ SLT/286 Portable w/40MB Hard Drive... CALL



AST PREMIUM 286
10 MHz, 512K, 1.2 Floppy Drive, Seagate 40MB Hard Drive (40ms)

1597.75

NEW! AST BRAVO 286 8 MHz, 1.2 Floppy, 40MB Hard Drive (40ms)... 1257.00

EPSON
EQUITY 1+... CALL

COMPATIBLES
IBM-XT Compatible, 1-360 Floppy Drive, 1-20MB Hard Drive... 725.00
IBM-AT Compatible, 12MHz, 512K, 1.2 Floppy Drive, Seagate 40MB Hard Drive (28ms)... 1219.00
VENDEX Headstart II... CALL

World Accessories
WORLD PORT 2400 Modem/Fax CALL
DICONIX Portable Printer... 299.75

PRINTERS



EPSON LQ-500
24 Pin, Narrow Carriage
180 CPS Draft, 60 CPS NLQ,
Tractor Feed Included

CALL

New LX-800... CALL EX-800... 369.75
LQ-850... CALL LQ-950... CALL
LQ-1050... CALL LQ-2550... 929.75
FX-850... 339.75 FX-1050... 449.95

PANASONIC
KX-P 1191, 222.50 KX-P 1181, 175.75
KX-P 1124... Low Price
PANASONIC Laser Printer... 1277.00

TOSHIBA (Sold in Store Only)
NEW! Expresswriter 311... CALL

NEC
NEC 2200... 339.00
NEC P5200... 499.95
NEC P5300... 649.95
NEC P9... 399.00
NEC LC-890 Postscript Laser... 3089.00

OKIDATA
OKIDATA 320... 339.00
OKIDATA 390... 469.95
OKIDATA 393... 1019.00

STAR
NX-1000... 169.90 NX-1000C... 189.00
NX-1000 Rainbow... 229.00

PRINTER SALE!
NEW! H.P. Deskjet... CALL
H.P. Laserjet II w/Toner... CALL
APPLE Imagewriter II... 439.00

HARDWARE



INTEL 80287-8... 205.00
NEW! INTEL Above Board Plus... 396.00
NEW! INTEL 386PC Piggyback w/1MB... 257.00
NEW! INTEL Visual Edge... 429.00
AST Rampage Plus... 399.75
Laser Connection Jetscript... 1635.75
NEW! Logitech Mouse... 84.95
NEW! Logitech Scanman... 189.00
DFI HS-3000 Scanner... 189.00
HP Pro Collection... 235.00
IO Engineering Cartridge... 375.00
MICROSOFT Mach 20... 315.75
MICROSOFT Mouse... 99.95
PLUS 20MB CARD... CALL
TOSHIBA 3 1/2" 720K Drive w/Kit... 85.00

Display Cards & Monitors
PARADISE VGA Plus... 253.75
NEW! PARADISE VGA Plus 16... 299.90
PARADISE VGA Professional... CALL
NEW! HERCULES VGA Card... CALL
ATI VGA Wonder 256K... 277.00
NEW! NEC Multisync IIA Monitor... CALL
NEC Multisync 3D... 659.75
ZENITH Perfect Monitor... CALL
SEIKO 1430 Monitor... 597.00
SONY 1302 Monitor w/Stand... 659.00
SONY 1320 VGA Monitor... 499.00
PRINCETON Ultrasync... 492.00

Modems/Fax Cards
New! HAVEL Personal Modem... CALL
EVEREX 1200B Modem... CALL
US Robotics 9600... 679.75
EVEREX Fax Card... 297.00
COMPLETE PC Fax 4800... 235.00
QUADRAM Jt Fax Internal 4800... 179.00

DISKETTES
maxell MD2-100

MAXELL MD-2D... 9.49
MAXELL MD2-HD... 18.99
MAXELL MF2-HD 1.44... CALL

SOFTWARE

WORDPERFECT... 224.95
AVERY List & Mail... 37.95
NEW! SAMNA AMI... CALL
NOTA BENE 3.0... 235.00
XY Write w/Al Carte... 215.95
WORDSTAR Legal... 249.95
WORDSTAR Pro... 184.79
GRAMMATIK III... 48.99
LASER GO... CALL
MATH CADD... 197.00
ADOBE Fonts... CALL
BITSREAM Fonts... CALL
PER: FORM by Delorina... 139.00
MICROGRAFX Designer... 425.00
XEROX Prof. Extension... 374.00
ALDUS Pagemaker... 445.00
HARVARD Graphics... 268.75
LASER Torq... CALL
ZENOGRAPH Pixie... 107.95
PFS First Publisher... 69.00
PROCOM Plus... 42.95
SMARTCOM III... 139.00
NEW! LUCID 3D... 59.00
LOTUS 1-2-3... CALL
LOTUS Agenda... 247.75
Q & A... CALL
ASK Sam... 165.00
D'Base IV... CALL
DATEASE 4.0... CALL
FOXBASE Plus... 187.75
PARADOX 3.0... CALL
FRAMEWORK III... 399.00
INTUIT Quicken... 31.95
DAC Easy Accounting 3.0... 57.00
SOLGOM Basic Accounting... 149.95
ONE Write Plus... 125.00
NO! Will Maker... 30.95
FASTBACK Plus... 97.00
SPINRITE... 48.99
386 MAX... 54.75
SPINAKER Resume Kit... 32.00
TRAVELING Software Viewlink... 89.95
FLASH 8.0... 36.95
NORTON Advanced Utilities... 77.75
SYSTEM Sleuth... 84.95
BORLAND Turbo Pascal... 93.50
BORLAND Turbo C... 93.50
MACE Nvelope... 26.95
BLOCK Personal Lawer... 34.95
DESKVIEW... 75.00

FAX MACHINES



PANAFAX
UF-140... CALL UF-150 IN STOCK
UF-250 IN STOCK UF-260 IN STOCK

SHARP
FO-220... CALL FO-300... CALL
FO-330... CALL FO-420... CALL
FO-550... CALL FO-700... CALL

CANON FaxPhones



FaxPhone 8... CALL FaxPhone 15... CALL
FaxPhone 20... CALL FaxPhone 25... CALL
FAX 1100... CALL FAX 225... CALL
FAX 270... CALL FAX350... CALL
FAX 630... CALL FAX 705... CALL

RICOH
FAX-25E... CALL FAX-35... CALL
FAX-65E... CALL FAX-75E... CALL

MURATA
M-1200... 599.90 M-1600... 699.90

PANASONIC
KX-F 100... CALL KX-F 120... CALL

TOSHIBA Price Break
3300... 959.90 3700... 1199.90
Model 30100... 759.90
NEW! 3600... CALL

SANYO
515H... IN STOCK SF-200 IN STOCK

BROTHER
FAX 60 w/Answering Machine... 759.90
FAX 175... CALL

FAX PAPER
8 1/2"x9" 49.95 8 1/2"x14" 59.90
8 1/2"x32" 74.95
FAX Cleaning Kit... 29.95

TYPEWRITERS & Word Processors



SMITH CORONA
PWP-40IN STOCK PWP-80IN STOCK
NEW! PWP-100... IN STOCK
XL-1000 Typewriter... Special 99.90
XL-2500... 135.95 XD-5500... 159.95
XD-7500... 209.90 XD-9500... CALL

PANASONIC



KX-W 1500 Word Processor... IN STOCK
KX-R 320... CALL KX-R 330... CALL
KX-R 340... 184.90 KX-R 350... 219.90

BROTHER



WP-55 Word Processor... IN STOCK*
NEW! WP-490... CALL
AX-26... CALL AX-28... CALL
*Free Spreadsheet Program w/Purchase of WP-55 Word Processor

Dictation Equipment



OLYMPUS Pearlcorer
L-200... 129.90 S-907... 35.90
S-911... 59.90 S-930... 99.90
T-1010 Transcriber... 169.90
S-902... 119.95 S-810... 179.95
T-100... 289.95 T-2020... 229.90

PANASONIC

RN-15... 129.90 RN-36... 179.90
RN-89... 79.90 RN-105... 29.90
RN-115... 39.90 RN-125... 53.90
RR-900... 179.90 RR-970... 249.90
RR-980... 279.90

SANYO

TRC-6100... CALL TRC-5680... 79.90
TRC-2550... 149.90
TRC-5200... 229.90 TRC-5020... 179.90
TRC-4300... 227.90 TRC-4030... 179.90
TRC-8000A... 227.90 TRC-8010A... 165.90
TRC-8700... 239.90 TRC-8070... 185.90
TRC-9100... 239.90 TRC-9010... 199.90

SONY

M-100B... 219.90 M-740... 35.90
M-750V... 49.90 TM-5000EV... 39.90
BM-12... CALL BM-107... CALL
BM-560... CALL BI-500... CALL
BM-75... CALL BM-80... CALL
BM-815T... CALL BM-820... CALL

NORELCO

585... 99.90 592... 119.90
NT-11e... 134.95 NT-V... 199.95
NT-VI... 219.90 NT-VII... 247.90
MC-III... 164.95 MC-IV... 199.95
2595... 119.90
205... 287.90 505... 319.90
510... 399.90 805... 629.90
MC-3000... 299.90 MC-4000... 379.90
2505... 399.90 2510... 334.95

COPIERS



Canon
PC-3 II... 433.90 PC-5 II... 519.90
PC-5L II Legal Size... CALL
PC-6... CALL PC-6RE... 869.90
NEW! PC-7 Zoom Copier... 939.90
Black Cartridges... 79.95
8 1/2"x11 Paper (5000 sheets)... 49.50

CALCULATORS & DATABANKS

HP HEWLETT PACKARD
HP-108B Business... 38.45
HP-12C Financial... 59.90
HP-14B Business... 58.90
HP-17B Business... 75.90
HP-19B Business Consultant II... 125.90
HP-20S Scientific... 39.90
HP-22S Algebraic Scientific... 43.90
HP-27S Scientific... 74.95
HP-28S Advanced Scientific... 162.90
HP-32S RPN Scientific... 52.95
HP-41CV... 119.90 HP-41CX... 169.95
HP-42S RPN Scientific... 88.90
HP Infrared Printer... 99.90

PSION

ORGANISER II-XP... 198.90

SHARP

OZ-7000 WIZARD... IN STOCK
EL-1197 IV 10-Digit Tax Function... 49.90
EL-2197 12-Digit Tax Function... 57.90
EL-6230 Auto Dialer... 39.90
EL-6250H Dial Master... 53.90

CASIO

SF-3000/18K Digital Diary... 69.90
SF-4000 32K Digital Diary... 89.90
IF-8000 Digital Diary... 109.90
NEW! SF-7500 Digital Diary Clock/189.90

TELEPHONES



Panasonic
Feature Telephones
KX-T 2335... 32.00 KX-T 2365... 55.90
Multi-Line Phones
KX-T 3122... 56.90 KX-T 3145... 67.90
KX-T 3155... 75.90 KX-T 3170... 139.90

INTEGRATED PHONES

KX-T 2385... 62.90 KX-T 2630... 105.90
KX-T 2429... 135.90 KX-T 2430... 108.90
VA-8045... 149.90

Answering Machines Specials

KX-T 1423... 85.90 KX-T 1418... 69.90
KX-T 1427 LCD w/Time Announce... 109.90
KX-T 1600... 69.90 KX-T 1720... 109.90

CORDLESS PHONES

KX-T 3000... 119.90 KX-T 3807... 59.90
KX-T 3823... 70.90 KX-T 3824... 89.90
KX-T 3832... 93.90 KX-T 3880... 125.90
KX-T 3900 w/2-Keypads... 129.90
KX-T 4200 w/Answering Machine... 149.90

Freedom Phone

FF-1700 Cordless "Top Rated" 109.90

Business Key Systems PANASONIC

2 Line Integrated Intercom System
VA-9200 System (1-9210, 2-9230) 369.90
VA-9210 Electronic Controller... 124.90
VA-9230 2-Line phone w/Speaker/124.90
VA-61410 Key Service Unit... CALL
VA-61421 Phone w/Speakerphone... CALL
VA-61422 Speakerphone w/LCD... CALL
VA-61423 Speakerphone w/BLF... CALL
VA-208 2-Line System... CALL
VA-20812 System Unit... CALL
VA-20821 Phone w/Speaker... CALL
KX-T616 6-Line System... CALL
KX-T61620 Phone w/Speaker... CALL
KX-T61630 Speakerphone w/LCD... CALL
FREEDOM PHONE
FS-246 6-Line Service Unit... CALL
FS-800 Basic Station... CALL
FS-900 Executive Station... CALL

VISA, MASTERCARD, AMERICAN EXPRESS, OPTIMA & DISCOVER CARDS ACCEPTED

OUR GUARANTEE: Defective goods will be replaced or repaired if returned within 10 Days in original packing, mint condition, blank warranty card, detailed letter of explanation & copy of invoice. No return privilege on software. If found defective, We will advise customer how to consult manufacturer for warranty service. For Customer Service: Please Call (212) 947-5295. Not responsible for typographical errors. We reserve the right to limit quantities. TO ORDER BY MAIL: Please send money order or certified check for UPS shipment on most items. Personal check delays your order by 15 days.

Shipping & Handling: Handling Charge; 2% plus 5.95. Shipping Charge; 0.65 per lb. Estimate minimum shipping 5.95. Total charge at time of order. Shipping & Handling charges are non refundable. INQUIRE about NEXT DAY AIR or 2nd DAY AIR Shipment. N.Y. State Residents add TAX.

MAIL ORDER: Dept BY, 120 West 31st Street, N.Y., N.Y. 10001 (Tel. 1-212-947-5290)

MANHATTAN STORE: 120 West 31st Street, N.Y., N.Y. 10001 (Tel. 1-212-564-3592)

SCARSDALE, NY STORE: 455 Central Ave. (Scarsdale Plaza) SCARSDALE, N.Y. 10538 (Tel. 1-914-723-1331)

N.Y.C. Consumer Affairs License Number: 800193

Circle 329 on Reader Service Card





THEN AND NOW IN WORD PROCESSING

New developments in Mac word processing bode well for users of other computer systems, too

Back half a dozen years ago, when MS-DOS was still slugging it out with CP/M and the Macintosh was but a mere rumor, word processing was fraught with peril for the unsuspecting user.

Software reviewers had to warn their readers about products like the original release of Perfect Writer, which required that paragraphs be separated by blank lines. If you merely indented your paragraphs without adding an extra carriage return between them, the program would happily reformat your document into one big, undifferentiated glob of text. It also had a spelling checker that would accept "nosai" and "nosation" as legitimately spelled words derived from "nose."

Then there were those ghastly "page-oriented" word processors. Once you typed past the bottom of page 1, your goose was cooked. If you went back and decided to add something, the resulting extra lines wouldn't push their way onto page 2; you had to remember to highlight the excess and move it to the top of the next page.

These types of products were fine for a limited set of projects, but you had to match your requirements to product specifications with extreme care. Nowadays, there's no longer much need for the same sort of vigilant zeal. I haven't seen a truly horrendous word processor in a year or two. Almost every available program performs the essential functions with little hassle.

There are some programs I don't like, and sometimes I can't understand why a manufacturer has brought an undistin-

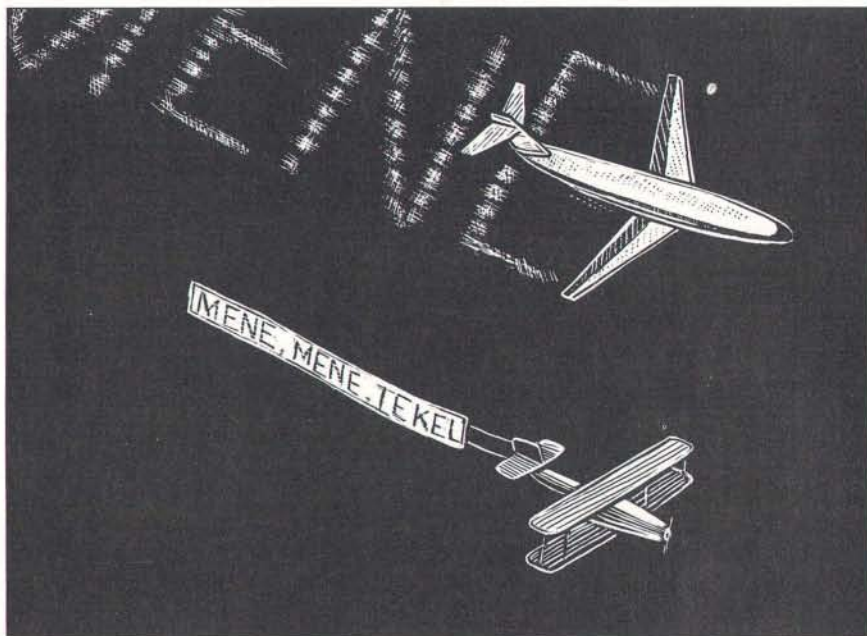

guished product to market, but it has been a while since I've felt the urge to drive a digital stake through a word processor's binary heart. I have no qualms about telling an MS-DOS user to go out and buy any of the best-selling products—WordPerfect, WordStar, Microsoft Word, XyWrite, PC-Write, Sprint, Q&A Write, and so forth. There are excellent choices among the integrated packages—Framework, Enable, and Smart, for instance. Some lesser-known programs, like Celebrity and Nota Bene, are also good choices. I'll hold my remarks on Mac software for a moment, but again, most of the programs do provide basic functionality.

My recommendation to a total novice would be to go to a retailer, compare lists of features on product boxes, spend a few minutes watching demonstrations of those programs that claim to do what you want to get done, and then go with your gut feeling. You don't have much chance of making a terrible mistake.

It's slightly complicated to advise a more sophisticated user, simply because the reasons for selecting one product over another one are now largely determined by comparing specific features for specialized functions or by defining intangibles like "feel." In the IBM PC-compatible arena, I'll suggest Lotus Manuscript for its handling of technical documents, XyWrite for nifty macro programmability, Sprint for the ease with which you can reconfigure its command set, and WordPerfect for the overall sense of well-being it gives its users. Other programs, of course, answer other demands. Even at this level, it's difficult to blow it completely. You can still get things done, even if it's a tad more awkward with one program than it might be with another.

Why have we reached this amazing state of grace? There are two reasons. First, programmers and users alike have been slogging away at microcomputer

continued

CAD Warehouse, Inc.
8229 E. Washington Street
Chagrin Falls, Ohio 44022

**800
289-1650**

"PAN OVER FOR SUPER PRICES"

**CADD Workstations
featuring EVEREX STEP Series Computers**

Each system fully configured including 2 Serial Ports, 1 Parallel Port, corresponding Math CoProcessor, Enhanced "AT" 101 Keyboard, DOS 3.3, and GW-Basic. Each system thoroughly tested prior to shipment and supplied with a 1-Year "On-Site" Warranty !!!

EVEREX STEP	CACHE	40 MB MFM	80 MB MFM	160 MB ESDI	300 MB ESDI
386/25 w/4MB	64KB	\$7328	\$7570	\$8458	\$9490
386/25 w/2MB	128KB	5992	6273	7094	8127
386/20 w/4MB	64KB	6079	6318	7247	8273
386/20 w/2MB	128KB	4999	5150	5961	6972
386/16 w/2MB	128KB	4290	4532	5399	6411
286/20 w/2MB	—	3487	3726	4686	5615
286/16 w/2MB	—	3121	3359	4287	5218
286/12 w/1MB	—	2452	2687	—	—

Monitors & Card Combo's

Graphics Card with:	Mitsubishi 19" HL6905	NEC XL Multisync	Hitachi 19" CM2085	Nanao 16" 9070S	Hitachi 15" HM Series
Artist XJ10	\$4471	\$4332	\$4061	\$3000	\$3320
Artist XJ10 w/VGA	4939	4821	4524	3463	3782
Artist 12/256	5818	—	5393	—	4651
Verticom HX-16 w/VGA-16	4144	4030	3737	2676	2996
Metheus 1104	4481	4366	4072	3010	3330
Metheus 1128	3449	3339	3050	1989	2308
VMI-1024/256	4160	4047	3754	2693	3012
VMI-Cobra/16	5269	5149	4850	3789	4108
Photon 1000+	4679	4563	4267	3206	3525
Photon 2048-50	3468	3358	3069	2008	2327
#9 SGT Plus	4519	4403	4108	3047	3366
Monitor Only	2470	2350	2075	1036	1345

Digitizers

Calcomp	
12 x 12 4-Button	\$ 345
12 x 12 16-Button	345
12 x 18 4-Button	732
36 x 48 16-Button	3850
Summagraphics	
Sketch + 12 x 12	\$ 345
12 x 18	658
36 x 48 16-Button	3889
Kurta	
12 x 12 4-Button	\$ 389
12 x 17 4-Button	633
Cordless Puck Add	33
36 x 48 16-Button	3035
Hitachi	
Puma 12x12	
4 or 12 Button	\$ 399
Tiger 12 x 12 12-Button	599
36 x 48 16-Button	3872
GTCO	
11 x 11 DPC 4-Button	\$ 552
24 x 36 DPC 4-Button	2173
36 x 48 DPC 4-Button	2669

The above is a partial listing of our product line. Please inquire if you're interested in a product not listed. Prices subject to change without notice.

- * Shipping limited to Continental U.S.A.
- Quoted prices reflect a 2% cash discount.
- C.O.D., VISA, and Mastercard accepted.
- Rated companies call for terms.
- All manufacturers' warranties apply.

***** CADD BUSTER *****

EVEREX STEP 386/25 with 2MB SIMM, 387-25 Math Coprocessor, 1.2MB Floppy, 80 MB Hard Drive, 2 Serial, 1 Parallel Port, Keyboard, DOS 3.3 and GW-Basic with your choice of either Graphics Card: Artist XJ10 - Dual Verticom HX16 - VGA(8) attached to a Hitachi 19" Multisync Color Monitor with your choice of digitizer: Calcomp 12 x 12 4-Button/Stylus Calcomp 12 x 12 16-Button SummaSketch Plus and a: Calcomp 1023 Artisan A-D 8 Pen Plotter
*** Fully configured and ready to run ***
\$ 14,350.00 -- DELIVERED *

Plotters

Calcomp	
1023 Artisan	\$3725
1043 - GT	5450
Houston Instruments	
DMP - 61	\$3545
DMP - 62	4445
Multi Pen Option	565
Ioline	
3500 A-D 1 Pen	\$2430
3700 MP	3499
4000 MP	4422
Roll Feed Option	148
Hewlett Packard	
ALL Models	CALL

word processors for more than a dozen years now, and we have all reached a tacit consensus on what the fundamental operations are and how they should be implemented.

Second, I think we've hit the natural limit of what a single user can do with 640K bytes of RAM and a 25-row by 80-column text-only display. (I'm discounting the possibilities of hypertext access to reference sources, network support, and AI-based grammar checking, but I see these options as peripheral to the primary business of pounding out words.)

However, as pleasant as this moment of peace may seem, it will be relatively short-lived. Higher-resolution output devices (e.g., laser printers) and the related hunger for desktop publishing tools are rapidly pushing word processing into a new stage of graphics orientation. Better output has made yesterday's concept of WYSIWYG nearly obsolete.

Even if you're not interested in creating newsletters with your word processor, wouldn't it be nice to see what your document will look like without having to enter a special preview mode? If there's a next generation of personal computing in the wings, this factor alone could be enough to drive the changeover.

Coming Attractions

For better or worse, the future of word processing is currently being played out on the Mac, although the focus may shift in time to the Presentation Manager or some windowing form of Unix. Many developers see the Mac as an ideal testing lab for products or concepts they hope to port to other environments. Why? The Mac already has an acceptable graphics interface and seamless access to oodles of RAM, that's why. Thus, watching the word processing wars on the Mac is an entertaining and important spectator sport, even if you never intend to have anything to do with any computer bearing an Apple logo.

In its early days, the Mac was a terrible machine for word processing vendors. MacWrite, a utilitarian program at best, was given away with every computer sold. Even mighty Microsoft couldn't break this stranglehold; my spies in Redmond tell me that during the Age of Bundling, Microsoft Word never achieved more than a 30 percent share of the market for Mac word processors. Few other software developers bothered to think about invading Apple's turf; Mac word processing lay stagnant.

But today, with MacWrite stripped away and desktop publishing acting as a motivating force, word processing devel-

opment has begun to heat up. The Mac now boasts a wide panoply of editors, representing quite divergent strategies for survival in the graphical universe.

I've been concerned because this opening up of the market has resulted in "kitchen-sink" word processors, ones that have followed the traditional micro-computer path of creeping featuritis. Microsoft Word and Ashton-Tate's FullWrite Professional are the leading representatives of this approach, boasting a huge number of features. They're impressive but cumbersome, having sprouted many elements of layout programs without borrowing desktop publishing's paste-up metaphors.

Coming from the opposite direction, a second group of products is comprised of the page-layout programs that have evolved into word processors, including Quark XPress, Ready-Set-Go!, and Ragtime. PageMaker remains unique among these products in that it has not added word processing features.

However, three recent programs have given me some hope that there's room for other paradigms.

A Nifty New Entry

First, there's Nisus, a full-featured word processing powerhouse from Paragon Concepts. [Editor's note: See Don Crabb's *Macinations* column in the May BYTE.] Nisus is a direct descendant of the company's top-notch programming editor, Qued/M, but Paragon Concepts has done a lot more than merely bolt on typeface controls. Although there are familiar overtones, this word processor is a much bigger and spiffier product, about four times the size of its progenitor.

There are many unique features, but the two most obvious are found in the program's search-and-replace and macro functions. Nisus contains a thorough implementation of the Unix `grep` command, with which you can locate not only words and phrases, but also non-printing characters, type attributes, tightly specified character patterns, and physical locations within a file. You can write search expressions in the cryptic `grep` "language," or you can opt for Nisus's Easy-`grep` commands, which let you build your search parameters by selecting items from pull-down menus, much like some of the query systems available in database managers.

Coupled with macros that can be generated either by having the program follow your actions as you work or by editing code in a macro file, you wind up with more precise control of editing operations than in any other Mac word pro-

cessor. The program comes with over 80 macros already installed, ranging from simple operations like transposing words all the way to a full mail merge that will extract variable data from an independent text file.

Although Nisus doesn't have style sheets per se, you can create macros that accomplish the same thing. These macros can prompt for user input, peel data from desk accessories or any of Nisus's 10 clipboards, set and remove markers, and manipulate the Mac file system, which puts a pretty incredible set of tools at your disposal.

Other features include a 32,000-level "undo" stack, multiple columns, the

For better
or worse, the future
of word processing is
currently being played
out on the Mac, but
this focus may shift.

slickest draw mode I've seen in a text editor, file comparison with synchronized scrolling, a Merriam-Webster dictionary and thesaurus, and a reduced-size preview mode for adjusting page setup.

Nisus also offers search-and-replace capability throughout a list of unopened files, automatic backup, and an information command that gives not only word and character counts, but two readability indexes as well. That's only a partial list; there's a lot more to the program. It's also fast.

Since this is a new product, there are still some rough edges; there's no easy way to print out your macro file, and I've noticed some jumpiness at the bottom of the screen occasionally. There are a few more trivial glitches, but this is rapidly becoming my favorite Mac editor.

And on Your Right . . .

If you don't need the `grep` or the macros of Nisus, you would do well to check out T/Maker's WriteNow for Macintosh 2.0, which is now a fully mature product. In its first incarnation, I wasn't particularly impressed with WriteNow. It added a spelling checker, multiple columns, and

better font sizing and leading (line spacing) to the basic MacWrite model, but not much else. However, at this point, I'd argue that WriteNow is the leader in its price range. In the category of lower-priced, relatively simple Mac word processors, this is the program to beat.

My favorite new feature is WriteNow's global style-change command. You select a region of text, starting with the first example of the type attributes you want to modify. Any changes you make affect the first paragraph in the block and any other paragraph with identical formatting. This isn't quite a style sheet, but it's close enough.

And WriteNow is as good as—or better than—any comparable program at letting you set up your document for printing, with headers, footers, footnotes, odd/even binding margins, smart quotes, and the like. The program is quick and stable. Also, what you see on-screen is invariably what you get when you print documents. It accepts huge files, understands all the keys on an extended keyboard (something that Nisus doesn't do), allows conditionals in mail merge, and does everything with notable rapidity.

Son of Word Processing

Finally, there's Preferred Publishers' Vantage, a word processor in the guise of a desk accessory. It's an enhanced version of McSink, a shareware desk accessory designed for preprocessing text for page-layout work. McSink lets you massage data left on the Clipboard and then repastes it into the original document in the foreground application. Vantage adds true word processing, spelling checking, and file handling to this model.

In some ways, Vantage represents a handy subset of Nisus. It comes with a long list of macro-like functions that enable you to sort, number lines, insert prefix and suffix strings, change case, adjust line length, convert tabs to spaces and back, strip control characters, and add or delete linefeeds. There are true macros, too; although you can't create them by turning on a recorder, you can write your own miniprograms and save them as loadable macro files.

Vantage may be a harbinger of the lean, mean programs we might see when the Mac gains true multitasking and data exchange. A nice little word processor, it makes a wonderful adjunct to other sorts of programs that require text input.

Better Choices Are Here

What I really like about these three programs is that they are all nicely designed

continued

American Power Machines

GRUMMAN F-14A TOMCAT (1972)

This two-seat carrierborne fighter has an advanced radar that can simultaneously track 24 targets and direct attacks against any six of them at a distance of up to 100 miles.

SPECS. 80386

- True Intel 25MHz CPU
- 25MHz Chips & Technology Neat Set
- Deluxe, Digital Tower Chassis/230 Power Supply
- 1MB RAM (640k Base, 384k ROM Shadow)
- 8 I/O Slots (1 32 Bit, 4 16 Bit, 3 8 Bit)
- 1.2 MB F.D.D.
- 1.44 MB F.D.D.
- 150 MB Maxtor ESDI Hard Disk Drive (17 MS)
- 14" Flat Screen Monochrome Monitor & Card
- Serial/Parallel Ports
- 101 Keyboard
- Motherboard Expandable to 8MB/16MB max.

25 MHz

Tower 386 DX-T

\$3,899



SPECS. 386-20 MHz

- True Intel 20 MHz CPU
- 1 MB RAM (640 K Base, 384 ROM Shadow)
- 8 I/O Slots (1 32 Bit, 4 16 Bit, 3 8 Bit)
- 1.1 Interleaved Hard/Floppy Controller
- 1.2 MB Floppy Disk Drive
- 1.44 MB Floppy Disk Drive
- 80 MB Seagate Hard Disk Drive
- Serial/Parallel Ports
- 14" Flat Screen Monochrome Monitor & Card
- 101 Keyboard

\$2,699

SPECS. 386-20 MHz Gas Plasma Portable

- Deluxe 4 Shade Gas Plasma
- 640 x 400 Resolution
- True Intel 80386-20 MHz CPU
- 1 MB RAM (640 K Base, 384 K ROM Shadow)
- Motherboard Expandable to 8 MB
- 1.2 MB Floppy Disk Drive
- 40 MB, 28 MS Hard Disk Drive
- Serial/Parallel Ports
- 80387 Socket
- 3 Expansion Slots Available
- 20 Lbs. with Carrying Case
- RGB/MGP Ext. Output, Ega Optional

\$2,999



OPTIONS:

EGA CARD & MONITOR ADD..... **\$350.00**

VGA CARD & MONITOR ADD..... **\$499.00**

64 K CACHE OPTION ADD..... **\$475.00**

CALL FOR LATEST MEMORY UPGRADE COSTS. ALL SYSTEMS FULLY MS, PC DOS COMPATIBLE. RUNS UNIX PC MOS, PIC, NOVELL AND OS/2 MULTI-USER OPERATING SYSTEMS. SYSTEMS MAKE EXCELLENT FILE SERVERS OR HIGH END WORK STATIONS.

SUBSTANTIAL DISCOUNTS FOR VOLUME BUYERS.

MICRO TELESIS

INCORPORATED

1260A Logan Ave., Ste. A2
Costa Mesa, CA 92626

(714) 557-2003 Fax: (714) 557-9729

ITEMS DISCUSSED

Nisus\$395
Paragon Concepts, Inc.
990 Highland Dr., Suite 312
Solana Beach, CA 92075
(619) 481-1477
Inquiry 1021.

Vantage \$99.95
Preferred Publishers, Inc.
5100 Poplar Ave., Suite 617
Memphis, TN 38137
(901) 683-3383
Inquiry 1022.

WriteNow for Macintosh 2.0\$195
T/Maker Co.
1390 Villa St.
Mountain View, CA 94041
(415) 962-0195
Inquiry 1023.

for writing; the page-layout and formatting mechanisms don't get in the way of the primary task. They all make good companions to desktop publishing software packages, as well as standing admirably on their own.

It's becoming obvious that the Mac environment, once so poor in word processing, will eventually have a constellation of programs that rival those in the IBM PC-compatible sector in richness and personality, if not in quantity. That's good news for writers who like the Mac.

By extension, the better news is that the coming era of windowing interfaces will not reduce everyone else to using countless clones of early MacWrite, as I certainly once feared when I first looked at those clumsy editors provided with Microsoft Windows and Digital Research's GEM. I'm positive that we'll be using the products I mentioned, or ones much like them. What this means is that we'll be able to select word processing programs that accurately reflect our habits and preferences from a decent array of choices. This is very good news indeed for all of us. ■

Ezra Shapiro is a consulting editor for BYTE. You can contact him on BIX as "ezra." Because of the volume of mail he receives, Ezra, regretfully, cannot respond to each inquiry.

Your questions and comments are welcome. Write to: Editor, BYTE, One Phoenix Mill Lane, Peterborough, NH 03458.

1024X768 IBM COMPATIBLE VGA VIDEO CARD

VGAWONDER™

T H E S E C O N D W O N D E R

1024X768

Plus: VGA, EGA, CGA, MDA & Hercules on Standard MULTISYNC monitors

Yes! the Phenomenal VGAWONDER does it all at IBM Hardware level compatibility with automatic monitor detect and no dip switches or jumpers to set. A HOT CARD for the 286/386 POWER USER with AUTO BUS DETECT for 8 or 16 bit slots, running with a 16 bit datapath with 1:1 interleave. 100% IBM HARDWARE LEVEL COMPATIBILITY means that ALL software and operating systems designed for IBM systems will run. 1024 WILL BE DISPLAYED IN COLOR ON STANDARD MULTIFREQUENCY MONITORS. Although these features are expected from ATI they are NOT AVAILABLE from other manufacturers. EGA on all monitors including RGB & TTL means a perfect card for networks. MOUSE ON BOARD! ATI built the mouse right in to this one, why not? No extra charge! VGAWONDER is available in both 512K and 256K Versions. Ask your dealer for more information.

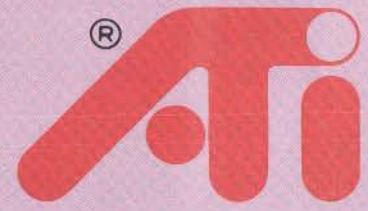

TECHNOLOGIES INC.

Technology you can Trust.

ATI Technologies Inc.
3761 Victoria Park Ave., Scarborough, Ontario
Canada M1W 3S2 Telex: 06-966640 (ATI TOR)
Tel: (416) 756-0718 Fax: (416) 756-0720



Circle 27 on Reader Service Card

ATI, VGA WONDER — ATI Technologies Inc.; Multisync — NEC Home Electronics Inc.;
AUTOCAD — Autodesk Inc.; WINDOWS — Microsoft Inc.; GEM — Digital Research Inc.;
VENTURA — Xerox Corp.; HERCULES — Hercules Computer Technology Inc.;
BM, VGA, EGA, CGA — International Business Machines Corp.



Aw...What the Heck!

EXTREMELY POWERFUL

DesignCAD 3-D version 2.0 is as powerful as most CAD systems costing \$5000-\$10,000! Features like: Complex Extrusions-linear, scalar, and circular, Blending of Surfaces, Shading, Cross Sectioning, Complex Sweeps and Translations, and Boolean operations make DesignCAD 3-D one of the most powerful 3-D CAD systems available... at any price! Engineers, Architects and Consultants constantly tell us that they use CAD systems costing thousands of dollars which are not as powerful as DesignCAD 3-D.

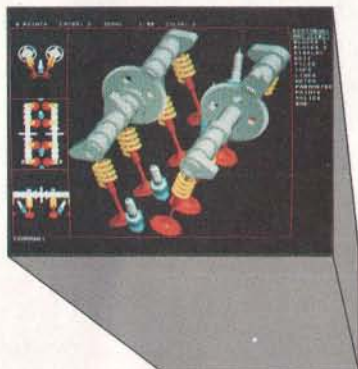

VERY EASY TO USE

Just because DesignCAD 3-D is powerful doesn't mean it is difficult to use. Single keystroke commands and side-bar menus which give short directions on how to proceed make DesignCAD 3-D a snap to use! While not required, DesignCAD 3-D supports all popular digitizers and mice.

Many of the older, more cumbersome CAD systems require weeks of training before a user can be productive. DesignCAD 3-D users find they can be producing useful drawings in a matter of minutes! In a recent CAD contest only one contestant was able to match our drawing time. The package sold for \$3000.00. The other CAD packages took up to twice as long to perform the same drawing and cost up to \$5000.00!

Still don't believe us? The goblet pictured below required only 16 keystrokes and 3 commands to create! The top, front, side, and isometric views were created simultaneously... in less than one minute!

VERY LOW PRICED

The first question asked by many people is, "Why is DesignCAD 3-D priced so low?" The answer? After developing DesignCAD 3-D version 2.0, we were unable to decide how the product should be priced. We consulted experts. We used the finest spreadsheets on the market. We took employee polls. Finally, in the great American Tradition, we said, "Aw... What the Heck! Let's see the other guys beat this price!" DesignCAD 3-D version 2.0 sells for \$399.



DesignCAD 3-D only \$399!

WHY BUY THIS ONE?

There is a very important reason to buy DesignCAD 3-D. **PERFORMANCE.** No other CAD system can match our price/performance ratio. Many people make the serious mistake of thinking that it is necessary to spend thousands of dollars to obtain "a good 3-D CAD system." This is not true! We talk to people everyday that are sadly disappointed with their "expensive" CAD systems. Don't be one of them! Call us and we will send you a complete set of literature and a free slide show demo disk. Once you compare DesignCAD 3-D version 2.0 with other CAD systems we know you will choose DesignCAD 3-D.

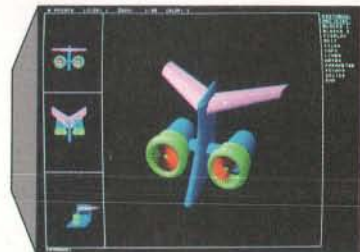

DON'T TAKE OUR WORD FOR IT

Here is what other people have to say about DesignCAD 3-D:

"After you've worked with DesignCAD, the single keystroke commands are simple to remember and it becomes easy to "flick one key" to execute a command. An extremely ergonomically designed program."

HENRY LEVET, Levett & Daigle Architects - New Orleans, LA
Designed a 65,000 sq. ft. nursing home using DesignCAD

"Recently I worked with a firm that builds decks. They purchased your product on my recommendation. I sat down with them and in two hours they were very proficient in DesignCAD. Now they are more effective; and we can communicate... it's wonderful to be able to do a block repeat 42 times and there are 42 2x4's to make the deck!"

J. TURNER, Architect, TAO Ltd. - The Woodlands, Texas

"Allows scientists and engineers to expend minimum time learning and using CAD software so that their time can be expended on the project at hand. It also allows scientists and engineers to quickly present to management all views of a subject. (3-D)."

DR. STEVENS, NASA Space Scientist/Engineer



HOW DO I GET ONE?

DesignCAD 3-D version 2.0 is available from most retail computer stores, or you may order directly from us. DesignCAD 3-D is available in a number of foreign languages from distributors throughout the world. All you need to run DesignCAD 3-D is an IBM PC Compatible and 640K RAM. DesignCAD 3-D supports most graphics cards, printers, plotters and digitizers. Free information and a demo diskette are available by contacting us at:

American
Small Business Computers, Inc.

327 South Mill Street
Pryor, OK 74361
918/825-4844
FAX: 01-918-825-6359
TELEX: 9102400302



JUST A FEW FAX

Can personal computer fax boards cut it in the real business world?

In the past year or so, the question "Can you fax it to me?" has become ubiquitous. The office fax machine, once a curiosity, has suddenly become a necessity. And now that nearly every office has one, nearly every office is *expected* to have one. If you don't, people think there's something wrong with you.

Of course, the standard tabletop fax with its built-in telephone is a familiar sight, but personal computer owners have an additional way to join in the fax landslide. A number of companies, including Quadram and Brooktrout Technologies, make fax cards for personal computers. These are cards that plug into the expansion bus on your IBM PC compatible or Mac II and allow the computer to communicate with another fax machine. Other cards include a built-in modem or fit into the expansion bus on a laptop computer.

These products have been around for several months. Clearly, they work. The question is, how well? More important, how well do they work in conjunction with a standard tabletop fax machine?

The Rest of the World

The ability to work with the world of tabletop fax machines is important for one simple reason: The vast majority of other fax units in the world are of that type. You want the documents sent by your business to look good, and you want the people at the other end to be able to send and receive just as they would with any other machine. This is one of the few areas in computing where you must plan on the ability to communicate routinely with non-users.

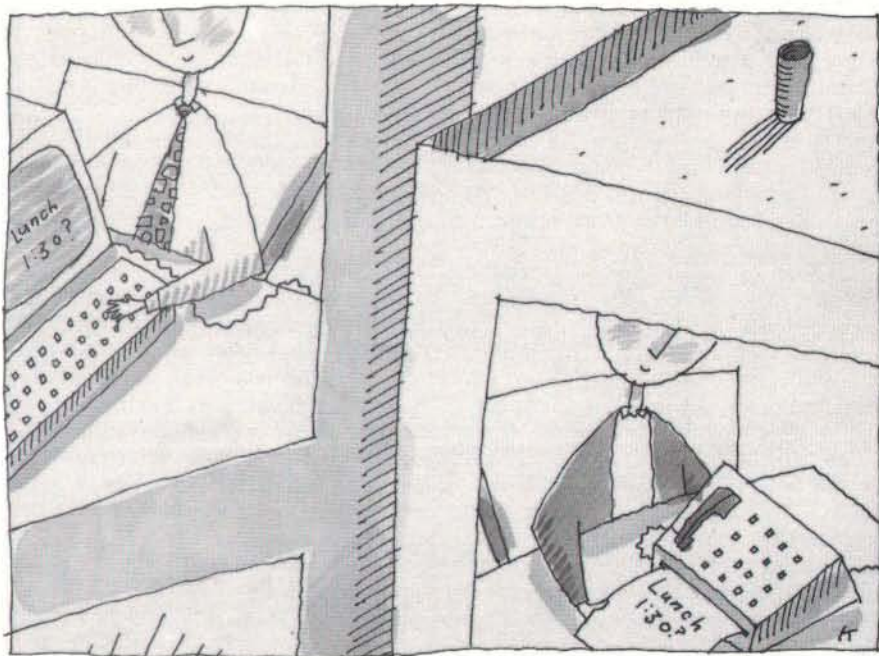

To find out how well these cards worked, I sent documents to and from them, using an inexpensive Murata M1200 fax machine. This is a full-featured, 9600-bps machine that sells in the Washington, DC, area at a discounted price of less than \$700. The Murata M1200 has a built-in scanner, a thermal printer, and a telephone handset. You can set it for either normal-resolution (200 by 98 dots per inch) or high-resolution (200 by 196 dpi) modes, and you can set it to answer the phone automatically or manually. The Murata can also respond to polling by other fax machines, and it will make copies for you.

The Cards

I looked at two popular fax cards, the Brooktrout Technology Fax-Mail 96 and the Quadram JT Fax 9600. Both are full-featured 9600-bps cards that work in an IBM PC- or AT-compatible computer. They include support software that lets you transfer ASCII files. They also have

methods of capturing printer output destined for Epson printers and converting that to a fax file. Both support a variety of printers, including the LaserJet II. Finally, both have the ability to convert PC Paintbrush graphics files to fax format.

Neither card is difficult to use. Installation normally consists of plugging the card into an empty slot in your computer, attaching the telephone cables, and installing the software. The Quadram JT Fax is addressed through a location in memory, while the Brooktrout card takes the place of a COM device, usually COM2. Quadram provides a variety of alternate memory address settings in the event that the card conflicts with existing hardware. With the Brooktrout Fax-Mail 96, you can change the COM port assignment. There's little else that you need to do to the hardware to install either of these boards.

The two machines are also much the

continued

same in use. A memory-resident program monitors incoming calls and has the fax card answer if you've turned on the automatic answering feature. This can happen without user intervention. Likewise, you can set a fax for transfer at a particular time, and that will take place in the background. You can send a fax manually at any time, of course.

The Brooktrout Fax-Mail 96

This is a full-size card that retails for \$599, or slightly less than the Murata. It uses the Rockwell fax modem chip set and is accompanied by software that includes a text editor and a graphics image editor. This graphics editor is especially useful, because it will let you edit a fax you've received from elsewhere. Brooktrout suggests this as a way to append your letterhead and signature to your faxes. Essentially, this means that you can use a standard fax machine as a scanner for the computer-based fax. If you don't want or need to buy an expensive scanner, this is a pretty handy way to do an occasional scan.

The Fax-Mail 96 lets you reduce images before printing them. This is important because fax machines normally add a couple of lines to the top of an image when they send it so that there is room for the ID information of the sending machine. When the fax is received and printed, it will frequently cause a half inch or so of the bottom of each page to be printed on the following page unless the image is slightly reduced. With the Fax-Mail 96, you can choose the amount of reduction you need.

The Fax-Mail 96 also lets you specify a reasonably wide variety of graphics adapters for your computer, although it does not support VGA graphics resolution. This is too bad, because the documents on the screen are not always legible when viewed in EGA mode. You can enlarge the screen image and read it that way, however.

When I used the Fax-Mail 96 to send a document to the tabletop Murata M1200 fax machine, it delivered a remarkably clear image. In fact, it causes the fax machine to produce text closely resembling laser-printed output. I tried sending faxes to the Murata from several other fax machines, including some expensive Xerox telecopiers. The images were never as clear as they were from the Fax-Mail 96.

Other people who have used the PC fax cards tell me that the output usually looks good on the receiving end. This is because the printer part of a fax machine generally has a higher resolution than the scanning part; if you're not scanning the

ITEMS DISCUSSED

Fax-Mail 96.....\$599
Brooktrout Technology, Inc.

110 Cedar St.
Wellesley Hills, MA 02181
(617) 235-3026

Inquiry 981.

JT Fax 9600.....\$795
Quadram

One Quad Way
Norcross, GA 30093
(404) 923-6666

Inquiry 982.

Murata M1200.....\$899.95
Murata Business Systems, Inc.

4801 Spring Valley Rd.
Dallas, TX 75244
(214) 403-3300

Inquiry 983.

input document, you get cleaner output. If you want to impress your correspondents with the quality of your output, the Fax-Mail 96 is a good way to do it.

One of the few weak points of the Brooktrout Technology Fax-Mail 96 is the lack of a speaker to monitor the progress of the call. A status screen on your computer shows the call's progress, but a speaker like the ones found on most fax machines would be nice.

Quadram JT Fax 9600

The JT Fax 9600 is a two-thirds-size board designed to fit into IBM PC and AT compatibles. It's more expensive than the Brooktrout Technology board, listing at \$795, but it also uses the Rockwell chip set. Slower versions of this board are considerably less expensive.

For most of its operations, the JT Fax 9600 is as easy to use as the Fax-Mail 96. Like the Fax-Mail, it supports the LaserJet II and will print received faxes on that printer and a variety of dot-matrix printers. Realistically, a dot-matrix printer would be terribly slow, however. Like the Fax-Mail 96, the JT Fax 9600 sends exceptionally clean text to a standard fax machine. The output looks almost as good as laser-printed output and much better than output received from standard fax machines.

In one area, I found the JT Fax 9600 preferable. It had a speaker, so I could hear the call go through. On the other hand, the software had no way to monitor the progress of the transmission, so I had no idea what the transfer speed was. As it turns out, I was able to monitor this with the Murata. Although the JT Fax sent

documents at 9600 bps with no trouble, it was not able to receive a fax from the Murata at a speed higher than 4800 bps. (It would receive from some other fax machines at 9600 bps.) This was not a problem with the Fax-Mail 96.

Are They Worth It?

If you already have a scanner and a laser printer, adding a fax card instead of buying a fax machine would be a logical move. It would gain you the capability of a fax machine at a slightly lower price. On the other hand, if you have to buy any of those parts, it's cheaper to get a standard fax machine like the Murata.

There are a couple of other settings where these devices make sense. If the quality of output is a significant factor, the ability of the fax cards to produce superior output, even in the remote fax machine, might indicate a requirement. If you need to use the machine on a LAN, then you will have to use a card, because fax machines don't attach to LANs. In addition, the fax cards can handle sophisticated calling lists and deliver faxes while unattended. Only the most expensive fax machines will do this.

Of the two fax boards considered here, the Brooktrout is both less expensive and more trouble-free. I had problems with the ability of the Quadram board to handle my VGA-equipped AT clone. The Fax-Mail 96 had no such problems; though it doesn't support VGA resolution, it worked fine with my VGA monitor, emulating EGA resolution.

This isn't a full-fledged review, but if I had to choose between the two fax boards considered here, I'd take the Brooktrout. I should add, though, that the first choice for me, and for many in small business, would probably be a standard fax machine like the Murata. It doesn't tie up the computer, and the quality of output isn't all that important for most of what I do. Fax cards remain specialized devices that can meet some needs very well, but for general-purpose, light-duty fax service, I question their value. ■

Wayne Rash Jr. is a consulting editor for BYTE and a member of the professional staff of American Management Systems, Inc. (Arlington, VA). He consults with the federal government on microcomputers and communications. You can contact him on BIX as "waynerash," or in the to.wayne conference.

Your questions and comments are welcome. Write to: Editor, BYTE, One Phoenix Mill Lane, Peterborough, NH 03458.

Compuclassics

ACCOLADE	
Test Drive	22.00
ADOBE	
Illustrator/Windows	409.00
ALDUS	
Pagemaker	499.00
ALPHA	
Alpha/Four	329.00
AMERICAN SMALL BUSINESS	
Design Cad	159.00
Design Cad 3D	209.00
APPLAUSE	
Perfect Addition	29.00
APPLICATION TECHNIQUES	
Pizzazz Plus	69.00
ASHTON-TATE	
DBase IV	509.00
Framework III	455.00
DBase III Plus	455.00
Mastergraphics	295.00
Multimate Advantage II	295.00
ASK SAM	
Ask Sam	179.00
AUTODESK	
Autosketch Enhanced	65.00
BANNER BLUE	
Org Plus	55.00
BLOC PUBLISHING	
Formtool	59.00
BLAISE	
Turbo C Tools	85.00
Turbo Power Tools Plus	85.00
BORLAND	
Turbo C	99.00
Turbo Pascal	99.00
Turbo C Pro	169.00
Turbo Pascal Pro	169.00
Quattro	165.00
Sidekick Plus	135.00
Turbo Assembler/Debugger	99.00
Paradox	439.00
BOURBAKI	
1 Dir Plus	50.00
BRIDGEWAY	
Fast Trax	35.00
BRODERBUND	
Print Shop	39.00
Memory Mate	45.00
BUMBLEBEE	
DB Fast/DOS	60.00
BUTTONWARE	
PC File DB	69.00
CALIFORNIA SCIENTIFIC	
Brainmaker	79.00
CENTRAL POINT	
PC Tools Deluxe	79.00
Copy II PC	25.00
CHANNELMARK	
Quick Schedule Plus	49.00
CHRONOS	
Who-What-When	119.00
CLARION	
Professional Developer	409.00
COMPUTER ASSOCIATES	
Supercalc 5	319.00
Superproject Expert	455.00
CONCENTRIC DATA	
R & R Report Writer	109.00
CORE	
Corefast	79.00
CROSSTALK	
Crosstalk Mark 4	129.00
Remote 2	99.00
DAC	
Lucid 3D	62.00
DAC Easy Bonus Pack	119.00
DAC Easy Accounting	59.00
DATAEASE	
Dataease 4.0	509.00
DATAFORM	
Procomm Plus	52.00
DELFINA	
Perform	155.00
DELTA TECHNOLOGY	
Direct Access	55.00
DIGITAL RESEARCH	
Gem Artline	289.00
Gem Draw Plus	179.00
DIGITALK	
Smalltalk V286	145.00
DYNAMIC MICROPROCESSOR	
PC Anywhere III	80.00
ELECTRONIC ARTS	
Mavis Beacon Teaches Typing	35.00
Deluxe Paint II	69.00
EPYX	
California Games	25.00
FIFTH GENERATION	
Fastback Plus	109.00
FORMWORX	
Formworx w/Fill & File	89.00
FOX	
Foxbase Plus	199.00

FUNK	
Sideways	42.00
Allways	89.00
GAZELLE	
QDOS II	39.00
GENERIC	
Generic CADD Level 3	169.00
GIBSON	
Spinrite	52.00
GOLDEN BOW	
V Cache	45.00
HAVENTREE	
Interactive Easy Flow	115.00
IBM	
DOS 4.01	125.00
Displaywrite IV	289.00
INDIVIDUAL	
101 Macros For WordPerfect	45.00
INSET	
Inset Plus	109.00
INSIGHT DEVELOPMENT	
Laser Control	85.00
Print-A-Plot	109.00
INTUIT	
Quicken	35.00
LASERGO	
Go Script	155.00
Go Script Plus	285.00
LEARNING COMPANY	
Reader Rabbit	25.00
LOTUS	
Agenda	289.00
Other Products	Call
MATHSOFT	
Mathcad	215.00
MECA	
Managing Your Money	125.00
MERIDIAN	
Carbon Copy Plus Special	129.00
MICROGRAFX	
Windows Graph Plus	329.00
Designer	449.00
MICROLOGIC	
Tomado	55.00
MICROLYTICS	
Gofer	45.00
MICROPRO	
Wordstar Professional 5.0	229.00
MICROPROSE	
F19 Stealth Fighter	39.00
MICRORIM	
RBase For DOS	499.00
MINDSCAPE	
Balance of Power	30.00
MULTISOFT	
Super PC Kwik	65.00
MICROSOFT	
Quickbasic	67.00
Quick C	67.00
Windows 286	67.00
Windows 386	129.00
Excel	239.00
Macro Assembler	99.00
C Compiler	299.00
Word	229.00
Flight Simulator	35.00
MICROTEK	
Softbytes 286	35.00
NANTUCKET	
Clipper	429.00
NEW ENGLAND	
Graph-In-The-Box	75.00
NOLO	
Willmaker	35.00
NORTH EDGE	
Timeslips III	115.00
NOVELL	
Advanced Net 2.15	1959.00
Other Products	Call
OWL	
Guide	169.00
PAPERBACK	
VP Planner Plus	129.00
PATTON & PATTON	
Flowcharting II Plus	139.00
PAUL MACE	
Mace Utilities	55.00
PEACHTREE	
Compte Acting W/Data Qury	235.00
PERSOFT	
Ize	265.00
Smarterm 240	209.00
PERSONICS	
Ultravision	79.00
See More 1-2-3	49.00
PETER NORTON	
Norton Utilities	59.00
Norton Commander	55.00
Norton Utilities Advanced	89.00
POLARIS	
Packrat	265.00
PRECISION SOFTWARE	
Superbase 4	499.00
PRIME SOLUTIONS	
Disk Technician Advanced	119.00
PROXIMITY TECHNOLOGY	
Choice Words	65.00

PUBTECH	
File Organizer	145.00
QUAID	
Copywrite	55.00
QUALITAS	
386 To The Max	60.00
QUARTERDECK	
Desqview	79.00
QEMM 386	37.00
REFERENCE	
Grammatik III	52.00
RIGHTSOFT	
Rightwriter	52.00
RIX	
Colorix VGA Paint	109.00
ROYKORE	
Opus One	275.00
SAMNA	
AMI	99.00
SANTA CRUZ OPERATIONS	
SCD Operating System 286	405.00
SCITOR	
Project Scheduler 4	429.00
SIERRA ON-LINE	
Leisure Suit Larry #2	32.00
Kings Quest IV	32.00
Space Quest III	39.00
SIMON & SCHUSTER	
Webster Prof Thesaurus	79.00
SOFTKLOONE	
Mirror III	55.00
SOFTLOGIC	
Disk Optimizer	45.00
SOFTWARE DIRECTIONS	
Print Q	89.00
SOFTWARE MASTERS	
Flash	49.00
SOFTWARE PUBLISHING	
Harvard Graphics	299.00
PFS 1st Publisher	79.00
PFS 1st Choice	99.00
PFS 1st Graphics	89.00
Professional Write	145.00
SOLUTION SYSTEMS	
Brief	169.00
SPECTRUM HOLOBYTE	
Tetris	24.00
Falcon-AT	32.00
STSC	
Statgraphics	589.00
STORAGE DIMENSIONS	
Speedstor	39.00
SUBLOGIC	
Jet	32.00
Scenery Disks	Call
SYMANTEC	
Q & A	229.00
Timeline	389.00
Grandview	189.00
SYMOSOFT	
Hotshot Graphics	149.00
SYSTEMS COMPATIBILITY	
Software Bridge	79.00
THREE D GRAPHICS	
Perspective Jr.	109.00
TIMWORKS	
Publish It!	125.00
TRAVELING SOFTWARE	
Laplink III	85.00
Viewlink	89.00
TURBO POWER	
Turbo BTree Filer	79.00
Turbo Professional	79.00
UNISON WORLD	
Printmaster Plus	32.00
VERSASOFT	
DB Man V	139.00
WHITE CRANE	
Brooklyn Bridge	75.00
WISEWARE	
Primetime	69.00
WOLFRAM RESEARCH	
Mathematica 386	599.00
WORDPERFECT	
Word Perfect	239.00
Word Perfect Library	69.00
Word Perfect Network	355.00

WORDTECH	
Quicksilver Diamond	349.00
DBXL Diamond	115.00
XEROX	
Ventura Publisher	519.00
Xerox Presents	319.00
XOR	
NFL Challenge	69.00
XTREE	
Xtree Pro	69.00
ZSOFT	
Publishers Paintbrush	149.00
HARDWARE	
ACER	
Computers	Call
AST RESEARCH	
5251/11 Enhanced	599.00
Six Pak Plus 64K	129.00
ATI	
VGA Wonder 256	335.00
BELKIN/DATASPEC	
Cables/Switchboxes	Call
CENTRAL POINT	
Copy II Option Deluxe	119.00
CURTIS	
Ruby Plus	69.00
ELGAR	
IPS 1100 Power Backup	979.00
EVEREX	
Internal 2400 Modem	155.00
Computers	Call
FIFTH GENERATION	
Logical Connection 512K	579.00
HAYES	
Smartmodem 2400	459.00
HEWLETT PACKARD	
Font Cartridges	Call
IBC	
AT Replacement Battery	19.50
INTEL	
Above Board Plus 512K	455.00
Coprocessors	Call
KENSINGTON	
Masterpiece Plus	109.00
KEYTRONIC	
KB101 Plus Keyboard	99.00
KYE	
Genius Mouse	59.00
LOGITECH	
Scanman PC	199.00
New Logimouse	89.00
MICROSOFT	
Bus or Serial Mouse w/Paint	109.00
MICRO SPEED	
Fast Trap Serial	95.00
MOUSE SYSTEMS	
Bus or Serial PC Mouse II	95.00
NEC HOME	
Multisync 3D	759.00
ORCHID	
Pro Designer VGA Plus	409.00
PANASONIC	
KXP 1124 Printer	369.00
PARADISE	
VGA Plus	295.00
POLAROID	
EGA Palette	2399.00
PLUS	
Handcard 40	709.00
PRACTICAL PERIPHERALS	
2400 External Modem	195.00
SEAGATE	
Hard Disks	Call
SUMMAGRAPHICS	
Summasketch Plus 12x12	419.00
SYSGEN	
Bridge File w/adaptor	289.00
TOSHIBA	
Printers	Call
TOUCHBASE	
Worldport 2400 Modem	265.00
Worldport 2496 Fax Modem	519.00
VIDEO 7	
Vram VGA 256K	509.00

We ship to
APO & FPO
PO
Boxes

**WE
WELCOME
CORPORATE
ACCOUNTS AND
INTERNATIONAL
ORDERS**

**FAX YOUR
ORDER!
(818)
347-
9977**

► IMMEDIATE SHIPMENT ON PURCHASE
ORDERS FROM GOVERNMENT AND STATE AGENCIES,
CITIES, COUNTIES, SCHOOL AND UNIVERSITIES.

► Prices subject to change without notice and while stocks
last. ► We Ship the latest versions. ► We accept Visa, Master
card, American Express. ► 2% Surcharge on American Express

► Please call (818) 347-9400 for an Authorization # for defective goods on
your return will not be accepted. ► Due to copyright laws we cannot take
back any software where the seal has been broken. ► \$5 minimum shipping
per item, less on bulk orders. ► \$9 Blue Label shipping, \$3.50 C.O.D charge

► Heavier items are charged accordingly. ► We do not guarantee compatibility
► Call for prices for any software item not included in this ad. ► Order desk open 7 a.m
to 5 p.m. (PST), Saturday 10 a.m. - 2 p.m. (PST). ► P.O. Box 10598, Canoga Park, CA 91309
Showroom: 7959 Deering Ave., Canoga Park, CA 91304 ► Customer Service 818 347 9400
General Office 347 7500

ORDERS CALL 800 733 3888



A MACINTOSH WHO'S WHO

A chart that details the features of each member of the Macintosh family

Editor's note: This month we've kept Don Crabb quite busy with reviews and a special column for the Macintosh Special Edition in this issue. To give him a break in the action, we've decided to use his column to supply general information about Apple's growing line of Macintosh computers. Don't be alarmed; Don will be back next month.

Like the variety of colors Henry Ford offered with his Model T ("You can have any color you want, as long as it's black"), in 1984 Apple gave you a range of hardware options for the Macintosh computer: You had a choice of 128K bytes of RAM in a sealed case, a 400K-byte floppy disk drive, and nothing else.

How times have changed. With six different Macintosh computers now on the market, a new buyer has to sort through a

bewildering array of CPUs and hardware combinations. Here's our scorecard to help out: Table 1 summarizes the features of each machine and should help you determine which Mac is best for you.

Note that the machines fall into two groups. First, there's the "compact" family whose trademarks are a small footprint and a built-in monitor. Expansion capabilities are limited to a single slot for both the Mac SE and the SE/30.

Then there's the "modular" family. Although these machines take up more of your desktop, they compensate by providing more slots. These NuBus slots let you plug in peripheral or coprocessor boards that expand the capabilities of the machine in any direction you see fit.

However, be careful when you expand your system: There are some minor differences that can turn into major problems if you're not aware of them.

Table 1: A comparison of the system features for Macintosh computers.

Machine	CPU	FPU	Clock speed	ROMs and mounting	Maximum RAM	Memory management hardware
Mac Plus	68000	None	7.83 MHz	128K-byte socketed DIP	2.5 to 4 megabytes ¹	None
Mac SE	68000	None	7.83 MHz	256K-byte socketed DIP	4 megabytes	None
Mac SE/30	68030	68882	15.68 MHz	256K-byte SIMM-mounted	8 megabytes	Part of CPU
Mac II	68020	68881	15.68 MHz	256K-byte socketed DIP	8 megabytes	Optional 68851 PMMU
Mac IIx	68030	68882	15.68 MHz	256K-byte SIMM-mounted	8 megabytes	Part of CPU
Mac IIcx	68030	68882	15.68 MHz	256K-byte soldered DIP ²	8 megabytes	Part of CPU

¹ RAM expansion is determined by the limits of the Mac Plus power supply. Beige-colored Macs should be expanded to only 2.5 megabytes; platinum-colored Macs can be safely expanded to 4 megabytes.

² A SIMM socket is available for future ROMs. A jumper must be removed for the CPU to address the SIMM socket.

First, the Mac SE/30 can't use SE expansion boards, because the slot connector and form factor are different.

Second, when you expand the memory on these systems, check the access time of the RAM single in-line memory modules you buy. The Mac Plus and SE use 150-nanosecond SIMMs, while the rest use 120-ns SIMMs.

Finally, old-timers who own the original Hard Disk 20—the one with the external floppy disk drive connector—should consider selling it or obtaining a SCSI port for it; the Mac SE/30 and IIcx don't support this type of drive. ■

Tom Thompson is a BYTE senior technical editor at large. He has a BSEE from Memphis State University. He has used Macs for many years and has coauthored many of the First Impressions of Macs. He can be reached on BIX as "tom_thompson."

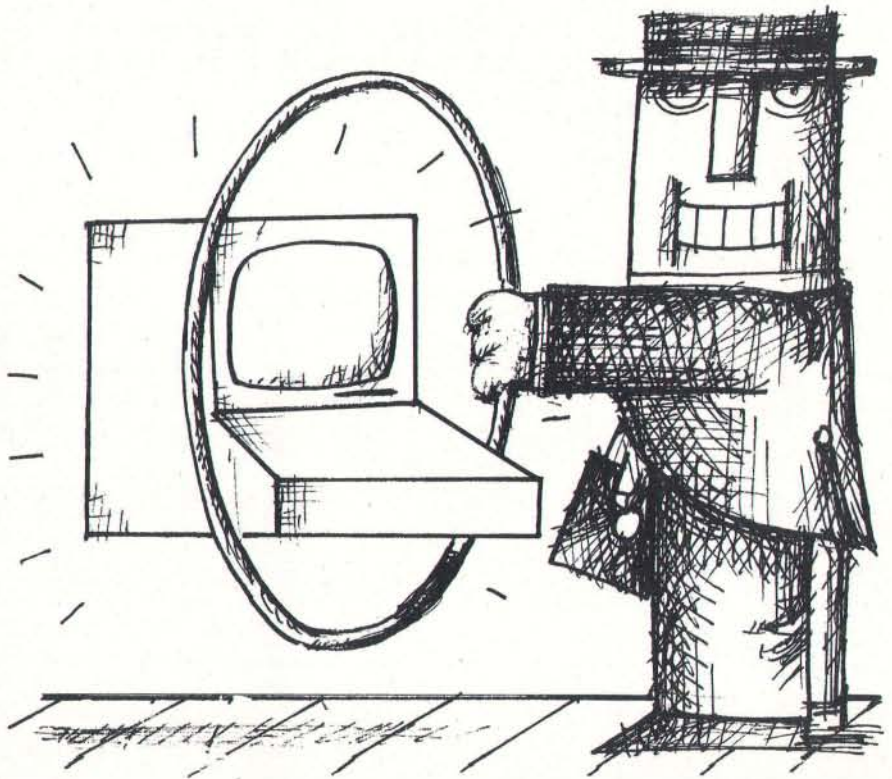

Slots	Floppy disk drive	External storage	Keyboard/mouse	Supports Color QuickDraw?	Sound
None	400K/800K	SCSI, floppy	Mac Plus keyboard, Mac mouse	No	Monophonic using software drivers
1—SE bus	400K/800K	SCSI, floppy	ADB Standard or Extended keyboard, ADB mouse	No	Monophonic using software drivers
1—030 Direct Slot	FDHD ³	SCSI, floppy	ADB Standard or Extended keyboard, ADB mouse	Yes	Stereophonic using custom chip
6—NuBus	FDHD ³	SCSI	ADB Standard or Extended keyboard, ADB mouse	Yes	Stereophonic using custom chip
6—NuBus	FDHD ³	SCSI	ADB Standard or Extended keyboard, ADB mouse	Yes	Stereophonic using custom chip
3—NuBus	FDHD ³	SCSI, floppy	ADB Standard or Extended keyboard, ADB mouse	Yes	Stereophonic using custom chip

³ The FDHD (floppy disk high-density) drive can handle a variety of machine formats: 400K-byte, 800K-byte, and 1.44-megabyte Mac; 720K-byte and 1.44-megabyte DOS or OS/2; and 800K-byte Apple II ProDOS.

We keep telling people
this is not a laser printer.



The new \$995 HP DeskJet PLUS Printer.

But they keep looking at the evidence.



Mr. Arnold R. Jones
220 Bush Street, Suite 845
San Francisco, CA 94104

Dear Reader:

Imagine being able to put out merged text and graphics that look like a photograph. In fact, that your clients will think you're using a laser printer. You're not. You're using the \$995 HP DeskJet PLUS printer instead.

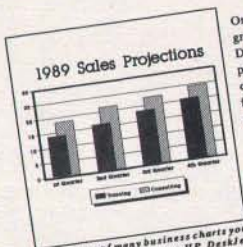

This is one of many business charts you can print out on the new HP DeskJet PLUS printer. Software for this test and graphics demonstration by Harvard Graphics.

One reason you can graph around so popular software create your message favorite program and beautifully.

We call it a price small price, for

Of course, we how good it trip to your for yourself.

Sincerely,

Alan Grube

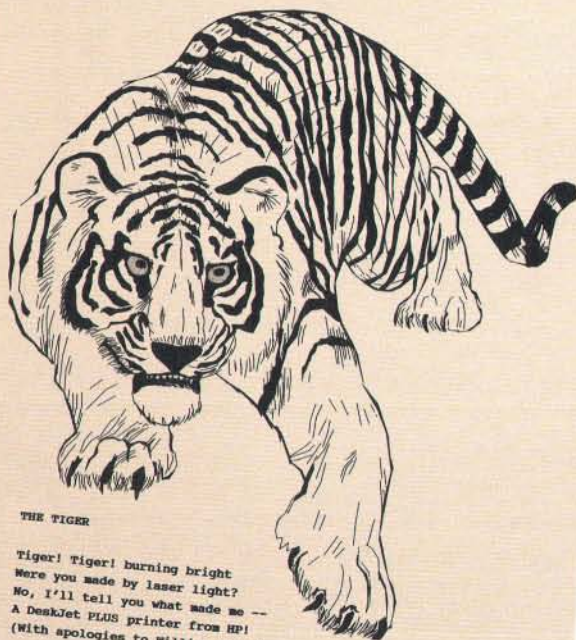

THE TIGER

Tiger! Tiger! burning bright
Were you made by laser light?
No, I'll tell you what made me --
A DeskJet PLUS printer from HP!
(With apologies to William Blake)

MegaCorp 1988 Sales History

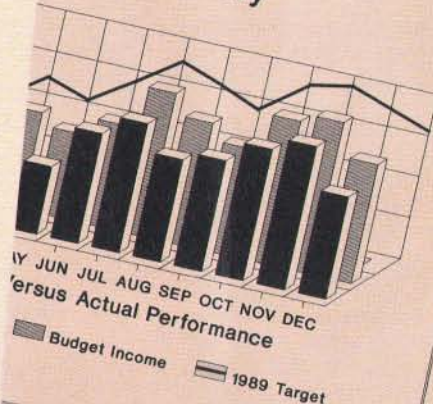

You won't believe your eyes (or ears), either. The HP DeskJet PLUS printer gives you the same crisp, black lettering. Clean, sharp graphics. And whisper-quiet operation. But it uses advanced inkjet technology to supply these laser-like qualities for the price of a 24-wire printer.

For just \$995, you get 300 dpi in a trim 15-pound package that's twice as fast as the original. What's more, it has built-in landscape and improved font selection. Including ten built-in fonts and over 100 optional fonts, with sizes up to 30 points. And its 20,000-hour MTBF

assures a long, happy life.

So call 1-800-752-0900, Ext. 276J for the name of your nearest authorized HP dealer. Then judge the HP DeskJet PLUS printer for yourself.



Discover Parallel Processing!



Monoputer/2™

*The World's Most Popular
Transputer Development System*

Since 1986, the MicroWay **Monoputer** has become the favorite transputer development system, with thousands in use worldwide. Monoputer/2 extends the original design from 2 to 16 megabytes and adds an enhanced DMA powered interface. The board can be used to develop code for transputer networks or can be linked with other Monoputers or Quadputers to build a transputer network. It can be powered by the 20 MHz T414 or T800 or the new 25 MHz T425 or T800.

Parallel Languages

Fortran and C Make Porting a Snap!

MicroWay stocks parallel languages from 3L, Logical Systems and Inmos. These include one Fortran, two Cs, Occam, Pascal, and our own Prolog. We also stock the NAG libraries for the T800 and Rockfield's structural and thermal finite element package. A single T800 node costs \$2,000, yet has the power of a \$10,000 386/1167 system. Isn't it time you considered porting your Fortran or C application to the transputer?

Quadputer™

*Mainframe Power
For Your PC!*

MicroWay's **Quadputer** is the most versatile multiple transputer board on the market today. Each processor can have 1, 4 or 8 megabytes of local memory. In addition, two or more Quadputers can be linked together with ribbon cables to build large systems. One MicroWay customer reduced an 8 hour mainframe analysis to 15 minutes with five Quadputers, giving him realtime control of his business.

For further information, please call MicroWay's Technical Support staff at (508) 746-7341.

Micro Way

Circle 182 on Reader Service Card

World Leader in PC Numerics

P.O. Box 79, Kingston, MA 02364 USA (508) 746-7341
32 High St., Kingston-Upon-Thames, U.K., 01-541-5466
USA FAX 617-934-2414 Australia 02-439-8400 Germany 069-75-1428



OS/2 DISK GEOGRAPHY

After you install OS/2, it's time to go exploring on your hard disk

Let's continue with the discussion of setting up OS/2. Now that you've loaded those megabytes and megabytes of data on your hard disk, just what is on there? The OS/2 installation created six subdirectories and deposited a few files in the root directory as well.

The Root Directory

The root directory contains CONFIG.SYS—the OS/2 version—and may include a batch file named STARTUP.COM, a file that serves a function similar to AUTOEXEC.BAT for DOS. This directory also has some files with the extension .SYS: CLOCK01.SYS, DISK01.SYS, KBD01.SYS, PRINT01.SYS, and SCREEN01.SYS. These files are the device drivers that replace the BIOS under OS/2, which needs them because it can't use the real-mode ROM BIOS routines. It can use only protected-mode routines. Also, the ROM BIOS routines are not reentrant—they can be used only in a single-threaded operating system.

In fact, OS/2 uses the IBM PC's BIOS very little. The main use that OS/2 has for the BIOS is in the initialization routine—the code that gets executed when the machine is first powered up. To switch from OS/2 back to the DOS mode, OS/2 must trick the processor by resetting it. Upon reset, the processor executes the initialization routine. A poorly written initialization routine renders a machine incapable of running OS/2. Fortunately, it can be fixed with a simple upgrade of the BIOS.

The .SYS files are the avenue whereby a manufacturer can tailor OS/2 to its ma-

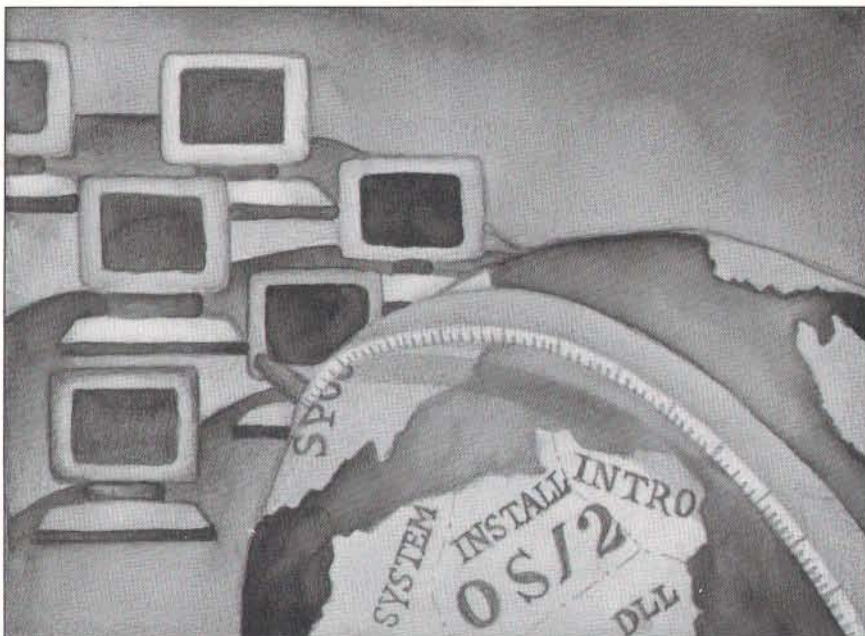

chine. These files are the main reason that IBM OS/2 does not run on some clones. It is possible to write a fairly generic set of .SYS files. In fact, Microsoft shipped such a set with the Software Development Kit. But manufacturers might want a machine-specific set of device drivers, either to reduce competition or to allow OS/2 to better exploit the special features of that manufacturer's machine.

This means that theoretically you can run IBM OS/2 on a Tandy machine by putting the device drivers from Tandy OS/2 on the IBM OS/2 disk.

The final item in the root directory is a version of COMMAND.COM used by the DOS mode session (the new IBM term for the compatibility box).

Subdirectories

The \OS2 subdirectory contains several subdirectories of its own—INSTALL, INTRO, SYSTEM, and DLL—as well as a number of program files.

This subdirectory contains the usual

DOS-like programs (e.g., CHKDSK, COMP, and FORMAT). There's even that old favorite, MORTGAGE.BAS. There are also some new programs. Some of the more interesting ones are

- MOUSEAx.SYS: mouse drivers
- PMCPL.EXE: the control panel
- E.DEF, E.EXE, and E.MSG: the IBM System Editor (SE)
- OS2.INI: a data file that stores your preferences about screen colors, menus, and so forth. Unlike Window's WIN.INI, it is not ASCII, but some binary format.

IBM included an SE to take the place of EDLIN, something new to OS/2 1.1. It isn't bad, being miles better than EDLIN. It's not quite as good as the IBM Personal Editor, but then, the PE doesn't run under OS/2. Sadly, IBM hasn't announced if the PE is coming out for OS/2. I know I sound a mite crotchety

continued

AMSTRAD**PORTABLE IBM PC-XT
COMPATIBLE LAPTOP
LIQUIDATION****FACTORY NEW! FACTORY PERFECT!**

It's small and convenient to handle. But don't let the size fool you. It's a full-featured PC-XT package to keep you on the move.

- 8086 16-bit processor, 8MHz. clock.
- 512K RAM. • Two 720K 3-1/2" disk drives.
- 100% IBM compatible.
- Integrated display adapter fully compatible with MDA & CGA. Drives either the LCD panel or an external monitor.
- 640 x 200 pixel supertwist LCD panel supports all CGA & MDA graphics and text modes. • Five XT expansion slots.
- Includes serial & parallel Centronics ports.
- Enhanced AT-type keyboard w/101 keys.
- Compartment for 10 alkaline "C" cells to give up to eight hours of use.
- Microsoft MS-DOS 3.3 operating system.
- Battery-backed real time clock with scratchpad RAM. • AC adapter.
- Full user manual.
- Carrying case with pockets for manual and disks. • Weight: 11 lbs. excluding batteries.
- Carrying size closed: 17-3/4"Lx9"Dx4"H.
- Color: Tan.
- Model #: PPC512DD.
- 90 Day Warranty!

PUBLIC NOTICE

Due to a manufacturer's closeout, we've received a large inventory of these AMSTRAD Computers. As a result, we can now offer them to you at **GREAT SAVINGS!**

Manufacturer's
Suggested Retail
\$1,049.00

DAMARK PRICE:**\$599**

Item No. B-1279-120535
Insured Ship/Hand.: \$10.00

**FOR FASTEST SERVICE
CALL TOLL FREE**

1-800-950-9090**DAMARK INTERNATIONAL, INC.**

6707 Shingle Creek Parkway, Minneapolis, MN 55430
Customer Service • 1-612-566-4940

Please send me:

_____ **AMSTRAD Laptop Computer** @ \$599
each, plus \$10.00 s/h each.
MN res. add 6% sales tax.

Name _____

Address _____

City, State, Zip _____

 Check/MO VISA Master Card Discover

Card No. _____

Exp. Date _____

Ph. # () _____

Item No. B-1279-120535

DELIVERY TO 48 U.S. STATES ONLY

D

*ynamic
link libraries improve
OS/2 over DOS in
several ways.*

here, but I have yet to find an OS/2 editor as good as the PE. (And where's that legendary Big Blue user support for us PE partisans under OS/2, IBM?) Text editor preferences are religious issues. Ask anyone what text editor is good, and you'll get not only *an* answer, you'll get *the* answer.

The IBM SE has programmable keys and a fair number of primitive functions. I don't think anyone will leave BRIEF or Vedit in favor of the SE, but you won't draw derisive snickers as you would if you called yourself an EDLIN fan.

The \OS2\INSTALL subdirectory contains the programs that OS/2 used to install itself. You may want to erase these, as they're not used on a day-to-day basis. However, IBM recommends that you use one of these programs—DD-INSTALL.EXE—to install new device support disks, like the one that supports the CGA, which was just released. (The CGA drivers are pretty much what you would expect. Presentation Manager under CGA is usable, but you won't like it. It *does* mean that you can get started in PM work for a few less bucks, at least until you can afford EGA—or have to buy stronger glasses.)

At any rate, you may want to pull the programs in the \OS2\INSTALL subdirectory off the hard disk to a floppy disk before zapping them.

\OS2\INTRO includes an automated tutorial introducing you to basic PM operations. If you haven't worked with Windows before, it's worthwhile to work through the tutorial. When you're done, erase it from your hard disk.

The \OS2\SYSTEM subdirectory includes a potpourri of system-support routines and files. The error-trap routine (HARDERR.EXE) and the virtual memory manager (SWAPPER.EXE) are there, as is COUNTRY.SYS, which contains some of the international support. Putting COUNTRY.SYS in this subdirectory doesn't make a lot of sense.

The files that support international keyboards, character sets, currency symbols, date formats, and so forth are

- COUNTRY.SYS: date and time formats, currency symbols, and a collation sequence
- KEYBOARD.DCP: international support for alternate keyboard maps
- VIOTBL.DCP: support for alternate character sets on-screen
- 5202.DCP and 4201.DCP: support for alternate character sets on IBM printers
- KEYB.COM: switches keyboard maps in midsession

For some reason, IBM put all the files but the last in \OS2. I don't know why. By the way, an unsung benefit of OS/2 is the simplification of the international support. I used to dread trips to London to do software seminars because every time I did, I had to relearn a pile of commands to support the British keyboard. Under OS/2, there are only five international commands, and they are consistent in syntax and simple to learn.

Dynamic Link Libraries

Last is the \OS2\DLL subdirectory, which contains the dynamic link libraries. DLLs improve OS/2 over DOS in several ways. To understand how, let's first back up and review how DOS supports communication between applications like Lotus 1-2-3 and the outside world. An application has to print hard copy on the printer, talk to the screen, and read the keyboard, to name just the basics. A well-behaved program doesn't directly access the keyboard, screen, or printer port—it *asks* DOS to do so.

Moreover, a program doesn't merely jump into the middle of DOS—it calls DOS through a well-documented *entry point*, most commonly something called INT 21. Entry points are nowadays called Application Program Interfaces. DOS's API, INT 21, can do any of a large number of things. Exactly *what* you want it to do is specified by a number in a CPU register called the AX register, or its component registers, AL and AH. Here are a few examples of DOS INT 21 functions (description and AH value): read a character from the keyboard (01), write a character to the screen (02), or print a character (05).

So, for example, to put an *A*, whose ASCII code is 41 hexadecimal, on the screen, you would use the following piece of assembly language code:

```
MOV DL,41H
MOV AH,2
INT 21H
```

continued



3 Heads Are Better Than 2

**The Standard Just Raised Its Standard!
LapLink III Now Includes Serial and
Parallel Transfer Capability in One Package!**

Introducing LapLink III.

LapLink III is the only file transfer package that's all-inclusive, featuring a unique universal cable that offers both serial and parallel transfer options in one complete unit. This super-powered LapLink is also the fastest transfer product on the market - up to 200,000 baud or higher serial transfer and up to 500,000 baud or higher with parallel transfer. This means you could transfer a 20 meg hard drive in just six minutes! Not only is it fast, but all data is transferred with 100% accuracy through LapLink's error checking system.

What if you've lost or misplaced your disks? No sweat. LapLink III has taken care of this common problem by offering Remote Installation capability. You can automatically send the LapLink program to the remote computer and then transfer your files. For those files that you transfer on a regular basis, you can easily set up automatic batch transfers. What could be simpler.

LapLink III is convenient, fast and easy to use. It transfers files between IBM and compatibles, laptop and desktop, including the IBM PS/2, with just a few keystrokes. It installs in seconds and features a split-screen design for showing files in both computers.

LAPLINK

Release III



LapLink III comes complete with the universal cable, 3 1/2" and 5 1/4" diskettes and easy-to-read documentation. It's surprisingly affordable at **\$139.95**.

No need to put *your* heads together—we've done it for you! To purchase LapLink III, contact your local computer store today. Or, for more information, call Traveling Software at **800-343-8080** or inside Washington state at **206-483-8088**.

Traveling Software



18702 North Creek Parkway
Bothell, WA 98011

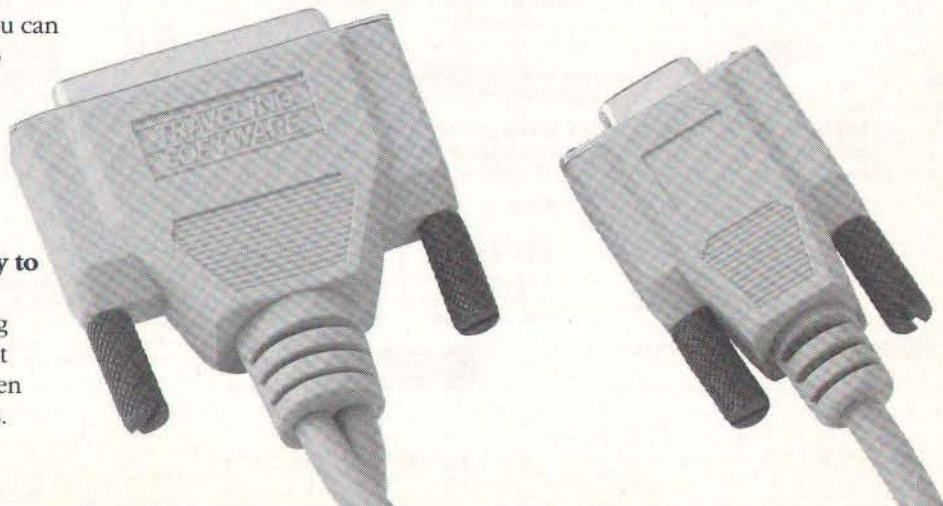

The first line puts a 41 hexadecimal in the DL register. The DL register must contain the ASCII code of the character that you want to put on the screen. (How did I know? I looked it up in the *DOS Technical Reference*.) The AH load tells DOS which function to perform, and the INT 21 then calls DOS. On return, many (but not all) INT 21 calls put a *return code* in the AL register to show whether the requested operation succeeded or failed.

This is all simple enough, but it does require the use of assembly language, and that scares an awful lot of people. Also, it's not too descriptive—you've got to look up what "AH=2" implies in a reference manual. Moreover, since you're using AH, an 8-bit register, to identify a function call, you're restricted to 256 function calls. Finally (and this isn't obvious from the example), the DOS code is, like the BIOS code mentioned before, not reentrant. You can't call a DOS function from inside a DOS function. This has led to the most common error for authors of TSR programs—when you write a TSR program, you *dare not* call a DOS function!

OS/2 improves upon this with a different scheme—the DLL. A DLL contains OS/2 APIs. They're similar in nature to the INT 21 interface for DOS, but easier to work with. For one thing, you needn't write assembly language to use the DLLs—they're easily called from C, BASIC, or FORTRAN. The next attractive feature of DLLs is that they use symbolic names, as shown in the following example:

```
...
char msg[]="A"
...
VioWrTtTY(msg,1,0);
...
```

The 1 is the length of the message, and the 0 is the mandatory *handle* of the video I/O subsystem.

DLLs are, of course, reentrant. And because they have symbolic names, there's no restriction on the number of entry points. Microsoft claims that there are nearly a thousand for OS/2, although I haven't counted. Finally, they are dynamic—they load on demand. In other words, the operating system doesn't load

every possible piece of code, whether you need it or not—the DLLs load only when a program needs them.

Many DLLs came with the OS/2 kernel, under OS/2 1.0. Version 1.1 brought more DLLs to support the new APIs for the PM. IBM's Extended Edition offers even more. You can even write your own DLLs. For example, you might design a system of programs with much common code and put the common code in a DLL to save space.

Once you remove the Installation Aid and the Introduction tutorial, you'll find that OS/2 has taken a total of about 7.5 megabytes on your hard disk. Now you have some idea of just what all those files are. Next month, I'll show you how to customize your CONFIG.SYS file. ■

Mark Minasi is a managing partner at Moulton, Minasi & Company, a Columbia, Maryland, firm specializing in technical seminars. He can be reached on BIX as "mjminasi."

Your questions and comments are welcome. Write to: Editor, BYTE, One Phoenix Mill Lane, Peterborough, NH 03458.

OS/2 ^{and} ~~or~~ DOS? MultiBoot is the answer.

From BYTEWEEK/Feb. 6, 1989

"... Bolt Systems has come out with a program that does away with the dual-boot problem. And at \$49, MultiBoot will be an essential utility for any OS/2 user ...

MultiBoot is simple, foolproof, and it works flawlessly. It's an example of a much-needed utility that fills a niche, a niche that will widen as more users take up OS/2. We recommend it."

Not all DOS programs work in the OS/2 compatibility box. MultiBoot lets you install both systems in your computer. MultiBoot works with DOS versions 3.0-4.01 up. And OS/2 versions 1.0 and 1.1.

TO ORDER:

Send \$49.95* + \$3.00 shipping and handling (check or money order) to:

MultiBoot, Bolt Systems, Inc.
4340 East-West Highway
Bethesda, Maryland 20814

*Maryland residents add 5% sales tax.

or call 1-301-656-7133.
FAX: 1-301-907-8736, and order by Visa/Mastercard. Specify 3.5" or 5.25" diskettes.
Ask about our volume discounts

BOLT
A Product of Bolt Systems, Inc.

AFFORDABLE Large Format Plotting from \$1695

A-E
\$2695
(Sugg. ret. \$2995)

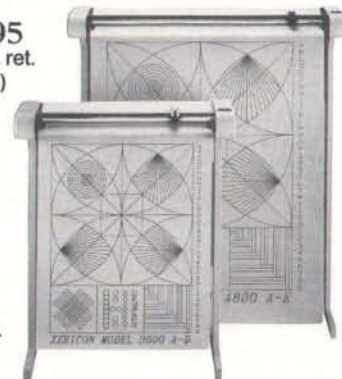

C-D
\$1695
(Sugg. ret. \$2295)

Made in USA

ECONOMICAL: \$1000 less than other large format plotters without sacrificing quality.

MULTIPLE MEDIA SIZES: As small as 8 1/4 x 11 or as large as 36 x 48. Eliminates the need for a second plotter.

REPEATABILITY AND RESOLUTION: .002 assures quality suitable for the most demanding applications including PCB artwork.

SPEED: 10" per second assures excellent drawing throughput.

VACUUM PAPER HOLD DOWN: Guarantees perfect registration every time.

CALL FOR FREE SAMPLE PLOT
(415) 490-8380

International Distributors Invited

ZERICON

40491 Encyclopedia Circle, Fremont, CA 94538

DM/PL is a registered trademark of Houston Instrument

Look great without a lot of makeup.

Transforming a blank piece of paper into a document that's as appealing as this calls for plenty of page makeup.

But if you're like the rest of the world, you've barely got enough time to write, let alone struggle with formatting.

Well, now you don't have to. Because Ami is here. And it's about time.

Ami can save you about three quarters of the time you're currently spending on everything from simple letters and memos to presentations, reports and newsletters.

How?



By letting you write your words and make up your pages *at the same time*.

In fact, you don't have to do any makeup at all.

Because Ami gives you over two dozen pre-designed style sheets that let you instantaneously transform



An Approach to Improved Business Communications with Ami Word Processing

Background - These incredible machines are called "personal" computers and talking to a new link - the look of a graph. The computer's interface determines how you tell the computer what to do. The



enter the interface, the more increase in people's productivity with computers.

For evidence, experts in applications at Samna Corporation's Ami word processor. Billed as the "word processor that lets you see what's on your mind," Ami represents the shape of future word processing products.

Much of Ami's productivity increases are attributed to its intuitive, WYSIWYG interface. Simply stated, Ami is the first, easiest way to get ideas on your screen and onto paper as beautiful, professional

looking documents. For the first time, you can process your words and your style

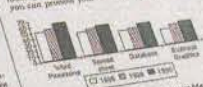

Figure 1-1. Projected Corporate Software Market.

layouts simultaneously, at one intuitive touch of a mouse... you've always wanted Ami is what you've always wanted to work presented in the. Extremely easy to learn and use... amazingly flexible and powerful. A genuine pleasure to enter

Ami only looks like a desktop word processor. It's actually a serious word processor that makes the work of the Microsoft® Word all the features and functions you require - including keyboard, alpha, or mouse control - plus a whole new dimension in creating productivity and

Ami's frames give you total flexibility. Turn them anywhere you like. Flip them up or down. And wrap text around them - automatically. Plus, you can use frames to integrate graphics with your text.

professional-looking write and design all at once - naturally the way it is supposed to be.

plain words into gorgeous documents.

Ami looks a lot like a desktop publisher. And the documents you can create with it have desktop publishing written all over them.

But as you'll quickly discover, Ami is a serious word processor that makes the most of Microsoft® Windows.

(If you don't have Windows, don't

worry. A runtime version is included.)

You can integrate text and graphics. Import both from other programs. And admire your documents from four fully editable page views.

Right now, we suggest you admire the \$199 price tag and

"A fast personal word processor... that makes it easier to produce great-looking reports, letters and memos than any other PC word processor."

PC/Computing

"Surprisingly sophisticated... quite simple to learn and use... among the most powerful of the executive word processors."

Michael J. Miller, in InfoWorld

"Makes desktop publishing class output a snap for the average user."

William Zachmann, in PC Week

send in this coupon right away.

Or just pick up the phone and call us at 1-800-831-9679.

Then you can take advantage of our 30-day money back guarantee.

Now that should help you make up your mind.

SAMNA

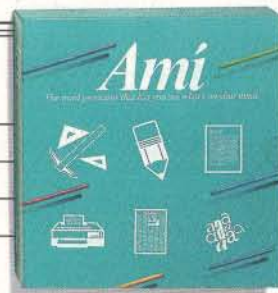

Make me look great for \$199.

Please rush me Ami!

Name _____

Address _____

City/State/Zip _____

Disk size: 5 1/4" 1.2MB 3 1/2" 720K

Phone _____

Check enclosed AMEX Visa MasterCard

Card No. _____ Exp. _____

Send coupon to: SAMNA, 5600 Glenridge Drive, Atlanta, GA 30342

Add \$10 for shipping & handling (GA residents add sales tax). Prices valid in U.S. only.

CALL 1-800-831-9679 FOR YOUR NEAREST DEALER.

BYTE

Requires IBM® AT, PS/2 or compatible (80286 or 386 CPU); CGA, EGA, VGA, or Hercules compatible displays; MS/DOS 3.0 or higher.

Ami is a trademark of Samna Corporation. All other trademarks and copyrights are acknowledged.

Circle 249 on Reader Service Card

ZORTECH

T · E · C · H · N · O · L · O · G · Y

C DEBUGGER \$89.95

Zortech's Debugger is the most sophisticated source level debugger now available. Because it is fully compatible with Codeview you can use it to debug Zortech or Microsoft programs.

Single step through source in one window while watching the variables (inc. automatics) change value in another window. You can even alter variables dynamically while the program executes.

Much better than Codeview, and full of advanced features like dual monitor, EMS memory and Mouse support. Call for data sheet.

C VIDEO \$299.95

Learn C Now! When you buy our C Course the first lesson you learn is in economics. You will save yourself or your company hundreds of dollars in seminar tuition fees.

You get ten one hour tapes containing 36 lessons ranging from the beginners introduction through to more advanced features.

Great for learning C! Any compiler and any operating system. Complete with 365 page workbook (additional copies available at \$29.95) and free Zortech C compiler - Call for data sheet.



HELP!

TECHNICAL HOTLINES

All our products are covered by an extensive FREE technical support hotline which is open five days a week from 9.00 till 5.00 (EST)

USA HOTLINE

617-646-6703
Fax: 617-648-9340

OUTSIDE USA

44-423-501552 (England)
Fax: 44-423-530746 (England)

C COMPILER \$89.95

The most advanced C compiler money can buy. No junk - just pure performance. Magazines are too embarrassed to print our optimized benchmark results - they don't want to upset the big guys!



The 600 page manual comes with a great introductory section and lots of solid technical data and examples. Fully compatible with Codeview and the new Zortech C Debugger. You get over 400 functions and the Flash Graphics package with drivers for Hercules, CGA, EGA and VGA - the fastest graphics library available! Context Sensitive Help, an advanced editor/environment, make, touch, five memory models, linker & librarian. Library Source only \$89.95 - Call for data sheet.

BOTH FOR \$149.95

ZC/TC/MSC TOOLKITS from \$49.95

Please state which compiler you have.

COMMS - \$99.95

Full Communications library with support for up to 8 ports, Xmodem, Kermit, ANSI, VT52, VT100, up to 38,400 baud, etc. 120 page manual.

BTREE - \$79.95

A database function library for C, complete with example program and over 50 functions. Easy to use with 92 page manual.

WINDOWS - \$69.95

Enhance your application with easy to use multiple text windows. Full demo program including 90 page manual.

PROSCREEN - \$69.95

Generates C source code for your application from screens that you draw. Too many features to list.

NEW! C++ VIDEO AVAILABLE NOW!

Please request full data sheets.

C++ COMPILER \$149.95

This is the world's only true C++ compiler for MS-DOS machines - there is no choice. Not to be confused with 'translators' which are slow, expensive, inefficient and not real C++ compilers.

More people use Zortech's C++ than any other C++ on any operating system. Zortech strives to ensure full compatibility with AT&T C++.

Zortech C++ contains all the features of Zortech C including the C compiler itself at no extra cost. Everything is in one neat package. Compatible with Codeview and the new Zortech Debugger. C++ Library Source only \$149.95 - Call for data sheet.



C++ TOOLS \$99.95

Zortech's toolkit of base C++ classes covering a wide range of common programming tasks such as bit vectors, singly and doubly linked lists, dynamic and virtual arrays, binary search tree, hash table, BCD maths, time/date/clock, directory lists, filenames, interrupt and critical error handlers, string editing, text windows and editing.

The 450 page manual also acts as a C++ tutorial which introduces the C programmer to the world of C++. Call for data sheet.

BOOKS



- C Primer (Sams) - \$23.95
- Advanced C Primer (Sams) - \$23.95
- C++ (Stroustrup) - \$29.95
- Oops & C++ (Wiener) - \$27.95

ORDER HOTLINE

1-800-848-8408

VISA/MC/COD

Prices do not include shipping

Circle 302 on Reader Service Card



Zortech, Inc., 1165 Massachusetts Avenue, Arlington, MA 02174. (617) 646-6703. Fax: (617) 643-7969.

Outside USA: Zortech Ltd., 106-108 Powis Street, London SE18 6LU, England. (44 -1)-316 7777. Fax: (44-1)-316 4138.

ANATOMY OF A LAN OPERATING SYSTEM

To understand LANs, you have to dissect the functional layers of the LAN operating system

Editor's note: Beginning this month, COMI: becomes Net/Works, a new column with a mandate to address connectivity issues across the full spectrum of system platforms and network architectures. Each month, you'll hear from industry experts on topics ranging from asynchronous communications to LANs to internetwork connectivity. We start with a look at the basics of LAN operating systems.

At the heart of every LAN is the LAN operating system. This crucial software provides the services required by network applications like E-mail. At the same time, the LAN operating system insulates those applications from the underlying network hardware. To achieve that goal, vendors construct LAN operating systems in layers. We'll concentrate on LANs for MS-DOS systems, but similar elements exist in LANs for everything from Macs to Unix machines to mini-computers like Digital's VAXes.

Basic LAN Services

At the top of any LAN operating system is a set of basic services designed to support LAN applications. All these services tend to follow the same client/server model, in which one machine—the client—needs something from another machine—the server. For example, if you want to copy a file from a remote machine, your microcomputer is a client that needs a file transfer service from the remote server.

Most early LANs required a dedicated server machine. This approach guaran-



tees that when you request something from the server, you will not affect another user's computer. Most high-performance LAN operating systems today still demand a dedicated server. This method is not mandatory, however, and in some LANs every machine can act as a server, a client, or both.

Nearly all servers, dedicated or not, supply two fundamental services: file sharing and remote printing. While these are network applications according to the International Organization for Standardization's Open Systems Interconnection model, to the user they're basic LAN operating-system services.

The ability to share files makes it possible for you to access files on another system just as if they were on your machine. LAN operating systems for different computers provide this ability in different ways. On a Mac, a remote disk appears on your screen as just another disk with its own icon. Sun's Unix Network File System (NFS), on the other

hand, makes all the remote files of a server's directory tree appear in a specified subdirectory of your root directory.

In a DOS-based microcomputer LAN operating system, you typically access remote files by treating a portion of a remote disk as your next available disk drive. For example, if your microcomputer has two disk drives and a single hard disk partition—DOS drives A, B, and C—then the remote disk partition would appear as drive D. You can treat the files on this drive just as you would any local files; you can copy them, type them, and even execute them.

Of course, before you can see drive D, you have to tell MS-DOS that you want to access a remote disk drive. The way in which you make this request varies from one LAN operating system to the next, but by way of illustration, we'll take a look at how it's done under Microsoft's MS-NET. MS-NET is a reasonable example for several reasons. First, the

continued

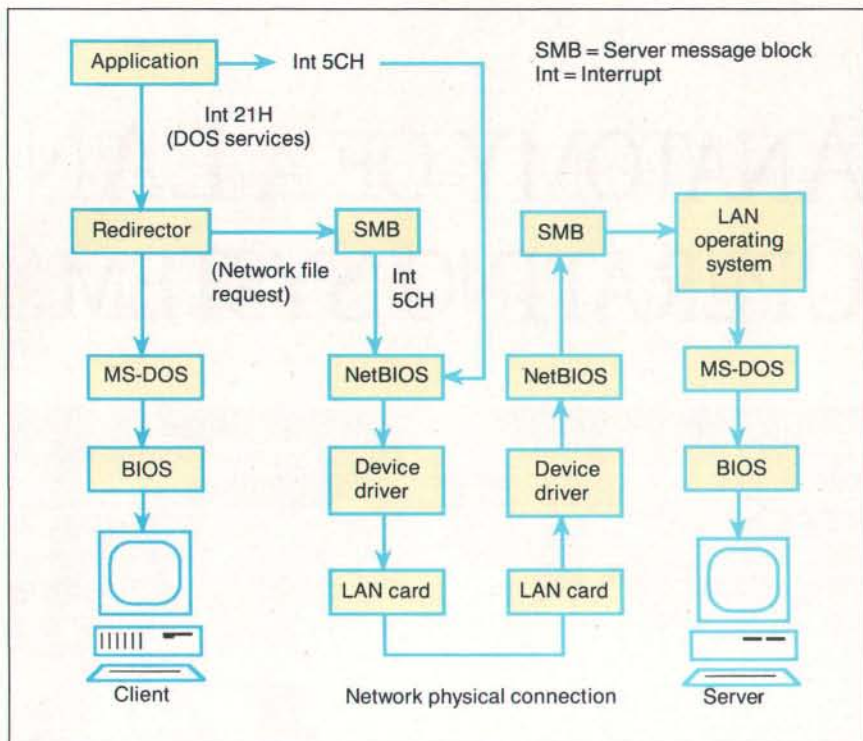

The flow of a network request from a client to a server system in an MS-Net environment.

LAN operating systems from IBM, AT&T, Digital, and 3Com all use some portion of it. Also, these and other LAN operating systems use the bulk of MS-NET's command syntax.

To map part of a remote disk to a local drive in MS-NET, you issue a NET USE command. There are several different NET USE commands, but all establish a link between the client microcomputer and the server. In order to make the files in the DIR1 directory on a server named SERVER appear as drive D, you would enter

```
NET USE D: \\SERVER\DIR1
```

This command makes the remote location of all the files on drive D transparent to you and to any applications that you execute. The LAN operating system actually hides the remote location of those files from the underlying operating system. DOS LAN operating systems, including MS-NET, hide this fact with a piece of software known as a redirector (see figure).

When an application or DOS command needs to make a file request, it eventually triggers the DOS interrupt 21H. The MS-NET redirector intercepts that interrupt before DOS gets it. The redirector checks first to see if the request-

ed DOS function is a file I/O operation. If not, the redirector passes the request to DOS's standard interrupt 21H handler.

If the request is a file request, such as an Open File or Read File operation, then the redirector checks whether that request requires a local file or a remote file. If it needs a local file, the redirector once again passes the request to the standard DOS interrupt 21H handler. If the request is for a network file, then the redirector translates that request into the format specified by the next lower level of MS-NET, the server message block (SMB) layer.

The SMB protocol lets a client request services from a server. Its services include network analogs for all the basic DOS file operations. This scheme, by the way, limits network applications to the file- and record-locking functions that DOS provides. That's good in some respects, because it means that developers can write applications that will work the same whether or not they execute over a network. But the DOS locking functions are inadequate for some sophisticated network applications, notably DBMSes. To meet the demands of such applications, many LAN operating-system vendors provide additional file- and record-locking functions.

The other major LAN operating-sys-

tem service, remote printing, works much like the file-sharing service. First, you tell MS-NET that you want to make a remote printer appear to be your local printer with a command like this:

```
NET USE LPT1: \\SERVER\LASER
```

This command maps your local LPT1: printer to the printer named LASER on the remote machine, SERVER.

When you print with a DOS command, the redirector intercepts the request just as it would a file request. It then makes the appropriate SMB calls to send the desired data to the server for printing. Unfortunately, this approach does not help the many applications that bypass DOS for printing and either call the microcomputer's BIOS print functions or talk directly to the printer. Many LAN operating systems handle the first case by intercepting the appropriate BIOS interrupt (17H) and then handling the print request as the MS-NET redirector handles a file request. That still leaves the applications that deal with the printer directly; there's nothing that the LAN operating system can do for them. Fortunately, the number of programs that go straight to the printer is decreasing all the time, so this is not as big a problem as it once was.

When a remote print or file request hits the SMB protocol, that software has to send the request to the SMB software on the server. To do so, it uses the next lower level of the LAN operating system.

Client/Server Communication

The software at this level manages the basic communication between the client and server machines. Perhaps because the services are so basic, they are often defined by the microcomputer vendors, not the LAN operating-system companies. The most prominent set of such services for DOS personal computers is defined by NetBIOS, which both IBM and Microsoft support.

Like the PC's BIOS, NetBIOS specifies a set of basic functions that higher-level programs can access. While it defines those functions, however, NetBIOS does not specify exactly how the LAN operating-system vendor has to implement them. Consequently, different LAN operating-system vendors offer different NetBIOS implementations, which can cause some network application incompatibilities.

Some of the LAN operating-system companies, such as Novell, don't even use NetBIOS to support their higher

continued

NEW...FROM PERISCOPE

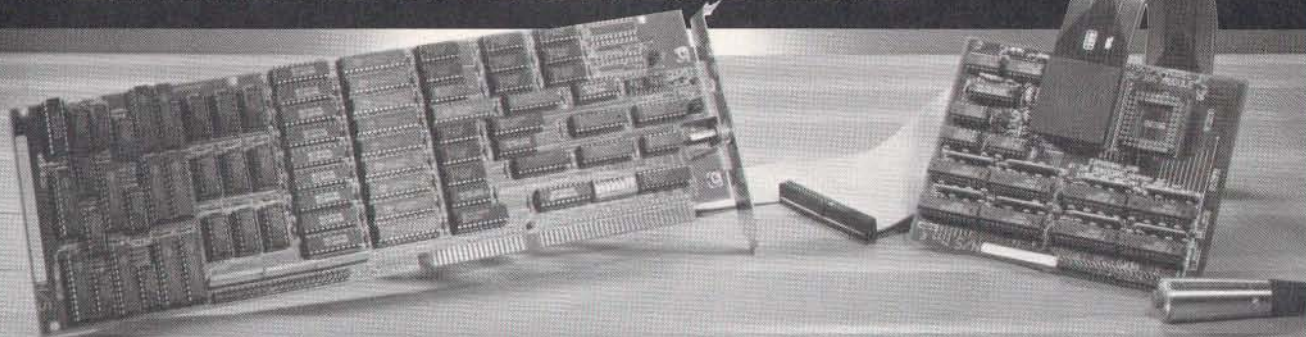

Real-Time Debugging for 386s and 286s

User Jeff Garbers, Crosstalk Communications' Director of Software Development, has been debugging with Periscope® Model IV and says, "The hardware really makes Periscope shine, especially when you've got timing-related problems. I can now track down changing pointers and altered buffers on my 386. I've been using it to debug Crosstalk® Mk. 4 and there's just no better way to do it."

Periscope IV gives you the ability to debug time-sensitive programs, hardware-interrupt routines, and programs with intermittent errors. You can run your program at full speed while tracking down unwanted memory overwrites. You can use the information captured in Periscope IV's real-time trace buffer to see EXACTLY what the system is doing, and to improve its performance.

Periscope manual, disk, quick-reference card, and 512K Plus board that provides write-protected RAM for Periscope Models I, III, and IV.



A New Generation of Hardware-Assisted Debugging

Compatible with virtually any 286 or 386 with an AT-style bus, Periscope IV works on machines running up to 25MHz with any number of wait states. Because it gets information directly from the CPU, instead of from the system bus, Model IV is not sensitive to bus compatibility issues.

Periscope IV collects CPU information in its hardware trace buffer while the CPU runs at full speed. Whether you tell Periscope IV to capture just selected information or to capture everything, you can use its powerful trace buffer commands to search for and display the execution history the way you need to see it. And you can use the CPU cycle count information to get the last bit of performance out of your code.

With Periscope IV you can set hardware breakpoints on memory accesses (within the first 16MB), I/O ports, and data. You can also set breakpoints on the occurrence of specific sequences of events, such as "watch for the routine FOO to begin executing, then while it is, watch for the variable BAR to be written." This capability, called sequential triggering, enables you to define complex conditions, then stop your program and examine what has happened when these conditions occur.

If you're developing a large application that needs all of the lower 640K, you can use the optional Plus board to keep Periscope totally out of normal DOS memory. The Plus board requires the use of a second slot.

The Periscope IV software is an extension of the software that comes with all models of Periscope. So, along with Periscope IV's powerful hardware, you get a full-function software debugger with source and symbol support for most popular PC compilers and linkers, Microsoft® Windows support, PLINK overlay support, dual monitor support, support for debugging device drivers and TSRs as well as regular programs, DOS independence, crash recovery, ease-of-use, and much more.

Prices on Periscope range from \$145 for software-only Model II-X to \$2,995 for a 25MHz 386 hardware-assisted Model IV. Call 800/722-7006 for pricing details, free information, to talk about your debugging needs, or to order your Periscope.

**Order Your Periscope, Toll-Free,
Today! 800-722-7006**

MAJOR CREDIT CARDS AND QUALIFIED
COMPANY PURCHASE ORDERS ACCEPTED



"No matter what your debugging needs, a single call to the Periscope Company has always sufficed..."

"Best of 1988" (Development Tools)
PC Magazine, January 17, 1989

The
Periscope
Company, Inc.

1197 PEACHTREE ST.
PLAZA LEVEL
ATLANTA, GA 30361
404/875-8080
FAX 404/872-1973

LAN operating-system levels. Because so many applications count on NetBIOS, however, even those vendors usually offer a NetBIOS emulator that gives applications a standard interface to the proprietary network mechanisms.

NetBIOS offers two basic kinds of communication services: session and datagram. Both are available to programs via interrupt 5CH. The session services let higher LAN operating-system layers, like the SMB, set up a link between the

client and the server that is much like a telephone call. A CALL function establishes a session, or connection, with a remote machine. SEND and RECEIVE functions let the two machines transfer data packets. When a machine receives a packet, it automatically acknowledges that fact. When the two machines are done talking, a HANG UP function terminates the session.

The datagram NetBIOS services are more like telegrams than telephone calls.

A machine can send a datagram packet (SEND DATAGRAM) without first establishing a session with the target machine, and the target machine doesn't have to acknowledge receipt of the datagram.

Datagrams are good for short messages that do not require acknowledgment. One special kind of datagram, the broadcast datagram, lets a machine send a brief message to all the other machines on the network. Broadcast datagrams are useful when a machine wants to tell all the other systems that either it or a service it provides is available. But because receiving systems need not acknowledge datagrams, datagrams do not give the sender any guarantee that its message was ever received.

For the NetBIOS to manage communication sessions and send datagrams, it must be able to talk to the underlying network hardware and the low-level protocols that hardware supports. Apple's AppleTalk LAN operating system, for one, can work with both Apple's LocalTalk and EtherTalk.

The LAN operating system interacts with the hardware via a device driver. You install this device driver in your microcomputer as you would any other device driver: with a DEVICE= line in your CONFIG.SYS file.

Device drivers hide the underlying hardware so that NetBIOS, and, therefore, the entire LAN operating system above it, can run on a wide variety of network boards. Device drivers know whether those network boards use direct memory access and what I/O ports and interrupts they expect.

The network hardware typically consists of a LAN card in each microcomputer and cabling that links the systems. The two most popular hardware connections today are Ethernet and Token Ring, although many systems also use ARCnet and Apple's LocalTalk.

When all these layers work together, the result is a LAN operating system that can support the LAN services and applications—from file sharing to remote printing to E-mail—that have made LANs an integral part of the modern computing landscape. ■

Mark L. Van Name and Bill Catchings are independent computer consultants based in Raleigh, North Carolina. You can reach them on BIX c/o "editors" and as "wbc3," respectively.

Your questions and comments are welcome. Write to: Editor, BYTE, One Phoenix Mill Lane, Peterborough, NH 03458.

TRY THIS ON A STANDARD DESKTOP PUBLISHING SYSTEM

$$\int_{-\infty}^{nZ} \frac{X^{y \cdot Z} dt}{X - tY} = \sum_{i=1}^n \left(\frac{(x^4 - i)^3}{\sqrt{Z^3 + y^{10}}} \right) \left(\frac{1}{Z - X^5 Y} \right)$$

For professional looking mathematical formulation, tables and scientific notation—no matter how complex—PCTeX is unequalled. That's why many university engineering departments and scientific societies now require papers for publication be submitted in TeX. In the world of desktop publishing systems, INFOWORD rated PCTeX #1, saying: "...No non-TeX-based program has such a comprehensive built-in grasp of typographical aesthetics..." And from PC MAGAZINE: "...You can achieve incredible precision in formatting text, especially mathematical expressions."

WHEN YOU ADD PCTeX, COUNT ON MORE THAN PRETTY NUMBERS.

TYPESET & MANUALS, FORMULAS & BOOKS
 in the same **FORMAT** or **differEnt** ONES
BIG or **SMALL** or **WIDE** or **NARROW** or **LIGHT** or **BOLD**. IT'S NICE TO KNOW PCTeX WON'T LIMIT YOUR IMAGINATION.

Finished with the formula? Then try ▲ this formatting exercise on a standard desktop system. All positioning, sizing and typesetting are done with PCTeX—no more cut'n'paste.

INFOWORD again: "...Enormously flexible and offers complete control over the output of your printer."

And with Bitstream's 30+ font families, any type of type you like is easy as ▶ **A, b, c**

PCTeX = the professional camera-ready, publisher-ready manuscripts you want.

PCTeX SUBTRACTS TIME FROM AUTHOR TO PRINTED PIECE, MULTIPLIES AUTHOR CONTROL.

For a free PCTeX demo diskette, the new PCTeX 88 product catalog and information on a PCTeX configuration for your system, give us a call at

415-388-8853

TRY IT WITH PERSONAL PCTeX INC

12 Madrona Ave. Mill Valley CA 94941

PCTeX is a registered TM of Personal TeX, Inc. TeX is an American Mathematical Society TM. Manufacturer's product names are their TMs. Inquire about PTI distributorships. Site licenses available to qualified organizations. This ad was typeset using PCTeX and Bitstream fonts.



Our Printer Sharing Unit Does Networking!

An Integrated Solution

Take our **Master Switch™**, a sophisticated sharing device, combine it with **MasterNet™** networking software for PCs, and you've got an integrated solution for printer and plotter sharing, file transfer, electronic mail, and a lot more. Of course you can also share modems, minis, and mainframes or access the network remotely. Installation and operation is very simple.

Versatile

Or you can use the Master Switch to link any computer or peripheral with a serial or parallel interface. The switch accepts over 20 commands for controlling the flow of data. It may be operated automatically, by command, or with interactive menus. Its buffer is expandable to one megabyte and holds up to 64 simultaneous jobs. The

MasterLink™ utility diskette for PCs comes with every unit and unleashes the power of the switch with its memory-resident access to the commands and menus.

Other Products

We have a full line of connectivity solutions. If you just want printer sharing, we've got

it. We also have automatic switches, code-activated switches, buffers, converters, cables, protocol converters, multiplexers, line drivers, and other products.

Commitment to Excellence

At Rose Electronics, we're not satisfied until you're satisfied. That's why we have thousands of customers around the world including large, medium, and small businesses, factories, stores, educational institutions, and Federal, state, and local governments. We back our products with full technical support, a one-year warranty, and a thirty-day money-back guarantee.



ROSE
ELECTRONICS

Call now for literature or more information.
(800) 333-9343

Give a Rose to your computer



4800 Bits, No Errors

Unless you're racing down the Bonneville Salt Flats or jousting for a parking space in Manhattan, some things are more important than speed. In data communication, raw speed without sophisticated control can lead to disaster. No one will argue that fast modems are needed—especially when every minute of connect time translates to dollars and cents. But what's the point of screaming through a high-speed transfer if you lose half your data along the way?

Modems can use compression and correction algorithms to double effective throughput while delivering error-free transmission. But they need even more than speed and accuracy—they must also conform to existing designs and planned standards. And, of course, an attractive price tag always helps.

This month, the BYTE Lab examines 17 external 2400-bps modems equipped with data compression and error correction. Our specific requirements for this review were compatibility with V.22bis (the CCITT standard for 2400-bps modem transmission), some form of error correction, and data compression with a rated throughput gain of 2 to 1 or better.

Alphabet Soup of Standards

Modern modems are often much more than the simple modulators/demodulators that their name implies. At the basic level, all modems convert digital information to analog signals for transmission within the bandwidth of the telephone line. Most modems that are designed for microcomputers, like those in this review, contain additional hardware: an asynchronous/synchronous converter, intelligence for command interpretation, automatic dialing and answering, and memory for configuration storage.

The CCITT's V.22bis recommendation sets the ground rules for 2400-bps modem-to-modem communication. It specifies the data transfer rate, the mod-

2400 bps
2400 bps
2400 bps
2400 bps
2400 bps
2400 bps
4800 bps
4800 bps
4800 bps
4800 bps
4800 bps

ulation scheme, and the duplexing technique. This imposed standard ensures that different manufacturers' modems will communicate without difficulty.

V.22bis modems use 16-point quadrature amplitude modulation (QAM) to convert data signals. Each group of 4 bits is encoded as a combination of phase and amplitude changes in carrier component signals. These modems achieve full-duplex transmission by separating the carriers in frequency; one modem's carrier is at 1200 Hz, while the second is fixed at 2400 Hz. With this division, both modems can simultaneously transmit over a two-wire line at the nominal rate of 2400 bps. [Editor's note: *For more background on modulation techniques, see this month's Under the Hood column, "Modern Modem Methods" by L. Brett Glass on page 321.*]

Most of us no longer consider 2400 bps

fast, but V.22bis modems squeeze a great deal of information through the limited bandwidth of the telephone line. Unfortunately, limited bandwidth is not the only hurdle to overcome; the public switched telephone network (PSTN) often introduces other barriers to accurate communication. Noise is but one of the significant contributors to error.

The oft-quoted 3002, C2, and C4 telephone-line specifications refer to the different degrees of attenuation distortion and envelope delay distortion. Attenuation distortion interferes with a signal by providing different levels of attenuation at different frequencies; similarly, envelope delay distortion introduces unequal phase changes at different frequencies.

Other error factors—echoes, phase jitter, intermodulation distortion, frequency offset, and gain and phase hits—can have a significant effect on some connections.

Error correction has been available on high-speed modems for some time, and most of us are familiar with software error-correction protocols. Software protocols have a few limitations: You can't use them for interactive sessions where you're typing at the keyboard, and you can use them only if the remote location activates the protocol at the same time. Hardware-implemented error correction can proceed whenever two modems support the same technique. Since most of these modems can take synchronous as well as asynchronous inputs, these protocols can be used in microcomputer-to-mainframe links.

Two hardware error-correction techniques have gained wide acceptance: X.25 and the Microcom Networking Protocol. The X.25 standard is a CCITT protocol recommendation for packet-switched networks, and MNP is a point-to-point protocol developed by Microcom. Both rely on cyclic redundancy checking (CRC) to detect errors. The MNP protocol is more relevant in this discussion of dial-up modem-to-modem

With error correction and data compression, these 2400-bps modems pack double the data

Steve Apiki and Stanford Diehl

communications, but X.25 serves as the basis for both Telcor's proprietary correction and compression scheme and X.PC, a popular protocol used by Tymnet.

The CCITT's recent V.42 recommendation for error control is also similar to X.25. Although V.42 may emerge as a broadly supported standard, as of this writing, only Hayes is shipping a 2400-bps V.42 modem. The protocol comes with some support already in place: All V.42 modems must accept MNP connections if native LAP-M is not available on both ends. This means that modems supporting either MNP or V.42, as all the modems in this review do, will remain compatible with the majority of installed modems for quite some time.

MNP is divided into classes. Classes 1 and 2 are asynchronous protocols and are rarely used. Classes 3 through 5, like X.25 and V.42, are synchronous bit-oriented protocols. They use a 16-bit CRC polynomial on 64-character blocks to detect errors. Since they are synchronous, they don't need the framing bits used in asynchronous transmission. By tacking a start bit and a stop bit onto each 8-bit stream, asynchronous transfer adds a 20 percent overhead to each transmission. Eliminating these framing bits results in increased throughput. Each protocol

adds some bit overhead for error correction, but the additional bits amount to less than the 20 percent savings. The net result is error-free transmission with increased throughput.

Modems supporting class-4 protocols outperform class-3 modems because they use larger blocks and an improved header with fewer bits. Class 4 modems dynamically adjust block lengths to adapt to line conditions. Shorter blocks increase efficiency when poor lines demand retransmission, while longer blocks enhance throughput over clean channels. Class-4 modems can pass up to eight blocks before requiring an acknowledgment.

Modems that support V.42 or MNP classes 3 or 4 have better than 100 per-

cent efficiency; however, the way they achieve this is by eliminating asynchronous overhead and not by compressing the data itself. The majority of these modems employ MNP-5 data compression to reduce the number of bits required to send a given amount of data. Hayes uses a proprietary technique, and Telcor offers both MNP-5 and its own algorithm. The CCITT has not yet completed its V.42bis standard for data compression.

MNP-5 data compression uses run-length encoding and modified Huffman codes in order to achieve compression. Run-length encoding reduces repeated characters to a character symbol and a repetition symbol. As a simplified example, run-length encoding would reduce "AAAAA" to "5A," a much shorter string.

Huffman coding uses fewer bits to encode frequently recurring characters. For English text, the letter *e* could be coded with 2 bits, while the much less common *q* might be coded with 10. The MNP protocol tracks the frequency of characters used in each transmission and adjusts its encoding tables on the fly; effectiveness is not limited to one type of file.

These compression enhancements let you transfer data at greater than the

continued



Top of the Line:

(Clockwise from upper left): Fastcomm FDX 2448, Hayes V-series Smartmodem 2400 V.42, Telcor 2496MA, and E-Tech Bullet E2400M.

Table 1: Price, performance features, enhancements, and compatibility of modems tested (● = yes; ○ = no).

Modem	Price	COMPATIBILITY							
		Bell 103	Bell 212A	V.21	V.22	V.22bis	MNP levels	ENQ/ACK	Other
Concord Data Systems 224 Series II	\$875	●	●	○	●	●	2-5	●	
Data Race Action 24	\$595	●	●	○	●	●	2-5	●	
E-Tech Bullet E2400M	\$395	●	●	○	●	●	1-5	●	
Fastcomm FDX 2448	\$649	●	●	[●]	[●]	●	1-5	●	
General DataComm 224E/MNP	\$495	●	●	○	●	●	1-5	○	
GVC Model SM24M	\$359	●	●	○	●	●	1-5	○	
Hayes V-series Smartmodem 2400 V.42	\$899	●	●	○	●	●	N/A	○	V.42, Hayes data compression
Inmac Clear Signal 2400 SD+	\$269	●	●	●	●	●	5	○	
Microcom AX/2400c	\$699	●	●	○	●	●	2-5	●	
Multi-Tech MultiModem224E MT224EH	\$599	●	●	[●]	●	●	2-5	●	
Racal-Vadic 2400VP	\$595	●	●	○	○	●	2-5	○	
Telcor 2496MA	\$895	●	●	○	●	●	1-5	●	Telcor
Telenetics TC921S-24	\$695	●	●	[●]	●	●	1-5	○	
Universal Data Systems 2440	\$550	●	●	○	●	●	2-5	○	
USRobotics Courier 2400e	\$699	●	●	○	○	●	1-5	○	
Ven-Tel EC2400-33	\$595	●	●	○	●	●	1-5	○	X-PC
Western Datacom 424 Class 5	\$595	●	●	○	●	●	1-5	○	

¹ Key to other modes: S = synchronous operation, LL = leased-line capability, 4W = four-wire operation.

² AutoSync (AS), along with Hayes Synchronous Interface (HSI) software, allows the modem to communicate synchronously without an adapter card.

³ 7680 bytes translates to 32 pages, the equivalent of 698 passwords, 333 phone numbers, or 144 option sets.

⁴ Error control buffer/other buffer.

[] = Optional feature.

N/A = Information not available from manufacturer.

N = Numbers.

C = Configurations.



Western Datacom

modem-to-modem bps speed. You simply establish a compatible link, set the computer-to-modem speed to at least 4800 bps, and fire away. (Note: The computer is also known as data terminal equipment, or DTE, and the modem is also known as data communication equipment, or DCE.) Each modem buffers data from the DTE, compresses it, and sends it over the phone line. If the rate is too high, the buffer will fill, and the modem may need to control the flow

of data from the DTE, using either the RTS/CTS lines or software (XON/XOFF) characters. This configuration—with the DTE sending as fast as it can to the modem, keeping the buffers nearly full—is ideal for data-compression modems; slower DTE speed can limit compression and choke throughput.

Command Sets and Compatibility

The Hayes AT command set has become a fixture in the modem marketplace. Almost any modem, including every one in this review, implements this standard. The standard AT set includes many basic features, such as auto-answer, redial, reverse dial (dial in the answer mode), last-number recall, and status displays. All the vendors except Hayes also offer a set of MNP enhancements to control such options as data compression and auto-reliable mode. Auto-reliable mode will detect a non-MNP modem on the remote end and switch to a normal connection.



Microcom

Proprietary command set additions also trigger special features like number linking and continuous redial (see table 1 above). With number linking, you can string stored phone numbers together; if one line is busy, the modem will automatically ring the next number in the string. Another response to busy lines, continuous redial, will ring the line until a successful link is made or until completing the maximum number of tries. These features are handy, but you can

BUFFERS			Other storage	Other modes ¹	Remote config.	Call-back security	Continuous redial	Number linking	Manual indexed	Warranty (years)
Transmit (bytes)	Receive (bytes)	Number (chars.)								
2K	2K	80	10 N	S,[LL],[4W]	●	○	○	○	●	2
1K	1K	68	10 N 3 C	S,LL	●	●	○	●	●	1
24-30K	Total	40	10 N	S,LL	○	○	○	○	○	2
4K	4K	48	4 N	S,LL,[4W]	●	○	●	●	○	2
2K	2K	40	10 N	S,LL	○	○	○	●	●	1
256	256	40	4 N 2 C	S,LL	○	○	○	○	○	2
N/A	N/A	255	4 N 2 C	S,LL,AS ²	○	○	○	○	●	2
N/A	N/A	40	4 N 2 C	S	○	○	○	○	○	2
600	600	80	9 N 4 C	S,LL	●	○	○	●	●	1
2K	2K	40	10 N	S,LL	○	○	●	●	○	2
2K	2K	40	15 N	S,LL	○	○	●	●	○	2
2K	2K	70	7680 bytes ³	LL	●	●	○	○	●	3
1K	1K	40	32 N 9 C	S,LL,4W	●	●	○	○	○	5
1K	1.25K	80	5 N 6 C	S,LL	○	○	○	○	○	1
3.5K/5K ⁴	2K	40	1 N	LL	○	○	●	○	●	2
2K	2K	40	9 N	S,LL,4W	○	○	●	●	●	5
2K	2K	64	8 N 2 C	S	●	●	○	○	○	1



General DataComm

usually get them from your communications software.

Some of the vendors include only the standard command set, opting for alternate ways to embellish features. The Racal-Vadic 2400VP's asterisk prompt enables many handy features with a set of single-letter commands. You can link numbers by entering an L, or you can access various memory locations for stored number dialing. This works hand in hand with full manual control of talk/

data, transfer speed, auto-answer, data format (synchronous or asynchronous), and self-test loops. Similarly, the Ven-Tel EC2400-33 enters a command mode from the dollar (\$) prompt.

The Telcor 2496MA enhances the interface with full menu control. You can step through the menus by entering responses from the terminal or from touch keys. A touch-key combination displays available options, while another key advances through each selection. In this way, you have a full view of all parameters as well as an easy way to change each setting. The Telcor 2496MA also delivers advanced feedback through a numeric display panel and coded responses.

A menu system also drives the Universal Data Systems 2440. Seven main menus control configuration, protocols, testing, and dialing of stored numbers. An LCD prompts you, and you respond from the touchpad with simple "yes" and "no" input. You can lock the front panel



USRobotics

to prevent unauthorized access.

Experienced users may find menu overlays intrusive. After all, the AT command set is simple and direct. Still, a stark screen awaiting commands can be intimidating, and unless you've memorized the full AT repertoire, a comprehensive interface makes configuration chores less trying. When you're reviewing options to ensure compatibility with a remote site, that can save you from some

continued



GVC



Inmac

headaches. The modems from Concord Data Systems, Data Race, Fastcomm, Microcom, Telcor, Telenetics, and Western Datacom make remote configuration even easier by letting you configure a remote modem from the local keyboard.

It takes more than a standard com-

mand set to ensure compatibility. Compatibility, though, is a tricky question with this set of modems. They can all speak MNP, except the Hayes 2400 V.42, which cannot decipher level-5 data compression. Yet, with V.42 sure to become a standard, the Hayes modem has a leg up on the competition. Since no other 2400-bps V.42 modems exist, we didn't run V.42 compatibility tests on the Hayes modem. Data Race and Universal Data Systems told us that their 2400-bps modems can be upgraded to V.42 when it becomes available. Ven-Tel includes support for X.PC. Modems from Concord Data Systems, Data Race, E-Tech, Fastcomm, Microcom, Multi-Tech, and Telcor are also compatible with equipment that employs Hewlett-Packard ENQ/ACK pacing.

Securing the Lines

These modems offer a range of security options to suit your needs. The modems with remote configuration will usually restrict the level of remote access. At one level, a remote user can view configuration parameters but cannot change them. At the next level, the remote user can

Figure 1 (at right): Power of the pump. The typical line ASCII transfer reflects the quality of compression, while the binary transfer more closely represents the efficiency of the data pump. Transfers across the impaired line test error-correction capability. The bottom bar maps performance under MNP-4. Missing segments indicate transmission failure.

	dBASE	ASCII	Binary
Typical			
Impaired			
MNP-4			

change the configuration. In addition, the Microcom, Concord Data Systems, Data Race, Fastcomm, and Western Datacom modems can require a log-in password to restrict caller access.

The dial-back feature represents a higher level of modem security. When the modem receives a call, it accepts a valid password from the caller, hangs up, and calls the remote modem back. The

continued

A Less Painful Route to 386SX Performance

Upgrade to 386SX Power with 2 MB Ram for only \$995.00!

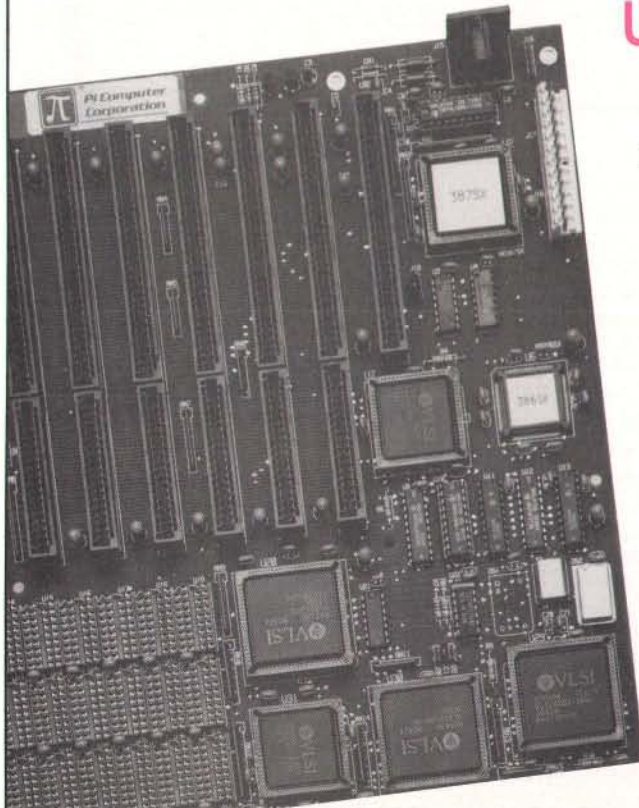

Featuring:

- 16 Mhz CPU with 6 AT and 2 XT Slots
- 387SX and Shadow BIOS Support
- Choice of Award™ or Phoenix™ BIOS
- Expandable to 8 MB on-board RAM
- Three year parts & labor warranty
- 45 day money back guarantee
- 286 and 386 motherboards, RAM, Drives, Cases, P/Ss, Add-in Cards, and Full Systems ARE Available



Call Today at 800-666-9248

Pi Computer Corporation

Your Best Value in Motherboards*

P.O. Box 68, Earlysville, VA 22936
804-978-3917 • Fax: 804-978-3906
Visa, MC and AM-EX Accepted

* Since 1983

© 1989 Pi Computer Corp.

2400-BPS MODEMS

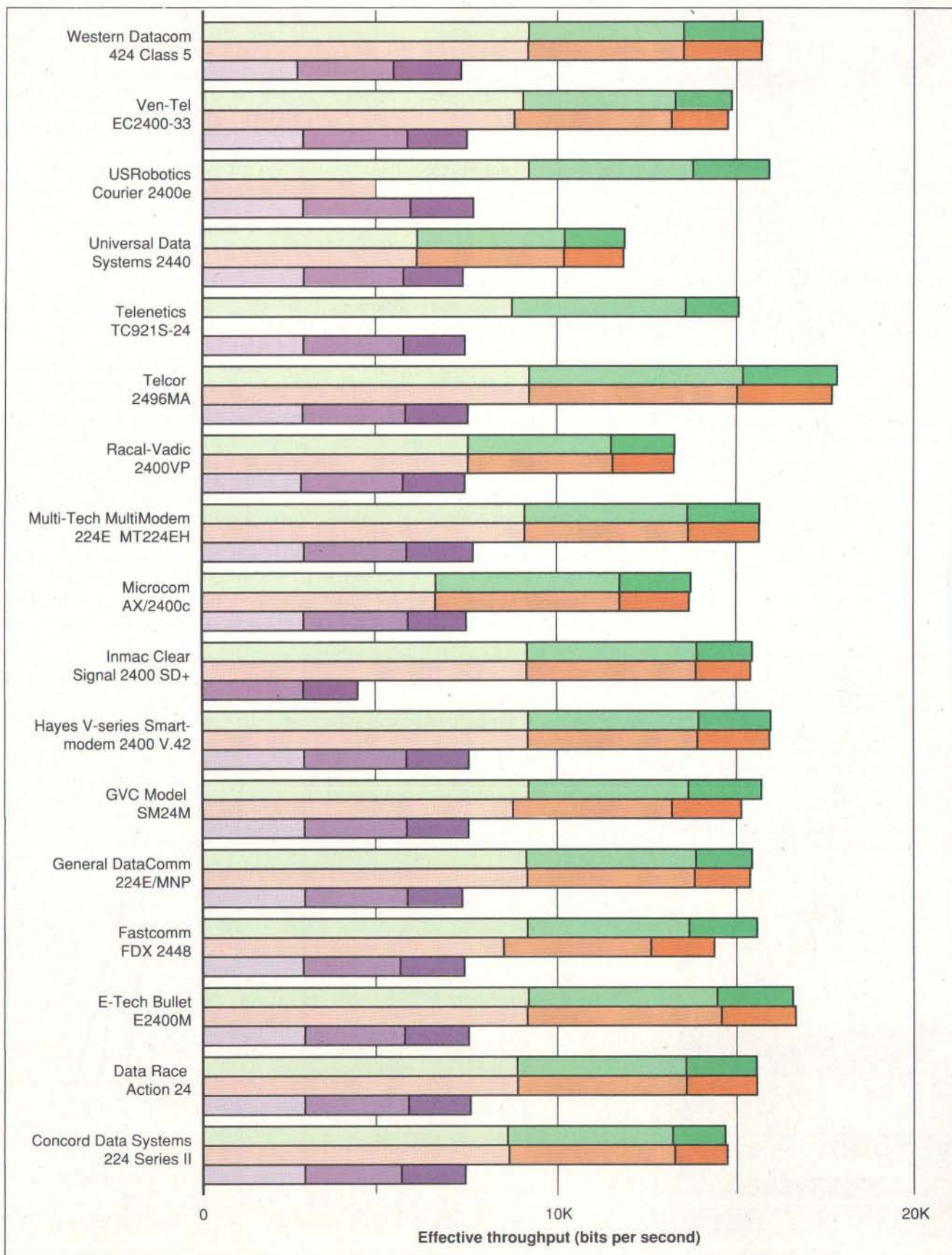



Multi-Tech



Telenetics

host modem can either prompt the remote user for a phone number or pull a specified number from storage. The password determines your level of access. And if you're really paranoid, a Telcor upgrade delivers data encryption.

In fact, the Telcor 2496MA supplies a full set of security options: An internal password table assigns features depending on the user log-in; access codes determine four levels of local access and

two levels of remote access; and a 17-digit master key number composes an encryption key between two accelerators. Telcor's impressive storage capacity lets you store up to 698 passwords or 350 passwords with associated call-back strings.

The Performance Factor

The ultimate performance measure for these modems is throughput. It reflects the level of data compression, the speed and adaptability of error correction, and reaction to line impairments. As long as the modems transfer without errors, we can easily make consistent comparisons. All the modems met this basic criterion. (See the text box "Performance Tests" on page 170.)

The typical line results shown in figure 1 are probably the best indicators of everyday performance. They also point out the difference in relative compressibility between the three test files. ASCII text best reflects the quality of compression; most of the modems had a gain in throughput of about 2 to 1. As expected, none of the modems compressed the random data of the executable file very well. Sent with the small-block XMODEM protocol, the binary file rep-

resents a worst-case transfer. The highly compressible dBASE document, containing data formatted into fixed-length fields, represents the other end of the spectrum. The dBASE file transferred with YMODEM-G is close to the best case, and every modem achieved at least 3-to-1 compression.

The Telcor 2496MA proved outstanding on both the typical and impaired lines. The performance bars shown in figure 1 are for the Telcor modems using Telcor's proprietary compression method; these levels of throughput are possible only with two Telcor modems. We did not graph Telcor performance in MNP-5-compatible mode; it ran about as fast as the Multi-Tech modem.

The power of the E-Tech Bullet E2400M surprised us, given its modest price. It had the second-best ASCII transfer rate and the second-best overall rate on all tested lines. Hayes's V.42 modem with proprietary compression method had better than average throughput for all file types. Some other modems from big-name manufacturers, including Universal Data Systems, Racal-Vadic, and Microcom, turned in disappointing results.

We were forced to test the Inmac Clear Signal modem using XON/XOFF flow

Figure 2: Plotting the performance curve. Lines starting high on the bps axis reveal outstanding throughput, while those that stretch farthest along the signal-to-noise-ratio (SNR) axis display impressive resistance to noise. The Telcor 2496MA transferred at sizzling speeds but fizzled when the lines turned dirty. The Racal-Vadic 2400VP boasts the best SNR. Note the nonlinear bps axis (the scale was adjusted for clarity).



Universal Data Systems

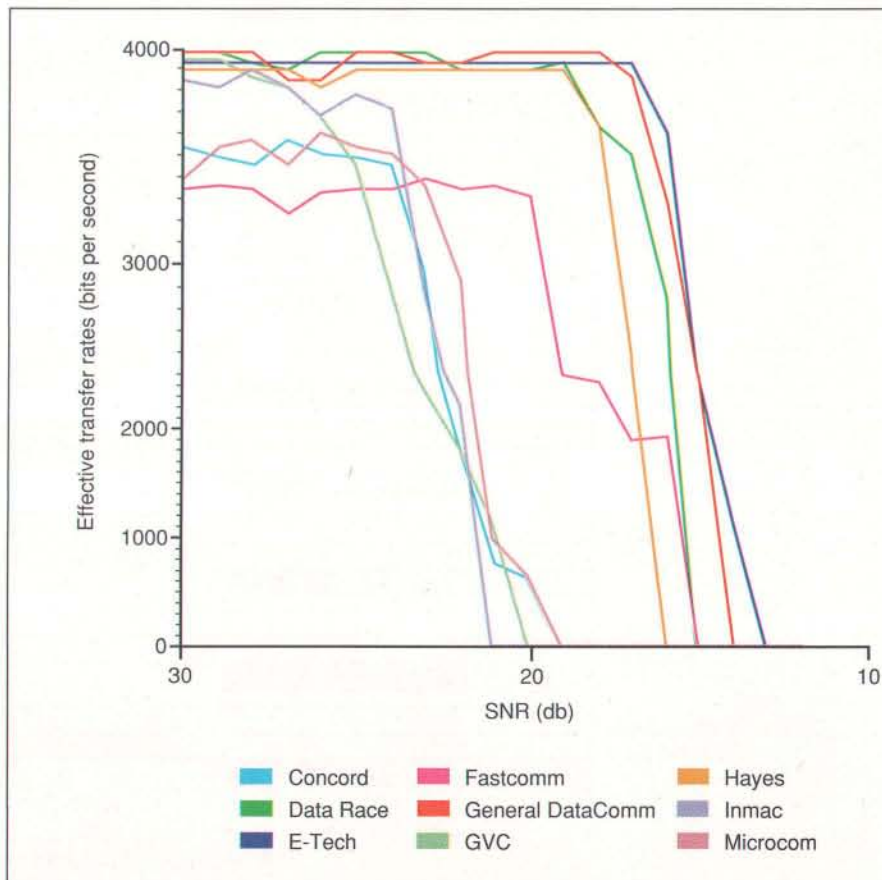

2400-BPS MODEMS

control for the ASCII file because the modem's hardware flow control implementation does not work. Inmac called the problem a "known bug" in firmware, and the company is working on a solution. We ran the protocol transfers with flow control disabled.

For most modems, performance was about the same on the impaired lines as it was on the typical line. We used a preliminary draft of EIA-496A to set up the impaired lines. (You can modify the impairment channel specifications of EIA-496A in the final document.) Because the EIA lines stress several different impairments, consistent performance on all of them suggests that a modem can handle almost any real line. Only two of the modems failed to connect on all the impaired lines, and they failed only on EIA-4. On the other four impaired lines, they performed at about the same level as they did on the typical line.

MNP-4 throughput, the last box in figure 1, shows almost no performance difference from modem to modem, so we attributed most of the throughput differences to the data-compression implementation. The Inmac modem could not complete the YMODEM-G protocol transfer without data compression be-

cause it lacked proper flow control (XON/XOFF can't be used reliably for protocol transfers). Therefore, no results for the Inmac transferring the dBASE file are shown.

The test we used for non-error-cor-
continued



Data Race



Ven-Tel

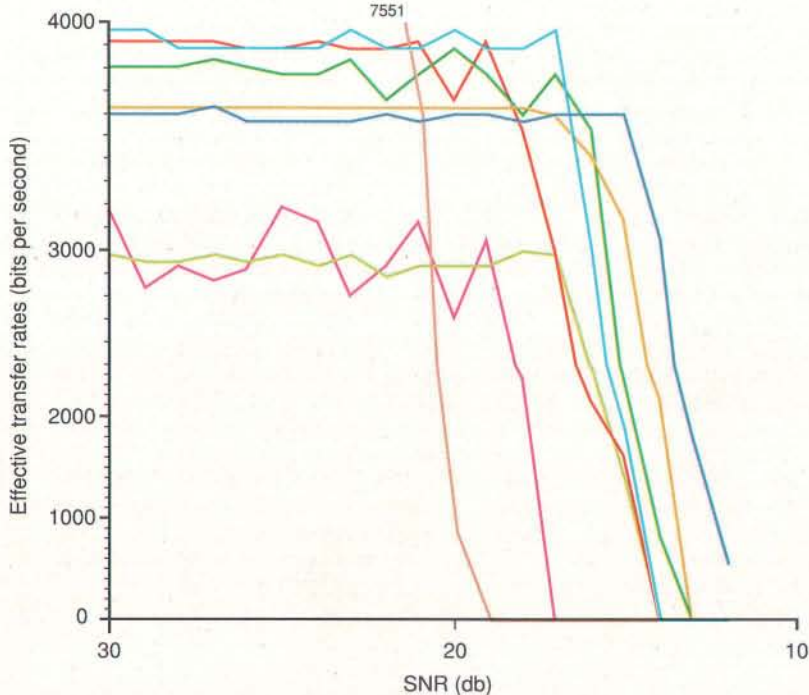

- Multi-Tech
- Telenetics
- Ven-Tel
- Racal-Vadic
- Universal Data Systems
- Western Datacom
- Telcor
- USRobotics

How One May Stop Writing Passively.

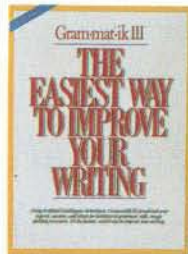

Writing in "passive voice" is wordy and indirect. But it's hard to detect. Unless you have

Grammatik III. Grammatik III is IBM PC software that makes it easy to replace "passive voice" with direct, action-oriented writing... right away.

Grammatik III uses Artificial Intelligence to proofread your writing for errors in grammar, style, usage, and punctuation. Along with "passive voice," it checks for split infinitives, incomplete sentences, improper verb usage, and much more. As it checks, it shows writing errors in context, right on your screen. Then it offers suggestions for improvement and lets you revise your document immediately, without going back to your word processor. It's really that easy.



Memos, letters, reports... everything WILL be clearer and more concise *or your money back*. * So order Grammatik III now, risk-free for only \$99 (network edition \$189), and improve your writing today.

CALL NOW!! (800) 872-9933

Gram·mat·ik III™

Powerful Writing Improvement

*Try Grammatik III risk-free. If not completely satisfied, return it within 30 days for a full refund. Novell Network Edition is for up to five users. Grammatik is a trademark of Wang Laboratories, Inc. © 1989 Reference Software, Inc., 330 Townsend St., Suite 123, San Francisco, CA 94107

Performance Tests

Speed, compatibility, robust execution on noisy lines—all are critical in evaluating performance. We developed a group of tests to isolate and compare each of these critical factors.

Our first suite of tests focuses on a modem's ability to compress data in three file formats: ASCII text, database, and binary. The ASCII document represents the type of file most often transferred without resorting to a software protocol, while the other two contain non-ASCII characters and are usually sent using some form of packet conversion.

For the ASCII test, we used a 32K-byte file containing the text of a BYTE article. The document, though mostly (about 75 percent) nonrepeating English text, included some tables of words and numbers. Our 246K-byte database file was a mailing list created with dBASE III Plus. CC86.EXE, the 39K-byte BYTE Small-C compiler, represented a typical binary executable file.

Because software protocols can have a profound effect on overall throughput, we tested these modems using two of the most common: XMODEM and YMODEM-G. Virtually every communications package supports the widely popular XMODEM protocol, which performs a cyclic redundancy check (CRC) or checksum block error checking on 128-byte blocks. While less prevalent, the YMODEM-G protocol operates on larger, 1K-byte blocks and does no independent error detection, making it ideal for error-correcting modems.

We combined protocols and file formats into one test by sending the database file with YMODEM-G and the binary file via XMODEM CRC. The ASCII file was sent without software protocol.

For these tests, our data terminal equipment (DTE) was two identically equipped 12.5-MHz Dell 200s running Procomm Plus. We set up a Procomm script file to time the transfer of each file; each file was sent to and from a RAM disk to minimize the systems' ef-

fect. To find errors in the received files, we wrote a compare utility to check them byte by byte against known good files transferred with the same protocol.

The heart of the test setup was an Autotest switched-line simulator. The unit houses a switched-line simulator, a hybrid transformer, a four-wire impairment channel, and a four-wire attenuator. The switched-line simulator looks to each modem like an ordinary telephone line; it provides loop current and rings the target modem when a call is placed. Transmitted signals pass from the two-wire switched-line simulator through the hybrid into the four-wire impairment channel. The impairment channel can provide noise, attenuation distortion, envelope delay distortion, phase jitter, nonlinear distortion, gain hits, and frequency offset. On the other side of the impairment channel lies another hybrid, another switched-line simulator, and, finally, the receiving modem. Signals sent by the receiving device (e.g., acknowledgments and checksums), while following a similar path back to the transmitter, pass through a simple attenuator rather than through the impairment channel.

For our typical-line throughput test (figure 1), both transmit and receive modems were similarly configured units of the model under test. Each modem had data compression and bidirectional hardware flow control enabled and required an error-correcting link. Procomm set the DTE speed to 9600 bps but did not introduce any line or character delays during the ASCII transfer. The simulator presented a typical line channel to each modem, with 16-decibel 1004-Hz loss and -52 dB_m (decibels referenced to 1 milliwatt) injected noise, and the modems made connection at 2400 bps. If the modems could not establish an error-correcting link, they dropped the carrier and canceled transmission.

All our results are graphed as effective throughput rates in bits per second.

These were calculated from the size of each file (bits transferred = bytes \times 10) and the times recorded by the Procomm script. Procomm reports times in seconds, and since the shortest time for any file transfer was on the order of 50 seconds, our margin of error is about ± 1 percent.

The impaired line results are an average of a modem's performance over five lines specified by the preliminary draft of EIA-496A. The document gives recommendations for standard impairment combinations to be used in testing dial-up modems. Each of the five lines stresses one impairment type over others; EIA-1, for example, has particularly high phase jitter, while EIA-2 has a low receive level and severe attenuation distortion. EIA-4, which seems to be the most difficult, features a very low receive level, large envelope delay distortion, and some frequency translation.

We also tested modem compatibility. Figure 1 shows the results for each modem connected over a typical line to a Microcom modem running MNP-4. The graphs present an average of transmit and receive performance. As an additional compatibility test, we linked each modem with a Hayes Smartmodem 2400, which has neither error correction nor data compression.

Our final test generates a plot of effective throughput versus signal-to-noise ratio (SNR) as a measure of sensitivity to noisy lines (figure 2). Two modems of the type under test were set for data compression and connected over a 3002 channel. We used the Autotest's simulated DTEs to repeatedly generate a 60-character message ("The quick brown fox...") and to test for transmission errors on the receive side. We began the test with noise at -79 dB_m and then held every other parameter constant while increasing the amount of noise injected into the channel. Both DTEs sent and received 40,000 characters at each SNR level with the modems operating at 2400-bps full duplex.

rected V22.bis compatibility has no corresponding graph. Except for one trouble spot, all the modems proved compatible, and throughput performance from modem to modem was almost indistinguishable. The problem occurred with the GVC Model SM24M, which had

trouble receiving the YMODEM-G transfer file from the Hayes Smartmodem 2400 that we used as a control. This left us unable to complete the transfer.

Figure 2 tracks the results of our noise-versus-throughput test. The best curve encloses the most area, but there's

often a trade-off between high throughput under normal conditions and noise resiliency. Racal-Vadic's 2400VP can transmit on lines that are too noisy for any other modems, but it suffers from slow throughput on everyday lines.

continued

Not only does Telebit make the world's fastest modems, we also endorse your checks.

If you're looking for a high-speed, dial-up modem that endorses industry standards and more, check out the Telebit® T2500.

As well as transmitting data error-free at a lightning-fast 19,200 bps with Telebit's PEP™ modulation, the T2500 also adds V.32 to its modulation list. That means you can automatically use the CCITT V.32 standard for synchronous or asynchronous connections.

So, for large-volume or interactive transmissions, you won't find a better modem than the Telebit T2500. It supports all major modem standards, and is ideal for connecting micros to LANs or mainframes. Plus it easily handles international transmissions. And speaks fluently with more dial-up modems than any other.



In addition to the industry's highest data rate, Telebit's multicarrier PEP technology makes hang-ups and bad line problems a thing of the past.

To find out more about the world's fastest modem, call 1-800-TELEBIT today. Or write us at 1345 Shorebird Way, Mountain View, CA 94043-1329. Phone: (415) 969-3800.

Learn why no one gets the message through like Telebit.



© 1989 Telebit is a registered trademark and PEP is a trademark of Telebit Corp. MNP is a registered trademark of Microcom, Inc. Other product names are trademarks of their respective holders.

In Europe call Luxembourg +352-31-96-45

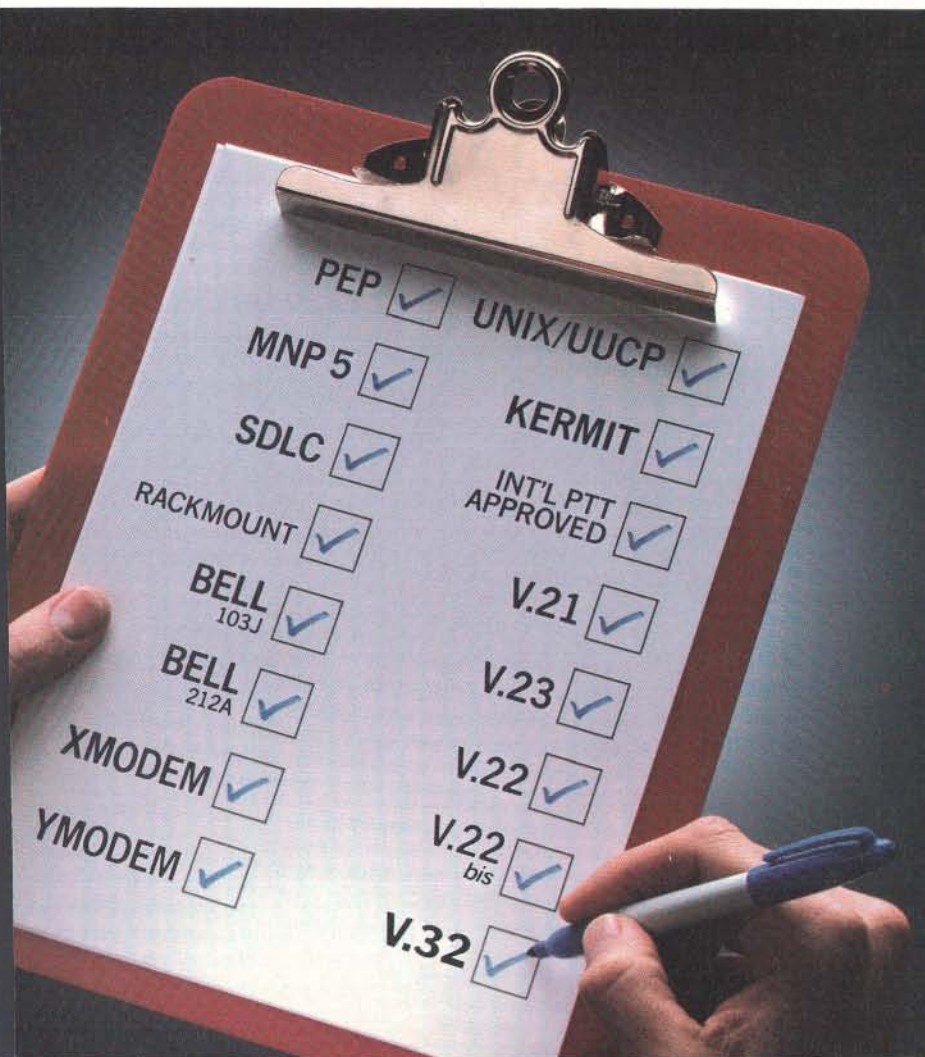

- PEP
- MNP 5
- SDLC
- RACKMOUNT
- BELL 103J
- BELL 212A
- XMODEM
- YMODEM
- UNIX/UUCP
- KERMIT
- INT'L PTT APPROVED
- V.21
- V.23
- V.22
- V.22 bis
- V.32

COMPANY INFORMATION

Concord Data Systems
45 Bartlett St.
Marlborough, MA 01752
(508) 460-0808
Inquiry 1071.

Data Race
12758 Cimmaron Path,
Suite 108
San Antonio, TX 78249
(512) 692-3909
Inquiry 1072.

E-Tech Research, Inc.
2700 Augustine Dr.,
Suite 275
Santa Clara, CA 95054
(408) 982-0270
Inquiry 1073.

**Fastcomm
Communications Corp.**
12347-E Sunrise Valley Dr.
Reston, VA 22091
(703) 620-3900
Inquiry 1074.

General DataComm
1579 Atraits Tpk.
Middlebury, CT 06762
(203) 574-1118
Inquiry 1075.

GVC-Chenel Corp.
99 Demarest Rd.
Sparta, NJ 07871
(201) 579-3630
Inquiry 1076.

**Hayes Microcomputer
Products, Inc.**
705 Western Dr.
Norcross, GA 30092
(404) 449-8791
Inquiry 1077.

Inmac
2350 Zanger Rd.
San Jose, CA 95131
(408) 435-1700
Inquiry 1078.

Microcom, Inc.
500 River Ridge Dr.
Norwood, MA 02062
(617) 551-1000
Inquiry 1079.

Multi-Tech Systems, Inc.
2205 Woodale Dr.
Mounds View, MN 55112
(800) 328-9717
Inquiry 1080.

Racal-Vadic
1525 McCarthy Blvd.
Milpitas, CA 95035
(408) 432-8008
Inquiry 1081.

Telcor Systems Corp.
12 Michigan Dr.
Natick, MA 01760
(508) 653-3995
Inquiry 1082.

Telenetics
5109 East La Palma Ave.
Anaheim, CA 92807
(714) 779-2766
Inquiry 1083.

Universal Data Systems
5000 Bradford Dr.
Huntsville, AL 35805
(205) 721-8000
Inquiry 1084.

USRobotics, Inc.
8100 North McCormick Blvd.
Skokie, IL 60076
(312) 982-5001
Inquiry 1085.

Ven-Tel, Inc.
2121 Zanker Rd.
San Jose, CA 95131
(408) 436-7400
Inquiry 1086.

Western Datacom
8431 South Ave.
Youngstown, OH 44514
(216) 758-9588
Inquiry 1087.



Racal-Vadic

The Telcor 2496MA, again, had outstanding throughput, but it was weak in handling noisy lines. Telcor's proprietary compression algorithm easily compacted the short, repeating message. For comparison, we also ran the Telcor units using MNP—they had a slightly worse reaction to noisy lines, and throughput close to that of the Data Race Action 24.

We had a little difficulty getting the Telenetics TC921S-24 to run the noise test. The graph shows the erratic performance from noise level to noise level. Flow control was also erratic; the modem would occasionally lock up and never raise the CTS (clear to send) signal. Sometimes it would hang up during the middle of transmission. Telenetics said it

could not duplicate the problem in its lab, but the company continues to work on our observation.

Bits for the Buck

If you want to get a head start with the V.42 standard, you have, at the time of this writing, only two choices: You can buy the Hayes V-series Smartmodem 2400 V.42, or you can wait a while longer. The Hayes choice delivers a solid, dependable product along with the expertise and support of an industry leader. You'll pay top dollar (\$899), though, and you'll forfeit MNP-5 compatibility.

The Telcor 2496MA also sports a hefty price tag (\$895), but its features and performance justify its cost: a menu interface, MNP-5 compatibility, advanced security features, blazing proprietary transfers, lots of storage space, and a three-year warranty. We recommend the Telcor 2496MA, especially if you plan to connect two sites with identical models. A Telcor modem at both ends ensures top performance and total security. With just one unit, you lose some of the perks that make the Telcor modem stand out, including the faster transfers and some of the security safeguards.

The Fastcomm FDX 2448 fills out the



Concord Data Systems

feature table nicely, but the E-Tech Bulletin E2400M offers solid performance and all the basic features at an attractive price of just \$395. It outperformed many of the modems costing \$200 to \$300 more. You won't get some of the advanced features, such as password protection, but you will get a solid MNP performer at a reasonable price. ■

BIBLIOGRAPHY

Bingham, John A. C. *The Theory and Practice of Modem Design*. New York: John Wiley & Sons, 1988.

Steve Apiki and Stanford Diehl are testing editors for the BYTE Lab. They can be reached on BIX as "apiki" and "sdiehl."

Faster computers sooner... from **FORTRON**.



NetSet™ 286
12, 16, 20 MHz

NetSet™ 325, 333 DeskTop or Power

Desktop 286 or 386
12, 16, 20 MHz

As fast as products are designed, that's about how fast you can get them from Fortron. In early 1987 we were one of the first to ship an Intel 386™ based personal computer.

Now we're ready to dazzle you with speed again: the NetSet™ 325 and NetSet™ 333 personal computers, based on Intel 386™ 25 MHz and 33 MHz microprocessors. Designed for optimum performance of CAD/CAM, UNIX, XENIX, and network server applications.

Like all our other personal computers, these come with **one full year of service, free, at your site (USA)**. We're that sure of the reliability. And because we manufacture the computers ourselves, right here in California, you know exactly who to call with any technical questions; and if they do need service, we can fix them fast. **Speed, service, and savings. That's Fortron.**

BASIC SYSTEM PRICES START AT:

NetSet 286-12	386-16	386-20 Plus	NetSet 386-325	NetSet 386-333
\$995	\$1950	\$2450	\$3550	\$4950
512K	2MB	1MB	1MB	1MB

To Order Call Toll Free
1-800-821-9771

In CA 415-373-1008

Leasing Program Available
International Distributors Wanted

*386™ is a trademark of Intel Corp.
NetSet is a trademark of Fortron/Source Corp.

FORTRON

Fortron/Source Corp.
6818-G Patterson Pass Road
Livermore, CA 94550
Tel: 415-373-1008
FAX: 415-373-1168 TELEX: 559291

- Please have a sales representative call me.
- Please send me more information.
- 1. I am most interested in
 - A. 286-based systems
 - B. 386-based systems
- 2. I am a
 - A. End User
 - B. VAR
 - C. Corporate Purchaser
 - D. DP/MIS.

Name _____
Title _____
Company _____
Address _____
City _____
State _____
Zip _____
Phone No. _____

6/89

It's time to get a new, better linker. . .

.RTLink™

\$195.00

"The more I used .RTLink, the more I *USED* it...."

a sure sign that a product actually fits one of my programming needs. It significantly improved my productivity...."

Steve Steiner, Data Based Advisor February, 1989

UNIQUE FEATURES:

- **Advanced Overlays** - supports advanced overlay management in ALL languages, even Turbo C, and, for the first time, QuickBASIC. Features multiple overlay areas, nested overlay areas, internal and external overlays, and reloading of overlays on function return. (see 'Other Features:' below)
- **Run Time Libraries (.RTLs)** - .RTLs are optional, easily-created files that can be used to manipulate link speeds, and significantly REDUCE .EXE SIZE. Generally, .RTLs are files that contain common code which is repeated in groups of .EXE files. These files can dynamically link to .EXEs at load time. They reduce the repetitive storage of common code. This results in smaller .EXEs and reduces disk space requirements on shipping media, target and development machines, and reduces the amount of time required to modem updates to remote locations. Production-version RTLs usually contain commonly used language-library code and/or utility code. However...
- **Faster Linking** - ...during development, RTLs can be used to store pre-linked modules. This allows programmers to set aside much of the code that is not being modified, thereby significantly enhancing link speeds. In straight links, RTLink is faster than your current overlay linker. However, RTLink is even faster when RTLs are used as a productivity tool during the development and testing phase. All of the code within an .RTL is pre-linked. Therefore, you can place stable code into an .RTL to eliminate the need to relink it during development. This use of .RTLs can result in lightning fast linking without affecting program testing.
- **Profiling** - provides highly-detailed performance statistics about your program without code modification. Timing sequences are adjustable to thousandths of a second. Source code is provided for the read/analysis utility which allows customized statistics reporting.
- **LIBLIST** - cross-references .OBJ and .LIB files. Illustrates interrelationships and dependencies between modules. Provides much more detailed information than utilities such as LIB.

"The only significant advancement in linking technology in years"

RTLink is a feature-rich overlay linker with unique capabilities and functions which are not available in any other linker, or even attainable at the same high degree of performance in another product.

You can **quickly begin using RTLink** just as you would your current linker, because RTLink supports common link-input formats. However, unlike other linkers, .RTLink provides other easy-to-learn features which can dramatically increase your productivity and your programs performance

"I am very impressed with the product and the people at Pocket Soft, Inc. The product does what it claims to do and the people know their stuff."

Don Powells,
Nantucket Corporation

OTHER FEATURES:

- Multiple Overlays (32,767)
- Nested Overlays (32,767 deep)
- External Overlays
- Internal Overlays
- Maps files
- On-line help
- Quick-start files (ARFs on disk)
- Excellent documentation
- Free tech support
- Easy to use
- Easy to learn
- No performance degradation
- No source code changes
- No royalties
- No risk (30 day refund policy)

WORKS WITH:*

- Microsoft® C™
 - Turbo C®
 - Clipper™
 - MASM™
 - QuickBASIC™
 - BASIC
 - COBOL
 - FORTRAN
 - Clarion™
 - Quicksilver™
- *And most other DOS Compilers which produce .OBJ files.

Order yours today! \$195.00

Visa, Master Card or C.O.D

Call: (713) 460-5600

FAX: (713) 460-2651

Pocket Soft, Inc. 7676 Hillmont, #195 Houston, TX 77040

Trademarks: All Pocket Soft products are trademarks of Pocket Soft, Inc. Other brand and product names are trademarks of their respective holders. © 1989 Pocket Soft Inc.



Big Mac Power in a Small Mac Box

What do you get when
you cross a Mac IIx
with a Mac SE?
The Mac SE/30

Tom Thompson

Look inside Apple's newest Macintosh, the Mac SE/30, and you'll see hardware that looks like something out of a Mac IIx: a Motorola 68030 CPU and 68882 FPU clocked at 15.67 MHz, the Apple Sound Chip (ASC), and 256K bytes of single in-line memory module-mounted ROM. Like the members of the Mac II family, the Mac SE/30 can hold up to 8 megabytes of RAM using 1-megabit-density SIMMs. Yet Apple stuffed all this into the housing of what it calls its "compact" family of computers, which includes the Mac Plus and the Mac SE. Like the Mac SE, the Mac SE/30 still has one slot, but the connector and form factor for the plug-in boards have changed. (For more information, see the First Impression of the Mac SE/30, "The Mac SE Takes Off" by Nick Baran, February BYTE.)

I use a Mac II with a SuperMac 19-inch monitor for my work. The Mac II and an IBM PC AT both sprawl over my desk, leaving room for little else. But I'm not about to give up the Mac II's computing power. So I looked forward to seeing if the small-footprint Mac SE/30 could deliver the performance of a Mac II.

Checking It Out

The Mac SE/30 that I reviewed was fully configured with an 80-megabyte hard disk drive and 4 megabytes of RAM. As is typical of the Mac design, system setup



was simple—plug and play. It took several minutes to hook up the power cord, keyboard, and mouse. Formatting the hard disk and installing the version 6.0.3 System software took a bit longer.

I next checked the machine's networking capability. There are two reasons for this. First, computers today usually don't operate in isolation; they share resources and data on a network. Second, the BYTE Lab's test suite is about 8 megabytes in size. It's far easier to have the AppleShare network hike the test suite from the file server to the review machine than it is to move that many files by hand using floppy disks.

I initially configured the Mac SE/30

to operate as a file server using AppleShare 2.0. I encountered no problems with the installation, and file transfers showed a lot more zip while the Mac SE/30 was in service.

After a day's testing, I reconfigured the Mac SE/30 as an AppleShare workstation and copied the benchmark test suite to its hard disk. The benchmark results show that although it looks like a Mac SE, the SE/30's performance is on a par with that of the Mac II family. On many of the tests, the Mac SE/30 does as well as a Mac IIx, and in some instances, it outperforms it. Compared with a Mac SE, the SE/30 is about two to five times

continued

Important**UNIX will catch on**

Since end of 1988 you don't need star wiring for multi-terminal systems any more. Instead, all those terminals can be connected to a single twin-conductor telephone wire. Neither the terminals nor the computer need be prepared for the bus system - and it won't cost any more than the familiar cabling. This eliminates the main disadvantage of multi-terminal systems as compared with networks. Ask for "Terminal Bus" information.

Terminals/printer up to 3/4 mile away

Electrically isolated line drivers let you set up terminals or printers at distant locations.

22boost, Centronics, 1 pair, 1kV iso.
84boost, RS232, 1 pair, 1kV isolated

Mains filters won't do it all

When computers mysteriously crash, or suffer from lightning discharges, the damage usually arrives along the data lines. Now, opto-isolators that will stand up to 50kV can help you: just interpose them between the computer and its peripherals.

22boost, Centronics, 1kV
66iso, RS422, 500V
88iso, RS232, 1kV
88iso50, RS232, 50kV

Portable Data Buffers

Instrument readings, drilling templates, programs - you can transport all kinds of data in a small, battery-powered buffer.

22b032, Centronics, 32K
22b128, Centronics, 128K
88b032, RS232, 32K
88b128, RS232, 128K

Computers up to 95% faster

Your computer is forced to run with the brakes on because standard printer and plotter buffers are far too small. A buffered data cable will accelerate your computer by up to 95%.

Parallel for PCs:

22i064, 64K
22i256, 256K
22i1024, 1024K

RS232, individually selectable In/Out par. am.
88i28, 128K
88512, 512K

**The ideal T-switch?**

It's so small, it fits into a printer plug - and, naturally, needs no plug of its own. But it will automatically switch a printer between two computers. And it sells so well that just a few lines of advertising are sufficient.

22imca2, 2 PCs to 1 printer

The comprehensive interface program

20mA Atari C64/128 Centr. IBMPC IBMB488 RS232 RS422 RS423 RS485		20mA Atari C64/128 Centr. IBMPC IBMB488 RS232 RS422 RS423 RS485
--	--	--

New catalogue
since Dec, 1st, 88

**wiesemann
& theis gmbh**
THE INTERFACE PEOPLE



Winchenbachstr. 3-5 5600 Wuppertal 2
West-Germany
Telefon: (202) 50 50 77
Telefax: (202) 51 10 50
Telex: 859 16 56 wwd

Austria: Basic 0222-950542 * Belgium: Brother 02-4674211, Info Unifers 03-2323247 *
Denmark: Jatec 06-479139 * England: Meedmore 051-5212202 * France: Neol 88-623752 * Mexico: Sysper Puebla 489236 *
Netherlands: Cat&Korsch 010-4507696 *
Switzerland: Weber 01-9302003 * Singapore: Overseas Trade 2726077 * Distributors wanted!

Mac SE/30**Company**

Apple Computer, Inc.
20525 Mariani Ave.
Cupertino, CA 95014
(408) 996-1010

Components

Processor: 15.67-MHz 68030; 68882
FPU (standard)

Memory: 1 megabyte, expandable to 8 megabytes

Mass storage: 1.44-megabyte 3½-inch floppy disk drive that reads and writes several different machine formats; 40- or 80-megabyte internal SCSI hard disk drive

Display: Built-in 9-inch diagonal black-and-white monitor; displays 512 by 342 pixels

Keyboard: 81-key standard keyboard with keypad (\$129); 105-key extended keyboard with cursor and function keys (\$229)

I/O interfaces: Two RS-232C/RS-422 serial ports with mini-DIN-8 connectors; two custom Apple Desktop Bus ports for keyboard and mouse; SCSI interface with DB-25 connector; stereo sound port; external floppy disk drive connector

Size

13½ × 9½ × 11 inches; 21½ pounds

Software

System 6.0.3/Finder 6.1; system installer utility; hard disk backup and repair utilities; font/desk accessory; printer drivers; HyperCard 1.2.1

Documentation

Owner's guide; system, utilities, and HyperCard user's guides

Price

Macintosh SE/30: \$4369
Macintosh SE/30 with 40-megabyte hard disk drive: \$4869
Macintosh SE/30 with 80-megabyte hard disk drive and 4 megabytes of RAM: \$6569
System as reviewed: \$6798

Inquiry 861.

faster. It especially shines in the computationally intensive scientific/engineering tests, where the built-in FPU helps with the number crunching.

Putting It to Work

My next text was to substitute the Mac SE/30 for the Mac II in my day-to-day work. I moved about 30 megabytes of files from the Mac II to the file server. Next, I set up the Mac SE/30 on top of the Mac II. (To give you an idea of the size

difference between the machines, I placed an external Rodime 140 Plus hard disk drive—built to fit under a compact Macintosh—next to the SE/30 on top of the Mac II, and the Mac II was still easily several inches deeper.) I then copied my files from the server to the Mac SE/30 and went to work.

My usual INITs, such as MasterJuggler, SFScroll, Moire, and Vaccine, installed properly. The TMON 2.8.2 debugger (a patched version that works with the 68030 processor) and THINK C 3.0p4 development software operated flawlessly. I had no trouble editing work using MindWrite 2.1, or connecting to BIX with Red Ryder 10.3. Suitcase II 1.2.2 also worked without a hitch. The one application that didn't was Adobe's Illustrator 88 version 1.6: It threw me into the TMON debugger with a bus error. A beta version of Connectix's Virtual, an INIT that provides 8 megabytes of virtual memory, functioned reliably and let me keep six large applications on call under MultiFinder as I worked.

I was impressed with the Mac SE/30's speed. Some of it is perceived, because the Mac SE/30 has a smaller screen to update, and some of it is due to the processing edge of the 68030. Work under MultiFinder was smooth and responsive, and it was nice to use the background printing facility without causing the machine to seize up.

Except for the small 9-inch black-and-white display, many of the Mac SE/30's characteristics are identical to those of a Mac II. The monitor's cdev, used to set the pixel depth on the Mac II, is operational, although your only choices are black and white. The SysEnviron() trap, used by an application to query the Mac operating system for the machine's characteristics, shows that the Mac SE/30 has Color QuickDraw. Most color applications run on the Mac SE/30, but the colors in a picture map to either black or white, producing posterized images.

I was surprised to find that I didn't miss the Mac II's big screen, although a lot of that has to do with an improvement in third-party software: ALSoft's MasterJuggler let me transfer quickly between applications under MultiFinder while keeping the screen uncluttered. MasterJuggler does this by first providing a pop-up menu of active applications that's invoked at any time with a key combination and mouse-click. As you move among the applications, MasterJuggler hides all the windows except those owned by the foreground application. Thus, what's on the screen belongs

continued



Mac SE/30

Mac SE/30 **17.0***

APPLICATION-LEVEL PERFORMANCE

WORD PROCESSING

MacWrite	Medium/Large
Load	:03/:05
MultiWord word count	:04/:26
Search/replace	:37/4:06
End of document	:01/:02
Merge small	:07/:08
Store	:06/:23
Spelling check	:45/5:59

Microsoft Word 4.0

Cursor down	1:21
Search and replace	:41
Store	:12

Aldus PageMaker 1.0a

Load document	:06
Change/bold	:22
Align right	:20
Cut 10 pages	:16
Place graphic	:05
Print to file	:38

Index: 2.68

SPREADSHEET

Microsoft Excel 2.0

Fill right	:08
Undo fill	4:33
Recalc	:02
Load rlarge3	:12
Recalc rlarge3	:02

Index: 3.53

DATABASE

dBASE III+ 1.1

Copy	:18
Index	:05
List	1:15
Append	:08
Delete	:01
Pack	:04
Count	:02
Sort	:15

Index: 2.99

SCIENTIFIC/ENGINEERING

MiniCAD

Load	:07
Hide and shade	2:29
Redraw	1:51

STATA 1.5

Regression	:53
Correlation	1:07

Index: 5.23

COMPILERS

Microsoft C 5.0

XLisp compile	:50
---------------	-----

Turbo Pascal 4.0

Pascal S compile	:06
------------------	-----

Index: 2.60

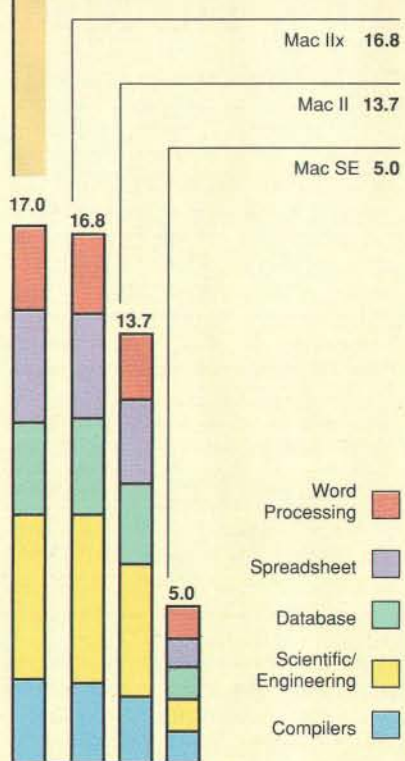

All times are in minutes:seconds. Indexes show relative performance; for all indexes, a Mac SE = 1.

* Cumulative application index. Graphs are based on indexes and show relative performance.

LOW-LEVEL PERFORMANCE¹

Mac SE/30

CPU

Matrix	16.14
String Move	
Byte-wide	81.60
Word-wide	42.10
Longword-wide	22.90
Sieve	31.38
Sort	29.67

Index: 4.61

FLOATING POINT²

Math	149.10
Error	
Sine(x)	73.67
Error	
e^x	98.34
Error	

Index: 1.16

DISK I/O

SubFinder Seek	
SCSI	
1 block	14.22
32 blocks	26.68
Floppy	
1 block	63.73
32 blocks	309.38

File I/O (SCSI)³	
Seek	0.11
Read	0.01
Write	0.01

1-megabyte (SCSI)	
Write	4.28
Read	4.80

Index: 3.01

VIDEO

Text	
Textedit	5.52
Drawstring	2.36
Graphics⁴	
Slow Mac	44.60
QuickDraw	0.31

Index: 2.33

CONVENTIONAL BENCHMARKS

LINPACK	232
Double LINPACK	241
Dhrystone (Dhry/sec) ⁵	3754

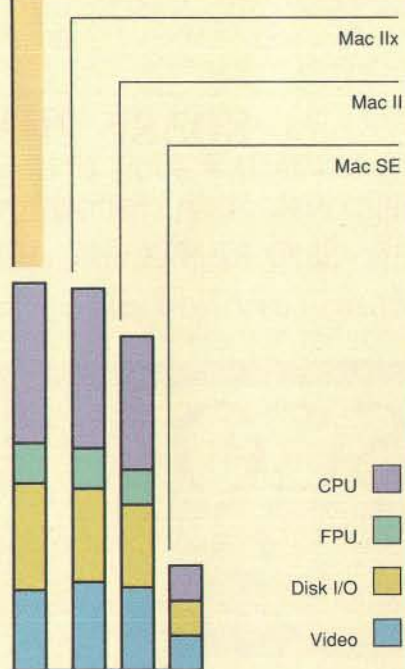

N/A=Not applicable.

¹ All times are in seconds. Figures were generated using the 68000 version of Small-C. Figures for the Mac II use 68020-specific instructions for the LINPACK and Double LINPACK tests only.

² The Floating Point benchmarks use the SANE library.

³ Read and write times for File I/O are in seconds per 64K bytes.

⁴ The Slow test uses code written in Small-C to perform the circle draw and fill. The QuickDraw version uses QuickDraw commands to draw and fill the circle.

⁵ For the Dhrystone test only, higher numbers mean faster performance.

The Mac Does DOS

When you work in an office with a medley of different computers, sooner or later you're going to get asked The Question: "Say, I've got these Excel/PageMaker files on a PC disk. Can you take a look at them and print them out for me?" I get this request a lot, since the IBM PC AT that I use is linked to the Mac II by a serial cable, allowing me to transfer files between the two.

However, the Mac SE/30, like the Mac Ix, has a new floppy disk high-density (FDHD) drive that lets you read and write to 3½-inch 800K-byte Apple II ProDOS or 1.44-megabyte PC-formatted floppy disks. This new drive has been dubbed the SuperDrive.

While I was doing this review, someone asked me to print out some PC Excel

files that were on 3½-inch floppy disks. I launched the Apple File Exchange application and popped the disk into the internal drive slot. I selected the desired files and had the AFE move them to the hard disk drive while performing the default translation. The Mac version of Excel had no difficulty reading the files, and the results came off the laser printer in a matter of minutes.

The Mac SE/30's ability to read and write foreign disk formats is good. If you're on a limited budget, the Mac SE/30 and Mac Ix offer the ability to read the occasional PC disk that users might have to deal with. Mac SE and Mac II owners can upgrade their 800K-byte drives to FDHD SuperDrives for \$599.

only to the application you're working with, and it gives you access to the drives or file server shown on the Mac Desktop.

After its performance, the Mac SE/30's best feature is its price. The top-of-the-line Mac SE/30 reviewed here with an extended keyboard (\$229) costs \$6798. A similarly equipped Mac Ix costs \$8098—without a monitor or video display board. Adding the cost of an Apple monochrome monitor and standard 16-color video board pushes the Mac Ix's price to \$8996, making the price difference between the two systems

a whopping \$2198. If you need color or a large screen later on, the 030 Direct Slot offers you the option of buying a color board from third-party vendors.

If you own a Mac SE, don't despair—Apple hasn't forgotten you. For \$1699, you can swap a motherboard to upgrade your Mac SE to a Mac SE/30. It's not cheap, but it's much better than being stranded, as a lot of Mac Plus owners are.

The Bad and the Good

My one complaint about the Mac SE/30 is that it can't run A/UX, Apple's version

of Unix. Apple doesn't support A/UX on the Mac SE/30 at this time because it doesn't have to an 030 Direct Slot board that would provide network connections for both AppleTalk and Ethernet, something a typical Unix user demands. I hope something is done about this, because the Mac SE/30 seems ready-made as a reasonably priced Unix workstation with decent processing power.

The Mac SE/30 is a nice technical achievement. In terms of size and performance, it can best be characterized as a luggable Mac Ix, and the SuperDrive gives it the ability to read and write PC floppy disks (see the text box "The Mac Does DOS" at left). The Mac SE/30 is true to the original concept of the Mac, down to the whisper-quiet cooling fan and small desktop footprint, yet it incorporates the latest advances in technology. It also brings the architecture of the compact Mac family closely into line with that of the Mac II family by providing an FPU, the same amount of RAM, the same ROMs, and the same sound chip. This should simplify Mac software development, since it brings to a halt what was becoming a bewildering array of different internal hardware.

I'm impressed with the Mac SE/30's processing power—and I'm used to working with a Mac II. I do miss the color, though. If you need the power of a Mac Ix without color or a large screen, give the Mac SE/30 a serious look. ■

Tom Thompson is a BYTE senior technical editor at large. He can be reached on BIX as "tom_thompson."

80386 20MHz XENIX computer COMPLETE
with 40MB <28ms FH hard drive, 1.2MB floppy, 2 serial / 2 parallel ports,
high resolution monochrome monitor with adapter, 101 enhanced keyboard,
386 SCO XENIX and a TWO YEAR WARRANTY now only **2,995.**
Many hardware and software options available.

SCO
TM



**AUTHORIZED
RESELLER**

TRC TECHNOLOGY RESOURCE CENTER

In the US call **800/433-4904**
In California **213/937-8822**
In the United Kingdom **0800-89 1121**
FAX: **213/937-9034**
TELEX: **159211426 TRC UT**

**The Right Answer:
Unplug the Old,
Plug In The New.**



MultiModemV32™ Full Duplex Modem **Both 9600/4800 and 2400/1200/300 bits per second**

Until today, your choices in V.32 9600 bps full duplex modems have been limited. They've been oversized and overpriced, and they couldn't even communicate with 2400 & 1200 bps modems.

Well, that's no longer the case! Multi-Tech's new **MultiModemV32** breaks through those barriers and more.

The **MultiModemV32** gives you 9600 bps full duplex operation with 4800 bps fallback, over both dial-up and leased lines, just like a CCITT V.32 compatible modem should.

However, the most remarkable thing about the **MultiModemV32** is its ability to perform automatic speed detection and switching between 9600, 4800, 2400, 1200 and 300 bps. This allows the modem to automatically match on-line speeds with other V.32, V.22bis and 212A compatible modems.

But that's not all.

The **MultiModemV32** incorporates MNP® Class 3 & 4 Error Correction and Class 5 Data

Compression with Speed Conversion. This gives you error-free communications, with throughputs well in excess of 9600 bps. Add to that a full "AT" command set, auto-dial/auto-answer, and a memory for phone numbers and option setting, and you get a modem with true upward and downward compatibility, that can satisfy most any application*, at a most affordable price.

Why not unplug your older, slower modems? Plug in the new **MultiModemV32**.

All things considered, the **MultiModemV32** is clearly the Right Answer.

Call us toll-free at **1-800-328-9717** for more Right Answers.

MultiTech®
Systems

The right answer every time.

Multi-Tech Systems, Inc.
2205 Woodale Drive
Mounds View, Minnesota 55112 U.S.A.
(612) 785-3500 FAX (612) 785-9874
International Telex 4998372 MLTTC
International FAX (612) 375-9460

* We didn't forget the central sites! Call us for info on our Model MT932ER rack-mounted modems.

MNP is a registered trademark of Microcom, Inc.

When you want the very best!

Be a **Genius**

Geni Scan GS-4000

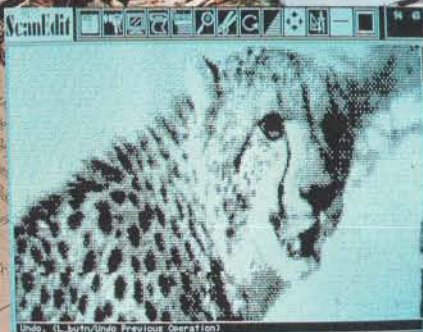

Includes:

- Scanner & Controller
- Genius ScanEdit II
- Dr. Genius Software
- Also available with FrontPage Publisher OCR Software

The **GeniScan GS-4000** hand scanner, with a read width of 105mm, allows you to scan images and documents into files with no distortion. Resolution is switch selectable 100/200/300/400 DPI. New **ScanEdit II** provides extensive printer support, multi window scanning, transparent overlapping, and a merge function which allows you to scan images as large as letter size. Generates TIF, IMG, PCX, MSP, CUT, and OCR formats.

Genius Tablet GT-1212A



includes:

- Genius Tablet 12" x 12"
- 4 Button Cursor
- AutoCAD Template
- Genius Menu Maker
- Dr. Genius Software

The GT-1212A is designed for today's CAD and Paint software for design engineers, architects, and draftsmen.

Genius Dyna Mouse GM-6000



includes:

- GM-6000 Mouse
- Mouse Pad
- Mouse Pocket
- Genius Menu Maker
- Dr. Genius Software
- 9-25 Pin Adapter

The **GM-6000** High Resolution Dyna Mouse has a dynamic resolution of 350-1050 DPI and X-Y locking, as well as a 2 button - 3 button mode switch. The only mouse that supports COM1, 2, 3, 4! **Dr. Genius** is an advanced version of Dr. Halo, which provides scanner interface, and high resolution printer support.

New 2 button mouse

GM-S2: PS/2 Mouse (mouse port)

GM-U2: Serial and PS/2 Mouse

Accessories and software included.

"...it is hard to imagine a better mouse package."

Computer Shopper, Feb. 1989

"Sturdy Construction and Dynamic Resolution are strong points..."

PC Magazine, Feb. 1989

DEALERS call for special Promotion Package!

Coming Soon!

Geni Scan GS-P3

Full Page Scanner with 300 DPI resolution



CamCAD I



entry level CAD contains all the basic functions needed. Easy to learn and use, even for the first time user.

CamCAD II

is a professional CAD package which is easy to use, yet powerful for your important CAD needs.



The manufacturer you can trust!

KYE International Corp.
12675 Colony St. Chino, CA 91710
TEL: (714) 590-3940
FAX: (714) 590-1231

Kun Ying Enterprise Co. Ltd.
11F No. 116, Sec.2, Nanking Road
Taipei, Taiwan, R.O.C.
TEL: (02) 565-2817 FAX: (02) 511-0873



Dead Heat

Choosing between the Tandon and FiveStar computers means looking beyond performance

John Unger

The Tandon 386/20 and the FiveStar Model 320 have joined a growing number of new PCs featuring 20-MHz 80386 CPUs. Computers in this category usually provide high-speed static RAM (SRAM) and I/O caching. They can use from 8 to 16 megabytes of 32-bit RAM and a 20-MHz 80387 coprocessor, and they can handle run-length-limited (RLL), ESDI, or SCSI hard disk drives and controllers.

This combination of speed and CPU is a good trade-off between cost and power. Processors faster than 20 MHz need more expensive components and more sophisticated designs to solve problems like FCC compliance and fast memory access. Besides, a 20-MHz 80386 PC can handle even the most demanding tasks and can run either OS/2 or Unix.

Tandon stands out from the crowd with an integrated system that accommodates an optional 30-megabyte Data Pac removable hard disk drive. The FiveStar Model 320's selling point is a low price tag for a solid system made up of proven, industry-standard hardware that allows a lot of flexibility for customization.

The Tandon 386/20 Model 40 sells for \$5999 with 1 megabyte of RAM, a 64K-byte SRAM cache, a 1.2-megabyte 5 1/4-



inch floppy disk drive, and a 40-megabyte 28-millisecond Seagate hard disk drive (but no video adapter or monitor). A similarly equipped FiveStar Model 320 costs \$2495.

The Tandon 386/20 that I reviewed was the Model 110DP, which has a 110-megabyte 28-ms RLL Seagate hard disk drive and a Tandon 30-megabyte Data Pac. The reviewed system also had 2 megabytes of RAM and a VGA adapter and analog monitor. The price of this loaded system is \$10,479. FiveStar's review machine had an optional 80-megabyte hard disk drive, 2 megabytes of RAM, a 1.44-megabyte 3 1/2-inch floppy disk drive, and a VGA display adapter and multisync monitor. Configured like this, the FiveStar costs \$5325.

Subtle Distinctions

The overall size, shape, layout, and hardware components of the Tandon and

FiveStar are similar. Each computer has eight expansion slots, six of which are designed for 16-bit, AT-compatible cards. The Tandon's remaining two slots are for 8-bit PC-compatible cards. The two other FiveStar slots include an 8-bit slot and a proprietary 32-bit slot for memory expansion. The Tandon uses separate disk controllers for its floppy and hard disk drives, allowing you to choose either modified frequency modulation (MFM), RLL, or ESDI hard disk controllers. But this means you lose a slot to the hard disk drive. After adding video adapter and serial/parallel port cards in the two 8-bit slots, you have only four 16-bit slots free in the Tandon.

The FiveStar uses a floppy/hard disk drive controller card, which, when combined with a serial/parallel card and a video adapter, also gives you four free 16-bit slots, plus the 32-bit proprietary

continued

The Tandon 386/20 (left) and the FiveStar Model 320.

Tandon 386/20

Company

Tandon Corp.
405 Science Dr.
Moorpark, CA 93021
(805) 523-0340

Components

Processor: Intel 32-bit 80386 running at 20 MHz with zero wait states, switchable to 8 MHz; socket for optional 20-MHz 80387 math coprocessor

Memory: 1 megabyte of 80-ns DRAM, expandable to up to 8 megabytes on system board using optional 1-megabyte SIMM modules; 64K bytes of static RAM cache; AMI ROM BIOS 1.01

Mass storage: One 1.2-megabyte 5¼-inch floppy disk drive

Display: VGA card and analog color monitor

Keyboard: 101 full-size keys with 12 function keys; separate editing keys and numeric keypad

I/O interfaces: One RS-232C serial port with DB-9 male connectors; parallel printer port with DB-25 female connector; eight (six 16-bit and two 8-bit) expansion slots

Size

6¾ × 21¼ × 16½ inches; 40 pounds

Software

Microsoft MS-DOS 3.30 and custom utilities; Microsoft GWBASIC 3.22; Microsoft Windows/386; LIM/EMS 4.0 memory support software

Documentation

Operation and installation guide; MS-DOS, Windows, and GWBASIC documentation

Price

Model 40, with 1 megabyte of RAM, 64K-byte SRAM cache, 1.2-megabyte 5¼-inch floppy disk drive, and 40-megabyte hard disk drive: \$5999

System as reviewed (Model 110DP), with 1.2-megabyte 5¼-inch floppy disk drive, 2 megabytes of RAM, 64K-byte SRAM cache, 110-megabyte hard disk drive, Tandon 30-megabyte Data Pac, and VGA color adapter and display (80387 not included): \$10,479

Inquiry 864.

slot. The serial/parallel card on the FiveStar gives you two serial ports.

You can upgrade the memory on either system to 8 megabytes by adding 1-megabyte single in-line memory modules on the motherboard. You can also use 256K-byte SIMMs on the motherboard to obtain a total of 2 megabytes of RAM. For

FiveStar Model 320

Company

FiveStar Computers
1621 West Crosby Rd.
Carrollton, TX 75006
(800) 752-5555

Components

Processor: Intel 32-bit 80386 running at 20 MHz with zero wait states, switchable to 8 MHz; socket for optional 20-MHz 80387 math coprocessor

Memory: 1 megabyte of 80-ns DRAM, expandable to up to 8 megabytes on system board using optional 1-megabyte SIMM modules; 64K bytes of 35-ns static RAM cache; AMI ROM BIOS

Mass storage: One 1.2-megabyte 5¼-inch floppy disk drive

Display: VGA card and analog color monitor

Keyboard: 101 full-size keys with 12 function keys; separate editing keys and numeric keypad

I/O interfaces: Two RS-232C serial ports, one with DB-9 male connector and one with DB-25 male connector; parallel printer port with DB-25 female connector; eight expansion slots (six 16-bit, one 8-bit, and one 32-bit proprietary memory-expansion connector)

Size

6½ × 21½ × 16½ inches; 39 pounds

Software

None

Documentation

User's manual

Price

System with 1.2-megabyte 5¼-inch floppy disk drive, 1 megabyte of RAM, and 64K-byte SRAM cache: \$2495

System as reviewed, with 1.2-megabyte 5¼-inch floppy disk drive, 1.44-megabyte 3½-inch floppy disk drive, 2 megabytes of RAM, 80-megabyte hard disk drive, 80387 math coprocessor, VGA display adapter, and multisync color display: \$5325

Inquiry 865.

the Tandon 386/20, the motherboard SIMMs are the only way to add 32-bit memory. For the FiveStar Model 320, you could also use the proprietary 32-bit expansion bus for RAM expansion; this option would only be an issue if you had 256K-byte SIMMs in your system and wanted to have the full 8 megabytes of

RAM without replacing them with 1-megabyte SIMMs.

Both of these systems use memory caching, which makes it possible for the processor to run with zero wait states much of the time. The caches use 64K bytes of 35-nanosecond SRAM, but neither computer employs the more sophisticated Intel 82385 cache memory controller in combination with the SRAM, as other 20-MHz 80386-based computers (such as the Dell 310 and Compaq 386/20e) do.

Using a memory cache means that, during normal program execution, approximately 80 percent of the data will be available from the cache at zero wait states. If the processor doesn't find the data it needs in the cache, then it accesses normal RAM at the expense of extra clock cycles. The memory cache increases the system's memory I/O speed by a factor of about two, since main memory access would need two wait states with no cache.

You can switch the CPUs of both computers to run at 8 MHz from the keyboards if you have problems running older, speed-sensitive software. The 8- and 16-bit expansion slots run at a constant clock rate of 8 MHz. The optional 80387 coprocessor runs at 20 MHz.

Both computers use the same ROM BIOS from American Megatrends, Inc. (AMI). The BIOS version used in the Tandon system is dated January 13, 1988, and the version used in the FiveStar is dated September 25, 1988. This chip set provides a full suite of ROM-based system diagnostics and setup routines.

The FiveStar Model 320's motherboard is the popular model MI386-20 made by Mylex. This board has a good reputation. The Tandon motherboard carries the Tandon name. Both motherboards appear well-made and have clean designs with easy access to key components such as the coprocessor and SIMM sockets.

Storage to Go

Both microcomputers have enough space and power supply capacity (190 watts for the Tandon and 200 W for the FiveStar) to accommodate a large number of mass storage devices. Each has two main storage bays; the right bay can hold up to three half-height devices, and the center one can house either two half-height or one full-height hard disk drive. The Tandon 386/20's Data Pac hard disk drive module mounts in the center bay.

The disk drive controller board in my

continued



FiveStar Model 320, Tandon 386/20

APPLICATION-LEVEL PERFORMANCE

FiveStar Model 320 **14.7***

WORD PROCESSING		FiveStar	Tandon	DATABASE		FiveStar	Tandon
XyWrite III+ 3.52		Med./Large	Med./Large	dBASE III+ 1.1			
Load (large)	:13	:14	Copy	1:05	:50		
Word count	:02/:16	:02/:16	Index	:20	:20		
Search/replace	:05/:18	:05/:21	List	1:36	1:54		
End of document	:01/:10	:01/:13	Append	1:50	1:42		
Block move	:09/:09	:09/:09	Delete	:02	:02		
Spelling check	:07/:50	:07/:50	Pack	1:20	1:20		
Microsoft Word 4.0			Count	:17	:17		
Forward delete	:11	:12	Sort	1:20	1:18		
Aldus PageMaker 1.0a							
Load document	:10	:13	Index:	1.49	1.52		
Change/bold	:24	:24	SCIENTIFIC/ENGINEERING				
Align right	:18	:19	FiveStar Tandon				
Cut 10 pages	:16	:17	AutoCAD 2.52				
Place graphic	:04	:04	Load SoftWest	:38	:40		
Print to file	1:51	1:52	Regen SoftWest	:28	:28		
			Load StPauls	:09	:10		
			Regen StPauls	:05	:05		
			Hide/redraw	9:35	9:38		
			Index:	4.31	3.97		
			SPREADSHEET				
			FiveStar Tandon				
			Lotus 1-2-3 2.01				
Block copy	:03	:03	Graphics	:23	:38		
Recalc	:01	:01	ANOVA	:11	:12		
Load Monte Carlo	:16	:16	MathCAD 2.0				
Recalc Monte Carlo	:04	:04	IFS 800 pts.	:13	:13		
Load rlarge3	:04	:04	FFT/IFFT 1024 pts.	:13	:13		
Recalc rlarge3	:01	:01	Index:	2.59	2.41		
Recalc Goal-seek	:03	:03	COMPILERS				
Microsoft Excel 2.0			FiveStar Tandon				
Fill right	:04	:04	Microsoft C 5.0				
Undo fill	1:29	1:29	XLisp compile	3:34	3:51		
Recalc	:01	:01	Turbo Pascal 4.0				
Load rlarge3	:21	:22	Pascal S compile	:05	:05		
Recalc rlarge3	:01	:01	Index:	3.21	3.19		

All times are in minutes:seconds. Indexes show relative performance, for all indexes, an 8-MHz IBM PC AT=1.

LOW-LEVEL PERFORMANCE¹

FiveStar Model 320

CPU		FiveStar	Tandon	DISK I/O		FiveStar	Tandon	VIDEO		FiveStar	Tandon
Matrix		3.48	3.54	Hard Seek²				Text			
String Move				Outer track	3.28	3.30	Mode 0	5.49	7.83		
Byte-wide	31.36	31.36	Inner track	3.29	3.30	Mode 1	5.51	7.83			
Word-wide:			Half platter	10.00	10.00	Mode 2	5.40	7.65			
Odd-bnd.	31.27	31.29	Full platter	14.45	13.32	Mode 3	5.42	7.65			
Even-bnd.	15.67	15.67	Average	7.75	7.48	Mode 7	N/A	N/A			
Doubleword-wide:			DOS Seek				Graphics				
Odd-bnd.	23.47	23.45	1-sector	10.52	12.78	CGA:					
Even-bnd.	7.86	7.85	32-sector	28.30	41.90	Mode 4	1.44	1.56			
Sieve	18.84	18.82	File I/O⁴				Mode 5	1.44	1.57		
Sort	14.39	14.32	Seek	0.11	0.07	Mode 6	1.54	1.63			
			Read	1.05	1.14	EGA:					
Index:	3.31	3.30	Write	0.86	1.01	Mode 13	3.16	3.37			
			1-megabyte				Mode 14	3.41	3.70		
			Write	4.72	5.97	Mode 15	N/A	N/A			
			Read	5.38	6.92	Mode 16	3.41	3.64			
			Index:	1.66	1.49	VGA:					
						Mode 18	3.51	3.82			
						Mode 19	1.54	1.63			
						Hercules	N/A	N/A			
			Index:	7.99	8.02	Index:	2.11	1.71			

N/A=Not applicable.

¹ All times are in seconds. Figures were generated using the 8088/8086 and 80386 versions (1.1) of Small-C.

² The errors for Floating Point indicate the difference between expected and actual values, correct to 10 digits or rounded to 2 digits.

³ Times reported by the Hard Seek and DOS Seek are for multiple seek operations (number of seeks performed currently set to 100).

⁴ Read and write times for File I/O are in seconds per 64K bytes.

⁵ For the Livermore Loops and Dhrystone tests only, higher numbers mean faster performance.

CONVENTIONAL BENCHMARKS

	FiveStar	Tandon
LINPACK	177.19	177.52
Livermore Loops ⁵		
(MFLOPS)	0.16	0.16
Dhrystone (MS C 5.0)		
(Dhry/sec)	5910	5910

Tandon 386/20 **14.0***

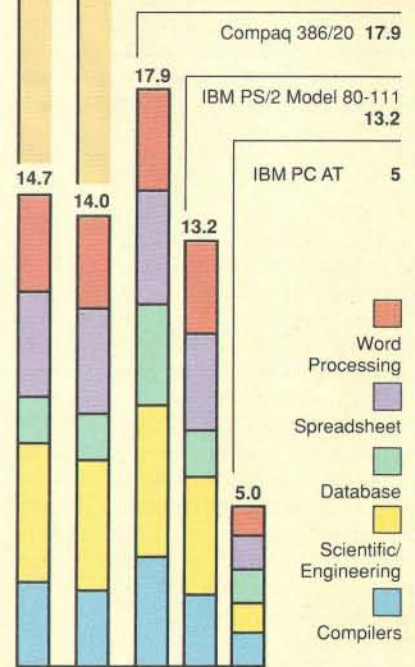

*Cumulative application index. Graphs are based on indexes at left and show relative performance.

FiveStar Model 320 accommodates up to two floppy disk drives and two hard disk drives. Tandon's standard setup includes a floppy disk drive controller for two drives. Adding an optional hard disk drive to the system requires installing its controller in one of the 16-bit expansion slots. This arrangement prevents you from adding an inexpensive MFM hard disk drive to the system without also purchasing a controller.

Tandon offers three hard disk drive controllers as options. One accommodates four MFM fixed hard disk drives; the second allows you to have four RLL fixed hard disk drives; the third has a 128K-byte disk cache and gives you the option of having two 30-megabyte Data Pacs and two RLL hard disk drives or four RLL hard disk drives.

The Tandon Personal Data Pac (\$599) is a removable hard disk drive system that comes packaged either as an external unit to add to any 80286 or 80386 MS-DOS microcomputer or as an integrated internal component of certain Tandon computers, including the 386/20. The Data Pac (\$399) itself is a 30-megabyte 3½-inch hard disk drive mounted in a 2½- by 4¾- by 7-inch plastic case. The hard disk drive is suspended inside the plastic case by specially designed shock absorbers that isolate it from the case. It can withstand shocks up to 250 g's or, as Tandon puts it, a drop of 18 inches onto a hard floor.

Inserting a Data Pac into its drive is much like putting a video cartridge into a VCR; you push the Pac partway into the receptacle until you feel some resistance. Then an internal auto-insertion mechanism takes over and pulls the Pac in the rest of the way and seats the 36-pin electrical connector.

The Data Pac's hard disk drive is designed for ruggedness and speed. Instead of simply parking the four heads on unused portions of the platters when powered down, as most hard disk drives do, the Data Pac incorporates fork-like fingers to lift and lock the heads completely off the disk platters when the drive is turned off. This system ensures against jolts during transport that might move the heads from the "parked" zone onto data sectors.

Two features enhance the Data Pac's performance. First, the special RLL controller has 128K bytes of memory for caching disk I/O, allowing the drive to read data by track rather than sector. Second, the directory information is put onto the platter's middle tracks rather than on the outside. This cuts down the average distance the heads have to move

to find a track after reading the directory's file allocation table.

Face to Face

These two systems are so similar in their specifications that you would not expect to see much difference in their performance—a suspicion borne out by the BYTE benchmark results. Both outperform the IBM PS/2 Model 80-111 by a small margin and fall slightly below the Compaq 386/20. Compared to other 20-MHz 80386 computers that BYTE has recently tested (see the Review Update, "Benchmarks at a Glance," in the December 1988 BYTE), the Tandon and FiveStar machines perform respectably, falling near the middle of the group.

Perhaps more important, these computers feel fast in terms of screen updates, disk I/O, and general computational performance, such as compiling C source code or recalculating spreadsheets. They left no doubt that I was using a couple of hot machines!

Essentials and Extras

Tandon includes a generous collection of software with the 386/20. Not only do you get MS-DOS 3.30 customized for Tandon machines, but you also receive Microsoft Windows/386, GWBASIC 3.22, and a LIM/EMS 4.0 support program, all with full documentation. The operation and installation guide takes the new owner through all the steps necessary to get the Tandon 386/20 up and running. It provides details for adding extra SIMMs and an 80387 coprocessor as well as other system components. Tandon also includes an easy-to-follow pictorial setup guide.

The FiveStar came with a photocopy of a 37-page preliminary user's manual with a table of contents but no index. This manual is adequate for getting the system set up and operating, but it falls short in terms of completeness when compared to the Tandon's documentation. I also received a copy of the Mylex technical reference manual for the motherboard, which was helpful for learning about some of the system's features and technical details. The FiveStar Model 320 does not come with any standard software.

With computers like these two, most software compatibility issues depend on the choice of video adapter and monitor and not on the computer itself. I ran WordPerfect 5.0, Microsoft's Flight Simulator 3.0, Quattro 1.0, Reflex 1.5, and all of Sierra's King Quest series of games on both machines without any problems. Using Borland's Turbo C 2.0

with the Turbo Debugger was a pleasure on such fast hardware.

After-Sale Service

A major difference between the two manufacturers is that Tandon is large and established with a proven track record whereas FiveStar is a relatively small-size newcomer. FiveStar's relative inexperience is shown by a slight mix-up concerning video components for my review computer. The optional XTRON multi-scan monitor that FiveStar sent had a 9-pin EGA connector, and the Paradise VGA Professional video card installed in the computer had an incompatible 15-pin VGA connector.

FiveStar provides a one-year limited warranty on parts and labor, which includes toll-free technical support. For \$99 you can get one year of on-site service with 48-hour turnaround. Tandon offers a simple one-year warranty. In both cases, you are responsible for shipping the damaged hardware back to the manufacturer for warranty repairs.

Perceived Values

Despite the similarities of these two computers, their price tags are surprisingly different. As reviewed, the Tandon 386/20 at \$10,479 costs 30 percent more than a FiveStar Model 320. The Tandon does come with a lot of operating-system and utility software not included with the FiveStar, but not \$5154 worth. The Tandon is overpriced compared to the FiveStar and its other competitors in the 20-MHz 80386 market. Its only unique feature, the removable Data Pac hard disk drive, is available from Tandon as an external add-on for use with any 80286 or 80386 computer. Unless you can find this computer heavily discounted, buy a machine like the FiveStar.

The FiveStar is a bargain compared not only to the Tandon 386/20, but also to most other 20-MHz 80386 computers. The absence of operating-system software and thorough documentation are not much of a deterrent to experienced MS-DOS users interested mainly in performance per dollar. Since you can buy the computer as a bare-bones system with one 1.2-megabyte 5¼-inch floppy disk drive, a 64K-byte SRAM cache, and 1 megabyte of RAM for only \$2495, you can customize the system with components of your choice. ■

John Unger is a geophysicist for the U.S. government and lives in Hamilton, Virginia. He writes graphics software and uses computers to study the earth's crust. You can reach him on BIX as "junger."

Compromise Your Standards And Nobody Else Will Talk To You.



In The Dial-Up World, Connectivity Is Just As Important As Speed.

Just about every V.32 modem ad you read hypes speed. However, it doesn't matter how fast a modem transmits data, if the one at the other end can't receive it.

If you rely on a modem that uses proprietary modulation schemes, handshaking techniques or data compression classes, you've compromised your connectivity.

Which is why you should choose our DataComm 296B. It's fully compliant with V.32 standards. So it can talk to any other real V.32 modem, synchronously or asynchronously, without any tricks, using universally available data compression techniques.

And if you're really looking for throughput, consider this: our DataComm 296B will sustain in excess of 30,000 bps, full duplex, under real world conditions, using real world data and industry standard MNP* Class 5.

But, because bits-per-second are not the only measure of throughput, you should consider our Continuously Adaptive Echo Cancellation feature. It can improve throughput

even further by drastically reducing retransmissions. (If you get it right the first time, your throughput will be higher, and your phone charges lower.)

So if you're really serious, don't compromise your standards. Contact us. Our representatives have a whole lot more to talk about. Like Automatic Dial Back-Up, DataCommonality and a nationwide service organization.

Call 1-800-777-4005, General DataComm, Middlebury, CT 06762-1299. Tel.: (203) 574-1118, Telex: 643357, Fax: (203) 758-8507.



In Data Communications, There's Only One General™

 General DataComm

**FIVE SPEED V.32
ALSO AVAILABLE**

*MNP is a trademark of Microcom, Inc.

Now Providing Full UNIX Support.
Call For Details.

V.32 at 38,400 bps.



MNP® Class 9

Because life is too short
to use a slow modem.

We couldn't make our dial-up modems any more accurate. So we made one twice as fast. And it's available today.

Introducing QX/V.32c, the world's fastest dial-up modem. At 38,400 bps, with full-duplex CCITT V.32 compatibility over dial-up lines. Plus all the added performance and Enhanced Data Compression of MNP® Class 9. There's compatibility with V.22bis, V.22, Bell 212A and Bell 103 included, so that QX/V.32c communicates at optimum levels with modems of all speeds. And it can work in synchronous or asynchronous environments.

Speed and performance are not the only powerful features of the QX/V.32c. Its compact design is equally impressive — 1/3rd the size of most competitive modems. And it comes in a rack mount version, as well.

What will you pay for our breakthrough V.32 modem? About the same as modems with only half the error-free throughput. As you can see from the chart, lower phone bills alone could pay for this upgrade.

9600 bps modem\$6.94

QX/V.32c...\$1.74

Comparable costs of sending identical amounts of data over dial-up lines.

Find out how Microcom brought error-free V.32 to 38,400 bps levels. Call toll-free **800-822-8224** today.



Workstation
Connectivity
Worldwide

500 River Ridge Drive, Norwood, MA 02062 617-551-1000 Telex 710-336-7802 MICROCOM NWD

Worldwide Distribution—International FAX: 617-551-1007 USA FAX: 617-551-1006

Toll-free 800-822-8224

MNP is a registered trademark of Microcom, Inc. QX/V.32c and Enhanced Data Compression are trademarks of Microcom, Inc.



Handy Scanners



These six PC-compatible devices perform best on small scanning jobs

Mark L. Van Name
and Bill Catchings

Hand-held scanners offer an inexpensive way to digitize images. While they aren't as easy to use or as powerful as flatbed scanners, they cost much less than their bigger cousins. This makes them attractive for applications that don't require high-quality images. We examined six PC hand-held scanners (their features are summarized in table 1), and we discovered that there's much to understand about these seemingly simple devices.

Scanner Basics

The scanner itself looks like an overgrown mouse with a 6-foot tail. That cord connects to a half-length interface board that plugs into an 8- or 16-bit PC expansion slot. These boards' use of interrupts, direct-memory-access channels, or I/O addresses might conflict

with other boards in your system; you can usually change their settings if you get a conflict.

The scanners also include driver software that lets you edit, save, and print the scanned image. To scan an original, first you place it on a flat surface. Then, with the software ready to receive an image, you position the scanner at one end of the original, press the activation button, and slowly drag the scanner across the original.

As you move the scanner, you can monitor your progress. All the units we tested except SkyScan have a small view window through which you can see the original. SkyScan, The Complete Hand Scanner/400, the HS-3000, and the GS-2000 Plus also display the image on your monitor as you scan.

The process sounds easier than it is. These scanners are sensitive: It's easy to actually scan an image, but it's difficult to get a good result. Getting a good image is an art, not a science, and the process varies among scanners. You must scan slowly and carefully—if you move too fast or twitch slightly, you can mess up the result. And holding a true course is hard. For example, all the scanners except The Complete Hand Scanner/400 insist that you hold in a button while you scan, and the force of pushing that button on the side of the unit can cause a crooked scan.

To get a good image, you also must consider the scanner's options. All these scanners except Niscan have controls to set different scanning parameters. (Niscan's controls are in software.)

All the scanners offer two basic controls. One lets you adjust the darkness of the final image, determining how dark a point on the original must be before the scanner will read it as black. The other control lets you tell the scanner to read the original either as a black-and-white image (line art) or as one that has meaningful shades of gray (photographs).

continued

Clockwise from top left: Skyworld Technology's SkyScan, Comar Systek's Niscan, KYE International's GS-2000 Plus, DFI's HS-3000, The Complete PC's Complete Hand Scanner/400, and Logitech's ScanMan.

Table 1: Features available on the six hand scanners.

Name	Price	Required memory (K bytes)	Graphics modes supported	Max. dpi (physical)	Other resolutions	Max. scan width (inches)	Max. scan length (inches)	Interface	Unit size (h×w×d) (inches)
The Complete Hand Scanner/400	\$299	640	CGA, EGA, VGA, Herc.	400	200, 300	2.5	14	DMA, IRQ	1¼×3½×4¾
HS-3000	\$329	640	CGA, EGA, VGA, Herc.	200	100, 300, 400	4.13	20	DMA, IRQ (opt.)	1¼×5¼×3½
GS-2000 Plus	\$299	512	CGA, EGA, VGA	200	100, 300, 400	4.1	6	DMA	1¼×5¼×3½
ScanMan	\$339	384	CGA, EGA, MCGA, VGA, Herc.	200	100, 300, 400	4.14	41.5	DMA	1¼×5¼×3½
Niscan	\$299	640	CGA, EGA, VGA, Herc.	200	100	4	11	I/O ports only	1¼×5×6¼
SkyScan	\$349	384	CGA, EGA, VGA, Herc.	200	None	4.16	18	DMA (opt.)	1⅞×5¼×2¾

Notes: CUT=Dr. HALO
.IMG=GEM
.MSP=Windows Paint
.OCR=OCR Systems ReadRight
PCX=PC Paintbrush/Publisher's Paintbrush
PIX=WordStar 2000 Inset format
SSC=SkyScan format
SED=GeniScan ScanEdit format
.TIF=Tag Image File Format
.001=The Complete Fax file format

SkyScan offers only these two options. If you want to capture photos, the others let you choose from three different ways of representing the gray tones. All the scanners except SkyScan also have a third control that lets you choose the scanning resolution. While many claim resolutions of 300 and 400 dots per inch, only The Complete Hand Scanner/400 does true 400-dpi scanning.

Finally, the scanning width is necessarily small. With the exception of The Complete Hand Scanner/400, which has a maximum scan width of about 2½ inches, all the units have roughly a 4-inch wide (10½ cm) scan width. The maximum length of the scanned image varies with the resolution you use and the amount of memory in your PC.

If you want to scan an image that's larger than the scanner's maximum scan width, be prepared for a major struggle. You must scan the original in strips and then use either the scanner's software or a compatible paint program to edit those strips into a single larger image. The good news is that the software included with most of the scanners can save images in more than one file format. The software also typically lets you crop images and edit them in other simple ways, as well as save and print them.

Looking Inside

Before the software can do anything, the scanner must send it an image. The scanner reads the original a line at a time. LEDs shine a red or yellow-green light

onto the original, and a series of sensors in the scanner eventually picks up the reflection of that light off the original.

There are two approaches to capturing that reflection. The most common involves charge-coupled devices (CCDs). All the scanners except SkyScan are CCD units. In a CCD scanner, the original reflects the light to a mirror, which reflects that light onto a second mirror, which then reflects the light through a lens and onto an array of CCD sensors. This convoluted route is about 40 millimeters long and is necessary because the CCD sensors require some optical reduction of the reflected light.

The ScanMan, GS-2000 Plus, and HS-3000 use a basic scanning engine from Omron Electronics. ScanMan has an Omron red-light scanner, while the other two use a yellow-green one. Scanners can't see colors that match that of their LED light source, so a scanner that uses a yellow-green light will perform better with color images.

SkyScan uses contact image sensors (CISes), a newer and more expensive technology. Here, the light reflects from the original directly to the sensors, without any mirrors, giving a short (5 mm) optical path. This shorter path loses less light intensity than the longer one in CCD scanners and should result in a clearer picture.

Regardless of the basic approach, the number of sensor elements, along with the maximum scan width, determines the maximum physical resolution of the

scanner. For example, all the CCD scanners use a 1024-element CCD array. They discard the values of roughly 90 elements on each side of the image, however, because the lens distorts images more on the sides. That leaves over 800 elements (832 for Omron-based scanners, 840 for Niscan) for the image. Therefore, with a scan window of a little over 4 inches, these units have a maximum physical resolution of 200 dpi.

The exception to this is The Complete Hand Scanner/400, which has a true maximum physical resolution of 400 dpi. It uses the same 1024-element CCD array, but with a smaller 2½-inch maximum scan width. It also discards the values of fewer of the sensors on the edges.

In the vertical axis, the maximum physical resolution is determined by how often the scanner's interface board can read the results of the sensor array and be ready for the next line. All these scanners have matching horizontal and vertical resolutions.

Many scanners also offer "effective" resolutions of either 300 or 400 dpi. They simulate the extra horizontal resolution by interpolating between the values of adjacent sensor elements, thereby doubling the number of effective elements. In the vertical axis, they simply double each line.

Image Translation

The sensor elements themselves interpret the reflected light they receive as one of a

LED color	File formats supported	Software
R	.001, .CUT, .IMG, .MSP, .PCX	SmartScan
Y/G	.CUT, .IMG, .MSP, .PCX	Scan, HALO DPE
Y/G	.CUT, .IMG, .MSP, .OCR, .PCX, .SED	ScanEdit, Dr. HALO III
R	.PCX, .TIF	PaintShow Plus, Scan2TIF, Scan2PCX
R	.CUT, .IMG, .PCX, .TIF	GEM Scan
Y/G	.CUT, .IMG, .MSP, .OCR, .PCX, .PIX, .SSC, .TIF	SkyScan

fixed number of gray scales. The sensors in all six scanners can handle 4 bits of gray-scale data for up to 16 gray scales.

Gray scaling is an output technique that produces grays by using dots consisting of different shades of gray. Strictly speaking, none of today's laser printers can print gray scales, because all laser printer dots are the same darkness. Another much-abused term is *halftoning*. A halftoned picture is one whose dots are of different sizes. Again, laser printers can't do halftones, since all laser printer dots are the same size.

But laser printers can use dithering to simulate grays. Dithering represents a dot's gray shade with not one printed dot, but several. It involves a matrix of dots into which you translate each gray value. For example, to simulate 16 gray shades, you might use a 4x4 dithering array. There's one matrix pattern for each possible gray shade. Dithering algorithms also often vary matrix assignments from one dot to the next, to avoid lines or other repetitive patterns in sections of the image that contain many dots with the same gray shade. By using many dots to represent the characteristics of one, dithering sacrifices resolution for the appearance of additional gray shades.

In hand scanners, sensor element values are one of 16 gray scales. The image they represent, however, will be output on a laser printer that can't directly print gray scales. The scanner could just send the gray-scale data to the PC and let the software use dithering to

make the printed image reasonably represent the scanned image; however, sending 4 bits per sensor element would be too much for many PCs. So, all the scanners turn the gray scale of each sensor element into a simple 0 or 1, for white or black.

How each scanner performs this translation varies, but they all use the same basic technique. Scanner vendors call this technique everything from *halftoning* to *hardware dithering*. We prefer the term *image translation* because it's not already fraught with meaning.

Image translation is much like dithering. The scanner reads a sensor element and compares that element's gray value with the next available element in a matrix. Based on that comparison, the scanner sends either a 0 or a 1 for that sensor element.

For example, if the Niscan sensor's gray value is greater than or equal to the value of the comparison matrix element, the scanner sends a 1. Otherwise, the scanner sends a 0. Niscan also varies its lookup matrix between dots so that lines won't appear in the final image. The three different gray-scale translation options mentioned earlier are typically just different matrices that the scanner uses in its image translation.

Now you have black and white dots coming from the scanner, and laser printers can handle those dots. Problems arise, however, when the resolutions of the scanned image and the printer are different. Most of today's laser printers print at 300 dpi. If you use the 300-dpi setting that most of these scanners offer, then the image produced will be the one you see on the printer. When you want to print a 200- or 400-dpi image, however, you must make some hard choices.

If the scanned image's resolution is 400 dpi (or any other resolution greater than 300 dpi), you have two choices. You can print at that resolution, but the printed image will be bigger than the original: Every inch across on the original will take 1½ inches on the printed page. If you want to preserve the size of the original, the software must throw away some of the dots it got from the scanner. Neither option is great. After comparing the printed output of The Complete Hand Scanner/400 with the others, we think 400-dpi scanning is not worth much without a 400-dpi printer.

Similar problems occur when the scanned image's resolution is less than the printer's 300 dpi. Again, you can print exactly the same dots if you're willing to have the printed output a different size than the original. In this case, the

COMPANY INFORMATION

The Complete PC, Inc.
(Complete Hand Scanner/400)
Cottonwood Dr.
Milpitas, CA 95035
(800) 634-5558
Inquiry 856.

DFI, Inc.
(HS-3000)
2544 Port St.
West Sacramento, CA 95691
(916) 373-1234
Inquiry 857.

KYE International Corp.
(GS-2000 Plus)
12675 Colony St.
Chino, CA 91710
(714) 590-3940
Inquiry 858.

Logitech, Inc.
(ScanMan)
6505 Kaiser Dr.
Fremont, CA 94555
(415) 795-8500
Inquiry 859.

Nisca, Inc.
(Niscan)
1919 Old Denton Rd., Suite 104
Carrollton, TX 75006
(800) 245-7226
Inquiry 862.

Skyworld Technology, Ltd.
(SkyScan)
1772 Lark Lane
Sunnyvale, CA 94087
(408) 446-9392
Inquiry 863.

printed version will be smaller than the original, because the 200 dots that represent an inch of the original will take only two-thirds of an inch on the laser printer. If you want the printed image to stay the same size as the original, the output software must add some extra bits to turn those 200 dpi into 300 dpi.

The Products

We tested the scanners with an 8-MHz AT clone, a Hewlett-Packard LaserJet IID, and BYTE's scanning template. Figure 1 shows the template and a laser-printed output of the best scan from each unit. The template is challenging because it contains both black-and-white line art and a photograph.

The Complete Hand Scanner/400. AI-
continued

Figure 1: The BYTE scanner template (a) and the best results we could obtain for each scanner tested. We performed all scans at medium brightness. (b) The Complete Hand Scanner/400 at 300 dpi with spiral dithering. (c) The HS-3000 at 300 dpi with middle-dot translation. (d) The Niscan at 200 dpi with gray spiral. (e) The ScanMan at 300 dpi with small-dot translation. (f) The SkyScan at 200 dpi with halftone setting. Missing is the GS-2000 Plus, which produced only a partial image at its best setting.

though this unit offered the only true 400-dpi resolution of the bunch, we got the best overall printed images with the 300-dpi setting. The line drawings were a touch clearer at 400 dpi, but not enough to compensate for the better photo scan at 300 dpi. This difference is almost certainly because 300 dpi matches the printer's resolution.

The cost of the extra physical resolution is its very small maximum scan width. While the unit includes a utility that lets you patch scans together, that's a job you should avoid.

Of the reviewed scanners, this package had the nicest manual and one of the best installation programs. The software checked the system for possible hardware conflicts and suggested alternate settings where applicable. In addition, its square shape made it one of the easier scanners to drag.

HS-3000. The HS-3000's software is its biggest problem. You can't print from the Scan program that drives the scanner; instead, you must use the included HALO DPE. You can stay in HALO DPE the whole time, but if you scan from it, you can't see the scanned image until you finish.

HALO DPE has one of the worst user interfaces we've seen. It proves that icons alone don't guarantee ease of use. No one would think to look under the scissors icon to load a stored image, for instance. HALO DPE may handle most basic image-editing needs, but it's painful to use.

While the HS-3000 only simulates resolutions greater than 200 dpi, its 300-dpi scans were very good.

GS-2000 Plus. KYE International's scanner proves that all scanning packages that use Omron scanners aren't created equal. Like the HS-3000, it offers simulated resolutions greater than 200 dpi, but its scanning program couldn't handle the entire BYTE template at higher resolutions. It never gave an error, but it always threw away at least



half the image—probably because of its unreasonably small 128K-byte scanned image buffer. KYE International plans to fix this limitation in a future release. The image halves that it did produce at the higher resolutions were attractive.

We also had a devil of a time printing with the scanner software. We gave up and printed with another paint program, which illustrates the value of being able to save images in multiple file formats.

ScanMan. Our final Omron-based



scanned image directly to a file without displaying the image in the process.

Niscan. Niscan doesn't try to simulate a resolution greater than 200 dpi, and that omission is often visible in the printed output. While its 200-dpi images were among the best of the 200-dpi scans we made, the simulated 300-dpi scans from the other packages were better.

Niscan was also the biggest scanner and, as a result, one of the hardest to maneuver. On the other hand, Niscan had the best software environment, in large part because it uses DRI's GEM. It was also nice to be able to control the scanner completely from software and not have to worry about synchronizing hardware and software settings.

SkyScan. Our only CIS scanner was also the only one to offer no resolution options. It did 200 dpi and nothing else. However, its 200-dpi images were nearly on a par with the simulated 300-dpi output of many of the other units.

SkyScan was by far the easiest scanner to drag. Its square shape and large rollers fore and aft of the scanning area (the others have a roller on only one side) made it easy to scan straight. That's fortunate, since it has no viewing window for checking the original as you scan. You can, however, display the image during scanning using the SkyScan program, which also features some of the easiest-to-use printer controls, including options to place the image anywhere on a page and to add descriptive headings.

Which Way to Go?

Price won't help you choose among these scanners, since the units vary by only \$50. Image quality is also a toss-up: At the least, The Complete Hand Scanner/400, the HS-3000, and the ScanMan were all too close to call on their ability to reproduce the photo—and the other packages weren't far behind. The Complete Hand Scanner/400 did have a slight lead in line-drawing reproduction.

When we began working with these scanners, we were underwhelmed. If you must have images approaching photographic reproduction, don't look to hand scanners. Nevertheless, their reasonable (albeit imperfect) printed images should be satisfactory for some applications. We're convinced that any of these scanners can produce an image that would adorn any newsletter. ■

scanner produced a very good simulated 300-dpi picture. Unfortunately, printing that picture was a chore. ScanMan required installing a TSR program, called Catch, before we could print. To try different resolutions, we had to change the

printer settings in both Catch and ScanMan's PaintShow Plus program.

Unlike HALO DPE, PaintShow Plus is a full-blown paint program that's easy to use. You can scan from the program or from either of two utilities that send the

Mark L. Van Name and Bill Catchings are independent computer consultants based in Raleigh, North Carolina. You can reach them on BIX c/o "editors" and as "wbc3," respectively.

Take any 3 books for only \$1⁰⁰ each



when you join BYTE Book Club[®] VALUES UP TO \$139.50

- Your one source for computer books from over 100 different publishers
- the latest and best information in your field
- discounts of up to 40% off publishers' list prices

OS/2 PROGRAMMER'S GUIDE. By E. Iacobucci. 1100 pp., illus., softbound. "Byte" magazine called it "a necessity." This giant reference explains all the basic functions you'll need, with emphasis on such new or different functions as multitasking and memory management.

881300-X Pub. Pr., \$29.95

UNIX UTILITIES. By R.S. Tare. 352 pp., illus., softbound. This practical manual shows how to make the best use of UNIX utilities. It covers more utilities than any other book of its kind and provides numerous examples of real applications.

628/84X Pub. Pr., \$27.95

dBASE POWER: Building and Using Programming Tools. By P.L. Olympia, R. R. Freeland, and R. Wallin. 380 pp., illus., softbound. This practical guide shows the experienced dBASE III or dBASE III PLUS programmer how to use to the fullest such features as RUN and CALL/LOAD, as well as how to write C and assembly language programs that perform dBASE functions for you.

584696-9 Pub. Pr., \$29.95

A PROFESSIONAL'S GUIDE TO SYSTEMS ANALYSIS. By M.E. Modell. 307 pp., illus. Detailed coverage of what you need to know—what questions to ask, how to conduct a cost-benefit analysis, how to document and validate your findings—to design the best systems for your user's needs.

426/325 Pub. Pr., \$34.95

ADVANCED GRAPHICS IN C: Programming and Techniques. By N. Johnson. 430 pp., illus., softbound. Now C programmers can write crisp graphics programs for the IBM-PC using the IBM EGA (Enhanced Graphics Adaptor) or the AT&T Image Capture Board (ICB). Includes GRAPHIQ, a complete C graphics toolkit.

881257-7 Pub. Pr., \$22.95

A COMPREHENSIVE GUIDE TO AI AND EXPERT SYSTEMS: Turbo Pascal Edition. By R.I. Levine, D.E. Drang, and B. Edelson. 256 pp., 99 illus. A must for everyone who wants to understand and utilize artificial intelligence for commercial, military, scientific, or educational applications. It's all in clear, simple language with many illustrations and sample programs.

374/708 Pub. Pr., \$24.95

ADVANCED TURBO C.[®] By H. Schildt. 397 pp., illus., softbound. Complete Turbo C mastery can be yours—from stacks, queues, linked lists and binary trees, to operating system interfacing, porting, debugging, and much more. Fully explains how to get the most from the power and speed of Turbo C.

881280-1 Pub. Pr., \$22.95

ADVANCED 80386 PROGRAMMING TECHNIQUES. By J.L. Turley. 509 pp., illus., softbound. Offering advanced techniques for serious programmers, this hands-on-guide covers advanced memory segmentation, the internal four-level protection hierarchy, multitasking, demand paging, system security, 8086/80186/80286 emulation, and intertask communication.

881342-5 Pub. Pr., \$22.95

THE WAITE GROUP'S MS-DOS BIBLE, Second Ed. By S. Simrin. 522 pp., illus., softbound. Shows you how to start up your system, create and manage files, customize your keyboard, and become proficient in such advanced MS-DOS features as LINK, DEBUG, TSR programming and device drivers.

584702-7 Pub. Pr., \$22.95

EGA/VGA: A Programmer's Reference Guide. By B.D. Kiewer. 269 pp., illus., softbound. All the practical guidelines are right here for learning the ins and outs of the Enhanced Graphics Adaptor—one of the most popular PC add-on boards available—and its PS/2 counterpart, the Video Graphics Array. It's filled with innovative programming techniques . . . tips for working around the bugs in the BIOS . . . and EGA/VGA BIOS calls not available elsewhere.

350/892 Pub. Pr., \$29.95

DATABASE SYSTEM CONCEPTS. By H. F. Korth and A. Silberschatz. 546 pp., illus. From fundamental concepts to advanced problem solving, this book provides a clear understanding of the design and use of database systems. Also demonstrates the best ways to protect data from unauthorized access and malicious or accidental alteration or destruction.

447/527 Pub. Pr., \$44.95

ARTIFICIAL INTELLIGENCE USING C: The C Programmer's Guide to AI Techniques. By H. Schildt. 412 pp., 37 illus., softbound. This hands-on guide shows you how to create your own AI applications and systems using C. After an introductory overview it provides coverage of expert systems, logic, natural language processing, machine learning, pattern recognition, and more, with ready-to-run programs illustrating each topic.

881255-0 Pub. Pr., \$21.95

PROGRAMMING USING THE C LANGUAGE. By R.C. Hutchison and S.B. Just. 519 pp., illus. Whether you want to understand programs in C written by others, or write better C programs of your own, this practical, authoritative book gives you the tools and guidance you need. Coverage includes program organization, sorting algorithms, recursion, linked lists, and more — with many sample programs.

315/418 Pub. Pr., \$29.95

HARD DISK MANAGEMENT with MS-DOS and PC-DOS. By D. Gookin and A. Townsend. 307 pp., illus. Shows you how to make the best use of your hard disk for all types of programs, with an emphasis on organization, data security, and enhancing performance. Easy enough for novices, yet sophisticated enough for power users, it's packed with helpful hints, proven shortcuts, and clear explanations.

583954-7 Pub. Pr., \$27.95

TRICKS OF THE UNIX MASTERS. By R.G. Sage. pp. illus. Many of UNIX's most interesting features have virtually been kept secret from users — until now! This master guide goes beyond the basics to show you the shortcuts, tools, tips, and tricks it could take years to discover on your own.

584637-3 Pub. Pr., \$22.95

SADT: Structured Analysis and Design Technique. By D. Marca and C. McGowan.
402/353 Pub. Pr., \$49.95
(Counts as 2 of your 3 books)

PROGRAMMING WITH TURBO PASCAL. By D. Carroll.
852908-5 Pub. Pr., \$39.95

HIGH-SPEED ANIMATION & SIMULATION FOR MICROCOMPUTERS. By L. Adams.
583855-9 Pub. Pr., \$20.95

PROGRAM TRANSLATION FUNDAMENTALS: Methods and Issues. By P. Callingaert.
584589-X Pub. Pr., \$36.95

HOW TO BE A SUCCESSFUL COMPUTER CONSULTANT. By A. R. Simon.
572/968 Pub. Pr., \$24.95

UNDERSTANDING & USING dBASE III® PLUS. By R. Krumm.
583940-7 Pub. Pr., \$22.95

32-BIT MICROPROCESSORS. Edited by H. J. Mitchell.
425/85X Pub. Pr., \$48.50

8086/8088/80286 ASSEMBLY LANGUAGE, Revised & Expanded. By L.J. Scanlon.
584839-2 Pub. Pr., \$21.95

NETWORKING SOFTWARE. By C. B. Ungaro.
606969-9 Pub. Pr., \$39.95

THE DATABASE EXPERT'S GUIDE TO SQL. By F. Lusardi.
390/061 Pub. Pr., \$39.95

PRINCIPLES OF ARTIFICIAL INTELLIGENCE AND EXPERT SYSTEMS DEVELOPMENT. By D.W. Rolston.
536/147 Pub. Pr., \$44.95

APPLYING TURBO PASCAL LIBRARY UNITS. By N. Shammass.
584791-4 Pub. Pr., \$22.95

DATA STRUCTURES USING PASCAL, 2nd Ed. By A. M. Tenenbaum & M. J. Augenstein.
583738-2 Pub. Pr., \$46.00

MICROCOMPUTER LANS: Network Design and Implementation. By M.F. Hordeski.
584580-6 Pub. Pr., \$28.95

OPERATING SYSTEMS. By M. Milenkovic.
419/205 Pub. Pr., \$42.95

IBM® PS/2® TECHNICAL GUIDE. By C.M. Halliday & J.A. Shields.
584831-7 Pub. Pr., \$24.95

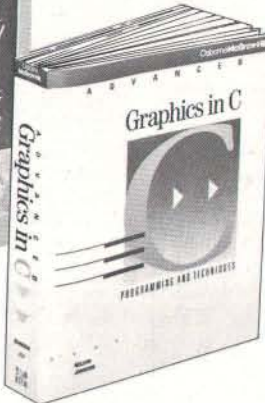
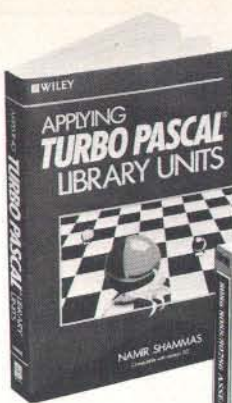

123: THE COMPLETE REFERENCE. By M. Campbell.
881005-1 Pub. Pr., \$22.95

PROGRAMMING IN C, Revised Ed. By S.G. Kochan.
584701-9 Pub. Pr., \$24.95

QUICK C PROGRAMMING FOR THE IBM. By C. Townsend.
584659-4 Pub. Pr., \$22.95

STRUCTURED PROGRAMMING IN ASSEMBLY LANGUAGE FOR THE IBM PC. By W. C. Runion.
584827-9 Pub. Pr., \$43.25

TELECOMMUNICATIONS AND DATA COMMUNICATIONS FACT-BOOK. By J. Abbatiello and R. Sarch.
606965-6 Pub. Pr., \$44.95

DATA TYPES AND DATA STRUCTURES. By J. J. Martin.
583689-0 Pub. Pr., \$45.00

WORDPERFECT®: THE COMPLETE REFERENCE. By K. Acerson.
881312-3 Pub. Pr., \$27.95

TROUBLESHOOTING AND REPAIRING THE NEW PERSONAL COMPUTERS. By A. Margolis.
583871-0 Pub. Pr., \$18.95

Any 3 books for \$1.00 each... if you join now and agree to purchase two more books—at handsome discounts—during your first year of membership.

MASTERING TURBO PASCAL 4.0, 2nd Ed. By T. Swan.
584762-0 Pub. Pr., \$22.95

DESIGNING USER INTERFACES FOR SOFTWARE. By J.S. Dumas.
584641-1 Pub. Pr., \$31.00

68000 ASSEMBLY LANGUAGE PROGRAMMING, 2nd Ed. By L. Leventhal; D. Hawkins; G. Kane & W. Cramer.
583817-6 Pub. Pr., \$28.95

C CHEST AND OTHER C TREASURES FROM DR. DOBB'S JOURNAL. Edited by A. Holub.
584807-4 Pub. Pr., \$24.95

HARD DISK MANAGEMENT IN THE PC & MS-DOS ENVIRONMENT. By T. Sheldon.
565/562 Pub. Pr., \$24.95

FILE ORGANIZATION FOR DATABASE DESIGN. By G. Wiederhold.
701/334 Pub. Pr., \$42.95

USING TURBO C. By H. Schildt.
881279-8 Pub. Pr., \$19.95

New! BYTE LARGE SYSTEMS Books

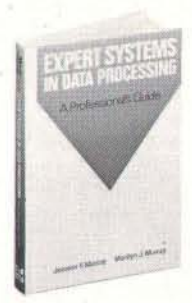
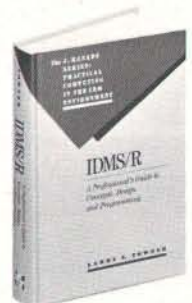

IDMS/R: A Professional's Guide to Concepts, Design and Programming. By L.E. Towner. 420 pp., illus. Tap the full potential of the Integrated Data Management System with this comprehensive guidebook. In three sections the book covers logical database design, physical database design, and database access and maintenance in a practical tutorial manner.
650/87X Pub. Pr., \$39.95

EXPERT SYSTEMS IN DATA PROCESSING: A Professional's Guide. By J.T. Murray and M.J. Murray. 237 pp., illus. Shows you how to successfully implement expert systems in a mainframe environment. From planning through implementation, it covers all the fundamentals... available shells and languages... frame-based system design... the IBM Expert System Environment... and sources for everything you'll need.
440/883 Pub. Pr., \$34.95

Here's how BYTE Book Club® works to serve you:

- **Important information . . . we make it easy to get!** Today, professionals who perform best are those who are best informed. For reliable, hands-on information, turn to the Byte Book Club. Every 3 or 4 weeks (12-15 times a year), members receive the Club Bulletin offering more than 30 books – the best, newest, most important books from all publishers.
- **Dependable service . . . we're here to help!** Whether you want information about a book or have a question about your membership, just call us toll-free or drop us a line. To get only the books you want, make your choice on the Reply Card and return it by the date specified. If you want the Main Selection, do nothing – it will be sent to you automatically. (A small shipping and handling charge is added to each shipment.)
- **Club convenience . . . we do the work!** You get a wide choice of books that

- simply cannot be matched by any bookstore. And all your books are conveniently delivered right to your door. You also get 10 full days to decide whether you want the Main Selection. (If the Club Bulletin ever comes late and you receive a Main Selection you don't want, return it for credit at our expense.)
- **Substantial savings . . . and a bonus program too!** You enjoy substantial discounts—up to 40%!—on every book you buy. Plus, you're automatically eligible for our Bonus Book Plan which allows you savings up to 70% on a wide selection of books.
- **Easy membership terms . . . it's worthwhile to belong!** Your only obligation is to purchase 2 more books – at handsome discounts – during the next 12 months, after which you enjoy the benefits of membership with no further obligation. You or the Club may cancel membership anytime thereafter.

Fill out the card and mail today! If the card is missing, write to:
BYTE Book Club®, P.O. Box 582, Hightstown, New Jersey 08520-9959
For faster service in enrolling, call 1-800-2-MCGRAW



PS/2 model 30/286	1949
PS/2 model 50/30 meg	2695
PS/2 model 70/60 meg	3895
PS/2 model 80/40 meg	4395
PS/2 model 70/120 meg	5595
PS/2 model 80/115 meg	6695

Call for other models



386 S 40 meg	Call Call
386 20E - 40 meg	4595
286 40 meg	2195
386 110 meg/25 MHz	7395
386 60 meg/25 MHz	5895
Portable III 40 meg/12 MHz	4095

CARD & MONITOR EXTRA
Call for other models



Mac-SE/20 Meg	2795
Mac-II/40 Meg	4249
Mac-SE-2 DR	2295
Call for 60 and 100 Meg	
Lazer NT	3595
Lazer NTX	Call

LOW PRICE LEADER

SINCE 1983

LAP-TOP

Compaq SLT 286-20	Call
SLT 286-40	Call
Toshiba T1000	769
T1200F	1395
T1200HB	2395
T1600	Call
T3100E	Call
T3200-40 Meg	3495
T5100	4495
Zenith Supersport	
286-20 Meg	3195
286-40 Meg	Call
8088-20 Meg	Call
Epson LT	Call
NEC Lap-Top	Call
Mitsubishi 286-20	2595

Toshiba Sale!
Call for all!



Step 286 - 12 & 16 MHz & 20 MHz
1 Meg RAM
Set up utility in ROM
S/P, C/C
Enhanced keyboard
1.2 MB floppy
DOS/BASIC

Call! for your configuration



Step 386-20 MHz & 16 MHz & 25 MHz
Up to 256K cache of very high speed RAM
2 Meg RAM, expandable to 16 Meg
S/P, C/C
Enhanced keyboard
1.2 MB floppy
DOS/BASIC

Call!



AST 286 model 140	2595
AST 286 model 80	1495
AST 386 model 300c	Call
AST 386 40 Meg	3195

CARD & MONITOR EXTRA
CALL FOR OTHER MODELS

WE STOCK

CITIZEN
OKIDATA
EVEREX
GOLD STAR

TOSHIBA
NEC
WYSE
HITACHI

PRINCETON GRAPHICS
SONY
ACER
HOUSTON INSTRUMENTS

AMDEK
HAYES
SAMSUNG
CALCOMP

PC MOUSE
MICROSOFT MICE
LOGITECH
MITSUBISHI

IRWIN & ARCHIVE
TAPE BACK
TAXAN
MAGNOVOX

BOARDS

Paradise VGA+	285
Vega VGA	299
Everex EVGA	265
Everex EGA	179
Tatung 16 bit	265

SOFTWARE SPECIALS

dBase IV	455
Wordperfect	239
Aldus Pagemaker	459
Ventura Publisher	495
Clipper	415
Quatro	145

NOVELL
Authorized Dealer

PRINTERS

EPSON

LX-800/LQ-500	195/315
LQ-850/1050	535/735

OKIDATA

320/321	359/490
390/391	490/649

TOSHIBA

321-SL/341-SL	475/595
351-SX 350 CPS	895

BROTHER

1709-9 PIN	425
1724-24 PIN	595

LASER PRINTERS

HP Laser II	1695
HP Desk Jet	585
Panasonic 4450	1549
Brother HL-8	1949
Nec LC 890	3195
PageLaser 12	\$\$\$\$

MONITORS

Nec Multisync IIA	525
Nec Multisync 3D	649
Nec Multisync Plus	899
Nec Multisync XL-19"	2295
Samsung EGA	359
Goldstar VGA	375

FAX MACHINES

Sharp FO 220	895
Sharp UX 350	1249
Canon	Call
Brother	Call
Richo	Call
Murata	Call

Intel Coprocessors

8087-3	105
8087-2	145
80287-8	235
80287-10	275
80387-16	409
80387-20	499
80387-25	599

MODEMS

Everex 1200 Int	89
Everex 2400 Int	159
Hayes 1200 B	289
More in Stock	Call

WE ACCEPT LC, CASHIER CHECKS, MONEY ORDERS, VISA, MC, AmEx
3% charge on VISA, MC & 5% on American Express

EXPORTS Available

COMPUTERLANE

HOURS:
M-S 9-6

1-800-526-3482 (Outside CA)
(818) 884-8644 (In CA)
(818) 884-8253 (FAX)

22107 ROSCOE BLVD.
CANOGA PARK
1/2 BLOCK W. OF TOPANGA
CA 91304

CORPORATE ACCOUNTS WELCOME
CALL FOR VOLUME DISCOUNTS
CONSULTANTS CALL FOR PRICING

Prices subject to change without notice

Compaq is a Registered Trademark of Compaq
IBM is a Registered Trademark of International Business Machines



Debunking 16-bit VGA

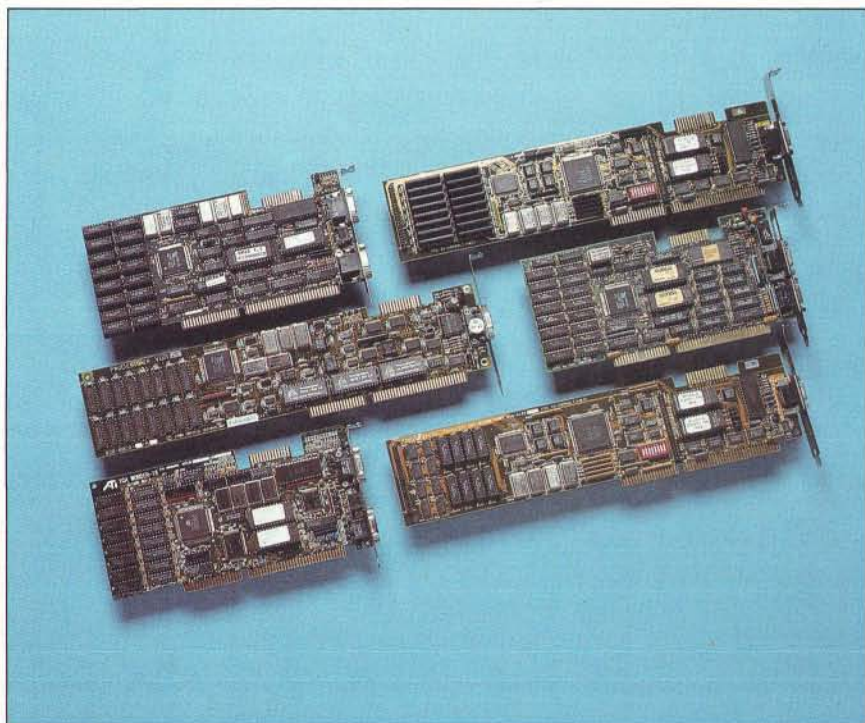

Design limitations
compromise potential
speed improvements
on 16-bit adapters

Bradley Dyck Klierer

Clockwise from top left: STB VGA EM-16, Headland Technology VRAM VGA, Genoa SuperVGA 5300/5400, Headland Technology FastWrite VGA, ATI VGAWonder, and Orchid ProDesigner VGA Plus.

VGA's success in establishing a new graphics standard is somewhat surprising. VGA resolution is slightly higher than its predecessor, EGA, and the larger palette adds a bit of flexibility. But while programmers prefer VGA with its readable registers, by and large, the differences between EGA and VGA are subtle.

Whatever the reasons, VGA has gained a huge following. To help their products stand out, engineers have added features like higher resolution modes and 16-bit adapters that make better use of the AT bus. One manufacturer, Headland Technology, has increased memory cycle speeds.

How different are these boards? To find out, I tested six 16-bit VGA cards: ATI's VGAWonder, Genoa's SuperVGA 5300/5400, Orchid's ProDesigner VGA

Plus, STB's VGA EM-16, and two from Headland Technology—VRAM VGA and FastWrite VGA.

Misleading Terms

What's a 16-bit board? The terminology can be misleading. VGA adapters have two types of memory: ROM, which contains the BIOS extensions necessary for the additional video modes, and RAM, which is the memory used to store text or graphics data. One or both may use 16-bit addressing.

Vendors tout 16-bit ROM, where the most significant benchmark improvements are evident. But most application programs don't make heavy use of the ROM BIOS—it's frequently used solely for setting the display mode and colors. The BIOS routines have always been slow at writing, so programmers bypass the BIOS and write data directly to RAM. Since the mode and color palette are seldom changed, fast ROM access is not particularly helpful.

Theoretically, 16-bit RAM access can dramatically improve performance. On a standard video adapter, a 16-bit write to RAM is implemented as two 8-bit writes, thus degrading performance. Text output is naturally suited to 16-bit writes; it's always represented by 1 byte for the ASCII code and a second byte for its attributes (e.g., color, background, and underlining). But graphics aren't as well suited for 16-bit writes. Graphics images are often manipulated one pixel, or bit, at a time (or as a collection of bits—such as a circle—that can't be represented as multiple linear bits).

One area where graphics frequently addresses blocks of contiguous pixels is in Windows-based applications. When you scroll or move the contents of a window, the adapter must copy blocks of pixels from one area to another (this is called a bit-block transfer, or bit-blt). To test this function, I wrote the benchmark program BITBLT, which copies a block

continued

Table 1: Results of the Small-C benchmark tests. Times are in seconds except for the SoftWest load/draw, which is in minutes:seconds.

	Video modes												
	SoftWest		Text			CGA		EGA			VGA		
	Load/draw	Regen	1	3	7	5	6	13	14	15	16	18	19
IBM display	1:59.7	36.0	20.76	20.81	20.81	2.30	2.20	5.16	5.77	4.17	5.72	5.93	2.14
VGAWonder													
640 × 480	1:59.8	35.9	13.79	13.23	13.35	2.25	2.14	5.60	5.60	4.11	5.60	5.76	2.14
800 × 600	2:17.9	47.8											
1024 × 768	2:23.3	52.8											
SuperVGA													
640 × 480	1:59.3	35.9	21.20	20.93	21.40	2.15	2.19	5.32	5.65	4.11	5.65	5.83	2.14
800 × 600	2:04.4	43.7											
1024 × 768	2:06.5	44.9											
ProDesigner													
640 × 480	2:00.4	36.0	13.84	13.62	13.62	2.30	2.19	5.17	5.49	4.12	5.55	5.66	2.14
800 × 600	2:02.9	39.9											
1024 × 768	2:03.5	41.1											
VGA EM-16													
640 × 480	2:00.0	35.9	19.94	19.61	19.61	2.15	2.19	5.33	5.65	4.12	5.65	5.82	2.14
800 × 600	2:02.5	40.0											
1024 × 768	2:03.3	40.2											
VRAM VGA													
640 × 480	1:58.7	35.7	13.30	12.97	13.10	2.30	2.30	5.21	5.33	4.10	5.33	5.49	2.30
800 × 600	2:24.7	50.7											
1024 × 768	2:25.1	52.2											
FastWrite													
640 × 480	1:59.1	35.7	13.35	13.10	13.13	2.80	2.30	5.38	5.39	4.10	5.38	5.55	2.30
800 × 600	Failed*	Failed*											
1024 × 768	2:25.2	52.2											

* Drawing did not complete (computer did not hang, but the display failed to update).

For a complete description of the benchmarks, see "Introducing the New BYTE Benchmarks," June 1988 BYTE.

Table 2: BITBLT test of adapter RAM speed. All times are in seconds.

		Video modes						
		5	6	13	14	16	18	19
IBM display	Byte	9.39	9.34	9.39	12.57	20.71	30.48	49.93
	Word	7.75	7.75	7.74	11.81	19.00	28.67	46.74
VGAWonder	Byte	16.64	9.56	8.57	9.44	16.26	22.41	36.69
	Word	8.34	9.50	8.24	9.34	16.21	22.24	18.40
SuperVGA	Byte	11.32	11.37	5.61	11.15	18.84	26.70	44.00
	Word	11.31	11.32	5.65	11.20	18.89	26.74	44.10
ProDesigner	Byte	10.82	10.71	5.38	10.54	17.91	25.10	40.21
	Word	9.56	9.62	4.84	9.45	16.36	22.52	20.15
VGA EM-16	Byte	11.37	11.43	5.66	11.21	18.95	26.92	44.21
	Word	11.42	11.48	5.71	11.26	19.60	26.96	22.14
VRAM VGA	Byte	7.80	5.88	3.95	5.87	10.11	13.84	22.85
	Word	6.48	3.68	3.30	3.68	6.31	8.57	14.12
FastWrite	Byte	9.89	6.86	5.00	6.81	11.64	16.90	26.59
	Word	9.34	5.11	4.67	5.60	8.35	12.80	19.67

Note: On modes 13 to 18, Word moves are ineffective because latch registers are only 8 bits wide. This results in incorrect colors.

of pixels to the entire screen byte by byte, then word by word. Flooding areas with a single color or a simple pattern is another potential application for bit-blts.

Unfortunately, the standard VGA has yet another 8-bit data path that can restrict fills and block moves. To conserve address space and simplify address calculations, EGA and VGA designers use bit-plane architecture. In a sense, several banks of memory are stacked in layers at one address (one plane for each bit of color, or four planes for 16 colors). The processor has to select which planes it must modify, but it has to preserve all planes, so the adapter temporarily stores the data in latch registers. Since VGA was designed as an 8-bit adapter, the latch registers are 8 bits wide. None of the reviewed adapters uses 16-bit latch registers, effectively limiting the bit-plane modes (i.e., all the EGA and VGA modes except 19, the 256-color VGA mode) to 8-bit operations.

Many factors besides data path width influence adapter speed. VGA adapters make heavy use of I/O registers, and since the I/O bus runs at the same speed (8 MHz) on most AT compatibles, there isn't much room for improvement here. Another factor is processor wait states. Both the CPU and the video controller must access video memory: As the CPU changes the memory contents, the video controller must read the memory and make the appropriate changes on the display. Most memory chips can't handle simultaneous access without creating snow on the display. So the video adapter adds wait states, preventing CPU access to display memory during certain intervals. This eliminates snow, but it slows writes to video memory.

Video RAM (VRAM), the approach used in Headland Technology's VRAM VGA, allows simultaneous access without snow. The other Headland Technology adapter, FastWrite VGA, uses a 1-byte memory cache. The cache can accept a write at any time without disturbing the controller. This strategy is most effective in text mode, where the CPU can write directly to the display without first reading the current data.

Finally, when dealing with extended modes, the software drivers supplied by a manufacturer can have a significant impact. The programmers may use an adapter's unique features to particular advantage (and poor programming may be an encumbrance).

Testing

I tested the adapters on an IBM PC AT with a 16-MHz Inboard 386/AT, 5.5

megabytes of memory, and an 80387 FPU. Operating systems used were PC-DOS 3.3 and OS/2 Extended Edition 1.1 (Presentation Manager). I used a Mitsubishi Diamond Scan HL6905 high-bandwidth monitor to test the highest resolution modes (1024 by 768 pixels). A standard multifrequency monitor should work well with other modes.

The test units all came fully configured with 512K bytes of RAM. The additional 256K bytes gives you a larger color palette in high-resolution modes.

I also tested for applications compatibility. I ran AutoCAD version 10, Windows/386 version 2.1, PageMaker 3.0, and Microsoft Flight Simulator 3.0. All adapters supported OS/2 and Flight Simulator without the use of special drivers and without problems.

The test programs include the BYTE Small-C video benchmarks plus the bit-blit function to test RAM speed. I also tested for the time required to maximize the PageMaker sample file PRODSPEC.PT3. (The test results appear in tables 1, 2, and 3, respectively.)

The AutoCAD and PageMaker test results are the best indicators of overall performance, followed by the standard Small-C tests in table 1. Results from the latter are a bit skewed because they don't take advantage of any of the boards' advanced features. The BITBLT test is a better indicator of board design than of overall performance improvement.

When examining the Small-C benchmarks, consider which modes you will use most frequently. Individual adapters tend not to perform as well over the full spectrum of tests. Some are faster at text modes; others are faster for specific sets of graphics modes. I divided the graphics results into CGA-, EGA-, and VGA-compatible modes. You might also want to consider mode 18 (640 by 480 pixels, 16 colors) and mode 19 (320 by 200 pixels, 256 colors) separately. For comparison, I included testing data for the IBM PS/2 display adapter (as run on the above system) in the table.

I had no compatibility problems with any of these cards. This comes as no surprise, since vendors have had nearly two years to refine their chip sets. Also, most of the companies used the same Tseng Labs ASIC (application-specific IC) as the controller for their boards. The two exceptions, Headland Technology and ATI, manufacture their own ASICs.

Using identical ASICs is no indication of an extended mode standard; support circuitry differs from manufacturer to manufacturer and can affect both performance and compatibility.

Table 3: This test measures the time required to maximize the PageMaker sample file PRODSPEC.PT3. I magnified a portion of the image and the descriptive text at 200 percent. All times are in seconds.

	Maximize
IBM display	4.8
VGAWonder¹ (VGA driver)	4.6
SuperVGA (VGA driver)	4.7
800 × 600	6.0
1024 × 768	8.3
ProDesigner² (VGA)	4.6
VGA EM-16³ (VGA driver)	4.7
800 × 600	5.5
VRAM VGA (VGA)	4.2
800 × 600	5.3
1024 × 768 (B&W)	5.6
FastWrite (VGA)	4.2
800 × 600	5.4

Note:

Maximize, a Windows function, expands a selected window to fill the entire screen.

¹VGAWonder has no Windows/386 drivers.

²ProDesigner has no Windows/386 drivers.

³VGA EM-16 has no 1024 × 800 Windows/386 driver.

The extended modes supported by the different BIOSes also differ. I tried mixing and matching a few drivers for the adapters that use the Tseng ASIC. While the drivers would operate, there were some minor inconsistencies (such as variations in color) when I used them on another manufacturer's adapter. A look at how each board performed follows.

Board Specifics

ATI VGAWonder. This board's distinguishing feature is the built-in Microsoft-compatible mouse. The adapter includes a two-button mouse built by Logitech, but you also can use a Microsoft InPort mouse. The mouse comes disabled; you enable it by selecting an interrupt line and port address via software. The mouse worked fine with the OS/2 version 1.1 Microsoft Mouse drivers.

VGAWonder will drive a standard multifrequency monitor, such as the NEC MultiSync II, at the full 1024 by 768 pixels in interlaced mode. While this monitor is less expensive than an HL6905 or an NEC MultiSync XL, the difference between 1024 by 768 pixels interlaced and 800 by 600 pixels noninterlaced is indistinguishable. A 1024- by 768-pixel display will show improved detail only in noninterlaced mode.

continued

	VGAWonder	SuperVGA 5300/5400	ProDesigner VGA Plus
Company	ATI Technologies 3761 Victoria Park Ave. Scarborough, Ontario, Canada M1W 3S2 (416) 756-0718	Genoa Systems Corp. 75 East Trimble Rd. San Jose, CA 95131 (408) 432-9090	Orchid Technology 45365 Northport Loop W Fremont, CA 94538 (415) 683-0300
Maximum resolution* Text (characters by lines)	132 × 44	132 × 60; 100 × 75	132 × 44
Graphics (pixels by pixels by colors)	800 × 600 × 256; 1024 × 768 × 16	800 × 600 × 256; 1024 × 768 × 16	800 × 600 × 256; 1024 × 768 × 16
Drivers	AutoCAD/AutoShade ADI; GEM 2 and 3; Lotus 1-2-3 and Symphony; Ventura Publisher 1.x and 2.0; Windows 1.x, 2.x, and Windows/286 2.x	AutoCAD/AutoShade ADI; GEM 2 and 3; Ventura Publisher 1.1 and 2.0; Framework II 1.1; Lotus 1-2-3 and Symphony; Windows 286 versions 1.03 and 2.x; Windows/386 version 2.03	AutoCAD/AutoShade ADI; GEM Desktop 1.0; Lotus 1-2-3 and Symphony; Ventura Publisher 1.x; Windows 1.x and 2.03; WordPerfect 5.0
Features	Includes Microsoft-compatible bus mouse; additional register-level compatibility with MDA, CGA, EGA, and Hercules adapters; supports digital and analog monitors; automatically detects monitor type	Supports digital or analog monitor; additional register-level compatibility with MDA, CGA, EGA, and Hercules adapters	Font-editing program; additional register-level compatibility with MDA, CGA, EGA, and Hercules adapters
Board size (inches)	8½ × 4½	8½ × 4½	13¼ × 3½
Documentation	User's manual	User's manual	Hardware manual; software manual
Price	256K-byte version: \$499 512K-byte version: \$699	Model 5300 (256K bytes): \$499 Model 5400 (512K bytes): \$699	512K-byte version: \$599
	Inquiry 851.	Inquiry 852.	Inquiry 853.

*For all adapters, the maximum graphics resolutions and number of colors require 512K bytes of memory.

To use noninterlaced mode, I had to override the board's automatic monitor detection, which identified the HL6905 as an 8514 (similarly, it identified the MultiSync II as a fixed-frequency PS/2 monitor). Fortunately, the monitor type is stored in nonvolatile memory, so you don't need to specify the monitor type every time you start the system.

The VGAWonder's typeface is noticeably different from that of the other adapters. You might want to view the text for yourself if you are considering the VGAWonder.

Genoa SuperVGA 5300/5400. The 5400 was the slowest board I tested. In fact, the benchmarks reveal that it is operating as an 8-bit adapter even though it has a 16-bit connector. The company is redesigning the card to use 16 bits. The SuperVGA is the only adapter in the group that supports Framework II. If you use Framework extensively, you might want to consider the SuperVGA. Other-

wise, wait for the redesigned adapter.

Orchid ProDesigner VGA Plus. ProDesigner performed reasonably well in all areas. The board has only two jumpers: One selects an 8-bit bus, and the other disables the NMI (nonmaskable interrupt, used to switch automatically to emulation modes). ProDesigner uses the same form factor as the IBM adapter, although it's missing the 44-pin Berg connectors near the card's center and end.

ProDesigner has no switches for selecting monitor type, and it doesn't automatically detect the type of monitor in use. It depends on you not to install drivers that run the display at higher resolutions than the monitor can support.

This was the least expensive 512K-byte board I reviewed. In fact, it's competitively priced against several of the 256K-byte adapters and is the only board with WordPerfect 5.0 drivers for that program's VIEW command. (This command puts the adapter in graphics mode

and displays a WYSIWYG page layout.) You can just make out the text on a full page view at 1024 by 768 pixels. If you need the features of a 512K-byte board or if you use WordPerfect 5.0 extensively, ProDesigner offers a good balance of price and performance.

STB VGA EM-16. The EM-16 performed well in all modes. It supports older, digital-type displays as well as analog monitors. This is a solidly built adapter, and the 256K-byte version was the best-priced board I tested.

Headland Technology VRAM VGA and FastWrite. VRAM VGA and FastWrite are more similar than different. The board layouts (which follow the IBM form factor) are identical except for the memory and memory-support circuitry on the end of the boards. Both VRAM VGA and FastWrite are very fast in text mode and average on graphics (although fills and moves are exceptionally quick).

Both boards had problems with the

VGA EM-16

STB Systems, Inc.
1651 North Glenville, Suite 210
Richardson, TX 75081
(214) 234-8750

132 × 44

800 × 600 × 256;
1024 × 768 × 16

AutoCAD/AutoShade ADI; GEM; Lotus 1-2-3
and Symphony; Ventura Publisher; Windows
1.x and 2.0x; Windows/386 version 2.1

Supports digital and analog monitors;
additional register-level compatibility with
MDA, CGA, EGA, and Hercules adapters

8½ × 4¼

User's manual

256K-byte version: \$449
512K-byte version: \$649

Inquiry 854.

1024- by 768-pixel modes (giving distorted colors and a sparkling effect while writing). Headland Technology attributes this to faulty ASICs in the early production runs. The company has since designed new testing procedures to prevent faulty boards from reaching the market. I received a replacement VRAM VGA that worked perfectly.

The AutoCAD drivers for both boards are surprisingly slow. FastWrite didn't finish drawing the SoftWest circuit board layout. AutoCAD kept running (i.e., the hard disk access continued), and while I was able to exit the program by typing "quit," the display stopped updating until I switched back to the AutoCAD menu. Regen would restart the display cycle, but it quit updating at the same place. This is most likely a problem with the drivers.

Windows/386 performance was excellent; the best option was the 1024- by 768-pixel monochrome mode of VRAM

VRAM VGA/FastWrite VGA

Headland Technology
46335 Landing Pkwy.
Fremont, CA 94538
(415) 656-7800

VRAM: 100 × 60; 132 × 43
FastWrite: 100 × 60; 132 × 43

VRAM: 800 × 600 × 256;
1024 × 768 × 16
FastWrite: 640 × 480 × 256;
1024 × 768 × 4

AutoCAD/AutoShade ADI; GEM 3; Lotus
1-2-3 and Symphony; Ventura Publisher;
Windows 2.03; Windows/386 version 2.1

VRAM VGA uses video RAM;
FastWrite uses a 1-byte memory cache

13¼ × 3¼

Hardware manual; software manual;
optional technical reference (\$25)

VRAM: \$799 (512K-byte upgrade: \$299)
FastWrite: \$599 (512K-byte upgrade: \$159)

Inquiry 855.

VGA. The VRAM VGA would be my adapter of choice for a desktop publishing system.

Discerning Performance

None of these adapters struck me as particularly outstanding. Certainly all are good alternatives to the standard 8-bit IBM adapter, especially considering the utility of the expanded resolution modes. When choosing an adapter, you should consider what applications you'll use most and focus your attention on the appropriate portion of the benchmarks and the list of supported drivers.

While working with the adapters, the only performance differences I noticed were in Windows/386 at 1024- by 768-pixel modes. The SuperVGA was sluggish, and the monochrome VRAM VGA driver was unusually fast.

For spreadsheets and word processing, good text-mode performance will give you an advantage. In standard text

modes, additional speed probably won't give you much more than blurry scrolling, but as the screen width increases to 132 columns (or additional rows), the added speed is definitely desirable. The Headland Technology and Orchid boards performed well in these tests.

Look to the AutoCAD and Small-C tests for good pixel-by-pixel performance. Applications such as CAD and business graphics packages will benefit the most from fast pixel operations. There is less differentiation here, probably because the 8-bit latch registers inhibit performance gains. The Orchid and STB drivers have the edge in high-resolution AutoCAD driver performance.

For desktop publishing, the Windows/386 and BITBLT benchmarks are good indicators. The STB and Headland Technology boards performed particularly well here. Special note should be made of VRAM VGA's monochrome 1024- by 768-pixel mode under Windows/386 (I couldn't discern any difference in speed from standard VGA resolution, although my test results show it was somewhat slower). I would gladly forsake color for the snappy response times.

Don't overlook the driver list. Most software requires special drivers to use the higher resolution modes. Notable exceptions are WordPerfect and WordStar, which use the mode set before entry (although you must patch WordStar or set WordPerfect to recognize the new screen size).

All the adapters show improved text-mode performance, but I'd like to see an adapter that uses 16-bit latch registers to improve graphics performance. Unfortunately, this would be difficult to implement as it would require extending many other VGA registers.

If you need better graphics performance and are willing to spend over \$1000, consider graphics coprocessor boards. I evaluated two in the January BYTE (see the review "Pixels on the March"). BYTE will take an in-depth look at more of these boards in an upcoming issue. ■

Editor's note: *The BITBLT test program is available on BIX as BITBLT. It's also available in a variety of other formats. See page 5 for details.*

Bradley Dyck Kliwer is the author of EGA/VGA: A Programmer's Reference Guide (New York: McGraw-Hill, 1988) and principal of DK Micro Consultants, a microcomputer consulting business in Bloomington, IN. He can be reached on BIX as "bkliwer."

Tatung super VGA: 1024 x 768

NEC™ super VGA: ooooooooops!

Even the great ones slip every now and then. For instance, NEC's Multisync 2A™ is a good Super VGA monitor. But our Super VGA monitors give you more of what Super VGA is all about: **maximizing every ounce of potential a VGA card can offer... no matter what card is used.**

Both brands offer 100% VGA and 800x600 compatibility. But, with appropriate cards, our Super VGA monitors will deliver

40% higher resolution. That's just part of the picture. Along with superior image quality, Tatung Super VGA monitors are more versatile, incredibly reliable, and more affordable. Check the chart.*

Tatung Super VGA. You have to see it to believe it. And you can see it at your Tatung dealer. Or call for complete details. We'll send them along with the name of the Tatung Dealer near you.

FEATURES	NEC Multisync 2A	Our CM-1496X	Our CM-1498X
Max. Res.	800 x 600	1024 x 768**	1024 x 768**
CRT Size	14"	14"	14"
Dot Pitch	0.31	0.31	0.28
IBM 8514™ Compatible	NO	YES	YES
Sugg. Retail	\$799	\$749	\$799
Maximum Resolution w/Graphic Card (Partial List)			
ATI VGA Wonder™	800 x 600	1024 x 768**	1024 x 768**
GENOA Super VGA Hi-Res Model 5400™	800 x 600	1024 x 768**	1024 x 768**
RENAISSANCE GRX RENDITION II/256™	800 x 600	1024 x 768**	1024 x 768**
STB VGA EM-16™	800 x 600	1024 x 768**	1024 x 768**
TECMAR VGA/AD™	800 x 600	1024 x 768**	1024 x 768**

**Interlaced



TATUNG

We monitor the world.

Tatung Company of America, Inc., 2850 El Presidio St., Long Beach, CA 90810 (213) 979-7055

Tatung Science & Technology, Inc., 2060 Ringwood Ave., San Jose, CA 95131 (408) 435-0140

Outside California: (800) 421-2929 - Eastern Region: (609) 395-6770

Circle 267 on Reader Service Card



Smalltalk/V Comes to the Mac



Discover the Mac's object-oriented roots

Ray Valdés

Smalltalk-80, created at the Xerox Palo Alto Research Center (PARC), is a language, a programming system, an application run-time environment, and a systems design philosophy. Digitalk's Smalltalk/V Mac implements much of the original system. Although it is new, Smalltalk/V Mac is a robust and mature product based on software technology that Digitalk has been developing for years.

Digitalk's original product, called Methods, supported a subset of Smalltalk-80 on IBM PC compatibles. Then came Smalltalk/V for AT compatibles. Now Smalltalk/V Mac adds substantial integration with the Macintosh hardware and software environments. For example, it includes Smalltalk classes that provide access to Macintosh system primitives and data structures.

The program files come in compressed form, and it takes 15 to 20 minutes to unpack everything. When installed, the system comprises a 600K-byte image file that contains all the objects in the system, an 80K-byte machine-language kernel, a 500K-byte file containing Smalltalk source code for most of the system, and four folders: Examples, Tutorial, User Primitives (C examples showing how to extend the low-level system primitives), and Tools.

The files in the Examples and Tutorial folders contain commented Smalltalk code that serves as both documents and sample Smalltalk programs. One file contains an eccentric but passable Prolog

interpreter written in Smalltalk.

The machine-language kernel that reads the image file comes in two versions: a Mac II version that takes advantage of the 68020 CPU, and a standard Mac version that uses the 68000.

Using the system is like running classic Smalltalk on a Xerox workstation or Smalltalk/V on the IBM PC, except that the user interface follows the Macintosh conventions. In classic Smalltalk, each window (and each window pane within a window) can have its own pop-up menu. In Smalltalk/V Mac, all windows share the single top-level menu bar. When you click on a window to activate it, the program redraws the top-level menu bar and any additional menu items that belong to the recently activated window.

What I call *classic* Smalltalk is the language as found on Xerox and Tektronix workstations and as described in the Addison-Wesley series of books by Adele Goldberg and others. A Xerox spin-off company, ParcPlace Systems, has enhanced this language and ported it

to various systems (including the Macintosh) while maintaining a high degree of compatibility. The ParcPlace product is also called Smalltalk-80.

The translation to the Mac user interface is smooth, with only one or two rough spots. For example, when using the Class Browser—a tool that you use to view and modify Smalltalk source code—it's not clear how to save a change. In classic Smalltalk, a pop-up menu would automatically appear, prompting you to accept the change. In Smalltalk/V Mac, you must go to the File menu and use the generic Save, which to me implies saving the image file.

Command-key equivalents for menu choices—another aspect of the Macintosh interface—simplify a number of operations. For example, in classic Smalltalk, you invoke the object inspector by way of a menu. You can do that in Smalltalk/V, too, but *command-I* is faster and easier. Another nice bit of Macintosh/Digitalk synergy has to do with user-

continued

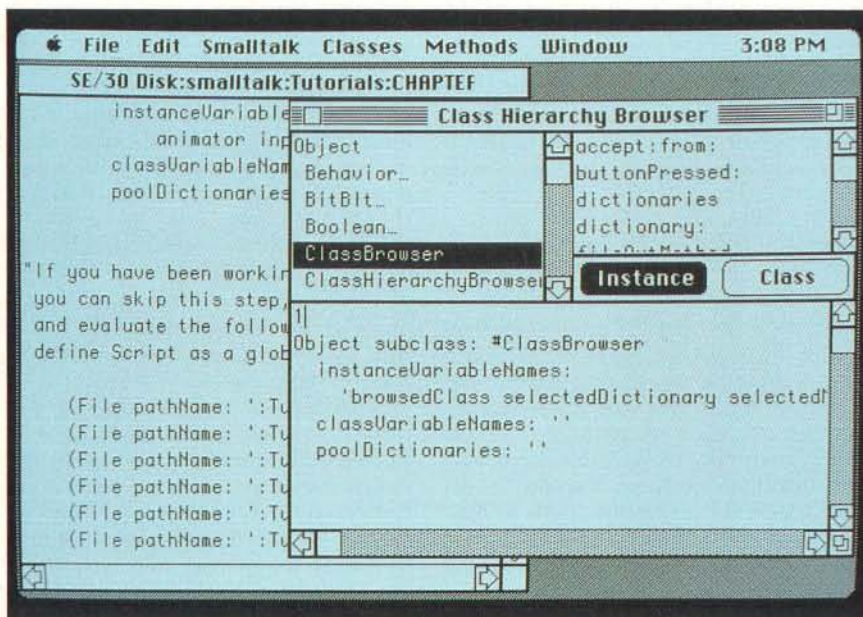

Smalltalk/V Mac

Type

Object-oriented programming system for the Mac Plus, SE, and II

Company

Digitalk, Inc.
9841 Airport Blvd.
Los Angeles, CA 90045
(213) 645-1082

Format

Two 800K-byte floppy disks

Hardware Needed

Mac Plus, SE, or II

Software Needed

System 5.0 or higher

Price

\$199.95

Inquiry 882.

defined primitives. When you want to control a serial port directly or add a graphical primitive, it's helpful to be able to drop into a compiled language. Smalltalk/V Mac can do this in a way that closely resembles HyperCard's XCMD mechanism.

The Pure Object-Oriented Approach

In Smalltalk everything is an object, including what most of us normally regard as procedures and data. For example, to add 3 and 4, you send an Add message to the 3 object, with 4 as a parameter. Both 3 and 4 are objects; more specifically, they're instances of the class SmallInteger. Smalltalk's object orientation is fundamental and all-encompassing. If you're making the transition to this style in the context of C++, Ada, or Modula-2, you will find it worthwhile to pick up a copy of Smalltalk/V.

The Smalltalk environment provides no clear distinction between one application program and another. Everything is an object or collection of objects, and all objects live in a kind of primordial soup called the *virtual image*. A virtual image is a snapshot of the running system. You save this image when you exit Smalltalk and reload it when you restart the system.

In Smalltalk, software development is an exploratory process. You mold existing objects and refine class definitions—themselves objects—to suit your purposes. Because Smalltalk/V is mostly implemented in Smalltalk code that's available for inspection, it offers a great

way to learn about constructing complex systems.

Unfortunately, that strength becomes a weakness if you're interested in building stand-alone applications. Smalltalk was designed for prototyping, not for commercial development. Digitalk addresses this limitation with a kind of linking tool called the Cloner. It streamlines a virtual image, eliminating all but the objects and class definitions that an application requires. The result is a Smalltalk program that behaves like a double-clickable Mac application.

Because Smalltalk was designed as an exploratory programming environment, you can dive right into Smalltalk/V. It provides several tools for exploring and modifying objects, most notably the Class Hierarchy Browser, which operates on class definitions. Others include the Inspector, the Debugger, the Class Browser, and the Method Browser.

At start-up, the system presents a transcript window. Here you can enter a snippet of Smalltalk code and then ask the system to execute. The following code lets you create a new window and draw a rectangle in it:

```
(Pen new)
  newWindow: 'Foo';
  drawRectangle: ((100@100)
  extent: (50@50))
```

You use the mouse to select and execute the text, and up pops a new window containing the rectangle you specified. To close the window, you just click on its close box and then forget about it. Smalltalk/V's garbage collector disposes of it automatically.

This procedure is simple when compared to the equivalent steps required to create, draw in, and dispose of a window in a Macintosh C programming environment such as Think C. Of course, a language like Macintosh QuickBASIC makes things easy, too, but I wouldn't try to build a complex system in BASIC. Smalltalk combines the convenience of an interpreted language with the power of the object-oriented approach. The proof is in the pudding: Smalltalk/V Mac is itself a complex system, and it's largely written in Smalltalk.

Smalltalk/V is a forgiving environment; you can't easily get into serious trouble. The worst thing that can happen is that you send a message to an object that doesn't exist, or you send a message to an object that doesn't know how to respond. In either case, the system activates a WalkBack window, which shows the most recent messages exchanged in

the current process. You can either resume execution—with no harm done—or activate the Debugger.

The whole system is surprisingly compact, given what it contains: a compiler, run-time library, virtual memory manager, multitasking process scheduler, graphics library, window manager, menu manager, dialogue manager, event manager, text editor, and source-level debugger. You get all these components as executable programs and also, with the exception of the compiler, as source code.

Making Connections

Most of the concepts in the Smalltalk language are simple and elegant. And its syntax—while more complicated than that of Lisp—is much simpler than that of C or C++. What's complicated is that everything seems connected to everything else. This is another of Smalltalk's strengths that is, from another perspective, also a weakness. Anyone used to procedural-language modularity often won't find items where they are expected. For example, the Process abstraction is implemented with a few methods in a subclass of OrderedCollection, which also happens to be the parent class to Array. Likewise, the equivalent of a FOR...LOOP construct in C is implemented in three lines of Smalltalk code in the class SmallInteger. The text editor is implemented by adding a few methods to subclasses of Dispatcher, Pane, BitBlit, and StringModel.

The whole system is reflexive in a fundamental way. Classes describe objects, and metaclasses describe classes. Both classes and metaclasses happen to be objects themselves. Because the system is interpretive, an object can change its own definition as it is running. In addition, by using the become: method, an object can transform itself into another kind of object. Although the system is remarkably responsive and forgiving, it is complex. Digitalk's tutorial provides welcome assistance. It leads you through a series of increasingly sophisticated examples; each example builds on the last. When you finish the tutorial, you've learned a lot about Smalltalk and Digitalk's implementation.

The documentation is excellent. A couple of omissions were addressed in the ReadMe file on the program disk. For example, the Digitalk implementation relies on certain critical global variables such as Processor (an instance of ProcessScheduler), Screen (an instance of GlobalDisplayScreen), and Keyboard-

continued

OS/2 NEWS

Volume 1, No. 4.

A continuing report on advanced software for personal computers.

Sophisticated reminder system helps you automate your processing tasks.

Enyart Development Corporation has started distributing Tickler/2.[™] This advanced automated reminder system lets the user create a series of reminders to occur before, during and/or after an event. Tickler/2 can even remind your computer when to perform certain tasks. Because it can be used in conjunction with your data base, spreadsheet, E-mail and project management software, it gives you amazing versatility. For example, you could set up Tickler/2 to take a previously generated sales forecast spreadsheet, update it daily, print a report and electronically mail it to another computer at the end of every week...all while you're on vacation. For more information on the advanced capabilities of Tickler/2 call 1 303 286-8686.

PC Paintbrush now available for Presentation Manager.

The OS/2[™] version of PC Paintbrush[®] uses Presentation Manager[™] to make creative expression fun, fast and easy. PC Paintbrush for OS/2 is a graphics creation package that includes all the features of the DOS-based version. It lets you create intricate free-hand graphics using the various brushes, lines, curves, colors and patterns. You can also use scores of drawing and text tools to create presentation-quality documents. For more information call ZSoft at 1 404 428-0008.



Microsoft[®]

Word processing that goes beyond just words is introduced for OS/2.

DisplayWrite 5/2 Composer[™] has been released by IBM. This advanced word processing software lets you scan photos and line art into your document, position them anywhere on the page, even make text flow around them...all without cutting or pasting. DisplayWrite 5/2 Composer capitalizes on the protected mode and multitasking capabilities of the IBM OS/2 environment so you can run it as a foreground or background operation. See your IBM Authorized Dealer or IBM marketing representative for complete information.

New relational data base system helps PC users handle large volumes of data.

R:BASE[®] is an easy-to-use OS/2 relational data base management system that features both menu and command-line interfaces. And because it includes LAN support for up to three simultaneous users (using the multitasking and networking support enhancements of OS/2), it's cost-effective as well. R:BASE also provides programming language support, and over 70 business and scientific functions are already integrated into the program. For more information on how R:BASE can help you manage large volumes of data call MICRORIM at 1 800 624-0810.

Symantec's Q&A provides powerful file management for OS/2.

Q&A[™] is an integrated flat-file data base and word processor that offers OS/2 users a unique combination of power and simplicity. With Q&A you can take advantage of OS/2 benefits like multitasking and large memory. Q&A OS/2 also offers the ability to share data bases on a network with the DOS version of Q&A. Multifile lookup in Q&A means you can merge data from multiple Q&A data bases into customer-designed forms and reports. Q&A's executive word processor lets you create presentation-quality documents and easily perform mail merge with your data.

For more information on how Q&A can solve your data base and word processing needs call 1 408 253-9600.

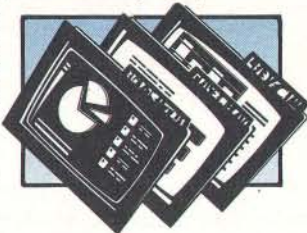

OS/2-based Platinum provides true multitasking accounting packages.

The Platinum[®] Series of fifteen accounting modules from Advanced Business Microsystems is a business accounting tool so powerful that on a single computer you can print and post several hundred invoices and checks, run a reconciliation, generate consolidated financial statements—and enter new budget figures at the same time. Platinum also makes it easy for you to integrate your accounting data with data bases, spreadsheets, presentation graphics, word processing, desktop publishing and other applications. For more information on Platinum call 1 800 999-1809.

Free OS/2 Application Guide available.

You can receive a 340-page OS/2 Application Guide that lists and describes over 800 identified applications for the OS/2 operating system. For a free copy of this guide call 1 800 IBM-2468, ext. 120.

IBM[®]

Semaphore (an instance of Semaphore). The manual mentions these but doesn't explain them well. The index, which is much too short, doesn't even have an entry for Screen.

I also would have appreciated a discussion of the differences between Digitalk's implementation of Smalltalk and the classic Xerox implementation. These differences are considerable—not so much in the language as in the environment—and will make porting a complex

program to Smalltalk-80 a difficult endeavor.

Smalltalk/V vs. Smalltalk-80

In terms of syntax and semantics—though the language hasn't been defined in a way that ensures portability—Smalltalk/V is very close to classic Smalltalk. However, at the level of methods and libraries of classes, the two implementations diverge. The ParcPlace product builds on classes described in the Addi-

son-Wesley literature. Digitalk, probably for copyright reasons, has implemented the same classes differently. For example, with classic Smalltalk, you can group methods into categories known as class protocols; the FileStream class contains protocols for file access, positioning, and status. With Digitalk's Smalltalk, you can group methods only by class.

The net result is that a large Smalltalk-80 program is portable to Digitalk's Smalltalk/V, but only with much effort. Any porting efforts will likely be irreversible, although this won't be an issue for most people.

Smalltalk/V Mac differs from its PC counterpart, too. Digitalk has provided classes that allow access to Macintosh ROM services and data structures. For example, you can use the class EventRecord to access the data structures described in *Inside Macintosh*, or the trap primitive to access any Macintosh trap function. Of course, using these Mac-specific functions makes it difficult to port your programs to Digitalk's PC Smalltalk.

In theory, because Smalltalk is interpretive, you can use the system as a tool for exploring the Macintosh ROM Toolbox. In practice, this is harder than you might think. Both Smalltalk and the Macintosh ROM Toolbox were designed as self-contained, complete graphical environments. If you want to focus on the native Macintosh interface, Smalltalk distorts the picture considerably.

Smalltalk/V Mac performs well—no mean feat when you consider the mismatch between the requirements of a pure object-oriented language like Smalltalk and the architecture of conventional CPUs like the 68000 and 80286.

Recent implementors of Smalltalk, including both Digitalk and ParcPlace Systems, have developed proprietary techniques for overcoming this architectural mismatch. Whatever techniques Digitalk used, they represent an impressive achievement.

Digitalk's Smalltalk/V Mac is an excellent, reasonably priced product. It's a great way to learn about object-oriented programming and Smalltalk. It's also a way to construct commercial applications that port from the Mac to the PC. ■

Ray Valdés is president and founder of Sapphire Software, a technology consulting firm in San Francisco, California, that specializes in the design and development of graphics software. He can be reached on BIX c/o "editors."

SUNDAY 10-5

PROMPT DELIVERY

GRAPHIC CARD	ATI VGA Wonder 299.99	Paradise VGA Plus 294.99	Paradise VGA P16 449.99	Paradise VGA Pro 339.99	Video 7 VGA B 339.99	Video 7 Ram VGA 459.99
LAPTOP COMPAQ	286 SLT 20 MB 3949.99	286 SLT 40 MB 3949.99	DATAVEIL EL BACKLIT 984.99	640K 2-TONK F/D 49.99		
NEC	Multi Speed EL II 1649.99	Multi Speed HD 20 1649.99	NEC Ultra 286/20 286/20 389.99	NEC Pro Speed 386/40 389.99		
TOSHIBA	T-1000 1749.99	T-1200 2 F/D 1274.99	T-1200 H 20 MB 1844.99	T-1200 Backlit 2 F/D 3099.99	T-1600 20 MB w/ram 2899.99	T-1600 20 MB 2899.99
ZENITH	184-12 F/D 1949.99	184-2 F/D 20 MB 2949.99	286 1 F/D 40 MB 4299.99	286 1 F/D 40 MB 4299.99	386 1 F/D 40 MB 4299.99	386 1 F/D 40 MB 4299.99
MODEMS	U.S. ROBOTICS 270.00	Courier HST-2450 575.00	FAX BOARDS 299.99	Quad Fax Port 299.99	Quad Fax Inter. 299.99	
PRINTERS	Diconix 150 295.99	Diconix 300 Wide 499.99	Epson FX-850 434.99	Epson FX-1090 299.99	Epson LQ-500 584.99	Epson LQ-850 709.99
CASIO	SE 4000 209.99	SHARP Wizard 8 Lamp 7000 94.99	Time Expense Mgr 8 Lamp 7000 94.99	Thermaprint Dictionary 209.99		
MONITORS	Mitsubishi Sync 479.99	NEC MultiSync GS 239.00	NEC MultiSync II 489.99	NEC MultiSync II 649.99	NEC MultiSync 3D 249.99	NEC MultiPlus 249.00
SEAGATE DRIVES	20 MB W/Chk 269.00	30 MB W/Chk 345.00	40 MB 4MS 399.00	40 MB 4MS 449.99	40 MB 4MS 449.99	60 MB 28 MS 575.99
COMPUTERS	AST PREM386 C/ 23MHz 1 MB 2 F/D 799.00	AST 286 8 MHz 152K 1 F/D 499.00	AST 286 8 MHz 152K 1 F/D 499.00	AST PREM 286 512K 1.2 F/D 40 MB HD 1499.00	Compaq Deskpro 286 12 MHz 1 F/D 40 MB HD 1959.99	Compaq Deskpro 386 20 MHz 1.2 F/D 40 MB HD w/EGA Board 3999.00
LASER PRINTER	Apple Laser II NT 3490.00	Canon Series III 1399.99	HP Desk Jet 1584.99	HP Laser Jet II 319.00	1 MB RAM Hardip 2729.99	3009.99
HAND SCANNERS	NEC LC-890 199.00	400 DPI NEW 89.99				
FACSIMILE	Canon Fax 8 629.99	Canon Fax 15 599.99	Multix 1600 699.99	Paradise KFX-100 919.99	Paradise KFX-120 924.99	Paradise Fax UF-140 1299.99
POCKET ORGANIZER	Call					
APPLE	Mac SE/30 40 MB 929.00	Mac II 1.3 MBK Df. 1279.00	Mac SE 2 800K 2199.00	Mac SE 2 MB RAM 4999.99	Mac II 4 MB RAM 729.00	Mac II 80 MB 429.00
MOUSE	Logitech w/Softw. 39.99	Logitech C-7 67.99	Logitech Clear Case 69.99	Logitech Hi Res 79.99	New Logi Hi Res Str 95.00	

WORLDWIDE INQUIRIES PROMPTLY FILLED

GUARANTEED LOWEST PRICES

1-800-874-1235

TOLL FREE OUT OF N.Y.: IN N.Y.S. (800) 223-6779 — N.Y.C. (212) 463-8330
 IN CANADA TOLL FREE 1-800-666-1668 FAX # 212-463-8335

S & W COMPUTERS & ELECTRONICS
 31 West 21 Street, New York, N.Y. 10011
 Hours: Sun. 10-5, Mon-Thurs 9-8, Fri 9-2 Sat. Closed

Prices subject to change without notice.
 * DISCOVER, M.C., VISA, C.O.D. S.H. Add.
 * Not responsible for typographical errors.
 Prices are for consumers.
 Returns without written authorization.
 ©1988

ALL MERCHANDISE SHIPPED IN FACTORY SEALED CARTONS, 100% GUARANTEED

Domesticating Microsoft Windows



CASE:W gets
Windows programmers
up to speed quickly

Alex Lane

Microsoft Windows, like the Macintosh, makes life easy for users but hard for programmers. Now CASE:W 1.0 (computer-aided software engineering for Windows) lightens the programmer's load, too. It's a tool for constructing skeletal Windows applications, and it's also a Windows application that manages menus, resource script files, icons, and dialog boxes in a WYSIWYG context.

You start with an untitled application window whose menu bar contains no entries. Then you add menu items, specifying whether they lead to pop-up options, dialog boxes, or application-specific code. At any point, you can generate Windows source files, compile them, and run the resulting program. It won't do anything except behave like a normal Windows program. You've still got to add application-specific code, but anyone who's struggled with the often-bewildering Windows programming environment knows that getting even the most minimal Windows program to work is a nontrivial accomplishment. A tool like CASE:W, which does this automatically, will make a lot of friends.

CASE:W is a kind of expert system. It knows about the structure of Windows programs and uses that knowledge to generate C source files, resource files, and make files. But CASEWorks downplays the AI aspect of its product and stresses its value as a CASE tool for Win-

dows. I find this approach refreshing.

The software is easy to install. The manual isn't lengthy, but it doesn't need to be. CASE:W is so easy to use that I kept racing ahead of the tutorial and, in short order, built a trivial Windows program. It probably would have taken me several days if I had to work only with Microsoft's tools and its voluminous documentation.

CASE:W requires an IBM AT, PS/2, or compatible with an Intel 80286 or 80386 microprocessor, a minimum of 2 megabytes of RAM, a hard disk drive with at least 400K bytes of free space, EGA or VGA graphics with a monitor, and a Windows-compatible mouse. The memory requirement is a Microsoft recommendation for running Windows; CASE:W itself requires less than 64K bytes of memory. On the software side, you will need DOS 3.0 or higher; Windows 2.03, Windows 286, or Windows/386; the Windows Software Development Kit (WSDK); and Microsoft C

Compiler 5.0 or higher.

I examined CASE:W 1.0 on an ARC 386i microcomputer equipped with a mouse, VGA with a multisync monitor, 3 megabytes of 16-bit memory, and a hard disk drive. My system's software configuration included MS-DOS 3.3, Windows/386 version 2.1, version 5.0 of the C Compiler, and the WSDK.

A Tour of CASE:W

CASE:W comes up as a full-screen Windows application. Database (.APP) files contain the information CASE:W uses to generate source files for Windows programs. Once you load an application database, the CASE:W menu bar offers these items: File, Design, Tools, Generate, Edit, Make, Run, and Options. F1 activates a context-sensitive help system.

The File item contains options for loading and saving CASE:W application files. A Setup option specifies tools accessible from within CASE:W. Initially,

continued

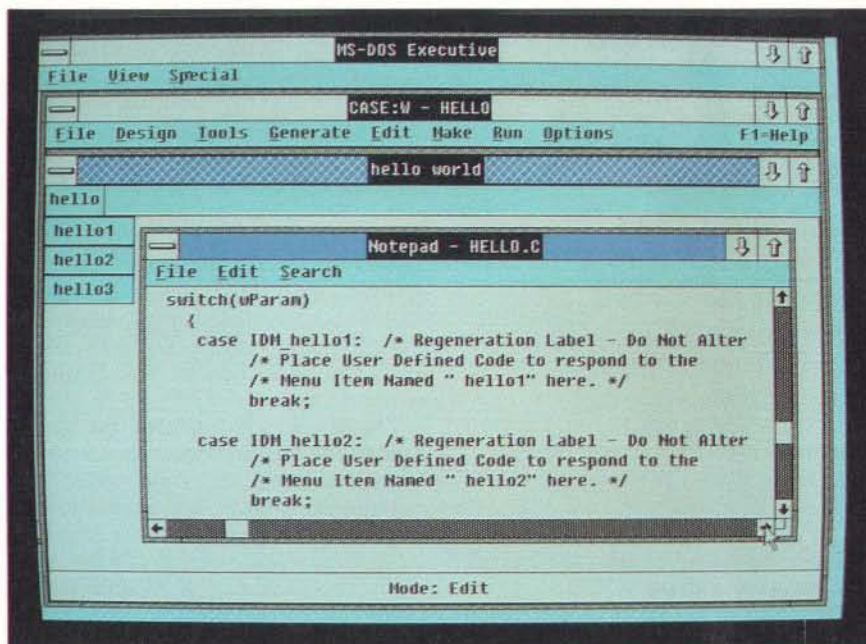

CASE:W 1.0

Type

Programming aid for Microsoft Windows

Company

CASEWorks, Inc.
1 Dunwoody Park
Atlanta, GA 30338
(404) 399-6236

Format

One 360K-byte 5¼-inch floppy disk and one 720K-byte 3½-inch floppy disk

Hardware Needed

IBM AT, PS/2, or compatible with an Intel 80286 or 80386 microprocessor, at least 2 megabytes of RAM, a hard disk drive with at least 400K bytes of free space, EGA or VGA graphics with a monitor, and a Windows-compatible mouse

Software Needed

DOS 3.0 or higher; Windows 2.03, Windows 286, or Windows/386; Windows Software Development Kit; Microsoft C Compiler 5.0 or higher

Price

\$795

Inquiry 881.

these are the dialogue, font, and icon editors that come with the WSDK.

The heart of CASE:W is the Design item. It presents options related to four major areas of Windows design: Program Configuration, Main Window, Menu and Popup System, and Client Area. Once you select one of these, CASE:W puts a prototype window on the screen and places the system in design mode. The prototype window occupies the client area of CASE:W's own window and displays a title bar and a menu bar for the application being built. The title bar has a crosshatched background that distinguishes it from the title bar of a genuine Windows application. This cuts down on confusion, especially when other Windows applications are on the screen with CASE:W.

The Program Configuration option manipulates compiler options, libraries, standard code and data segments, imports, and exports. Main Window controls your application window's title, icon, cursor, font, size, location, and colors. Menu and Popup System enables you to add, delete, or move menu items. Client Area leads to a dialog box that you use to incorporate WSDK-built dialog

boxes into your application.

As is typical with Windows programs, there are formal ways to do things in the CASE:W environment, and there are shortcuts. For example, if you want to add a menu item, you can select Menu and Popup System from the Design menu item and then select Add Menu Item from the Options menu. Or you can just use the mouse to click on the menu bar of the application you're developing. That brings up the Add Menu Item dialog box directly. I found these shortcuts helpful and intuitive.

Once you've got your application's interface looking the way you want, you use Generate to produce the necessary sources, Make to compile them, and Run to test the resulting Windows program. The Generate item uses CASE:W's inference engine to create a header (.H) file, one or more program (.C) files, a make file, a module definition (.DEF) file, and a resource script (.RS) file. The make file calls the Microsoft make program, which in turn activates both the resource compiler and the C compiler. You track the progress of these utilities in a character-mode window that CASE:W provides.

The header file includes the global handles used by the application program for colors, pens, and so on, and it also contains the #define statements for various labels used to process, for example, menu items. The program file (or files, if you direct CASE:W to modularize the code) contains ordinary C source code for the application. Instead of mashing all parameter information into one line, the function declarations generated by CASE:W follow the pre-ANSI pattern—one function parameter per line:

```
long FAR PASCAL WndProc(hWnd,
    lMessage, wParam, lParam)
HWND hWnd;
unsigned lMessage;
WORD wParam;
LONG lParam;
{...
```

The C file has a commented area at the top for your declarations and another commented area at the end for your code. CASE:W indents code sensibly and inserts comments that are personalized for your application. For example, you'll see comments like

```
/* Menu Item Named " &Open" here */
```

instead of

```
/* Second Menu Item here */
```

You don't need to edit CASE:W's code, but once you get your interface working and are into the guts of your application, you'll want to edit the application-specific code that you insert into CASE:W's program skeleton. The Edit item provides for this. By default, it runs the Windows Notebook editor, but you can specify another Windows editor or a character-based editor for which a .PIF file exists. The bottom line is that you can continuously edit, compile, link, and run Windows programs without leaving the Windows environment.

The Big Picture

Everyone's first C program is the four-liner that writes "Hello, world!" on the screen. The program illustrates a number of snack-size concepts—header files, the central function called main(), and the printf() function. The simplest program you can write in the Windows environment—a program that creates a resizable window on the screen—is an order of magnitude more complex. CASE:W built a 6500-byte C source file to accomplish the task, as well as the obligatory header and resource file.

In ordinary C, the environment calls main() with two optional arguments commonly named argc and argv; these denote the number of arguments on the program's command line and an array of pointers to the string tokens on the command line. Compare this to the central Windows function, WinMain(). It requires four arguments: Its own instance handle, a previous instance handle (or NULL, if no other instance of the program is running), a pointer to the parameter line, and an argument that tells the application whether to appear as a window or an icon. Note that you must already know quite a bit about Windows (e.g., what handles and instances are, and what it means to start an application as an icon) before you can start putting together a WinMain() function call.

Whereas an ordinary C program may have a lot or a little formal organization, the Windows program must have, within its main body, an initialization section, a message-polling loop, and a closing section. You also have to provide a window procedure that interprets messages sent to your program from the Windows environment, and a paint procedure that will update your application's window when Windows asks it to. This explanation is, of course, over-simplified, and, if you're not a Windows programmer, it undoubtedly sounds like technobabble.

In short, the complexity of Windows programming makes it nearly impossible

to become familiar with Windows in a piecemeal manner, as is the case with C. You can't just dip your toe into the pool to get a feel for the water; you have to jump into the deep end and start swimming.

To test the efficacy of CASE:W, I set out to duplicate (to the extent possible) the features of an application my company had developed for a client nearly a year ago. It was the first Windows project for the programmer that worked on the application, and from what I observed, it wasn't a pretty sight. His desk was piled high with manuals and trade books. Marked-up printouts littered the floor. Long hours went into learning enough about Windows to get started—yet the application was simple. Two items on the menu bar led to a limited set of options, and about a half-dozen dialog boxes needed to be integrated into the application. There was also quite a bit of user-specific code.

With CASE:W, I could duplicate the menu bar and pop-up options completely and, with little difficulty, integrate the dialog boxes into the CASE:W code. It took me about two hours with most of my time spent integrating the dialog boxes.

To its credit, I often forgot I was using CASE:W. I got completely absorbed in adding *this* menu item or *that* icon into the application I was creating. At no time did the program tempt me to take out a stopwatch and clock its speed. As far as time is concerned, I substantially duplicated in hours the skeleton of a Windows application that took an experienced programmer a couple of days to build.

I can see several uses for CASE:W in a production environment. First, novices and experts alike can profitably use it alone to generate the skeletons of Windows applications. In addition, using CASE:W would offer novice Windows programmers the opportunity to create working code that they could examine in detail. Third, software specifiers could use it to supplement (or supplant) written specifications and to present developers with a core of Windows source files ready to be fleshed out.

Despite the aid provided by CASE:W, you will need to do more to create a complete, useful application. For example, you must write those portions of the code that make your application more than just a resizable window. In this respect, CASE:W leaves your application-specific code alone. You don't have to laboriously reintegrate your code every time the program regenerates source files. Instead, you can simply flesh out your parts of the application while still

modifying the interface.

Unlike some 1.0 products I've seen, CASE:W is not a slapdash attempt at getting a product out the door. It has some minor bugs. For example, I noticed a sporadic corruption of the generated C source files; the company promises to fix this in version 1.1. But in general, the product works as advertised with no hitches. I deeply regret not having had it a year ago. I'm sure its cost would have been repaid several times over by now.

Windows will remain a popular user interface on IBM AT-style machines for some time to come. CASE:W will help those who program in the Windows environment to concentrate on the *what* of their applications rather than on the *how*. ■

Alex Lane is a senior knowledge engineering consultant with Technology Applications, Inc., of Jacksonville, Florida. He can be reached on BIX as "a.lane."

WHY DESIGN YOUR PRODUCT AROUND A COMPUTER?

Design the computer in.

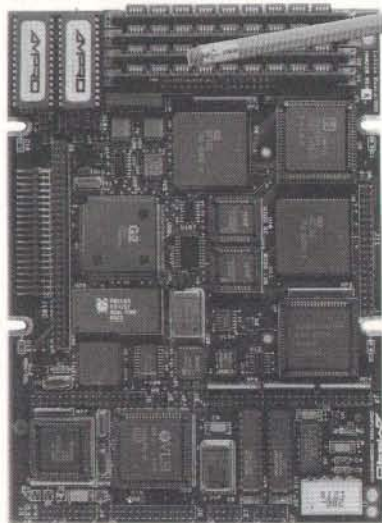

Little Board™/286

Built-in vs. built-around. External systems mean boxes, boards, backplanes, cables, and reliability problems. Ampro's Little Boards give you a complete system on a single board you can build right into your product.

Small size. Big power. Eliminate the bulk and constraints of multi-board, backplane-based systems. Embed a Little Board that requires just 2/3rds the power and volume of a 5¼" floppy drive. But with the full power of a PC or AT®.

Fully compatible. Little Board/286 and Little Board/PC are functionally identical to multi-board PCs and ATs. They run PC-DOS™ 2.0 to 3.X. They run DOS languages, compilers and applications. You'll be standing on a proven foundation of hardware and software.

Ampro's Single Board Systems. It's all there. Up to a Megabyte of RAM. RS-232C and Parallel ports. AT/PC-compatible controllers and bus expansion. EGA/CGA/MDA and Hercules™.

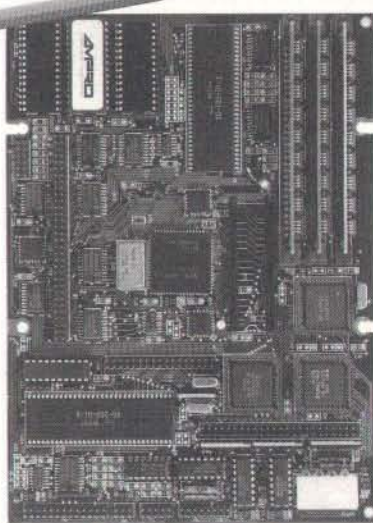

Little Board/PC

compatible video options. Even optional solid-state disk. Plus SCSI support for hard disk, tape, optical drives, bubble drives ... you name it. And, low power consumption (+5VDC, less than 8W) and a wide operating temperature range (0 to 60°C). Perfect for standalone operation and harsh environments.

Anywhere that reliability is a critical consideration. Available worldwide. For information and the name of your nearest U.S. or international Ampro representative, call us at the number below. Or write for Little Board Product information.

Now includes DR-DOS™

408-734-2800

Fax: 408-734-2939 TLX: 4940302

AMPRO
COMPUTERS, INCORPORATED
1130 Mountain View/Alviso Road
Sunnyvale, CA 94089

Reps: Australia—61 3 720-3298; Austria—43-222/45 45 01; Canada—(604) 438-0028; Denmark—45 3 86 20 20; Finland—358 0 585-322; France—331 4502-1800; Germany, West—49 89 611-6151; Israel—972 3 49-16-85; Italy—39 6 811-9406; Japan—81 3 257-2630; Netherlands—010-411 85 20; Spain—34 3 204-2098; Sweden—46 8 55-00-65; Switzerland—41 1 740-41-05; United Kingdom—44 2 964-35511; USA—contact AMPRO

Trademarks: IBM, AT—IBM Corp.; Hercules—Hercules Computer Technology, Inc.; Little Board—Ampro Computers, Inc.; DR-DOS—Digital Research, Inc.

FLEXSCAN™ 9070S, PC Hi-Res That Looks Like a Million.

The FLEXSCAN 9070 Multiple Scan monitor is of course compatible with other multi-scans, but includes improvements that will give you the professional edge which is the mark of a good investment.

You can extend your multi-scan range from 20kHz to 50kHz in practical terms. This means that, at the 48-50 kHz range, you can make use of PC CAD/CAE capabilities at a resolution of up to 1024 dots × 768 lines. The FLEXSCAN 9070 takes advantage of non-interlace high resolution signal as high as 1024 × 768 to provide you with a flicker free display at much brightness. You can also use the 9070 with IBM PS/2 or VGA compatible boards at a high resolution mode like 800 × 600 and 1024 × 768 (non-interlace).

The FLEXSCAN 9070 provides a 16-inch screen, large enough for CAD/CAE and 3-D projections, yet small enough to fit comfortably into your home work space.



1024 dots × 768 lines Graphics (Non-interlace)
AutoCAD

Also, for your convenience, all controls and switches, including the alternate video input, are located within easy reach on the front panel. The FLEXSCAN 9070 is compatible with a wide range of IBM, Apple, and other products, allow you to use all of today's popular programs---at a resolution that looks like a million.

FLEXSCAN™ MODEL 9070S

- IBM VGA (PS/2), 8514/A, PGC, EGA compatible and CAD/CAE use.
- Apple Mac II and SuperMac Spectrum compatible
- Max. 1280 dots × 800 lines high resolution
- 1024 dots × 768 lines display on Non-Interlace signal delivers flicker-free high-res graphics
- 20kHz to 50kHz horizontal scan automatic adjustment. 50Hz to 80Hz vertical scan automatic adjustment
- 16 inch, 0.31mm dot pitch and newly developed XF (Extended Field) Gun to obtain both brightness and sharp focus.
- Front mounted controls including the input signal select switch between 2 video input.
- Selecting white or Amber displays colored application in shades of gray or amber
- Tilt-Swivel stand standard

NANA O®

NANA O USA CORPORATION

23510 TELO AVE., SUITE 5 TORRANCE, CA 90505
PHONE (213) 325-5202 FAX (213) 530-1679

Specifications are subject to change without notice.

APPLE, Macintosh II are registered trademarks of Apple Computers Inc. ARTIST, ARTIST I Plus, ARTIST 10, ARTIST 10/16 are trademarks of Control Systems Inc. IBM, PS/2, PC, XT, AT and PS/2 are registered trademarks of International Business Machines Corporation. SuperMac is a trademark of SuperMac Technology. SuperEGA HiRes, SuperVGA and SuperVGA HiRes are trademarks of Genoa System Corporation. Orchid Designer VGA, Orchid Designer VGA-2, TurboEGA and TurboVGA are trademarks of Orchid Technology. Paradise VGA Professional Card, Paradise VGA Plus Card and Autoswitch EGA are trademarks of Paradise Systems, Inc. Paradise Systems is a registered trademark of Paradise Systems, Inc. VEGA Deluxe and VEGA VGA are trademarks of Video-seven Inc. Mathews is a registered trademark of Mathews Corporation. Imagraph is a trademark of Imagraph Corporation. AutoCAD is a registered trademark of Autodesk Inc. GEM is a registered trademark of Digital Research Inc. Lotus and 1-2-3 are registered trademarks of Lotus Development Corporation. SigmaVGA and SigmaEGA are trademarks of Sigma designs, Inc. FLEXSCAN is a trademark of NANA O CORPORATION. NANA O is a registered trademark of NANA O CORPORATION.



Clarix CAD

Clarix's first CAD program is more than just another MacDraw

Paul Tuten

A lot of people have wondered what kind of CAD program Clarix, the Apple spin-off company, would come up with. Well, now they know the answer. And if they use MacDraw II, they should feel right at home with Clarix CAD, because its design is based on MacDraw II.

In a nutshell, Clarix CAD is a two-dimensional drafting program with accuracy to five decimal places. It sells for \$799, and MacDraw II owners can upgrade to Clarix CAD for \$399. But don't think Clarix CAD is just a new release of MacDraw II—Clarix CAD is powerful enough to compete head-to-head with VersaCAD for the Mac.

The Clarix CAD package comes with ample documentation and a videotape that introduces Clarix CAD's drawing concepts of tools, methods, and modifiers. In addition to the program and utilities disks, a tutorial disk has a series of exercises that you complete using a workbook. With the videotape and exercises, you can get up to speed right away.

To run Clarix CAD, you'll need a hard disk drive and at least 1 megabyte of memory; you'll need more memory if you use a large-screen monitor or Multi-Finder. Clarix CAD also supports a color monitor on the Mac II. You can produce color documents and black-and-white printouts of four-color separations on the Imagewriter II or a plotter. The utilities disk includes MacPlot Configure and MacPlot Driver, which allow you to use

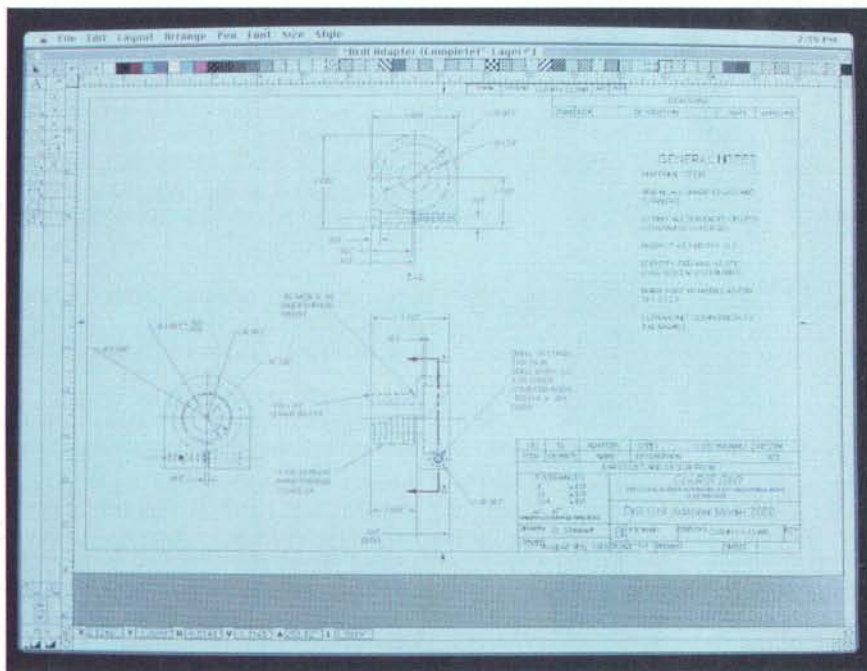

Hewlett-Packard, Houston Instrument, and compatible plotters.

Familiar Look with Different Feel

Clarix CAD provides a familiar look: a document window—or in this case, a drawing window—with all the standard Macintosh features. You can have up to seven drawing windows open at once, and you can also open MacDraw, MacDraw II, and PICT files from within Clarix CAD. You can open special windows that contain library objects. The package includes a Berol Rapidesign Sampler of library symbols. You can also save drawings in the PICT format for later use in other Macintosh applications.

It's easy to enlarge a drawing or reduce it so that all geometry fits in the current window size, giving you a view of the entire document. To save time scrolling around a drawing, you can save and recall up to nine different views of it.

Clarix CAD lets you save a drawing as

“stationery” that, when opened, creates a new untitled drawing that has all the settings and drawing elements of the original drawing. One obvious use would be to set up stationery documents with your company title block in different drawing sizes.

Besides the usual Undo, Cut, Copy, Paste, Clear, and Duplicate options, the Edit menu also contains Linear and Polar Duplicate. With Linear Duplicate you can copy objects in one or two directions and enter the total number of copies for each direction. You can also key in the x and y distances and specify them as increments between the copies or distribute the copies equally along that distance. Polar Duplicate works much the same way. You enter the total number of copies for distribution or increment in angular degrees and radius from center, the coordinate (x,y) center of rotation, and whether to rotate each copy normal to

continued

Claris CAD 1.0

Type

CAD program

Company

Claris Corp.
440 Clyde Ave.
Mountain View, CA 94043
(415) 960-1500

Format

Three 3½-inch floppy disks

Hardware Needed

Apple Macintosh Plus, SE, II, or IIX with a hard disk drive

Software Needed

System 6.0 or higher

Documentation

486-page user's reference manual

Price

\$799

Inquiry 884.

radials. Together, these two commands relieve you of the tedium of precisely placing replicate objects.

Other useful features include Trim and Smooth. Trim took some time for me to get used to, but it is a powerful option for removing unwanted geometry and trimming the ends of lines relative to other geometry. It saves having to completely redraw an object just to correct minor errors. Smooth lets you polish off the rough edges of splines, polygons, and freehand shapes. Also interesting is how the familiar Show Clipboard takes on an added dimension in Claris CAD. You can flip, change angle, and change the *x,y* scale of objects on the clipboard before pasting them into drawings.

Claris CAD permits you to use multiple scales in a single drawing—for drawing details and so forth—by allowing up to 255 different “rulers” per drawing. You can move the zero point of the rulers anywhere within the drawing space. Also, Claris CAD supports multiple layers, and you can work with objects on more than one layer at a time.

As for other features, you can set the drawing “pens” to inch, millimeter, or point sizes. And you can select standard hatch patterns for iron, bronze, steel, rubber, aluminum, glass, and lead. You can even edit the spacing and angle of the hatch lines and create new hatch patterns. You can also define up to 16,000 different black-and-white patterns and 16,000 different color patterns.

Snap-on Tools

At first glance, Claris CAD's tool icons look ordinary enough. For creating geometry, the tool icons include Line, Rectangle, Square, Fillet, Chamfer, Rounded rectangle, Circle, Concentric circle, Ellipse, Circular arc, Elliptical arc, Freehand shape, Spline curve, Polygon, Double lines, Regular polygon, and Circle center tools. Dimension tools include Linear, Chain, Datum, Angular, Diametral, and Radial.

Beneath the column of tool icons is a pop-up menu of Method icons. Most of the drawing tools can create objects in several ways, and the icons in the Methods menu reflect those different ways. For example, when the Line tool is selected, you can construct a line from endpoint to endpoint or from center point to endpoint, or draw an unlimited-length line through a point. When the Circle tool is selected, you can draw the circle by center point and radius, by two points on the diameter, by three points on the circumference, or by a radius and two points on the circumference.

Claris CAD also has a group of Modifier icons that you use with either the drawing or selection tools. With these modifiers you can place objects in precise locations and in specific relationships to each other. Positional modifiers include Any point, Endpoint, Center point, Intersection point, Invisible intersection point, Point on object, Corner, and Percent along length.

You use these modifiers in conjunction with drawing tools to locate specific points as you draw an object. For example, to connect a line to the endpoint of another line, you use the Line tool and the Endpoint modifier. The Endpoint modifier automatically finds the endpoint of the existing line and connects the line you are drawing to it. You can then finish the line by selecting the Center point modifier and an existing circle, for example. The Center point modifier finds the center of the existing circle and connects the end of the new line to it.

Geometric constraint modifiers include Perpendicular, Tangent, and Offset. For example, to draw a line perpendicular to a line and tangent to a circle, you use the Line tool and the Perpendicular modifier, select the existing line, and then select the Tangent modifier and the existing circle. Offset can create a line parallel to an existing line, concentric arcs, circles, squares, and ellipses.

Selection tool modifiers, supported by a pop-up menu, let you use the selection arrow tool to adjust the size, shape, and position of objects. The selection arrow

default is Resize; this is the way selection arrows behave in most Macintosh applications, dragging a handle to resize, dragging the object to move it.

This CAD Can

Claris CAD's approach of tool, method, and modifier combinations provides great latitude in the drawing process. One of its best modifiers is the Location bar. The Location bar is not merely a readout of the cursor coordinates but also an input panel for interactively keying in object creation data, such as center coordinate location and radius for a circle.

Also important is that after you select a tool icon, you can draw an object from the keyboard. If you need a modifier to draw the object, a key equivalent exists. You then only need the mouse to select the modifying geometry. There are key equivalents for most menu commands.

I even discovered that the Chamfer tool can be used as a corner tool by entering a zero chamfer length. I could then easily trim and extend nonparallel lines to their intersection point.

There is one minor annoyance. While you can easily create drawings with details drawn at different scales, the only way you can associate the details with the rulers used when drawing them is to store views of them with Set View. When you recall the views, the rulers displayed will be the ones displayed when you set the view. If you forget to display the proper rulers when setting the view or forget to set the view altogether, determining the scale of a detail can be a tedious process. But that's what drawing notes are for.

In many ways, I found Claris CAD comparable to VersaCAD for the Mac. Both are accurate, and both have positional and geometric modifiers, symbol libraries, hatching, and automatic dimensioning. VersaCAD has more sophisticated spline drawing and group building capabilities, plus the HyperCard utilities and IGES and DXF file translators. The question is, at over twice the price, do you really need those features?

Besides, I prefer Claris CAD's Location bar to VersaCAD's Input window for keyboard entry. Also, Claris CAD ran fast on my stock Macintosh SE; VersaCAD did not. The cost of an accelerator board or Mac II adds considerably to the price of VersaCAD. Even so, Claris CAD is not a hands-down winner over VersaCAD but a viable alternative. ■

Paul Tuten of Wichita, Kansas, is a tool-engineering contractor for the aircraft industry who uses a CAD system daily. He can be reached on BIX c/o "editors."

Our MAJOR ADVANTAGE-Supplying you with the Broadest Range of Software Ammunition.



ADVANTAGE SOFTWARE

	LIST OURS	
BACKUP UTILITIES		
Copy II PC	40	20
DS Backup 4.0 (MAC)	70	46
FASTBACK/MAC	129	73
FASTBACK Plus	189	113
Intelligent Backup	150	129

	LIST OURS	
CAD		
AutoCAD	2850	CALL
AutoSketch	80	65
Speed Enhanced Version	90	79
Claris CAD	799	CALL
DesignCAD	300	160
Drafix 1 Plus	295	189
Generic CADD Level 3	200	109

	LIST OURS	
COMMUNICATIONS		
Carbon Copy plus	195	117
Crosstalk Mk.4	245	132
Crosstalk XVI	195	95
Mirror III	100	90
Procomm Plus	75	52
Red Ryder (MAC)	80	59
RELAY Gold	295	130
Remote 2	195	101
Smartcom III	249	151

	LIST OURS	
DATA ACQUISITION/ANALYSIS		
Asystant	495	429
DADISP	795	719
LABTECH Notebook	995	799

	LIST OURS	
DATABASE		
Clipper	695	439
dBASE III Plus	695	399
dBASE IV	795	485
dBASE IV Devel. Edition	1295	899
dBASE MAC	495	322
dBXL	169	119
FoxBASE+	395	249
FoxBASE+/MAC	395	210
MS FILE (MAC)	195	131
Paradox 3.0	725	543
PFS:Professional File	249	149
QuickSilver	599	369
Q&A	349	213
R&R	150	109
VP-Info	125	99

	LIST OURS	
DESKTOP PUBLISHING		
Adobe Illustrator '88 (MAC)	495	359
Draw Applause	495	303
GEM Artline	495	297
GEM Desktop Publisher	299	178
PageMaker	695	523
PFS:First Publisher	99	75
Ready, Set, Go (MAC)	495	320
Ventura Publisher	895	525

	LIST OURS	
DISK/FILE UTILITIES		
1 DIR Plus	95	52
Command Plus	80	68
Cubit	70	47
Magellan	139	CALL
MKS Toolkit	199	155
Norton Commander	89	41
Software Carousel	80	45
Tree86	90	68
XTree	70	37
XTreePro	129	71

	LIST OURS	
FILE TRANSFER		
Laplink Plus	140	64
Laplink (MAC)	140	85
Software Bridge	149	121
Brooklyn Bridge	140	85

	LIST OURS	
INFORMATION ORGANIZERS		
Agenda	395	CALL
askSam	295	209
GOfer	80	43
GrandView	295	179
Guide	275	218
Memory Lane	149	127
Memory Mate	70	43
PackRat	395	284
SideKick Plus	200	149
Tornado	100	75
Who-What-When	189	139
ZyIndex Professional	295	159

	LIST OURS	
INTEGRATED SOFTWARE		
Framework III	695	465
Lotus Symphony	695	CALL
Microsoft Works	149	99
Microsoft Works (MAC)	295	203
SmartWare	895	476

	LIST OURS	
LANGUAGES		
Lahey FORTRAN F77L	350	319
Lattice C 3.4	450	289
Lightspeed C (MAC)	249	179
Lightspeed Pascal (MAC)	229	165
Micro Focus COBOL/2	900	CALL
w/Toolset	1800	1499
Microsoft C	450	299
Microsoft COBOL	900	599
Microsoft FORTRAN	450	299
Microsoft FORTRAN (MAC)	295	195
Microsoft Macro Assembler	150	103
Microsoft Pascal	300	199
QuickBASIC	99	69
QuickBASIC (MAC)	99	69
QuickC 2.0	99	69
Turbo Assembler/Debugger	150	112
Turbo Basic	100	75
Turbo C 2.0	150	112
Turbo C Professional	250	185
Turbo Pascal 5.0	150	112
Turbo Pascal Professional	250	187

	LIST OURS	
MATHEMATICAL TOOLBOXES		
Derive	200	166
Eureka: The Solver	167	125
Gauss	395	350
MathCAD 2.0	349	218
Mathematica (MAC)	795	675
Matlab	695	659
TKI Solver Plus	395	277

	LIST OURS	
MULTIPURPOSE UTILITIES		
MACE GOLD	150	79
MACE Utilities	100	53
Norton Utilities	100	50
Norton Utilities Advanced	150	85
PC Tools Deluxe	79	40
PC Tools (MAC)	79	40
Symantec Utilities (MAC)	100	63
V feature Deluxe	120	117

	LIST OURS	
OBJECT-ORIENTED LANGUAGES		
Actor	495	423
C_talk	150	137
Smalltalk/V	100	85
Smalltalk/V 286	200	169
Smalltalk/V Mac	200	169
Zortech C++	150	135
w/ source	250	209

	LIST OURS	
OPTIMIZING UTILITIES		
Disk Optimizer	70	42
Fast Trax	60	42
V CACHE	60	51

	LIST OURS	
PCB ARTWORK/SCHEMATICS		
Micro-CAP III	1495	1269
Pspice (MAC)	1450	1327
smARTWORK	895	824
Tango-PCB Series II	595	569

	LIST OURS	
PRESENTATION GRAPHICS		
Chart-Master	375	205
Concorde	695	509
Cricket Graph (MAC)	195	132

	LIST OURS	
SPREADSHEETS		
20/20	500	301
Ability Plus	199	139
Javelin Plus	395	CALL
Lotus 1-2-3	495	CALL
Lucid 3-D	100	CALL
Microsoft Excel	495	249
Microsoft Excel (MAC)	395	CALL
Microsoft Multiplan (MAC)	195	128
PFS:Professional Plan	249	CALL
PlanPerfect	395	193
Quattro	248	186
Silk	150	CALL
Smart Spreadsheet	399	CALL
SuperCalc5	495	329
Trapeze (MAC)	295	190
VP-Planner Plus	249	125
Wingz (MAC)	495	CALL

	LIST OURS	
SPREADSHEET ADD-ONS		
4Views	150	119
4Word	100	61
Allways	150	91
@ Liberty	99	92
Hal	150	CALL
Inword	100	55
Look & Link	100	55
Note-It Plus	80	49
Noteworthy	80	49
R&R (Lotus)	149	109
SeeMore	80	43
Sideways	70	43
SmartNotes	80	43
Spellint!	80	49

	LIST OURS	
STATISTICS		
CSS	495	482
GAUSS Math & Stat System	395	350
Microstat II	395	328
NWA StatPak	399	366
SPSS/PC+	795	727
StatGraphics	895	CALL
StatPac Gold	595	545
SYSTAT	595	488
SYSTAT (MAC)	595	421
SYSTAT (w/ SYGRAPH)	795	732

PRIMARY TARGET Harvard Graphics

The number one selling business graphics software. And why not? Harvard Graphics is easy to use and offers a wide variety of chart and graph types to choose from. Harvard Graphics is also very flexible for defining and saving templates of frequently used chart styles. Other features include a macro utility, batch printing, straight-forward importing and exporting facilities, and a built-in spelling checker for proof-reading words and numbers in data charts.

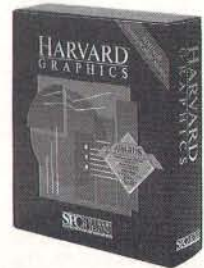

SRC SOFTWARE PUBLISHING
A Division of Voyager Software Corp.

List: \$495

Ours: \$279

Freelance Plus	495	CALL
GEM Graph Present. Pack	495	307
Graph-in-the-Box	140	108
Graphwriter II	495	CALL
Harvard Graphics	495	279
Microsoft Chart (MAC)	125	83
Perspective Junior	149	77
PIXIE	195	117
Xerox Presents	495	325

	LIST OURS	
PROJECT MANAGEMENT		
Harvard Total Project Mgr.	695	446
InstaPlan 2.0	99	95
MacProject II	495	379
Micro Planner	595	419
Microsoft Project	495	331
SuperProject Plus	495	267
Time Line v. 3.0	595	345

	LIST OURS	
WORD PROCESSING		
Ami	149	102
DisplayWrite 4	495	342
FullWrite Prof. (MAC)	295	236
MacWrite 5.0 (MAC)	125	90
Manuscript	495	CALL
Microsoft Word	450	240
Microsoft Word (MAC)	395	275
Multimate Advantage II	565	CALL
Q & A Write	199	119
RightWriter	95	51
Sanna Word IV	595	313
Smart Word Processor	299	CALL
Sprint	200	149
Timeslips III	200	115
Word Perfect 5.0	495	255
Word Perfect (MAC)	395	237
WordStar 2000+	495	258
WordStar Professional 5.0	495	245

Terms & Policies

All prices subject to change without notice. We accept Visa, MC, AMEX (2% surcharge on AMEX). Shipping \$4 per item sent UPS Ground. Allow 14 days for personal/company check clearance. Returns subject to 15% restocking fee. RA # required. PO's welcome from Fortune 1000 and other qualified organizations.



ADVANTAGE SOFTWARE

A Division of Voyager Software Corp

In the U.S. call:

1-800-333-3141

N.Y. / International **914-332-0756**

Fax: **914-332-4021**

55 South Broadway, Suite B, Tarrytown, NY 10591

Circle 11 on Reader Service Card

The CalComp DrawingBoard™ Digitizer Family.

Now in A, B and C sizes.

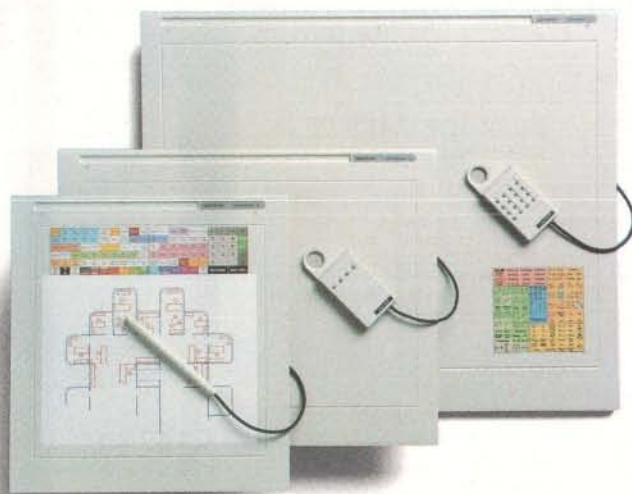

1. **Flexibility.** Quick menu picking. Also high resolution tracing and drawing. And selective resolutions of up to 1,016 lines per inch.

2. **Features users want most.** Sleek, rugged, wedge shape. Convenient built-in stylus holder. Adjustable plane positions. Power on indicator. Removable template overlay holder. Color matched to most PCs and workstations.

3. **CalCompatibility.** Supports over 50 major CAD and graphics software packages. AutoCAD, VersaCAD, Zenographics Mirage, and Ventura Publisher. Just to name a few.

4. **Built-in reliability.** CalComp's advanced technology reduces the number of electrical components.

5. **Warranty commitment.** We back our DrawingBoard with a special five year warranty, too.

With DrawingBoard you get a complete digitizing system, including your choice of a 4 button cursor and pen stylus. Or a 16 button cursor instead. Plus power supply and cable. Combine all this with a low price. And there's only one conclusion you can draw on. CalComp's DrawingBoard digitizers.

Call us at 1-800-CALCOMP. Or write us at CalComp, P.O. Box 3250, Anaheim, CA 92803.

We draw on
your imagination.™

We draw on your imagination and DrawingBoard are trademarks of CalComp Inc. Mirage and Autumn are trademarks of Zenographics. AutoCAD is a trademark of AutoDesk. VersaCAD is a trademark of VersaCAD Corporation. © 1988 CalComp Inc. Ventura Publisher is a trademark of Ventura Software, Inc.

 **CalComp**
A Lockheed Company



Corel Draw Shows Great Promise

An advanced drawing and graphics program could be the best yet for the IBM PC AT

Sue Rosenberg

This could be the best yet: a versatile graphics tool set for IBM PC ATs and compatibles that lets you manipulate scanned images or create your own. With the extensive typesetting and drawing controls all in one package, you can produce high-quality graphics for dot-matrix, LaserJet, and PostScript printers and desktop publishing programs. It's called Corel Draw, and it could sway graphic artists away from the Macintosh.

To use Corel Draw 1.1, you'll need Microsoft Windows 2.0 or higher, EGA or higher graphics, a printer, and a mouse or graphics tablet. Included in the \$495 package are a program disk, font disk, clip-art disk and handbook, user's manual, quick-reference cards, videotape tutorial, and typesetter's ruler. I tested Corel Draw on an AT compatible with a Paradise VGA board and a Logitech Mouse.

Less Is More

Corel's screen display is similar to that of most drawing programs. It uses a virtual 32-inch by 32-inch sketch pad with a drop-shadowed rectangle to indicate the printable page area.

The surprise is that there are fewer icon tools than in most other drawing programs—only Select, Zoom, Rectangle, Ellipse, Outline, Fill, Pencil, Shape, and Text. However, the tools have



great versatility. Corel Draw has no rounded rectangle tool because you create rounded rectangles by pushing on one corner of a rectangle with the shape tool. It has no separate arc or wedge tools because the shape tool creates them from ellipses.

When you work on the sketch pad, you create only an outline of the drawing—a sketch that needs its outline inked in and areas painted with color. The Outline tool controls the angle, shape, and width of the pen nib, the ink color, the type of line it draws, and PostScript halftone screens. The Fill tool specifies the interior color, parameters and colors for fountain fill, and PostScript screens and textures.

Outline and Fill can be spot or process colors, and you can select one type for the outline and another for the interior of the object. Spot colors are defined using the Pantone Matching System. Process colors combine specified percentages of cyan, yellow, magenta, and black

(CMYK) for more than a million selections. Corel dithers colors for display in the color selection box and on the preview screen.

The Pencil tool forms all line drawings—straight lines, polygons, and free-hand curves. Corel calculates the mathematical equation of the Bezier curves needed to produce the shape you draw and then redraws the image. You control how closely the redraw follows every bump in your drawing, how it decides whether a segment is a straight line or curve type, when a corner should be smooth or cusped, and how close you must get to an end for line segments to be joined automatically.

For line drawings, the Shape tool becomes a "node editor" to add, delete, cut, paste, change the shape, and even change the underlying mathematical equation of each segment of the curve. A menu command, Convert to Curve, transforms rectangle, ellipse, and text

continued

Corel Draw 1.1

Type

Advanced drawing program

Company

Corel Systems Corp.
1600 Carling Ave.
Ottawa, Ontario K1Z 8R7, Canada
(613) 728-8200

Format

Three 1.2-megabyte 5¼-inch floppy disks

Hardware Needed

IBM PC AT or compatible with hard disk drive; EGA, VGA, or Hercules graphics card; printer; mouse or digitizing tablet

Software Needed

Microsoft Windows 2.0 or higher

Documentation

User's manual; videotape tutorial (VHS); clip-art handbook; quick-reference cards

Price

\$495

Inquiry 883.

objects into curves so you can then edit the underlying shapes.

The Text tool sets type—up to 250 characters at one time—using one of some 50 fonts in a point size taken from a range of from 1 to 999, including fractional sizes. Selecting individual characters with the Shape tool lets you mix fonts, produce subscripts and superscripts, rotate, change horizontal and vertical alignment, modify point size, and kern text interactively. You can edit text even after it has been rotated, skewed, stretched, mirrored, and fitted to a curve. However, the only changes you can make are insert and delete. There are no commands to cut and paste or to convert between uppercase and lowercase.

Adding to Corel's power are numerous menu commands and keyboard shortcuts. One favorite of mine is Repeat, which repeats the last action you performed on the next object you select. You can also define macros to repeat a series of commands.

Corel's commands are sufficiently intuitive, and if you are familiar with other drawing programs, you'll have almost no need to refer to the manual. I say "almost" because there's no on-line help to

tell you about neat shortcuts, like pressing the space bar to activate the previously selected tool. Read the manual in any case. It's excellent, everything a manual should be—clearly written and well organized with extensive step-by-step illustrations, many of which are also supplied as Corel Draw files. A two-hour videotape provides more training in basic techniques.

Warhol à la Corel

To test Corel, I attempted to duplicate a Campbell's Tomato Soup can label as closely as possible. I was inspired by Andy Warhol, of course, but it was a good choice of subject. To reproduce the label's diverse graphical elements requires nearly all of Corel's commands.

I started with the Campbell's logo. None of the script texts came close enough to the swirling "C" of the logo, so I started with an ellipse that I rotated, opened into an arc, and converted to a curve. Using the Shape tool, I added a node to anchor the outline where the line changed directions.

It took half a dozen different fonts to form the other nine characters in the logo, demonstrating the power of the program to manipulate text. The text editor's dialog box shows only one character of a selected font, but you can choose which character to display. That option turned out to be particularly helpful when I was looking for specific letters and characters.

Type for "CONDENSED" is appropriately condensed vertically but diluted horizontally. There are two ways to change the horizontal and vertical proportions independently: the visual, in which a selected object is transformed by selecting a handle and moving the pointing device; and the mechanical, a menu selection, where you perform transformations by entering numbers in a dialog box. Visual transformations, such as shrinking, skewing, and mirroring, take effect relative to the side or corner opposite the handle. Mechanical transformations occur relative to the center line of the object.

Since I had not yet moved the word to its final resting place, I found the visual approach easier for me to judge when the letters were at the proper height. I used the Select tool to condense the height of the letters and then used the Shape tool to grab a handle at the end of a text string to change the intercharacter spacing. "Tomato" was the next word I tried. One of the many fonts supplied with Corel Draw approximates the font used for "Tomato" on the soup can label, but it needed

minor modifications. I typed "Tomato," selected the font, and then converted the text to curves. This time, using the Shape tool, I selected all left-side serifs and moved them at once so that they would be converted equally. That worked, so I moved the right-side serifs. Then I squared each "o."

Producing the label's seal was also easy. Text fitted to a curve is the simplest process of all. Corel does all the hard work for you. I just drew the curve and told Corel to fit the text to the curve.

I used the ellipse, rectangle, and line-drawing shapes to form the rest of the seal. Rather than reproduce exactly the intertwined figures on the seal, I scribbled an approximation with the Pencil tool and then used the Shape tool and node editor to remove extra lines and reposition others. I suspect that the reason the Shape tool worked flawlessly here was that it was manipulating objects that were created as curves, not converted to curves.

Portions of the soup can label that I had anticipated having difficulties with turned out to be incredibly easy to assemble. I compiled the fleur-de-lis border from an imported clip-art image. I made a minor adjustment to the image, colored it, set up a grid, and then replicated the image snapped to the grid to ensure an evenly spaced border.

Similarly, "SOUP," with a double outline and a rotated "O," was an easy process. I just typed the word, rotated the "O," duplicated the image on top of itself, and added color. With a judicious selection of pen widths, the outline of the back image peeked out from behind the front.

To speed up the drawing process, Corel Draw shows the picture in color and with proper pen widths only when preview mode is active. Both the drawing board and preview mode can appear side by side on-screen, and adjustments to the drawing can be reproduced immediately in the preview window, displaying the proper pen widths and colors. You can also specify that only the selected portions of the object are to be updated in the preview window when a change is made to the drawing.

Bit-Mapped Imports

I also checked out the way Corel handles bit-mapped images. In particular, I wanted to see how the auto-trace option works. One of my coworkers had a PCX bit-image file handy. It was part of a set of slides for lecturers to use instead of scribbling on a whiteboard. The file

continued



MKS Toolkit™

UNIX™ Tools on DOS or OS/2

Programming today means you must work within more than one environment. A diverse range of hardware is now a fact of life. With the MKS Toolkit, you can enjoy the best of DOS or OS/2 and UNIX environments. The MKS Toolkit offers both experts and novices the purest form of UNIX utilities that the DOS or OS/2 environment allows.

Reduce Keyboard Shock

With our proprietary code, the MKS Toolkit offers you more than 140 UNIX System V.3-compatible tools for DOS or OS/2. With the MKS Toolkit, your computer or clone becomes a comfortable environment for shells, string matching, editing, file manipulation, and more. Productivity increases because all the familiar commands are at your fingertips.

Site Licenses

The MKS Toolkit reflects its users' needs. Organizations such as AT&T, H-P, ITT, and NCR - all heavily committed to the UNIX system - use the MKS Toolkit to create a standard operating environment. Universities, including UCLA, use the MKS Toolkit to enrich personal research computing environments and double the bandwidth of their PC teaching labs. The National Institute of Standards and Technology fulfills diverse needs by using the MKS Toolkit as standard operating environment for experts and as a POSIX-conforming training tool for neophytes.

Interconnectivity

The MKS Toolkit provides two types of valuable interconnectivity. First, it interacts well on most standard PC and PS/2 networks. Combined with Novell Netware™, the most popular LAN for

PCs, the MKS Toolkit creates a UNIX time sharing system in DOS or OS/2 organizations. UNIX shops can now hook up all their PCs using PC-NFS™ and the MKS Toolkit, enabling you to use a PC as a UNIX workstation and off-load your mini or mainframe machine. The second level of interconnectivity is created by the MKS Toolkit's ability to recognize common UNIX file formats on DOS or OS/2 and to make DOS or OS/2 file formats available on UNIX systems.

POSIX-Conforming Tools

MKS is an active participant on the POSIX 1003 standards committee. This involvement reflects MKS' commitment to tracking the shells and utilities standard to the fullest extent possible under DOS or OS/2. Apart from multi-tasking and constraints on file names under DOS or OS/2, the MKS Toolkit follows the POSIX standard. MKS achieves this by building the underlying POSIX system on DOS or OS/2 before moving utilities.

Cost-effective Learning Tool

If your organization is committed to moving into the UNIX environment, then the MKS Toolkit is the perfect learning path. DOS or OS/2 users retain the familiar world of their PC keyboard and programs and move effortlessly to a UNIX environment on their desktop. Exposure to new commands and functionality now becomes an integral part of the novice's working day. UNIX solutions are easily available and the DOS or OS/2 world is but a keystroke away.

MKS Programming Platform

The MKS Toolkit is the vital core of the programming platform created by MKS software. In addition to the MKS

Toolkit, it is now possible to have:

- MKS RCS™ (Revision Control System)
- MKS Make™ (automated program builder)
- MKS LEX&YACC™ (compiler construction tools)
- MKS SQPS™ (enhanced Documentor's Workbench™)

Addictive Software!

The MKS Toolkit offers you power and diversity. Here is a complete list of commands you receive in the package:

alias	ed	let	sort
awk	env	line	split
banner	eval	login	strings
basename	ex	ls	strip
bdiff	exec	mkdir	sum
break	exit	more	switch
c	expand	mv	sync
cal	export	nl	tail
case	expr	nm	tee
cat	false	od	test
cd	fc	pack	[
chdir	fg	passwd	time
chmod	file	paste	times
cmp	find	pcat	touch
:(colon)	fmt	pg	tr
comm	fold	pr	trap
compress	for	print	true
continue	function	prof	ty
cp	getopt	ps	type
cpio	glob	pwd	typeset
crypt	grep	r	ulimit
ctags	fgrep	read	unalias
cut	grep	readonly	uname
date	gres	return	uncompress
dd	hash	rev	unexpand
deroff	head	rm	uniq
dev	help	rmdir	unpack
df	history	rsh	unset
diff	if	sed	unstrip
diff3	init	set	until
diffh	integer	sh	vi
dirname	jobs	shift	wc
.(dot)	join	size	whence
du	kill	sleep	which
echo	lc	spell	while
			who

No wonder our users call it addictive software!

System Requirements:

The MKS Toolkit works on IBM PC, XT, AT, PS/2 and compatible machines under DOS 2.1 and higher or under OS/2. A hard disk is recommended for improved performance and convenience.

Order Information

Price: \$199 for MKS Toolkit, \$495 for OS/2.
30-day money-back guarantee

1-800-265-2797 (continental U.S. only)

1-519-884-2251 (outside continental U.S.)

1-519-884-8861 (FAX)

Ask for Department BY



35 King Street North
 Waterloo, Ontario N2J 2W9 Canada

contents were fairly simple: three ellipses with a couple of words in each and arrows drawn between them. However, when Corel had completed its auto-trace, the program had transformed the bit image into something that looked as if it had been hand-drawn on a whiteboard. Even the straightest of straight arrows had a certain artistic flair. Changing auto-trace preferences to track the objects either more or less closely had no noticeable effect on the drawing.

The artistic effect occurs because Corel's auto-trace is set up mainly for freehand or scanned images—not for straight lines and regular curves. The tracing algorithm is supposed to capture accurately about 85 percent of the outline. Results are predictable only in the sense that the identical image in different locations is likely to be traced identically.

There was a certain charm to Corel's version of the bit-mapped drawing, par-

ticularly after the proportions were changed and the images colored—so much so, in fact, that I decided the drawing was worth saving. However, when I tried to save the file, up popped "System error. Cannot read from drive C:" Neither of the two button choices, Retry or Cancel, had any effect, nor was I able to exit to either the Windows environment or DOS. Apparently, some action in manipulating the auto-traced file caused a hard disk failure. Fortunately, this was only a transient problem that did not recur after the computer was turned off and turned back on.

Corel Draw can import and export its own CDR format files, PCX and TIFF bit-image files, import Adobe Illustrator ART and Lotus PIC object files, and also export EPSF and Windows Metafile. Surprisingly, for a program that requires the Microsoft Windows environment, it cannot import a Windows file.

WordPerfect 5.0 could read and display the exported files. I would not pay any attention to the manual's suggestion that you select the smallest file size to conserve space. Instead, pick the highest resolution to reproduce the image with any kind of accuracy. And when you want the printed image to fit on one physical page, either select Fit to Page or enlarge the page size. There are invisible margins that the printable page area doesn't tell you about.

Not a Clear Picture

Corel Draw has the potential to become the program of choice for producing professional-quality graphics art for all kinds of people with varying degrees of artistic talent and computer ability. Commands are intuitive, the program is easy to learn, and it is packed with features. But there are a number of problems. Some are mere annoyances, like sometimes locking up the system after a drawing is printed. Some are more significant, like occasionally printing descenders under the wrong letters. And some, like an error indicating a hard disk failure, may portend more substantial problems.

Would I continue to use Corel Draw? Yes, I would. Although the current version is far from perfect, it's more than just pretty good. As a matter of fact, I admit that I've become addicted to Corel Draw. ■

Sue Rosenberg is a consultant at James Martin Associates in Reston, Virginia. Her secret ambition is to become a typeface designer. Sue can be reached on BIX as "suer."

PC Voice Mail, now only \$199.

For an ear-opening telephone demo call:
1-800-6-WATSON Ext. 133

Now get a *combined* PC-based voice mail, data modem, and telephone answering system—from only \$199. With Watson, you'll *profitably* improve your business communications with clients, colleagues, sales and service reps, field staff, vendors.

Benefits Of A \$20,000+ Voice Messaging System Or "Personal Receptionist" For As Low As \$199

Look at all of these advanced features:

Voice Mail—Watson's automatic telephone answering lets callers leave and receive messages of any length 24 hours a day, 7 days a week. Ends "telephone tag" with clients and colleagues. Forwards messages automatically to mobile phones and pagers. Retrieve messages from any touchtone phone—even a car phone. Never miss an important call! And Watson provides "big system" professional sound quality!

Up To 750 Private "Mailboxes"—Give up to 750 of your colleagues or clients an individual, confidential "voice mailbox." Use them to receive private messages or record special messages for individual callers.

Electronic Telephone Book—In one keystroke, access any of up to 750 telephone numbers, then use automatic dialing and re-dialing if busy. Store key information on contacts and get it immediately when you need it.

Hayes-Compatible Data Modem—Comes complete with 1200 BPS Hayes-compati-

ble modem (or optional 2400 BPS modem). Transfer your data files and access Telex, E-Mail, Dow Jones, or other public databases.

Simultaneously Run Popular Business Programs—Run programs such as Lotus 1-2-3 while Watson records or delivers messages.

Plus—Watson efficiently guides callers through the options they have in leaving messages... Delivers special pre-recorded messages to individuals at pre-determined times... Automatically forwards messages to other telephone lines or numbers... Provides an electronic calendar with automatic alarms and telephone notification.

30-Day Risk-Free Trial Installation

Try Watson for 30 days. If you aren't 100% satisfied, send it back for a prompt and full refund. No questions asked.

Demo Hotline

For a telephone demo call 1-800-6-WATSON EXT. 133 (in MA 1-508-651-2186 EXT. 133). Tell us EXT. 133 and receive a *free* five pack of diskettes if you purchase.

Order Hotline

To order Watson call 1-800-533-6120 EXT. 133 (in MA 1-508-655-6066 EXT. 133). Tell us EXT. 133 and receive a *free* five pack of diskettes with purchase. Price: \$199. For optional 2400 BPS modem add \$100. MasterCard, VISA, and American Express accepted. Credit card or check must accompany order.



Watson®

Natural MicroSystems Corporation, 8 Erie Drive, Natick, MA 01760-1313

OVER 30,000 SOLD

June 1989

BYTE

Bonus All-Mac Issue

Macintosh Special Edition



Mac vs. NeXT
SuperPaint
Swivel 3D

Pushing Standard File to the Limit
The Z88 as a Mac Accessory
Plus More



Don't take chances. Ask for Seagate.

 **Seagate**
The first name in disc drives

BYTE

Macintosh Special Edition

Short Takes 219

Pushing Standard File to the Limit 225

The Mac Interface: Showing Its Age 235

A Portable Companion for the Macintosh 241

Mixed Blessings 249

EDITORIAL

A Source of Mac Information

BIX is different
from BYTE—and
yet the same

BIX (the BYTE Information Exchange) is an on-line service where people come to ask and answer questions about using their computers. All sorts of computers, to be sure, but if you're reading this part of the magazine, I'm here to tell you that there's definitely an electronic watering hole for Macintosh users.

A Change for the Better

If you're one of those who uses BIX regularly for Mac information, you're probably aware that the macintosh conference has been closed for a few months. However, that's because it has been replaced by something better: eight Mac-related conferences that are collectively termed the Macintosh Exchange.

Although the name may have changed, the asking (and answering) of technical questions goes on. It wouldn't be BYTE-ish if it didn't, right? Not to mention the massive diatribes on the Great Mac Questions of Today by people who are intimately involved with those same questions. (Is it better to use System 6.0.2 or

6.0.3? Should I buy an ImageWriter LQ Plus?) Even people from Apple come to BIX to lend expertise and advice.

But unless you telecommunciate via modem, you miss the rich two-way experience that happens here. Worse, you miss the ability to subscribe to an interactive BYTE: up-to-the-minute news information, plus timely reviews of products and services when you need them. For example, you can get tips on how to lay out your first-ever report perfectly on the LaserWriter, the very same day you ask for help. The power of BIX is that you get answers to *your* particular question, when you need it. Also, the Mac listings area has lots of public domain and shareware applications, desk accessories, and INITs to help you use your Mac more efficiently.

Come Join Us

BIX is for rank beginners as well as intermediate folk. Anyone interested in the Mac will find something of interest in the Macintosh Exchange. Because it's on BIX, it has all the resources and people of BYTE available to it. Because it's about the Mac, you can use it. I hope to see you on-line soon.

—*Laurence H. Loeb*
Editor, the Macintosh Exchange
(BIX name "lloeb")

PSpice

Mixed Mode Simulation Now Available on the Macintosh II



Since its introduction just over five years ago, MicroSim's PSpice has sold more copies than all other SPICE programs combined. In addition to running on the IBM PC family, including the new PS/2 and the Compaq 386, the Sun and Apollo workstations and the VAX/VMS family, PSpice is also available on Apple's Macintosh II.

All these features which have made PSpice so popular are available:

- Standard parts libraries for diodes, bipolar transistors, power MOSFET's, opamps, optocouplers, voltage comparators, and transformer cores.
- GaAs MESFET devices.
- Non-linear transformer devices modeling saturation, hysteresis, and eddy current losses.
- Ideal switches for use with, for example, power supply and switched capacitor circuit designs.

In addition, all these PSpice options are available on the Macintosh:

- Monte Carlo, Sensitivity, and Worst Case analyses calculate the effect of parameter tolerances on circuit performance.
- The Probe "software oscilloscope", provides interactive viewing of simulation results.
- The Parts parameter extraction program, allows you to extract a device's model parameters from data sheet information.
- Digital Simulation, allows you to simulate mixed analog/digital circuits, including feedback loops between analog and digital. A library of over 600 common TTL parts is included.

Each copy of PSpice comes with our extensive product support. Our technical staff has over 100 years of experience in CAD/CAE, and our software is supported by the engineers who wrote it.

For our free information packet, including our PSpice demo program for the Mac, call us at (714) 770-3022 or toll free (800) 826-8603. Find out for yourself why PSpice is the standard in circuit simulation.

Circle M14 on Reader Service Card (DEALERS: M15)



MicroSim Corporation

20 Fairbanks • Irvine, CA 92718 USA • Telex 265154 SPICE U

SHORT TAKES

BYTE editors' hands-on views of new products

SuperPaint 2.0

Swivel 3D

Industrial-Strength Graphics

The original version of Silicon Beach Software's SuperPaint merged the dissimilar strengths of object drawing and bit painting by letting you compose an illustration in two layers. You used a draw layer to manipulate objects (e.g., arcs and circles) that print with PostScript's precision (like MacDraw). A paint layer let you work with bit-mapped images (like MacPaint). The newly introduced **SuperPaint 2.0** follows this two-layer concept while correcting problems the earlier version had with the Macintosh II family's color displays and adding significant new features.

Here are a few of the new features in the draw layer: a freehand Bézier drawing tool, the ability to draw and print hairlines, and a set of gray patterns that correspond to PostScript halftones when these patterns are output on a laser printer. The paint layer has the usual MacPaint-style tools. However, with the airbrush tool, you can modify not only the shape of the spray area and its size, but you can also alter the flow rate, pattern, and dot size of the digital "ink."

SuperPaint 2.0 supports only the eight fixed QuickDraw colors. SuperPaint's function is not to serve as a color painting application, but as a tool to generate industrial-strength business and technical graphics where color is

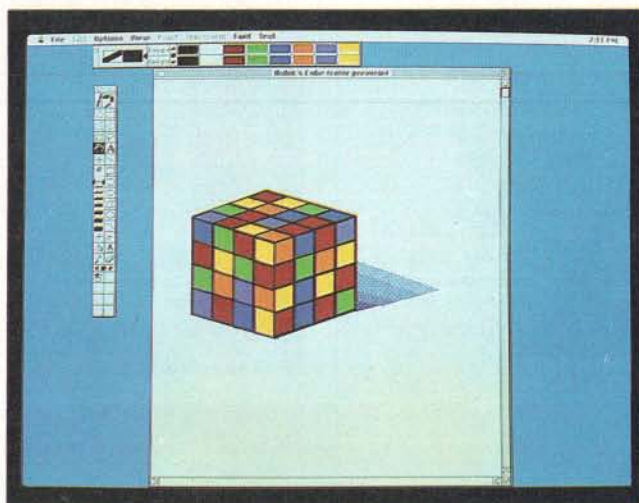

THE FACTS

SuperPaint 2.0
\$199

Requirements:
Mac Plus, SE, SE/30,
or II with 1 megabyte of
RAM and System
6.0.2/Finder 6.1
or higher.

Silicon Beach Software,
Inc.
9770 Carroll Center
Rd., Suite J
San Diego, CA 92126
(619) 695-6956
Inquiry M200.

used sparingly, if at all. All editing work is done strictly in black and white, but a color preview selection lets you examine your handiwork in color on a Mac that supports it.

An auto-trace function traces the outlines of bit-mapped images in the paint layer, rendering a duplicate of the image in the draw layer as sets of polygons or Bézier curves. You might use this in a situation where you would scan a technical drawing, auto-trace it in SuperPaint, and edit the drawing for use as

a figure in a technical manual.

The most intriguing part of SuperPaint 2.0 is its plug-in tools. These are files, which contain executable code, that appear as tools or as menu selections inside the SuperPaint application. For example, the spiral tool draws spirals, a quill tool closely mimics the actions of an ink quill, a bubble tool sketches bubbles of varying sizes, and another tool draws three-dimensional boxes—with shading, if it's needed—with the stroke of the mouse. The plug-in tools show

SuperPaint's real potential, because the application itself can be expanded as Silicon Beach Software or other vendors supply plug-in modules that have more complex features.

I tried SuperPaint 2.0 on a Mac Plus, a Mac II with a SuperMac 19-inch color monitor, and a Mac SE/30. The tools behaved much like those found in MacPaint and MacDraw: the sort of consistent behavior you demand of Mac applications. I scanned some pen-and-ink drawings with a Howtek Scanmaster into MacPaint documents (auto-trace doesn't work on PICT files). SuperPaint's auto-trace function worked reliably, with no bombs. It's a godsend for simple art. For more complicated images, however, you'll probably spend more time than it's worth tweaking curves trying to finish up the image.

If you want a drawing application that's a lot more capable than MacPaint but don't need full-blown color, SuperPaint looks like the one to buy. If you use MacDraw to crank out images daily for trade journals or newspapers, you should check it out. It has a number of features that make it handy for such work, particularly the auto-trace function. I wish it had a trace function (as Illustrator does) for manually tracing over complex artwork. Perhaps somebody might devise a plug-in tool to do just that.

—Tom Thompson

Mac Modeling in 3-D

Swivel 3D for the Macintosh is an attempt to extend the two-dimensional world of object-oriented drawing programs like MacDraw into three-dimensional mod-

eling, and it's a successful attempt. VPL Research wrote the program in MacForth to satisfy its own modeling needs for the DataGlove it produces (the DataGlove, which is used

by NASA when it is doing research in computer-generated simulations, is a pointing/grasping device that you wear on your hand and use to com-

continued

"VAX-to-the-Macs" Specialists—With A Respected Family Tree!

White Pine Software offers a complete family of products for total two-way Macintosh™/VAX™ communication: text, graphics, file transfers and program access.

① Mac240™

Turn your Mac into a VT240 with our acclaimed DEC™ terminal emulator. White Pine's "VT240 emulator stands among the best"—says Digital News.

② Mac241™

All the functions of Mac240 PLUS COLOR.

③ Mac220™

Full featured VT220™ emulation with expanded text and special character capabilities.

④ VMacS™

Share Macintosh text, data and program files among users.

⑤ Reggie™

Convert MacPaint™, MacDraw™, and Clipboard™ images into ReGIS™ or SIXEL™ formats.



**WHITE PINE
SOFTWARE**

**CALL (603) 886-9050
for your desktop communication solutions.**

Mac240, VMacs, and Reggie are trademarks of White Pine Software, Inc., DEC, VT, VAX, are trademarks of Digital Equipment Corporation; MacDraw, MacPaint, and Clipboard are trademarks of Apple Computer, Inc.; Macintosh is a trademark licensed to Apple Computer, Inc.

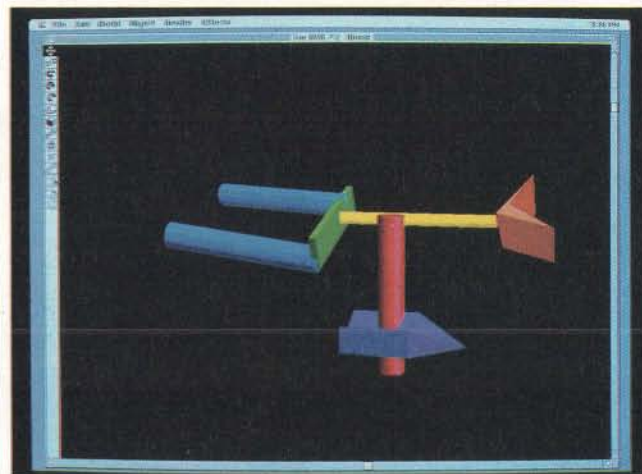

THE FACTS

Swivel 3D
\$395

Requirements:
Mac with at least
1 megabyte of RAM,
System 1.0, and Finder 6.1.

123 Townsend St.,
Suite 310
San Francisco, CA
94107
(415) 543-3848
Inquiry M201.

YOU SAVE MONEY With Guaranteed 100% Error-Free Sony 3.5" Diskettes

Sony Brand DS 1.0 MB 50/Pack 89¢ ea.

Sony Brand DS 1.0 MB

10/Box \$1.24 ea.

Sony Brand DSHD 2.0 MB

10/Box \$2.99 ea.



Save On Proven Printer Supplies Too!

Canon Brand EP Toner Cartridge Series I

For Apple Laserwriter/Apple Laserwriter II

\$79.95 ea.

Canon Brand EP-S Toner Cartridge Series II

For Apple Laserwriter II

\$79.95 ea.

Apple Imagewriter Ribbons (Black)

\$2.25 ea.

This Offer Expires July 31, 1989



CALL TOLL FREE: 1-800-258-0028

**ATTENTION MAC USERS: Ask About Our Unique
Catalog-On-Disk...Extra Special Savings on Supplies**

FREE CATALOG! Complete Line of Quality Supplies For Your Computer.

Foreign Inquiries Invited.

Minimum Order \$25.00. Prices Subject to Change. S&H: F.O.B. Grand Rapids, MI.



Precision Data Products™

P.O. Box 8367 • Grand Rapids, MI 49518 USA

MI: 800-632-2468 • 313-645-4980

616-452-3457 • FAX: 616-452-4914



communicate with the computer).

The key to Swivel 3D is the way it can link the movement of different objects created in the program to each other. These movement links can be linear (like a drawer constrained to only straight-line x- and y-axis movement), ball and socket (free to rotate but not to translate around one of the endpoints), and free (any movement is OK). This feature is not found in any other program that we're aware of, and it works well for the simulation of three-dimensional movement. Without this sort of linking, the program would simply be another sophisticated drawing program. With these links, movement simulation becomes possible.

It's easy to create objects with the package's tools and the four standard isometric views of the editor. Rendering functions let you develop wireframe models and also alter contours and shading (with an adjustable light source). The speed of the screen redraws on the Mac Plus, with full rendering switched on, is an order of magnitude faster than any

similar program we've tried; such redraws are usually so slow as to be annoying. It looks like the product's programmers did some tight coding here.

Another important feature in Swivel 3D is its "tweening" capability. You specify a start and a stop, and the machine can then generate intermediate views. This works well, but a player program to use these animations (much like the one Silicon Beach Software included with Super 3D) would be a welcome addition. The intermediate views can be saved in MacPaint format.

Two versions of the program come in the box. One works on a Mac with 1 megabyte of RAM or more; the other works on a Mac with 2 megabytes or more. They differ only in the size of memory swaps used internally. We used the higher-memory-size program, and it ran nicely.

This is a unique and well-crafted program that should find its way into the libraries of all serious modelers.

—D. Barker and
Laurence H. Loeb ■

APPLE TURNS 030.

The time was ripe.

Apple® was planning their most advanced Macintosh® SE and Macintosh II computers ever. So it was only natural that they turn to Motorola's 68030 32-bit microprocessor.

After all, Motorola's 68000 family has been instrumental in helping Apple develop its consistent, intuitive graphics workstyle, which has revolutionized the way people communicate with computers. And now, the 030 is making that workstyle even more versatile and powerful than ever.

The new Macintosh SE/30, based on a 16MHz 030 along with Motorola's 68882 math coprocessor, delivers up to 4x the performance, and in floating point calculations can deliver up to 100x the performance, of the Macintosh SE. What's more, it features a new expansion slot called,

astutely enough, "030 Direct Slot," which allows third parties to extend the Macintosh SE/30's capabilities with a whole range of expansion cards.

The Macintosh IIx also uses the 68030 and 68882 to great advantage. In fact, 030 firsts like on-chip data and instruction caches and built-in Page Memory Management Unit streamline the Macintosh IIx architecture, and enable every

Macintosh IIx to run Apple's A/UX® advanced multitasking operating system.

So if you want to build your most advanced system ever, put an 030 at its core. For free benchmarks and more information, call or write your local Motorola sales office.

It could be the smartest pick you ever make.



MOTOROLA



Aside from being a tad easier to install than a satellite, the Hayes Smartmodem 2400M™ for the Macintosh® II and Smartcom II® for the Apple® Macintosh make up the most advanced communications system you can put inside a Mac®.

With this modem and software package, you can set up an extensive Macintosh work group system through a feature called HayesConnect.™

HayesConnect™ allows any Mac access to the Smartmodem 2400M across an AppleTalk® Network.

Which means all Macintosh computers on the Network will be able to communicate with or without a modem of their own. This makes for extremely efficient office communications.

THE ONLY COMMUNICATIONS SYSTEM MORE ADVANCED THAN OURS WON'T FIT INSIDE YOUR MAC.

To make them even more efficient, the system offers Smartcom II for the Macintosh. It's the only software designed to take full advantage of the power and graphics capabilities of all of the computers in the Macintosh family. For example, you can program your own on-screen buttons to create a personalized user interface. You also get features like moveable icons, custom color selection and full support of ImageWriter® and LaserWriter® for incredible graphics. You can even run the system unattended using an Autopilot feature. Of course, there is much more you can do with a few simple clicks on standard, easily identifiable icons.

By now it's probably clear that whether they're just used with the Macintosh II or shared by Mac computers on an AppleTalk Network, the Smartmodem 2400M and Smartcom II make a communications system that can't be beaten. At least not by anything on this planet.



Hayes®

For your nearest Hayes Advanced Systems Dealer, call **800-635-1225**. Hayes Microcomputer Products, Inc., P.O. Box 105203, Atlanta, GA 30348.

Apple, Macintosh, Mac, ImageWriter, LaserWriter and AppleTalk are registered trademarks of Apple Computer, Inc. © 1989 Hayes Microcomputer Products, Inc.

Macintosh® In Business

NEW 256 Page Guidebook - Free

The MicroGroup offers a balanced line of high technology and general business products resulting from solving our own productivity and production problems where outside solutions were unavailable. Our completely new Sping'89 Guidebook was produced on Macintosh - of course!

Macintosh® In Manufacturing

We believe office and factory automation are mandatory components of customer service. We also recognize the necessity of applying automation as the only solution to our continued growth and profits. The most important lesson we learned is that simplicity and easy-of-use are the only considerations in developing any automation system.

Patented 1stKEY™ Database Software

Regardless of your size, 1stKEY can produce just about anything that you will ever need in a business database system-FAST. 1stKEY can provide MIS the productivity of relational workload distribution and easy to use reporting across all platforms. Anyone can quickly design systems that can easily interact with other systems - even remote sites. 1stKEY features powerful patented FUZZY Triage FIND™ for performing inexact weighted searches across four fields.

MacBOT® Robotic Systems

The MacBOT-8 data acquisition and control system was created as a flexible tool to apply the power of Macintosh and HyperCard® to your everyday automation requirements - "Personal Automation". MacBOT robots and robotic components can be applied to push-pull and rotary motions and multiple axis devices that look and like their larger counterparts. Complete weighing systems available.

the MicroGroup® Products & Services Specifiers Guidebook

Abridged Pocket Version

© 1988 By the MicroGroup, Inc.

Precision Metals ALL-TUBE® Corporation

Stainless Steel Tubing
Luer and Tube Fittings
Precision Fabrication
Metalworking Tools



Office Automation 1stDESK® Systems, Inc.

Information
Management Systems
for the Macintosh®



Factory Automation MacMOTION, Incorporated

Data Acquisition
Motion Control
Desktop Robots



7 Industrial Park Road Medway, MA 02053

1-800-255-8823

Trademarks: Macintosh; Apple Computer, Inc.; MicroGroup; MicroGroup, Inc.; 1stDESK, 1stKEY; 1stDESK Systems, Inc.; MacBOT; MacMOTION, Inc.

Our 256 page Guidebook is also in the >>>THOMCAT<<< Thomas Register Catalog File

Pushing Standard File to the Limit

Jan Eugenides

*You can modify
Standard File
to customize
file-selection menus*

I began my computing career with an Apple II+. Filenames were short, and DOS 3.3 had no subdirectories. Entering a filename was no big deal. Then came ProDOS. I remember having to type long path names just to open a deeply nested file. One typo, and you had to type it all again. I remember thinking there had to be a better way.

The Standard File Package is the Macintosh's idea of a better way. Standard File is part of the Macintosh System software. It is designed to give the user an easy way to select a file—by displaying a list of filenames from which to choose. Standard File displays the contents of one directory (or folder) at a time in a scrollable filename list. You need to type the filename only once, when creating the file. Thereafter, you simply select it from the list. Point and click. No typos.

There are two regular Standard File dialogues, one for saving files (the SFPutFile dialogue) and one for choosing files (the SFGGetFile dialogue). They behave similarly and look very much alike (see figure 1). Each displays a list of folders and files, buttons for switching between drives and ejecting disks, and buttons for opening folders or files and for canceling the dialogue. The SFPutFile dialogue also has a field of editable text for entering a filename.

From the user's point of view, it's an easy system to use. All Macintosh applications use Standard File, so you learn it once, and that's it.

From a programmer's point of view, things are not quite so simple. For some applications, the regular dialogues are sufficient. Then the programming is easy. For other applications, however, Standard File falls short in many areas.

For example, Standard File provides almost no visual cues as to the nature of the files. The user can't see the files' icons and has no clue to their contents other than their names. He or she can tell if they are documents or applications, but that's about it. On a graphics-based sys-

tem like the Mac, that's almost a crime. And if you, as the programmer, need to let the user select file formats or other file attributes, you can't do it with the standard controls.

The designers of Standard File made it extensible, but the flow of control is somewhat convoluted. Understanding comes slowly, but the system is remarkably powerful once you have fathomed it. With a little work, it'll do just about anything.

In the course of my work, I have spent many hours working with Standard File. In the process, I've developed some useful techniques for modifying its behavior, and I'd like to share some of them with you. *Inside Macintosh* and *Apple Tech Notes* make mention of some of these techniques; however, neither of those sources is always as clear as it could be. I figure there's nothing clearer than a good working example, so I've written a demonstration program to accompany this article. The other techniques discussed here are my own and haven't appeared anywhere else.

Due to space limitations, I'm not going to describe the normal functioning of Standard File in any detail; I'll assume you already understand how to use the regular Standard File calls. If you don't, I suggest you read *Inside Macintosh*, volume 1, chapter 20.

Adding New Controls

The two regular Standard File dialogues are stored as resource templates in the System file. The SFGGetFile dialogue is stored as DLOG -4000, and the SFPutFile dialogue as DLOG -3999. Each DLOG has an associated dialogue item list (DITL) with the same ID number.

Two functions display and handle the Standard File dialogues. They are declared as follows (in C):

```
pascal void SFGETFILE  
(where, prompt, fileFilter,
```

continued

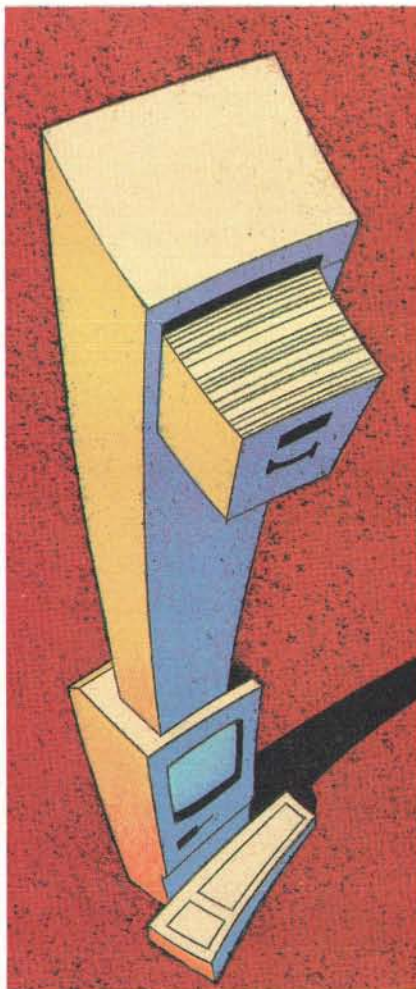

```

numTypes, typeList, dlgHook,
reply)
Point      where;
Str255     *prompt;
ProcPtr    fileFilter;
short      numTypes;
SFTypeList *typeList;
ProcPtr    dlgHook;
SFReply    *reply;
    
```

```

pascal void SFPUTFILE(where,
prompt, origName, dlgHook,
reply)
Point      where;
Str255     *prompt,
           *origName;
ProcPtr    dlgHook;
SFReply    *reply;
    
```

The point where determines where on the screen the dialogue is displayed. The string prompt is displayed above the editable filename in the SFPutFile dialogue (it is not displayed anywhere in the SFGetFile dialogue). The ProcPtr (procedure pointer) dlgHook points to a procedure, which you provide, that handles the dialogue's controls (you would pass NULL to use the default handler), and the ProcPtr fileFilter points to a procedure that determines which files are displayed in the list. The variables numTypes and typeList provide a simple way of limiting the files displayed to certain types.

The SFReply record is filled in by the Standard File routines and contains all

the information you need to access a file. It is declared like this:

```

typedef struct SFReply {
Boolean good;
/*whether the dialogue was
canceled or not*/
Boolean copy;
/*unused*/
OSType fType;
/*the file's type*/
short vRefNum;
/*the directory reference
number*/
short version;
/*the version, usually
ignored*/
String(63) fName;
/*the name of the file,
preceded by a length byte*/
} SFReply;
    
```

There are two ways to add controls to the Standard File dialogues. One way is to provide alternate DLOGs and DITLs that have the same ID numbers as the regular ones. If these are put into the resource fork of your application, they will be used in place of the regular ones whenever you call the Standard File routines.

The other way to add controls is, again, to provide your own DLOGs and DITLs, but then pass the ID numbers of these templates directly to Standard File, using these two alternate calls:

```

pascal void SFPGETFILE(where,
prompt, fileFilter, numTypes,
typeList, dlgHook, reply,
dlgID, filterProc)
Point      where;
Str255     *prompt;
ProcPtr    fileFilter;
short      numTypes;
SFTypeList *typeList;
ProcPtr    dlgHook;
SFReply    *reply;
short      dlgID;
ProcPtr    filterProc;

pascal void SFPPUTFILE(where,
prompt, origName, dlgHook,
reply, dlgID, filterProc)
Point      where;
Str255     *prompt,
           *origName;
ProcPtr    dlgHook;
SFReply    *reply;
short      dlgID;
ProcPtr    filterProc;
    
```

Both SFPGetFile and SFPPutFile provide you with an additional hook, the filterProc. It allows you to intercept

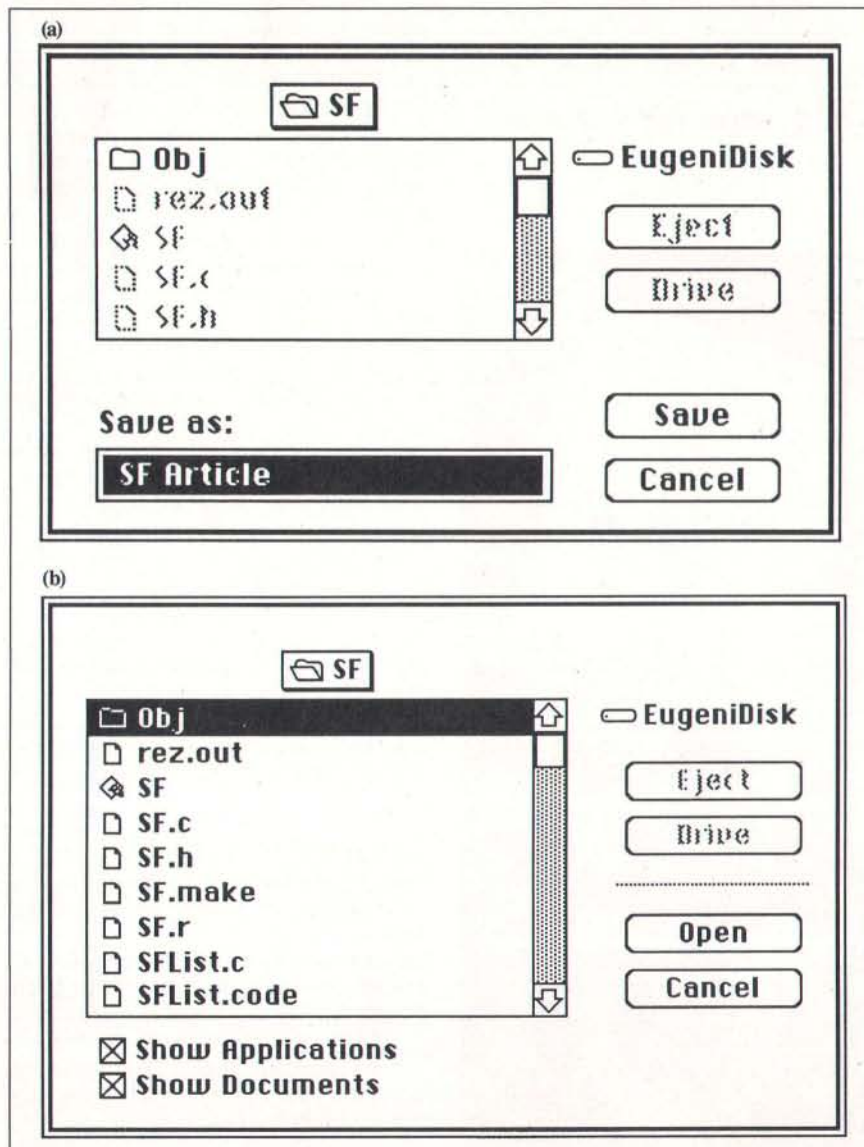

Figure 1: The two regular Standard File dialogues: (a) SFPutFile, and (b) SFGetFile, with file filter checkboxes.

events, a capability that can be very useful indeed.

The only stipulation when creating your own dialogues is that any new controls must be in addition to the regular controls. You cannot remove or renumber any of the standard controls. You can, however, reposition them or change their titles.

Thus, the minimum you must do to add controls is to create your own dialogue templates and write a `dlgHook` procedure to handle them. The `dlgHook` is declared as follows:

```
pascal short dlgHook(item,dlg)
short      item;
/*the item that was clicked
on*/
DialogPtr dlg;
/*the dialogue pointer*/
```

It must return an item number (not necessarily the one it was passed). This feature can let you change a click on one of your controls to a click on a standard control. But most often, you'll simply pass `item` on unchanged, doing nothing unless one of your extra controls is clicked on.

In the demonstration program that accompanies this article, I've added two checkboxes to the `SFGetFile` dialogue (see figure 1b).

Four Quick Tricks

Here are four dialogue-hook tricks that can make your life easier. First, before Standard File displays the dialogue, it calls your `dlgHook` with an item of -1. This lets you do any necessary initialization before the dialogue appears on the screen. If you need to change the titles of any of the buttons before they appear, this is the time to do it. If you have radio buttons or checkboxes in your dialogue, this is the time to turn them on or off.

Second, returning 101 for the item number causes Standard File to redisplay the list of files. This can be useful for implementing special controls that specify what types of files to display. When the control is clicked on, you can set up your file filter and then return 101 to redisplay the list with the new filter. The demonstration program does this.

Third, the item #102 is passed to your `dlgHook` whenever the pop-up menu that displays the list of directories is clicked on. Usually you don't need to know this, but for the graphical version shown in the demonstration program, it's essential.

Finally, there is a way to determine which folder on which volume Standard File will display. There are two low-

continued

Hey Mac, Nisus™ Is Not Just Another Word Processor.



Here's why.

Want to draw a picture without ever leaving the program? *Easy.*

Want to wrap text all the way around it or let the text flow right

through? *Easy.*

Want to see it all in glorious color?

Easy.

Need to find a particular word or phrase by searching

through all files, open or not?

Easy.

Need to use our superior dictionary or thesaurus?

Easy.

Want to undo what you just did,

or any number of things you did

before? Unlimited Undos. *Easy.*

Want to use the fastest word processor on the market? *Easy.*

Line numbers? Envelopes? Auto-save? Column selection? Adjustable

page preview?

Ten clipboards that can be edited and

printed? Your favorite page layout

ready when you open a new file?

Easy.

It's all easy when you have Nisus.

Ask your favorite dealer.



Nisus is a trademark of Paragon Concepts, Inc.



Simulate with Extend™

Model electronic systems, cash flow, factory production, computer networks, neural response, signal processing, earthquakes, process control, material handling...

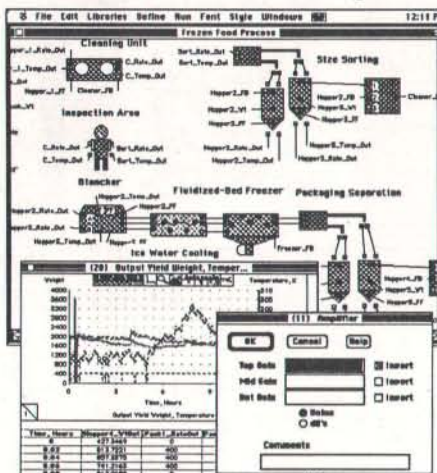

"... create some dazzling simulations without the pain normally associated with simulation programming. For my money, Extend lives up to its name."

- Don Crabb, Byte Dec. '88

Extend's unique features include:

- Continuous and Discrete Event
- Block diagram, library based
- Built-in programming language
- Custom dialog boxes and icons
- More than 150 built-in functions
- User defined functions
- File, Serial, Driver I/O
- Engineering libraries included
- \$495 for the Mac Plus, SE, II, Ix

Now Shipping Version 1.1!

Imagine That, Inc.

(408) 365-0305

7109 Via Carmela, San Jose CA 95139

Imagine That! and Extend are trademarks of Imagine That, Inc.

PUSHING STANDARD FILE TO THE LIMIT

memory globals that control this: SF-SaveDisk and CurDirStore. To display a particular directory, put the negative of the volume reference number in SFSaveDisk and put the directory ID (the unique directory ID number, not the working directory reference number) in CurDirStore before calling Standard File. To change directories in midstream, set the globals and then pass the item 101 back from your dlgHook to redisplay the list. (This works only in System 6.0 or higher; earlier Systems will not change direc-

checkbox is unchecked, applications disappear from the display. When the Show Documents checkbox is unchecked, documents go away. When they are both unchecked, only folders appear.

Of course, a file filter need not check file type but can examine any file attribute. You can write a filter that displays only files with the word *Fred* in their names or that displays only files created after a certain date. It's up to you.

How to Intercept and Modify Events

For really special needs, the filterProc gives you control over the events that the dialogue encounters. All events, including both user events, such as key presses and mouse-clicks, and system events, such as window updates, are passed through the filterProc before Standard File handles them. This allows you to intercept them and handle them your own way. You can even modify them before passing them along. A filterProc also has access to the item that has been clicked on. This means, for example, that you can change a certain key-stroke into a click on a particular control.

A filterProc is declared like this:

```
pascal Boolean ourGetFilter
    (dpeek,ep,itemhit)
DialogPeek    dpeek;
EventRecord   *ep;
short         *itemhit;
```

The event record, pointed to by ep, contains information about the current event. The value returned in itemhit is interpreted by Standard File as a click on that item.

The demonstration program shows several interesting things that can be done in the filterProc. For example, null events are transformed into a click on item #45 if a disk has been inserted or ejected. There is no item #45 in the dialogue, but the dialogue hook is written to treat a click on item #45 as a signal to update the graphical list. This is how the graphical list stays synchronized with the Standard File display.

If the Return or Enter key is pressed, the filterProc translates the key press into a click on item #12, which is the "fake" Open button.

Finally, when update events are encountered, the graphical list is redrawn to ensure the proper appearance of the dialogue.

Overriding the Normal Controls

Take a close look at figure 2, the sample graphical file list. It looks like a regular

continued

Sandard
File will crash if
the standard userItems
are not there.

ories.) If you need to display the root (uppermost) directory, use 2 for CurDirStore. You can also read from these globals to determine which directory is currently being displayed.

Controlling the Display of Files

File filters let you control which files are displayed in the SFGetFile list. A filter is declared like this:

```
pascal Boolean ourFileFilter
    (ParmBlkPtr pb);
```

The filter is called once for each file in the directory, just before the list of files is displayed. The parameter block is filled in with the file information. All you have to do is examine the information and return TRUE for those files that you do not want in the list, and FALSE for those files you do want in the list. I call this the "No Bananas" routine, because in effect you say "Yes, I don't want this file in the list." Rumor has it that Standard File was originally written in two days. If that's true, it was a heck of a good job, and I can forgive the designers this small idiosyncrasy.

In the demonstration program, I use two added checkboxes to select whether to display applications and documents. The file filter checks the values of these checkboxes and acts accordingly. When both checkboxes are checked, the SFGetFile dialogue acts normally, displaying all files. When the Show Applications

Looking into CAD?

See how VersaCAD on the Macintosh stacks up . . .

When it comes to professional CAD on the Macintosh®, only VersaCAD® offers a complete solution. Now in its fourth release, this bestselling software gives you high-precision color graphics . . . plus unique design capabilities based on Apple Computer's HyperCard™ information management tool.

- 2D drafting rated "Best" at the National Computer Graphics Association shootout
- 3D color shading that's fast and easy, including multiple viewport display
- Exclusive HyperCard stacks for:
 - Bill of materials
 - Parametric design
 - Off-line plotting
 - Attribute database
 - CAD text processor
 - Drawing manager, and more.
- Proven two-way links to PC-CAD, workstations and thousands of productivity programs.

See for yourself how VersaCAD stacks up. Return the coupon for a free demo disk or call (714) 960-7720 today.

VERSACAD®

Macintosh

EDITION

Prime
Personal CAD/CAM

Circle M24 on Reader Service Card (DEALERS: M25)

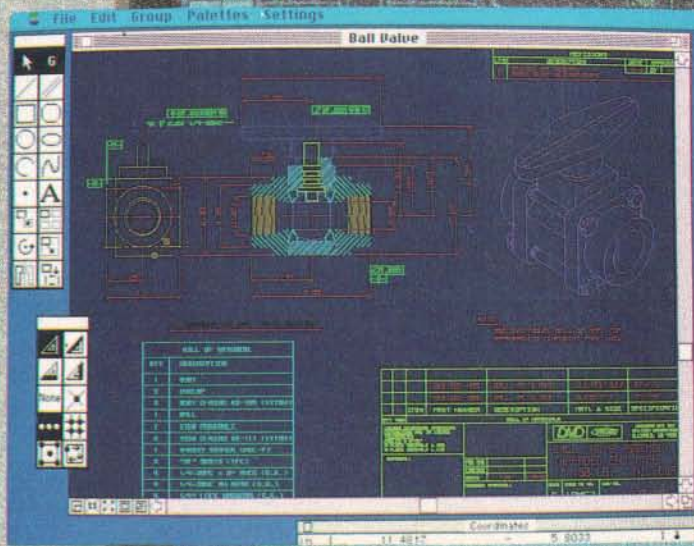
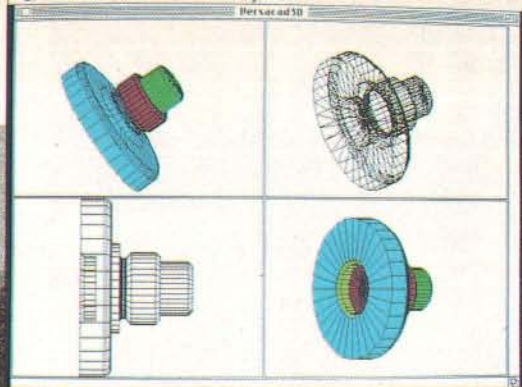

Library	Unit Size	Description	Count	Cost
mech 2	1/8"	nut	39	155.00
mech 3	1/4"	steel rod	3	165.00
mech 5	1/8" X 3"	bolt	39	135.00
mech 12	3/4" X 7 1/4"	shaft	12	75.00
mech 13	1/32"	bearing	4	120.00
mech 19	1/16"	steel bushing	15	155.00
mech 19	1/4"	100 V electro meter	16	175.00
mech 20	17"	base	8	85.00
mech 21	22 1/4"	stand	15	125.00
mech 23	4 1/8"	flange	7	45.54
mech 24	1"	coupler	4	7.56
mech 25	7/16" X 3"	adapter	22	124.55
mech 33	6"	steel shaft	9	65.00
mech 45	1 1/32"	brass flange adapter	1	10.75
mech 49	3 29/64"	bracket	4	22.50

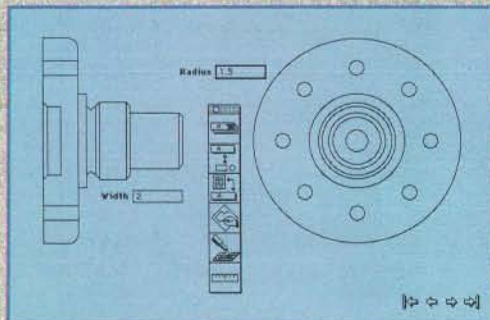

YES, send me a free demo disk (requires a Macintosh Plus or greater).

Name _____

Title _____

Company _____

Address _____

City/State/Zip _____

Phone _____

Please send to Demo Disk, Versacad Corporation, 2124 Main Street, Huntington Beach, CA 92648.

IEEE-Z

IOtech offers the widest selection of **easy-to-use** IEEE 488 (GPIB) interfaces for the Macintosh.

- NuBus IEEE board for the Macintosh II
- SCSI / IEEE controller for the Macintosh Plus, SE & II
- Serial / IEEE controller for long-distance applications
- Serial / IEEE plotter converter for HP-IB plotter interfacing
- Desk accessory software for IEEE control from any application
- Language drivers for IEEE control from Basic, C, Fortran, Pascal, Hypercard and more
- Menu-driven software for scientific analysis and graphics
- **30 day money-back guarantee**
- **2 year warranty**
- **Call or send for your FREE Technical Guide**

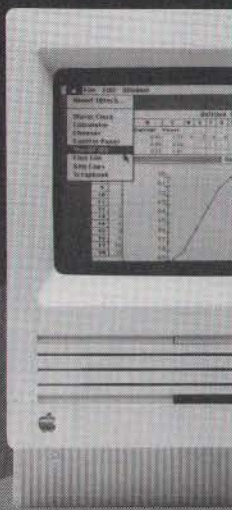

IOtech...the choice is easy

IOtech

(216) 439-4091 Telex 6502820864
Fax (216) 439-4093

25971 Cannon Road • Cleveland, Ohio 44146

London (0734) 86-12-87 • Paris (1) 34810178 • Zurich (01) 821 944
Milan 02-4120360 • Linköping 013 11 01 40 • Gornichem 01830-35333
Sidney (2) 452 3831 • Seoul 784-9942 • Munich and other European,
North African and Middle East countries not listed (089) 710020.

PUSHING STANDARD FILE TO THE LIMIT

SFGetFile dialogue except for the list of names, doesn't it? But there's more here than meets the eye. You see, the regular filename list is actually still there. It has to be, because the pop-up menu that displays the folder path always appears just above the filename list. Besides, Standard File will crash if the standard user-Items are not there (there are two, one for the list and one for the scroll bar). So the filename list is there, but it's only 1 pixel high, and it's hidden behind the top line of the graphical list. Check out the Rez source code I've provided (SF.r—see below), and you'll see what I mean.

Now look at the Open button. It looks normal enough, but in fact the real Open button (which is always item #1) is way off to the right, beyond the edge of the dialogue, where you can't see it. The one you see is item #12, an added control. This little piece of subterfuge is necessary because of the way Standard File handles a click on the Open button.

When the Open button is clicked, Standard File gets the selected item from the filename list. If it's a file, the information for that file is returned, and the dialogue is closed. If it's a folder, the folder is opened and its contents displayed. Since the filename list is hidden, the user can't select anything there. Therefore, you must prevent the normal Open button from ever being clicked, so that you can handle things your own way.

When the fake Open button (item #12) is clicked, your dialogue hook goes into

action. The selected item from your graphical list is retrieved. If it's a file, the information for that file is placed in your global SFReply record, and an item number of 3 is returned. Standard File interprets this as a click on the Cancel button, and the dialogue is closed. This means that the data in the SFReply record that was passed to SFGetFile will be invalid (since Standard File fills it in). That's why you use your global SFReply record, which is filled in by your dialogue hook, instead.

If, when Open is clicked, the selected item is a folder, the routine DownOne() is called. This routine figures out the directory ID of the selected folder and stuffs that into CurDirStore to cause Standard File to display the folder. Then the graphical list is cleared, and the contents of the new folder are displayed. Returning item #101 causes Standard File to redraw its items for the new folder, and everything is in sync again.

The great thing about this method is that Standard File operates completely normally, handling disk insertions and ejections and handling the pop-up folder menu. The only thing your program does is keep track of its own graphical list. Thus, the method is sure to be compatible with future System releases unless Apple changes the rules, and with so many applications depending on Standard File, that's not very likely.

The graphical display used in the demonstration program is very simple, to

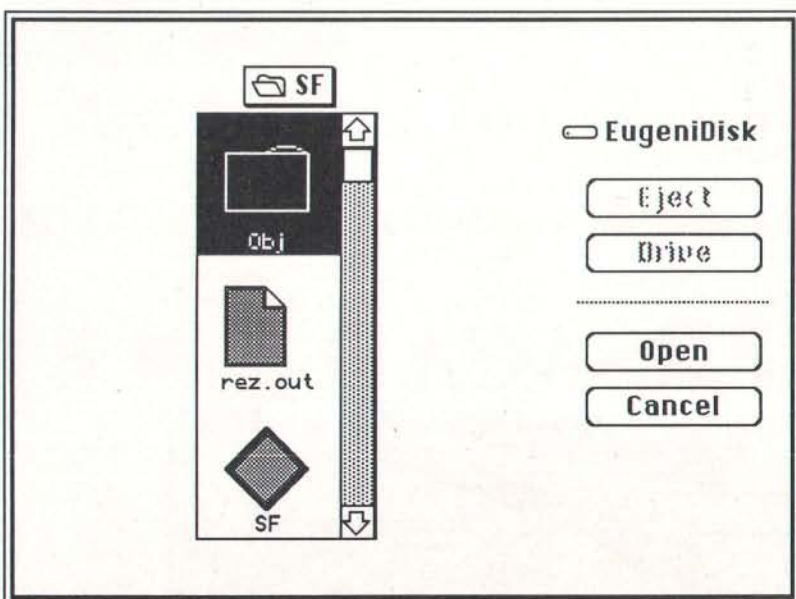

Figure 2: A graphical file list.

FORTRAN Power for Macintosh



Chosen #1 by ...

MACWORLD (March 1989)

Judged Most Powerful by ...

Computer Language (Nov. 1988)

keep the code short and clear. There are three pictures—one of a folder, one of a dog-eared piece of paper, and one of a diamond shape—that are used for folders, documents, and applications, respectively. You could easily modify this to use the actual icon from the file. Or, as I did in my company's product, The Curator, you could display the contents of the file in some graphical form.

One note of caution: With all these techniques at your disposal, it is possible to overload the Standard File dialogue with all kinds of controls, resulting in a confusing user interface. Before you add controls to Standard File, consider whether there are other, better ways to provide the user with the same functionality.

Feel free to write me if you have questions or comments. And if you use any of these techniques in an imaginative way, I'd love to see your program. I'm on BIX as "j.eugenides," on CompuServe as "74065,16," on Delphi as "ASMCOR," on MCI Mail as "Jan Eugenides," and on AppleLink as "D2015."

Source Code

The source code for the demonstration program referred to in this article is too lengthy to be printed here. It is, however, available in a variety of formats (see page 5 for details). It is written in MPW C.

There are several source files:

- SF.c This is the main source module.
- SFList.c This is the list definition for the graphical display.
- SF.r This Rez source file creates the resources.
- SF.h This is the header file.
- SF.make This is the make file.
- UserStartup This is a customized MPW start-up document.

To use the source code, first create a folder in your MPW folder and name it SF. In the SF folder, create another folder and call it Obj. Put all the source files except for UserStartup into the SF folder. Put the UserStartup document into the MPW folder. If you have your own UserStartup file, append the contents of UserStartup to your version.

Run MPW. To build the program, press Command-2. ■

Jan Eugenides is a senior software engineer for Solutions, Inc., in Williston, Vermont. He can be reached on BIX as "j.eugenides."

Full ANSI 77, VAX-compatible extensions, high precision IEEE floating point data types, complete access to the Toolbox, direct code generation for the 68020/030 and 68881/2, and Macintosh Programmer's Workshop (MPW) make the Language Systems compiler the most powerful FORTRAN for the Macintosh.

Language Systems FORTRAN has a full complement of VAX-compatible extensions including structures, nested includes, DO WHILE, IMPLICIT NONE, and all VAX intrinsic functions and data types. Supports even the largest subroutines and functions from VAXes and mainframes.

\$345 (plus shipping).

Runs on all Macintoshes with a hard drive and at least one megabyte of memory, including the new IIx, IIcx, and SE030.

LANGUAGE SYSTEMS
CORPORATION

441 Carlisle Drive, Herndon, VA 22070
(703) 478-0181 fax (703) 689-9593

Rendezvous™ VERSION 2.36

A UNIFIED ELECTRONIC APPOINTMENT DIARY

With an Automatic Reminder Feature to remind you of your appointments while working within any Macintosh application. Fully Mac II and MultiFinder compatible.

12-month
Year Calendar

24-hour
Diary Page

September 1987

52-week
Year Planner

At last a full scale software package that can put you in control of your schedule and help you manage your time more effectively. Yes, Rendezvous is a PERSONAL TIME MANAGEMENT TOOL with all the features you need for now and always. You never need to order another refill for your diary or calendar. Complete with an executive binder for \$200. Plus \$5 shipping.

**PMC Telesystems Inc. P.O. Box 5127 Vancouver, B.C. V6B 4A9
(604) 255-9949**

The fastest way to get here.



Claris CAD can't reduce the huge number of two-dimensional drawings it takes to get a plane off the ground. But it makes them a lot easier to do.



Claris CAD supports ANSI Y14.5 and other drawing standards. So those who design parts can share with those who design wholes.



Accurately drawing graceful curves like these becomes a simple matter of point and click.



Claris CAD can help you design everything from electronic schematics to the box they come in.



Claris CAD is the epitome of "less is more." Less time learning. More time creating.

With the ability to draw in layers, you can hide essential details like wiring and plumbing just a click beneath an elegant exterior.

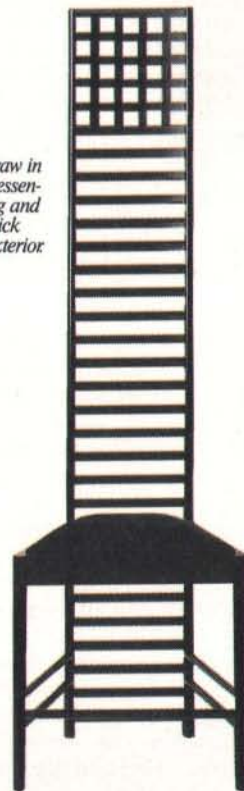

Draw the lines of fine design as finely as you wish: from 1.5 inches to .0001 mm.

Is to start here.

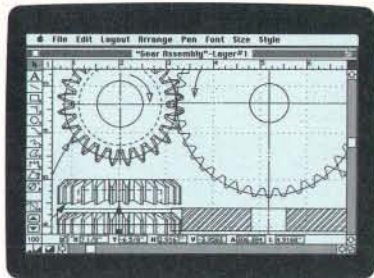

Claris CAD is the first professional 2-D design and drafting tool to fully utilize the intuitive Macintosh way of working. So it takes hours to learn, not days.

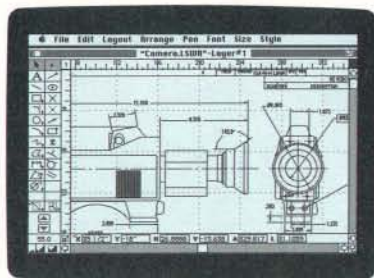

Fillets, tangents, keyboard entry, double lines and automatic dimensioning turn your ideas into realities with exacting precision.

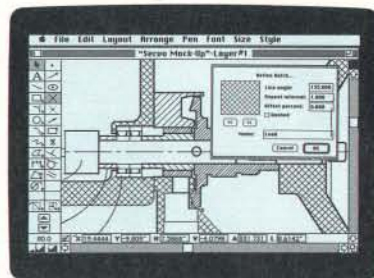

Customizable pens, dashed lines, hatch patterns and dimension appearance give you a new level of versatility.

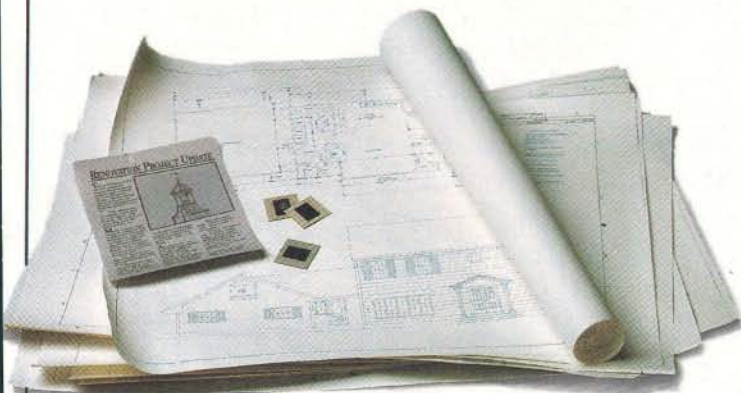

Claris CAD makes it easier to sell your inspirations. Plot your plans, concept sketches, schematics and working drawings exactly as you see them, turn them into slides or overheads, or cut and paste them into proposals and reports.

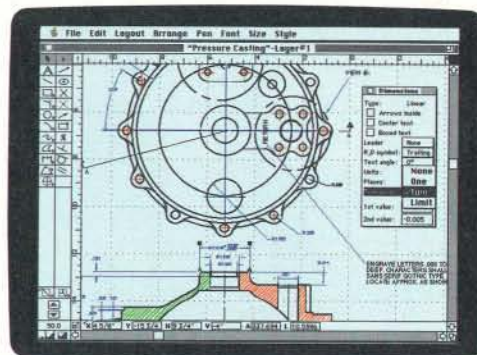

Keeping the vision in your revisions is easy. Because you don't have to redraw from scratch.

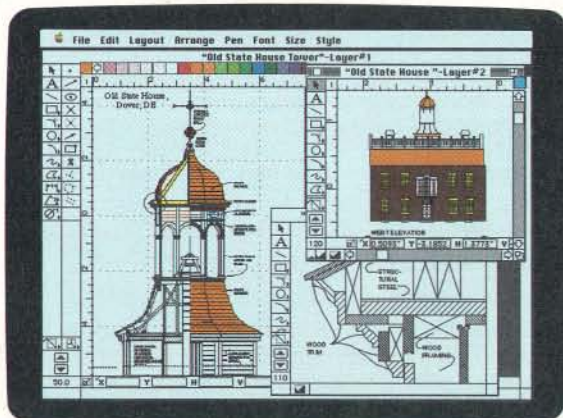

Claris CAD integrates with other CAD software via optional IGES and DXF conversion programs. So you can move them to larger CAD/CAM systems for 3-D modeling and prototyping.



Here's the next step: order the Claris CAD Starter Kit, just \$29.95 (refundable when you buy the complete program). To order, call 800-628-2100. And see how intelligent design begets intelligent design.

Introducing Claris CAD.

introductory price is available to registered MacDraw II users. Call 800-628-2100. Claris is a trademark and MacDraw is a registered trademark of Claris Corporation. Macintosh is a registered trademark of Apple Computer, Inc. DXF is a trademark of AutoDesk, Inc. For the name of the Claris dealer nearest you, call 800-3CLARIS, ext. 200. In Canada, call 800-668-8948.

WE GIVE YOU PCB DESIGN IN SPADES

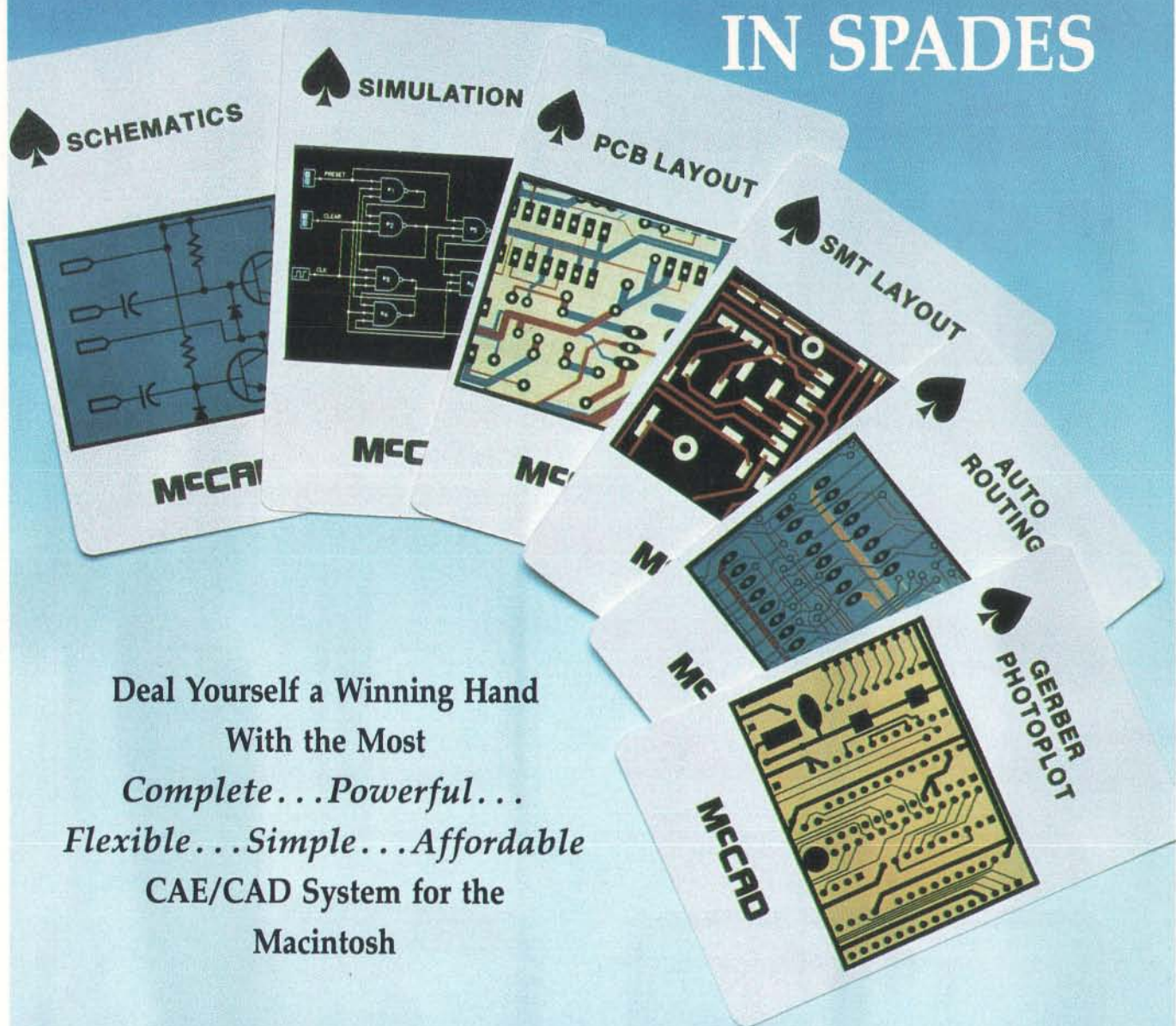

Deal Yourself a Winning Hand
With the Most
Complete...Powerful...
Flexible...Simple...Affordable
CAE/CAD System for the
Macintosh

You can now stack the deck in your favor.

Macintosh has given the electronic designer powerful new tools to work with. And McCAD — the world's leading desktop engineering software for the Mac — gives you the way to press those advantages when designing PCB's. Put it all together and you have a CAD system that's faster and that has more memory, storage and versatility.

Remember, McCAD offers modules that take you from schematics to PCB design to fabrication, with a lot of steps in between. Buy one stand-alone component or the whole integrated system. It's up to you. Mix and match for your own workstation needs.

And easy? If you're tired of user-friendly promises that turn sour with incomplete systems, complicated manuals and convoluted procedures, McCAD is your answer.

You ask about economy? This just might be the best part. Not only does McCAD have the most enticing price tag around, it also gives you the best price-for-performance in the industry. *When it comes to engineering software for the Macintosh, McCAD cannot be underpriced and outperformed by anyone. Period.*

So, it's simple. All you have to do is play your cards right and call us. Then sit back and let McCAD do the rest.

MCCAD[®]
Published by VAMP, Inc.

6753 Selma Ave., Los Angeles, CA 90028
(213) 466-5533 FAX: (213) 466-8564

McCAD is a registered trademark of VAMP, Inc.
Macintosh is a trademark of Apple Computer, Inc.

The Mac Interface: Showing Its Age

Don Crabb

*The best
microcomputer
user interface
needs revamping,
lest it turn from
state-of-the-art
to stodgy*

A month ago, my NeXT computer showed up, with its 17-inch MegaPixel display, 256-megabyte optical disk drive, 660-megabyte hard disk drive, and 400-dot-per-inch laser printer. During my first two weeks with the NeXT computer, my thoughts haven't focused so much on this machine as on the Macintosh. I find myself thinking about how far the Mac has progressed in the last five years and how it compares to the NeXT computer.

Upon considerable reflection, I have to once again give my kudos to Apple for producing what I still think is the best personal computer on the market. Not the fastest. Not the sexiest. Not the most powerful. Not the most expandable. Certainly not the cheapest. Just the best. So why is the Mac the best microcomputer around? Its user interface.

More people can fire up a Macintosh right out of the box and start getting work done the same day. Regardless of arguments to the contrary from devotees of other user interfaces, and regardless of the inroads made on the interface elements that we all think of as distinctly Macintosh (e.g., graphics, icons, mouse, pull-down menus, special sound cues, and many user-definable options), the Mac's interface remains preeminent among those available today.

Unfortunately, during my first month of fiddling with the NeXT computer and its beta 0.8 software and Mach operating system, it has become clear to me that the once state-of-the-art Macintosh interface is really starting to show its age. Regardless of how Apple modifies the Macintosh operating system over the next couple of years to make it more powerful and better able to extract the full horsepower out of its hardware, the company must also extend and improve its aging user interface.

I've put together a list of possible improvements for future Mac interfaces. It's quite likely that some of these ideas couldn't be easily applied without an ex-

tensive overhaul of the System, Finder, and MultiFinder. So be it.

Apple's real competitive advantage in today's microcomputer market is the Macintosh user interface. In fact, that's always been the case. That's why I (unlike other industry watchers) don't really have a problem with Apple's "look and feel" lawsuit against Hewlett-Packard and Microsoft. Apple should protect its intellectual property.

Regardless of whether the company has a legal leg to stand on in its suit, Apple's moral obligations are quite clear: It owes it to its shareholders and customers (many of whom put their professional lives in jeopardy to bring Macs into their companies a few years ago) to protect the interface from being ripped off by competitors. Apple spent considerable time and money on developing the Mac interface; in my opinion, the company is entitled to reap whatever rewards the marketplace deems appropriate for its actions.

My suggestions for improving the Mac interface assume that some important new computing paradigms aren't put on the market by Apple or others over the next two years. If you assume that the

microcomputer interface market will continue to make incremental improvements over that period, then my suggestions fit right in.

Improvements need to be made in six different areas: the desktop, file management, the use of sound, the way windows are displayed and used, general operation, and the integration of development and user environments.

The Apple Desktop has aged less gracefully than any other part of the Macintosh interface. A month's worth of NeXT work, plus daily work with other interfaces, like X Windows, has made this clear to me.

Apple needs to make the Desktop more dynamic, more configurable, and more powerful. For example, why can't you tear off any item on the Mac menu and stick it on the screen (open, of course) where you need it? Sure, you can do this with some individual software, and some shareware utilities add this capability to programs, but it needs to be a standard feature, built in and available to developers.

In the same vein, how about resizable menus? Or how about menu items that you can link to function or option keys for one-time use and that revert back to some status quo? How about the ability to place menus at the bottom of the screen, or on the left or right side, or to get rid of them altogether?

The basic point here is that the current pull-down Mac menus are too staid and too static. You should be able to reconfigure them and store Desktop configuration settings. That way, you can create and save a number of customized working environments attached to specific applications.

Naturally, a configurable Desktop needs some real computing power behind it. To accommodate the interface changes I've suggested, the Macintosh operating system will have to become fully multitasking and will have to offer

continued

WE BUY MACINTOSH

**New & Used Macintosh
In Stock!**

**MAC PARTS – CALL
318-635-1121**

This month's Special Reconditioned SE-20
with Keyboard – \$2250.00

*We buy, sell & horsetrade
popular computers!*

SHREVE SYSTEMS

2421 Malcom St.
Shreveport, Louisiana 71108

PH 318-635-1121 FAX 318-865-2006

MACINTOSH TOOLS FOR ENGINEERS,
SCIENTIST AND APPLIED MATHEMATICIANS

NuTools: Numerical Methods in C

For LightspeedC!

Enter NuTools:

Numerical Methods in C

Numerical Methods in C is a rich combination of 300+ numerical, input and output routines written in C for the LightspeedC environment.

Numerical Features and Capabilities

Numerical Methods in C is developed on a core of numerical types, including real numbers, complex numbers, real vectors, complex vectors, real matrices, complex matrices, polynomials, and rational polynomials. Over 200 numerical routines provide arithmetic operations for all types, matrix operations, vector operations, curve fitting, integration, eigensolvers, differentiation, ODE's, and signal processing.

Enter a complex number

(32.23, 54.12°)

Rectangular Polar Radians Polar Degrees

OK Cancel

Includes extensive documentation, C source, and project files. We accept Visa, Master Card, PO's and checks. **\$125.00**

(509) 525-7120

In and Out

All numerical types are provided with input and output routines. Over 100 routines include entry and display dialogs, file input and output, and simple graphing.

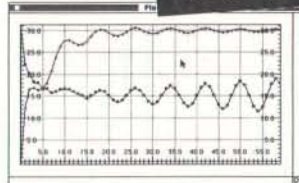

Nicus™

PO Box 612, College Place, WA 99324

© 1989 Nicus. All rights reserved. NuTools, and Numerical Methods in C are trademarks of Nicus. Macintosh is trademark of Apple Computer, Inc. Lightspeed is a trademark of Lightspeed, Inc.

THE MAC INTERFACE

all the features that a fully multitasking system demands. Such features would have to include virtual memory paging, preemptive event scheduling, and inter-process and interapplication communications.

The use
of sound doesn't need
to go far to become
much more effective.

Once Apple has strengthened the Desktop, the company should improve file management capabilities. The biggest change, which could also be categorized as a Desktop or general operational improvement, would be the introduction of a command-line interface.

I'm not arguing here for a return to MS-DOS's C> prompt or Unix's % prompt, but the Mac needs some kind of shell window (similar to Unix running with X Windows or Mach running with NextStep) that can be popped up as needed for direct file management operations. This shell window could also be used instead of pull-down menus if a power user felt so inclined. But the real purpose of the shell window would be to manipulate odd groupings of files in ways that just aren't possible with a mouse but are child's play when done with commands.

To this end, the command-line interpreter needs a Unix-style grep (global regular-expression parser) facility. The grep commands can flag lines of input filenames that match a pattern and copy them to another file. Of course, to be really useful, the improved Mac file manager would have to include many (if not most) of the techniques used in Unix to keep track of files, filenames, and directories. The file manager would also need things like wild-card character support, so groups of files could be manipulated together.

The future Mac operating system shouldn't become a Unix kernel with Mac window dressing, however. If Apple is going to maintain its competitive edge and protect its intellectual property, it makes more sense for the Mac operating system to incorporate the kinds of file management capabilities I've hinted at

THE MAC INTERFACE

here, without resorting to simply "Macifying" Unix. What I'm arguing for is a maturation of the Mac file interface by including features that are common to today's Unix and OS/2 interfaces, the most important of which is the command-line shell.

One way to extend current command-line shell interfaces would be with the improved use of sound. While a Sound Finder has been rumored to be under development by Apple for years, I don't think the use of sound needs to go far to become much more effective than it is now. For example, Farallon's Mac-Recorder has shown just how effective it is to link short sound bites (like quick notes or file descriptions) to files containing other information. Imagine how much more informative it would be if, in the Finder, you could click on a file you'd just created and add a short spoken note to it, a note that could be replayed at any time.

Suppose you have a partially complete C program that a colleague is going to take a look at to help you fix an incorrect algorithm. With the new sound capabilities of the Finder, you could first append an auditory note that plays when the file is opened, telling your colleague where to look for the bad algorithm. In just a few spoken sentences, you could convey more information in that note than you can with a filename or with written comments, because your voice projects inflections and emphasis that written comments lack.

This use of voice annotation is just one way the Finder's management of sound resources could be improved. With the availability of better sound compression and digitization techniques, the increased use of special digital sound-processor chips, and the drop in price of very large hard disk drives and read/write optical disk drives, I have every confidence that the hardware necessary for successful sound management on a Mac will soon be in place.

Did you ever wish you could tile all your Finder windows with a quick Desktop command, or automatically overlap them, or reduce them to icons and sweep them into the corners of your screen? And what about resizing windows in any direction? Why is the Finder limited to a single resizing handle in the bottom right corner of a window?

While the current Macintosh interface does a creditable job of window management, there's significant room for improvement. Overall, the windowing interface should be more flexible, offer more configuration options, and be con-

trollable from the new command-line shell window.

Specifically, with a command-line shell window, you could write special window scripts (since no command-line interface is worthy of the name if it doesn't have its own script language) that could invoke different kinds of windows based on their purpose and environment. Software authors could write programs to invoke a particular style of window, but you could override their choices. Once again, the key improvement is configurability.

A lot of little things have always bugged me about the Mac interface. Why can't I change the fonts (or sizes, or styles) in the menu bar or in the application menu without having to resort to using someone's shareware utility? Why can't I throw away the menu items I don't need from the Desktop or from any application? Why can't I resize icons or get rid of them altogether (without switching to a "Name" view)? Why can't I—well, you get the idea.

When you've used the Mac for as long as I have, you develop a number of pet peeves. I would categorize these as general operational improvements. I'm sure Apple has a bunch of these kinds of suggestions squirreled away, given all the market research the company does. It's time to pull them out and see which ones would really improve the Macintosh interface.

Finally, we come to development and user integration. All the changes I've suggested in this piece are worthless unless MPW/MacApp provides developer support for them. All modifications made to the Macintosh interface need to permeate through third-party applications, rather than appear just on the Desktop.

I hope Apple is working on the next-generation Macintosh operating system and that it includes some of the improvements I've outlined here. Given Apple's responsive nature in the past and its commitment to the extension of the Macintosh computing metaphor, I'd be surprised if we don't start seeing some of these improvements before too long. ■

Don Crabb is the director of laboratories and a senior lecturer for the computer science department at the University of Chicago. He is also a consulting editor for BYTE. He can be reached on BIX as "decrabb."

Your questions and comments are welcome. Write to: Editor, BYTE, One Phoenix Mill Lane, Peterborough, NH 03458.



**HAVING
TROUBLE
FINDING ALL THE
INFORMATION
YOU NEED
ON UNIX®?**

**TAKE THE FIRST
STEP...
CALL DATAPRO
TODAY!**

If you're looking for detailed analysis of the critical issues surrounding UNIX . . . if you need timely information on the products and key players in the industry . . . then turn to Datapro Reports on UNIX Systems & Software.

Updated monthly, this unique new information service is designed to help you discover the opportunities UNIX offers . . . decide how UNIX fits in your organization . . . optimize results while minimizing risk.

Each month, Datapro Reports on UNIX Systems & Software brings you in-depth analyses of everything new and noteworthy in the UNIX market. You receive the most up-to-date, thoroughly researched information available. Information you can put to use in planning your own UNIX strategies.

Find out how much of a difference Datapro can make to your decision-making: call us today at **1-800-DATAPRO** (1-800-328-2776) or use the reader service card.

UNIX® is a registered trademark of AT&T.

datapro



AutoCAD[®] on the Mac.[®] A new window of opportunity opens.

Be sure to see
AUTODESK EXPO '89
at AEC Systems '89
Anaheim Convention Center
June 5-8, 1989

For more information call the
Autodesk EXPO Hotline at
415/332-2344
extension 2799

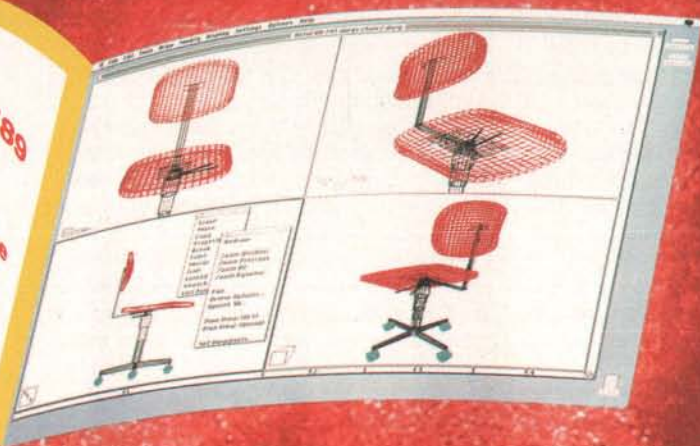

AutoCAD[®], the world-standard CAD software, now runs on your Macintosh[®] II.

Your designs reflect the quality of your thinking. And your drawings reflect the quality of your designs. Put AutoCAD on your Mac II and nothing gets lost in the translation.

AutoCAD's extensive set of drawing tools enhances your productivity. Its effectiveness is proven every day by over 175,000 architectural, civil, construction, aerospace, electrical, cartographic, facility, industrial, manufacturing and mechanical design professionals around the world.

AutoCAD has been refined through ten major upgrades. You get menus full of powerful, high-precision drawing and editing commands, numerous drawing entities, and a multitude of easy-to-use features. You can window, zoom, fillet, scale, layer, annotate and associatively dimension, hatch, stretch and scale. And a simple click can undo anything or everything.

AutoCAD on the Macintosh also supports the features that have made Apple the acknowledged leader in user interface design, offering pull-down, tear-off, and pop-up menus,

support for Multifinder[™] and the Mac windowing system, along with file dialog boxes to make access to your drawing files quick and easy. Clipboard support allows the transfer of AutoCAD drawings to a wide variety of Macintosh applications software.

A Better Perspective. AutoCAD is an advanced three-dimensional modeler that helps you solve design challenges on your Mac the way you would with physical prototypes. AutoCAD makes 3-D easy with user-defined construction planes, dynamic viewing and multiple viewpoints.

You can also model complex surfaces with AutoCAD using sophisticated tools such as tabulated cylinders, surfaces of revolution, ruled surfaces and Coons patches so you can represent surfaces accurately.

For even greater utility, AutoCAD provides entity handles that allow external applications to associate alphanumeric information, such as part numbers and capacity ratings, with graphical elements in the drawing. This associativity is creating an entirely new generation of useful third-party applications software.

A Reflection of You. AutoCAD is an open-architecture system

including AutoLISP[®], an embedded programming language that lets you program AutoCAD to reflect your way of doing things. Add your own menus to enter your own commands, write macros, develop custom symbols and drawing functions, or program standard procedures for document production and management.

Hundreds of third-party programmers have used AutoLISP to develop entire systems that make AutoCAD perfect for applications ranging from chemical engineering to technical publishing. Many of these programs run on the Mac II and more are on their way.

Maintain Your Standards. AutoCAD is the most extensively used, most broadly supported, widely taught design software in the world. AutoCAD is backed by over 1,400 highly-trained dealers and 150 Authorized Training Centers in 60 countries. We'll make sure you get what you expect from your CAD investment. That's what standards are all about.

Opportunity knocks just once. The CAD software you standardize on today will determine your productivity for years to come. To see a demonstration at the dealer nearest you, call Autodesk at 800/445-5415, extension 25, at your earliest opportunity.



AutoCAD makes Macintosh a standard player in CAD applications ranging from architecture to automated manufacturing. And AutoCAD is the standard for communication in the CAD world. AutoCAD's file portability allows seamless transfer of drawings and applications between different platforms and operating systems — without conversion to a generic format.



AUTODESK, INC.

2320 Marinship Way • Sausalito, CA 94965

800/445-5415, Extension 25

Autodesk, the Autodesk logo, AutoCAD and AutoLISP are registered in the U.S. Patent and Trademark Office by Autodesk, Inc. Apple, Mac, and Macintosh are registered trademarks of Apple Computer. Multifinder is a trademark of Apple Computer.

Circle M30 on Reader Service Card

Before you give your next presentation, press this button.

**NEW!
VIDEOSHOW®
FOR YOUR
MACINTOSH**

Turn Desktop Presentations Into Conference Room Power

Your Macintosh® is one of the best tools around for creating great presentation images. Now VideoShow® can take those images into the conference room where you'll really impress your audience with high-resolution presentations in up to 100,000 brilliant colors on screen. And it's as easy as pressing a button.

Create your images with your favorite graphics or presentation software like Microsoft® PowerPoint™, Aldus® Persuasion™, Symantec™ MORE II™, etc. Then take your presentation diskette from your Macintosh into the conference room. Insert it into VideoShow and press the button.

VideoShow turns your images into exciting, board-room-quality presentations with dynamic transition effects, all in brilliant full color. Even if you've created your images on a Mac® SE or Plus.

And your Macintosh can remain in your office while you're in the conference room. Just connect VideoShow to a color monitor or large-screen video projector. Insert your presentation disk, and press the button.

Easy On Your Budget

With three models, starting at \$1795, there's a VideoShow unit to fit every budget and presentation

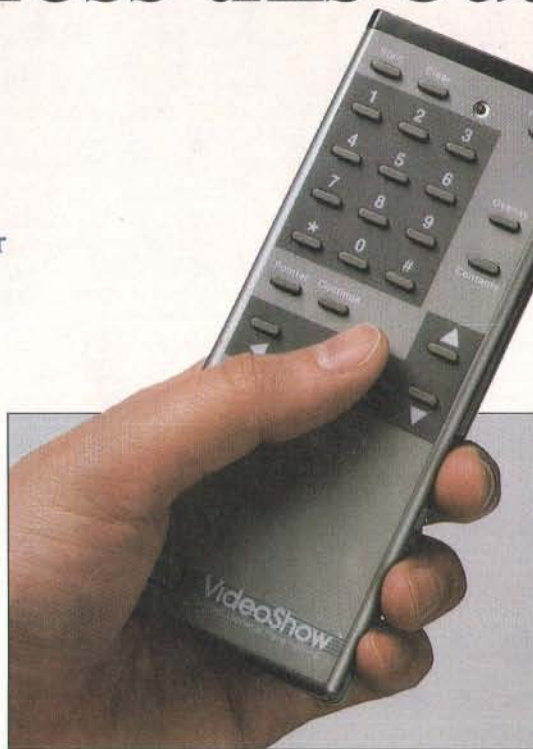

VideoShow's wireless remote control puts you in complete command of your presentation.

need. And VideoShow can operate as the cornerstone of a full system for creating presentations in a variety of media.

Brilliant Slides, Too

When you need professional quality high-resolution slides, simply add PhotoMetric® SlideMaker® to turn your great images into great slides. At your desk. No guesswork. No service bureaus. No delays. No problems.

And Instant Overheads

VideoShow with PrintMaker® software and a color printer, produces sharp, brilliantly colored overhead transparencies and hard-copy handouts. Easily and instantly.

You have to see VideoShow to believe it. Call today 800-556-1234, ext. 234. In California, call 800-441-2345, ext. 234.

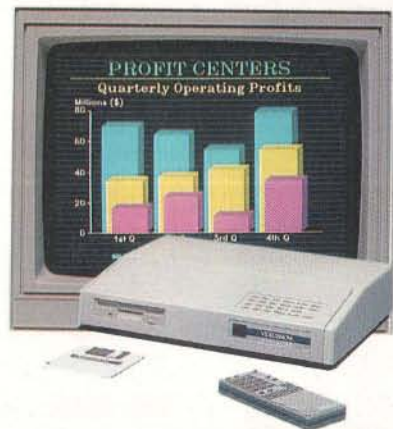

VideoShow is an electronic presentation unit for outstanding conference room presentations.

General Parametrics Corporation The leader in desktop presentation products

Trademark/Owner: Aldus, Persuasion/Aldus Corporation; Mac, Macintosh/Apple Computer, Inc.; PhotoMetric, PrintMaker, SlideMaker, VideoShow/General Parametrics Corporation; Microsoft, PowerPoint/Microsoft Corporation; MORE II, Symantec/Symantec Corporation.

A Portable Companion for the Macintosh

Laurence H. Loeb

*It's not a Mac
 laptop, but the Z88
 plugs the gap nicely*

You know the score: All too often you've got to carry work home. This means the Macintosh Plus in the office also has to make the trip. However, the Mac Plus is only luggable; while I can take it home, there's no way I can use it on my trips in the field. For those occasions I need a laptop, of course. As I write this, there's still no Mac laptop from Apple, so any laptop I pick *must* be able to transfer information to and from my office Mac.

A small text-only machine is usually fine for most work, particularly for telecommunications. However, I also use a spreadsheet to tally the figures I take in the field, and it's crucial that these numbers can be fed into the Mac Plus when I return. This is where the text-only capabilities of most laptops let me down.

A Laptop That's Loaded

Imagine my surprise when I found out about Cambridge's Z88, packaged as a system called MacLite. The package starts with the sleek 8½- by 11½- by 7⁄8-inch Cambridge Z88 laptop that weighs only 2 pounds. For a laptop this size, it's loaded: It has 32K bytes of on-board RAM, 128K bytes of system ROM, and 128K bytes of cartridge RAM. It still sounds rather ordinary, doesn't it? That's where the other parts of the MacLite package come into the picture. First, there's the all-important interface cable that connects the Z88's DB-9 serial port to the mini-DIN-8 serial port on the Mac. Next, there's a 32K-byte EPROM cartridge with a special program that manages the data transfer between the Z88 and the Mac. Finally, there's the 800K-byte floppy disk with Cambridge's Link application on it that handles the Mac's end of a data transfer. Not to mention the manuals to go with all of it.

Simply put, here was a complete solution for my fieldwork, not something where I'd have to kludge a cable or some software to make it work. It was all set up and ready to go. As I used it, I thought that the package was nothing short of mi-

raculous. Once I got through the learning curve, it served *all* my needs for a field laptop. The applications that come bundled with the Z88 include Pipedream, which is a nice word processor-cum-spreadsheet, and an assortment of utilities such as a calendar, a clock, a file manager, and a diary. For telecommunications work, there's the optional Dataport 1200 modem and a COMM-88 program, but they aren't part of the MacLite package.

Cartridge Flexibility

Briefly, this is how the machine works. The front side of the Z88 has a clear plastic pull-down panel where up to three cartridges can be inserted. These cartridges can consist of RAM, ROM, or EEPROM, although an EEPROM cartridge must occupy the third, or rightmost, slot. RAM cartridges come in 128K bytes or 512K bytes. You can fill the Z88 with up to 1.5 megabytes of RAM using three 512K-byte memory cartridges. For my field-to-Mac work, a more practical layout is to have 512K bytes of memory in one slot, the Mac-to-Z88 link program cartridge in another slot, and an EEPROM cartridge or the modem program in the third slot.

The only fully reliable way to save files is to put them on the nonvolatile EEPROM, using a special file command ("copy to EPROM") available from within the file maintenance program. However, you must erase the entire EEPROM at one shot. This makes the chore of saving files a bit convoluted. If you have a 128K-byte RAM cartridge and a 128K-byte EEPROM cartridge, you have to copy the EEPROM files to RAM, wipe the EEPROM, and then copy back just the files you need.

How It Resembles the Mac

The equivalent of the Mac Finder on the Z88 is called the Index. You summon Index by pressing the Index key on the

continued

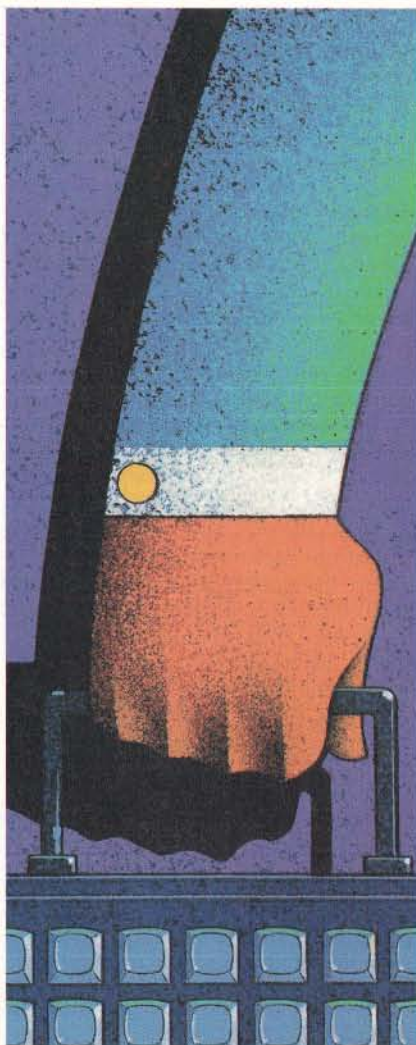

Z88

Company

Cambridge Direct
1419 Lake Cook Rd.
Deerfield, IL 60015
(312) 940-0843

Components

Processor: 8-MHz Z80
Memory: 32K bytes of internal RAM; external RAM expandable to 1.5 megabytes; 128K bytes of ROM
Mass storage: 128K-byte EEPROM cartridges; 128K-byte and 512K-byte RAM cartridges
Display: 8-row by 106-column supertwist blue LCD display
Keyboard: 64 keys; QWERTY arrangement
I/O interfaces: DB-9 serial port; three cartridge slots for RAM or ROM with proprietary connector
Power: Four AA alkaline batteries or external 6-volt connector

Size

8½ x 11½ x 7⁄8 inches; 2 pounds

Software

Includes Pipedream (word processor and spreadsheet combined); utilities include clock, calendar, diary, alarm, file management, import-export, VT-52 terminal program, and BBC BASIC in ROM

Options

128K-byte RAM card: \$110
512K-byte RAM card: \$440
1200-/300-bps portable modem, COMM-88 program on ROM card, and cable: \$259

Documentation

User's Guide with index

Price

MacLite combination (Z88, 128K-byte RAM card, Mac-to-Z88 conversion card, Mac disk, and cabling): \$899

Inquiry M202.

bottom left of the keyboard, and it shows the programs available for execution on the leftmost part of the screen. The list includes any commercial programs in the cartridge slots, such as the Link or modem programs.

There's a Square key (so called because it has a square on it) that accesses these "pop-down" programs at any point. For instance, pressing the Square key and the C key brings up the built-in Calendar program in its own little window. Pressing the Escape key gets you

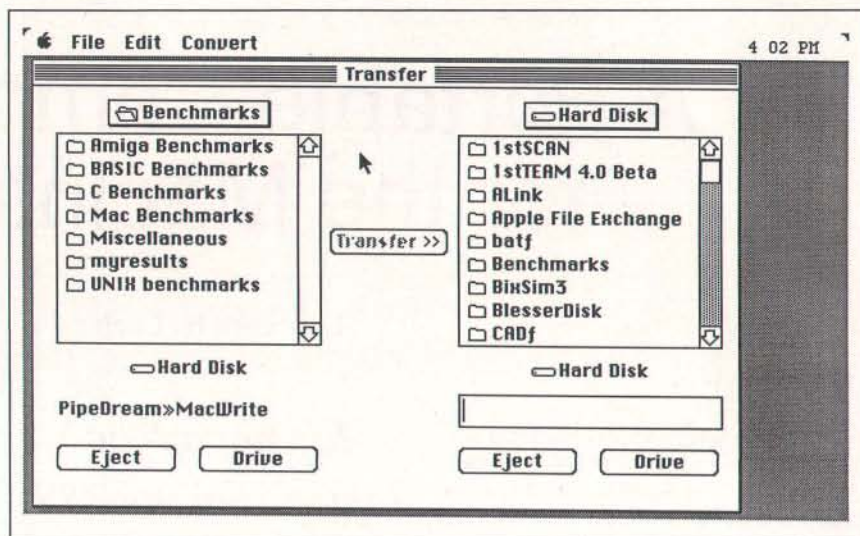

The Link application in operation on the Mac. It manages the transfer of files between the Z88 and the Mac and provides format translation as required. It's similar in operation to the Apple File Exchange application, which handles the transfer of MS-DOS files to and from an MS-DOS floppy in the Mac's floppy disk high-density drive.

out of the Calendar program and back to your current activity. These pop-downs are rather familiar to Mac users as desk accessories and function much like them.

The OZ (yes, that's its real name) operating system of the Z88 allows very fast switching between applications. You can suspend the current application, go on and do something else, and then return to the previous application at exactly the point you left it. This is very handy and sophisticated stuff for an operating system to be doing for you.

One of the main things an operating system like this does is start you off immediately where you were when you last shut off the machine. If I stop working in the telecommunications program, shut off the machine, and then power it up again, the telecommunications program is still there. I don't have to go to the Index unless I want to.

The major part of the Index screen shows what applications were started and when they were suspended. If you want to jump to a specific application, just select it with the cursor keys and press Enter, and you're there.

The Z88 does not link documents with applications the way that the Mac Finder does (i.e., when you open any document, the Finder automatically loads the word processor that created the document). However, the Index does save the last document that the application was working with and loads it when you restart the application.

The Filer program allows you to manipulate the files in any memory area of the Z88. Whether that memory is internal to the Z88 or on a card doesn't matter. What memory you are operating on will be chosen in the default device setting. This also affects where Pipedream saves a file in the future. However, you can override any defaults in effect by using the full path name for a file. Say you wanted to load a file that resides in the folder that the Filer is set to. In this case, you would simply type in the file's name. But if you wanted a file on another memory device in another directory, you would type :RAM.x/directory1/directory2/./directoryN/filename. This redirection technique works for saving a file as well. It gives you a way to short-circuit the Filer when desired, yet retains the ease of use of not having to type all the unnecessary specifiers routinely. Once you get the hang of things, it works rather well.

Z88 applications are organized to provide a listing of applicable keystroke functions. That is, when the Menu key is pressed, a list of the application's commands appears on the screen, organized by function. You select the desired function with the cursor keys, and the key commands for that menu appear. In short, it's an on-line help system for an application's commands. I did not have to carry around the manual to look up how to get things done, and that was a relief. And quite like a Mac.

continued

A family Tree with impressive roots.



Now there's an XTree product for everyone.



In 1985, XTree disk management software unveiled a simple, yet powerful idea: a tree-like directory that displays the entire disk organization at a glance.

Suddenly, even beginners could manage disk files like seasoned professionals.

That's why more than a million copies of XTree and XTreePro are in use today. XTree has twice been named *PC Magazine* product of the year...XTreePro named *Infoworld* Editor's Choice in 1988. And that's why so many well-known software developers are imitating our famous tree-structure.

But while they were copying our previous release, we were writing our next. And created XTreePro for more speed and greater capacity; XTreeNet to manage disk drives across an entire Novell® network; XTreeMac to make the Macintosh® more powerful and flexible. And more branches for our family Tree are on the way.

Call 800/634-5545, (800/551-5353 or 805/541-0604 in CA) for the authorized XTree reseller nearest you, or for a listing of our international distributors.

Because whatever computer system you use, there's an XTree disk management product that can make your life easier.



The world leader
in disk management.

XTree, XTreePro, XTreeNet, and XTreeMac are trademarks of XTree Company, a division of Executive Systems, Inc. Macintosh is a registered trademark of Apple Computer. Novell is a registered trademark of Novell Corp. Programs are not copy protected. © 1989, Executive Systems, Inc. 4330 Santa Fe Road, San Luis Obispo, CA 93401.

Importing and Exporting

The Mac-to-Z88 transfer program resembles the Mac's Apple File Exchange application (see figure) and operates the same way. You select the file on the Mac that you wish to transmit to the Z88, or the folder that's to receive a file from the Z88. On the Z88, you select the memory device and folder in a similar manner. The Link program worked reliably both ways every time I used it.

For plain text files, you don't have to

bother with data conversion. Or you can be very specific about the type of conversion, such as to and from the Pipedream program. The beauty of Pipedream's dual identity as a spreadsheet/word processor is that you can take a Pipedream file and make it into a text-only file, a MacWrite document, or an Excel spreadsheet, depending upon the file's contents.

Unfortunately, while the software was up to the task, the hardware wasn't. Spe-

cifically, the interface cable that connects the two computers didn't quite make reliable contact to the Mac's mini-DIN-8 serial port pins. A bad interface cable makes file transfers unreliable and defeats the whole purpose of MacLite. Cambridge seems to have recently fixed this problem, but some bad cables did get shipped—one of them to me. My advice is that you check that your interface cable works before buying the package.

Also included with the MacLite software is a HyperCard stack, HC Organiser, which serves as an electronic Day-Timer book of names, addresses, notes, and to-do lists, similar in function to Focal Point II. HC Organiser downloads this data onto the Z88 so you can take your contact and scheduling information with you. For Focal Point II users, HC Organiser will download the information from those stacks instead. I didn't use this stack much, because my reasons for using the Z88 were not to call on people. However, I could see its potential use as a super address/note book.

Not Quite a Mac, but Uses Its Data

All in all, I like the Z88. I don't think it's a machine for use as your only computer, however. The closed way of loading programs through cartridges and the current lack of available mass external storage preclude this. As with any scaled-down laptop, I can put up with its quirks to get what I need done. I have not found another computer in its price range that is as versatile or fulfills my needs for a laptop computer as well.

The major job the MacLite package does for me is the ready exchange of information between the Z88 and my Mac. It does this quickly and effectively without my resorting to rocket science to get it to work.

The Index, pop-down program utilities, and built-in menu scheme are reminiscent of how the Mac operates and eliminate much of the hassle of trying to remember the different command sets for each computer. The ability to move information—either as a written report or as spreadsheet numbers—between the two systems was reliable. Incidentally, the Z88 can also transfer files to PC compatibles via a Link program similar to the Mac's. This one feature alone may be useful to those who work within mixed computing environments. ■

Laurence H. Loeb is an electrical-engineer-turned-dental-surgeon in Wallingford, Connecticut. He is comoderator of the Macintosh Exchange on BIX. He can be reached on BIX as "lloeb."

This space
represents the
potential memory
available in
your Mac.

But this
is all you've
got.

Until now. But now there's a way to take full advantage of the Macintosh operating system's 8 megabyte capacity—without shelling out megabucks for expensive memory chips.

Introducing VIRTUAL—the virtual memory software for the Macintosh II, IIx, IIcx and SE/30. By putting information normally stored in RAM on your hard disk—and retrieving it transparently as required—VIRTUAL allows you to run multiple "memory hogs" concurrently under Multifinder. And at just \$295 (or \$695 for the Macintosh II), VIRTUAL not only helps with memory that's too full... it also helps keep your checkbook from getting too empty.

To order, call 415/324-0727.

MEGABYTES NOT MEGABUCKS CONNECTIX

Connectix Corp. 125 Constitution Dr. Menlo Park, CA 94025



Pop Quiz. *Stop. This is a test. For the next 60 seconds, we will be conducting a quiz about Macintosh® II Videographics. Do not turn the page until you have looked at the visual clue and answered all the questions.*

Which Macintosh II graphics card offers the widest range of capture and display resolutions—NTSC, PAL, Apple® Monitor, hi-res, interlaced, non-interlaced and other modes?

a) NuVista 2M b) NuVista 4M c) All of the above

Name the only videographics card which provides true-color, real-time capture and broadcast-quality display while occupying only a single slot in a Macintosh II.

a) NuVista 2M b) NuVista 4M c) All of the above

Which videographics card offers full QuickDraw™ compatibility at 1,2,4,8,16 or 32-bits per pixel?

a) NuVista 2M b) NuVista 4M c) All of the above

Visual clue for Videographics test.

If you chose (c) on all three questions, congratulations! You know that the NuVista series from Truevision is the answer to all your advanced videographics needs. The NuVista is available with either 2Megabytes or 4Megabytes of video memory, and creates professional video effects and computer graphics using any QuickDraw compatible software, now and in the future. No patches, no gimmicks, no hassles.

So whether your application is video production, digital prepress, presentation graphics or 3D renderings, you'll find the NuVista will pass *your* test with flying colors. Oh, and if you answered (a) or (b) to any question above, give yourself half credit. Then obtain even more NuVista information by requesting a copy of our educational brochure True color? True answers. or visiting your local Authorized Truevision Reseller. Either way, you can find all the answers with a NuVista. Call us at **800-858-TRUE.**

You may now return to your regular reading.

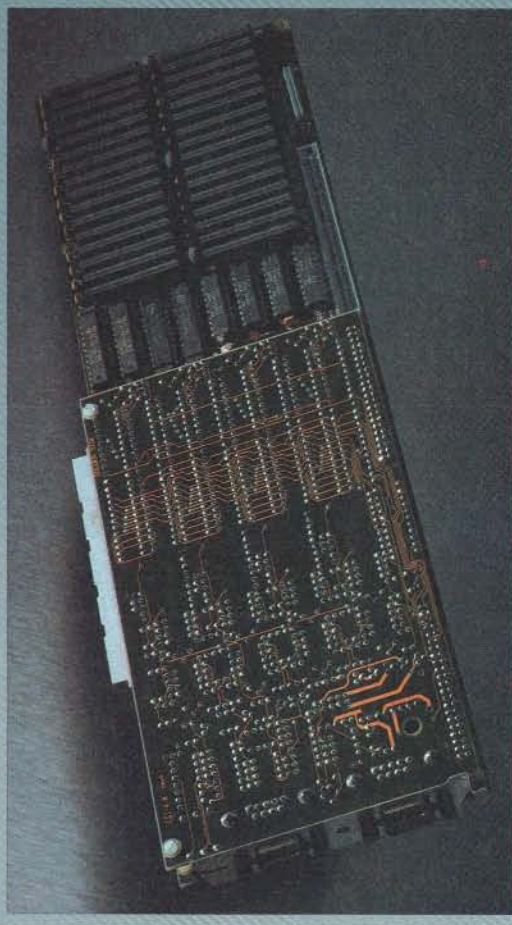

7351 Shadeland Station, Suite 100, Indianapolis, IN 46256

INTERNATIONAL: Canada 416/499-9400 France 33-13-952-6253 Italy 39-2-242-4551 Switzerland 41-1-825-0949 U.K. 44-1-991-0121
West Germany 49-89-612-0010 Other 617-229-6900

Apple and Macintosh are registered trademarks and Quick Draw is a trademark of Apple Computer. Truevision is a registered trademark and NuVista is a trademark of Truevision, Inc.
© Truevision Inc. 1989

Circle 280 on Reader Service Card

It syncs to

The fact that you're considering a Macintosh II shows you're serious about computers. That you want to reach as far as a great system will let you. So you can reach your potential.

Well, now there's a way to go even further.

By giving your Mac II a MacSync™ monitor from NEC.

MacSync is designed solely for the Macintosh II Video Card. And because it is the

direct result of some meaningful conversations with Mac II users, it has all the features you've always wanted in a monitor.

For instance, you asked for easier, more convenient controls. So we moved them up front. You also wanted a 14" non-glare screen to reduce



the Macs.

fatigue. A smaller footprint and a tilt-swivel base, for more comfortable viewing. They're yours. What's more, we give you a cabinet that looks as good from the back as it does from the front. And a HyperCard stack

on-screen user reference guide called MacSync Valet.™

All at no extra cost.

And if you don't mind us saying so, that's the least you and your Macintosh II deserve.



Designed and optimized just for the Macintosh II.

MacSync from NEC. We've taken everything we've learned about

Macintosh II Video Card is a trademark of Apple Computer, Inc.

making great color monitors. And applied it to the Macs.

Macintosh and HyperCard are registered trademarks of Apple Computer, Inc.

For literature, call 1-800-826-2255. For technical details, call NEC

MacSync and MacSync Valet are trademarks of NEC Home Electronics (USA) Inc.

Home Electronics (USA) Inc. 1-800-FONE-NEC.

© 1989 NEC Home Electronics (USA) Inc.

NEC

Enter The New Age of Electronic CAD

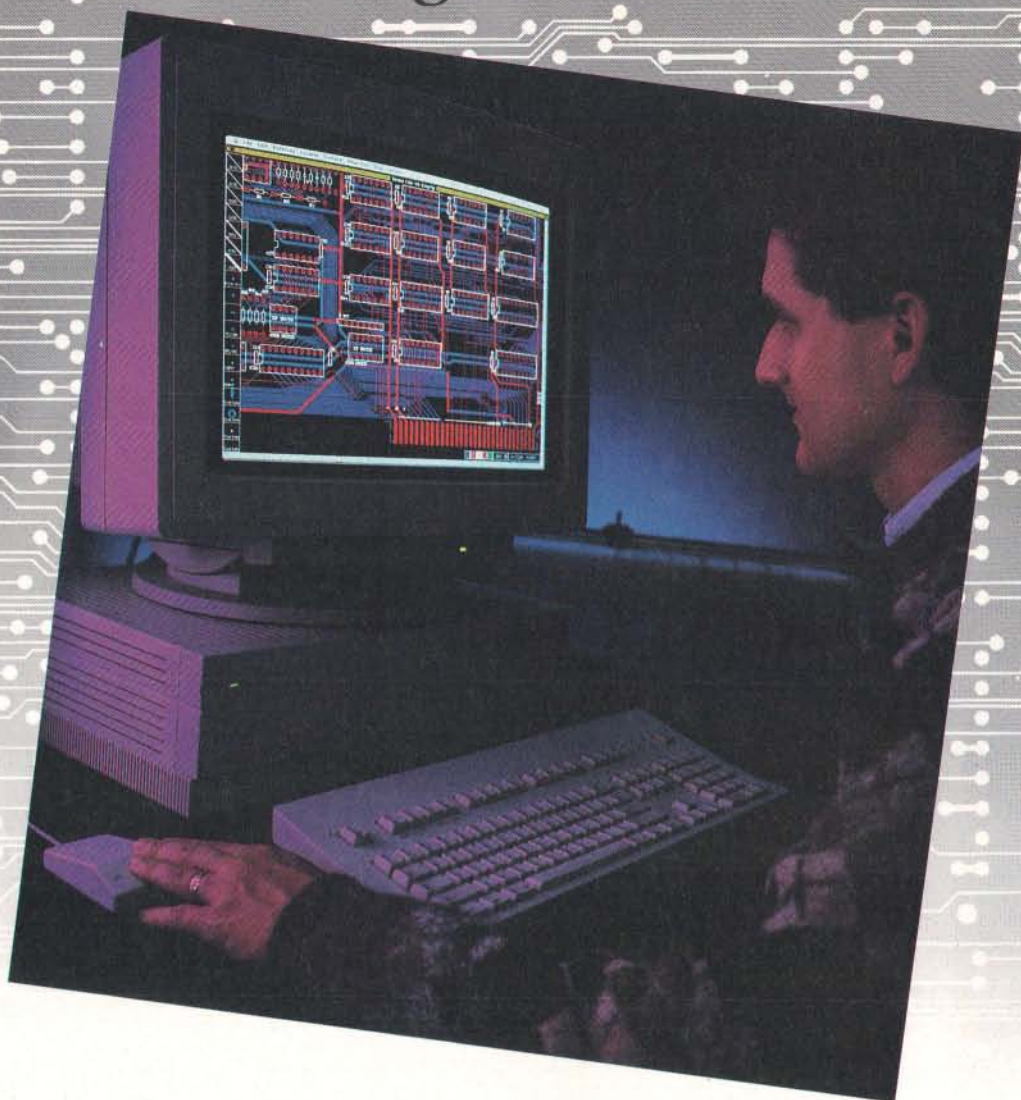

The wait is over for a powerful, easy to use electronic design workstation.

With the new Douglas CAD/CAM Professional System, you can now experience computer-aided design without going over budget and without sitting through months of tedious training. Running on the Apple Macintosh Plus, SE and II, the Professional System from Douglas Electronics excels in price/performance, short learning curves and ease of use.

As the newest addition to the Douglas CAD/CAM line of printed circuit board design and manufacturing systems, the Professional System is a fully integrated engineering tool that will take you from the schematic drawing to the final routed board. The software features full color, unlimited multi-

Circle M8 on Reader Service Card

layers and .001" control which makes surface mount technology (SMT) and other difficult tasks a snap. Professional Layout includes a parts placement facility. Schematic includes fully interactive digital simulation and net list generation. A flexible, multi-pass router completes the design cycle with a 16 layer routing capability.

The new age of electronic CAD has come with the high resolution and speed of a Macintosh engineering workstation. You'll be designing your first circuit board just minutes after the Professional System software has been loaded into your computer. In addition, the Macintosh's graphics capa-

bilities allow for powerful features such as the ability to transfer Professional System drawings into final engineering documentation.

Computer-aided design wasn't meant to be time consuming and complicated. If your present CAD system has got the best of you, it may be time you enter the new age of electronic CAD with the powerful, easy to use Douglas CAD/CAM Professional System.

Take your first step by ordering a full-feature Demo. All three programs are included for just \$25.

Call or write for more information and to place your order.

Douglas
Electronics

718 Marina Blvd.
San Leandro, CA 94577
(415) 483-8770

Mixed Blessings

Jerry Pournelle

Despite various drawbacks, the Mac is rapidly becoming indispensable at Chaos Manor

Whatever else you can say about the Macintosh, it isn't dull. I got an undeserved reputation as a Macintosh hater because I wasn't overly impressed with the original 128K-byte Mac; but what I really said was that the hardware wasn't up to the conception and the hype. Still, even that original Mac wasn't *dull*, although it was a bit short on vital features.

In fact, the Mac can be just plain fun. Look at mine: there's a background picture on the screen when it starts up. There's SoundMaster, a neat shareware utility for adding and changing sounds. When I insert a floppy disk, Darth Vader informs me that he's "here to put me back on schedule"; restarting the machine gets Mr. Spock proclaiming that this should prove "interesting"; and when I shut the Mac down, a bell clangs and a gravedigger calls, "Bring out your dead!"

Try that on your PC-compatible.

Problems

You should by now have the impression that I'm quite fond of the Mac. All true. The Mac II has become more than "good enough" for anything you'd want a microcomputer for.

The newest Mac IIx is getting there, but it does require a spirit of adventure. I have one with 5 megabytes of memory and the new System software version 6.0.3. If I used only standard software in standard ways, I expect it would be all right; but, alas, I am getting very used to System Error Bombs. I make no doubt that Apple will get software worthy of the Mac IIx hardware, but I do wish they'd get on with it.

For example: I got a bomb every time I tried to open a MacWrite document from anywhere but the MacWrite folder. This was so annoying that I asked BYTE's Mac guru Tom Thompson for advice.

He said to first disconnect the 330-megabyte Priam MacDisk; second, boot with the new System software from the original floppy disk; third, run Disk

First Aid (which is more like IBM PC's CHKDSK.COM than it's like Norton Disk Doctor) off the original distribution floppy disk; fourth, run an antivirus program; and finally, check to see that I have a good copy of MacWrite.

It all seemed like good advice, the kind of thing I could do on my Cheetah 386 in about 10 minutes; but it took hours.

It's so easy to *learn* the Mac that you think you don't have to know much to use it. While that's generally true, it also means that many Mac users are completely confused when something goes wrong. I know I certainly am.

Could I be running too many initialization programs? Should I set the Mac System beep back to just "beep" when it wants my attention, instead of doing a "Kaboom!"? Ought I to strangle Darth Vader and Mr. Spock? Do we have a bad memory board or a bad sector on the hard disk? How can I find out?

Alas, Apple's documents don't tell much. Still, persistence pays.

Item: I solved the problem of System Error #02 (Address Error) when opening MacWrite from a document distant from the MacWrite file itself. I used the Find File desk accessory (DA) to search for MacWrite, and lo! It turns out that buried deep in the PowerPoint folder is a folder called Phil's Stuff; inside that is a folder called Phil's Stories; and inside that was

another copy of MacWrite. On general principles, I threw it in the Trash, then tried to open a MacWrite document. The machine insisted that I get the old one out of the Trash. I refused to do it. It kept insisting. I emptied the Trash. The system crashed—System Error #02.

I rebooted the system, and the problem was gone. I can start MacWrite from anywhere on that disk without crashing the system. On the other hand, I don't—and apparently can't—have a second copy of MacWrite anywhere on the system, in any folder on the MacDisk. Why?

Also, an attempt to start MacWrite by clicking on a MacWrite document on the internal 80-megabyte Apple hard disk drive produced another crash, and this wasn't even as graceful as the "Sorry, a System Error Occurred" dialog box. The MacWrite logo appeared for a moment, the screen got covered with jumpy lines, and it was time to hit the Reset button. That problem was solved by moving one—and only one—copy of MacWrite onto the Apple boot disk.

I thought I had another solution, booting the Mac while holding down the Command (Splat) and Option (Alt) keys simultaneously. This not-well-documented procedure rebuilds the Desktop file, and Mac experts recommend that you do it every couple of weeks. Alas, while it's probably a good thing to do, it hasn't cured the situation. I suppose that's a small price to pay for the convenience of the Mac.

What to Do Until the Doctor Comes

Whatever the reason, I've had plenty of practice dealing with lockups and system crashes. Here in a nutshell are the procedures I've learned.

First, every time you have a system crash, run Disk First Aid. Do that religiously. Since you'll probably be running it from the hard disk, the program will tell you that it can't fix any problems. That's all right. What you're after

continued

is assurance that there aren't any problems that have to be fixed.

If there's a second crash, again run Disk First Aid. Also, if there's a chance that your system has been invaded—if, for instance, you're getting bizarre results, or you've recently introduced software from an unidentified source—run a virus-detection program.

Incidentally, you should also have Vaccine or some other virus-prevention program as the first thing in your INIT

file. Computer viruses are real, and a fair number of them are masquerading as legitimate freeware and shareware.

If you still get bizarre results, don't try to figure them out. When you're sure that something odd is happening, get out your original System Tools floppy disk. Open the write-protect doohickey and leave it open, then boot up the system, and replace your System files. (Your fonts will now be gone and will have to be reinstalled. In the Mac, fonts reside in

the System file.) In doing that, don't—as I did late one night—just drag the System Folder on the floppy disk over to the hard disk and drop it on the System Folder there. Use the Installer.

Multiple copies of System files cause problems. It's especially serious if you have several versions of the System software. If you think that you should keep backup copies, keep them on floppy disks, not on your hard disk. Even if you have two hard disk drives, as I do, you're better off seeing that there is one and only one System Folder.

The reason for this is built into the Macintosh philosophy. CP/M machines were originally designed for floppy disks only, and they used to have all the system software loaded onto the floppy disk's track zero. The major problem with that was that it set an upper limit on the size of the operating system. IBM solved that by putting much of the operating system into a file called COMMAND.COM. There's still something much like a "system track"; certain hidden system files that tell the computer how to load COMMAND.COM have to be the very first files in the disk directory. However, COMMAND.COM can be anywhere you like; there's no prohibition on multiple copies.

The Macintosh command system is different. There's not only a System file like the IBM PC's COMMAND.COM, there's also a System Folder, which corresponds to a combination of the CONFIG.SYS and AUTOEXEC.BAT files on a PC. But whereas on the PC you would put something such as DEVICE = VACCINE.SYS into the CONFIG.SYS file to get the machine to load the Vaccine program on start-up, on the Mac you simply drag the proper Vaccine initialization file into the System Folder.

So far, it doesn't sound much different from the PC; but now comes the way you invoke (Macintosh people usually use the word "launch") programs. With the PC, if you want to read a common ASCII file, you tell the computer to TYPE FOO.DOC; if you want to be really fancy, you say TYPE FOO.DOC | MORE, which tells the PC to direct the output of the built-in system command TYPE into another program called MORE.COM.

MORE.COM then presents the text one screen at a time and waits for you to hit a key before moving on. On the other hand, if you want to read a non-ASCII document created in a word processor—say, WordStar or WordPerfect—you have to run the word processing program, then load the document into the editor.

continued

Introducing The Gravis MouseStick™
Here's the digital controller that towers above joysticks, mice and trackballs. For speed. For precision. For versatility. For technology. For durability. And just for fun!

For versatility, the MouseStick features three programmable microswitch buttons which can emulate any eight keyboard commands. For technology, there's the

GRIPPING NEWS FOR MOUSE USERS!

For precision, only the Gravis MouseStick features a true opto-mechanical digital output signal, resulting in an amazing 1200 point resolution you can set to any screen size. Plus, fractional sensitivity modes for precise pixel by pixel control.

Gravis MouseStick Processing Unit (GMPU). With 16K of ROM and powerful Control Panel Software, your programming options are virtually limitless, and can be upgraded to include new features! So for large-screen monitor CAD and DTP applications, or serious computer games, get a grip on the future with the incredible Gravis MouseStick. You'll discover that for serious work or serious play, the Gravis MouseStick really handles it!

ADVANCING THE ART

Advanced GRAVIS
Advanced Gravis Computer Technology Ltd.
7033 Antrim Ave., Burnaby, B.C. Canada V5J 4M5
Tel 604-434-7274
US OFFICE:
1602 Carolina St. #D12, Bellingham, WA 98226

The MouseStick is compatible with any Macintosh or Apple IIGS, has all the unique features of the Gravis joystick, and comes with a one-year no-nonsense warranty.

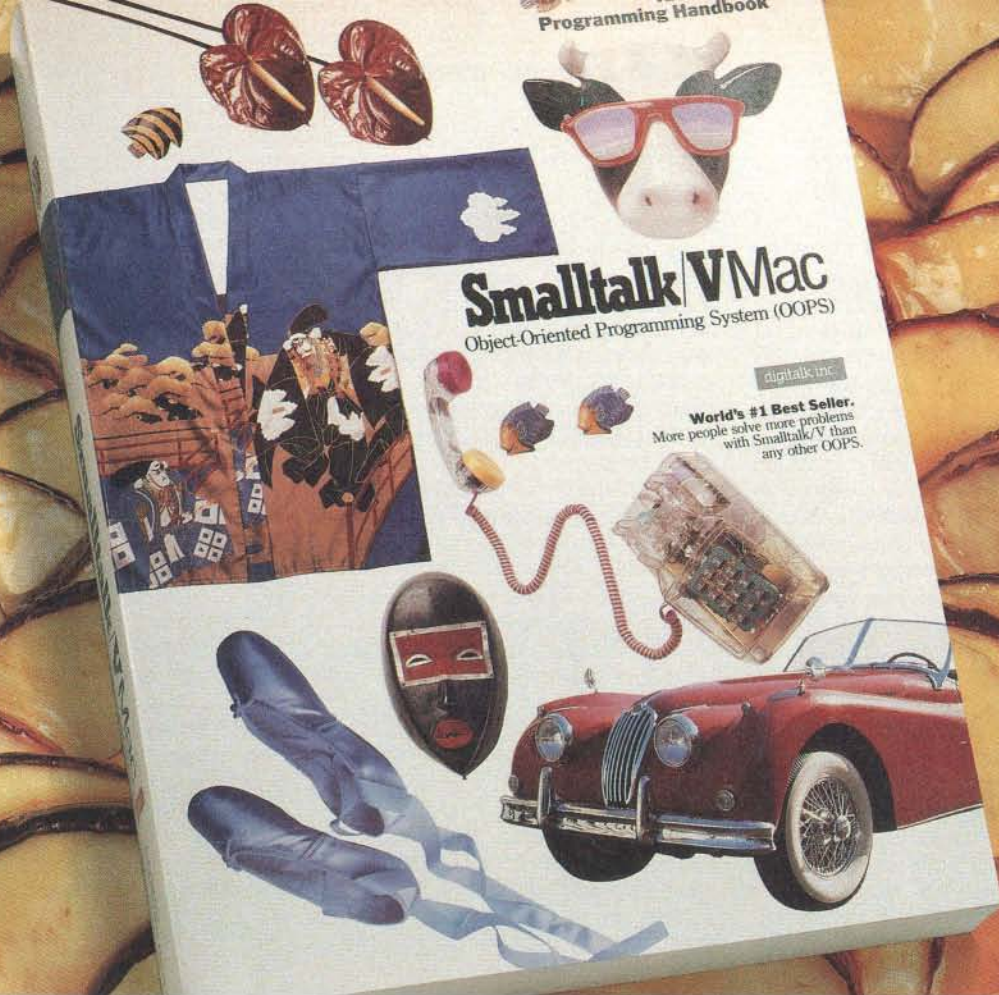

APPLE AND OOPS. A PEACH OF A PAIR.

Romeo and Juliette. Lucy and Desi. Fred and Wilma. Sometimes couples just seem made for each other. And now when you put Smalltalk/V and your Macintosh together you've got a marriage made in heaven.

Object Oriented Programming was made for Macintosh. Smalltalk/VMac lets you develop Mac applications easier than ever before using the prototype style that Smalltalk is famous for. You also get push-button debugging; multi-processing; complete Toolbox access; MultiFinder compatibility; a rich class library; and a bushel basket of Smalltalk source code. All in our high-performance 32-bit architecture.

Interestingly enough, Macintosh was made for OOPS. Much of the unique hardware and interface design in Mac development

came directly from Smalltalk research. This is no casual affair.

Love, it is written, is not selfish or arrogant. So when you become passionately involved with Smalltalk/VMac, your work is fully compatible with Smalltalk/V on IBM PCs (and clones) operating with DOS, OS/2 and Presentation Manager.

The new Smalltalk/VMac sells for a peachy \$199.95 and comes with our no-questions-asked 60 day money-back guarantee.

If your dealer isn't into OOPS, order toll free, 1-800-922-8255. Or write to; Digitalk, Inc., 9841 Airport Blvd., Los Angeles, CA 90045. Smalltalk/V and Apple. Now there's an appealing couple.

Smalltalk/VMac

You can do that with the Mac, but you don't have to. You can launch MacWrite by double-clicking on a MacWrite document, and in theory that document can be in a file folder (PC users can think of folders as directories and subdirectories) unrelated to the location of MacWrite.

That works because a program appropriately called Finder goes out seeking the programs needed to do whatever job you've just commanded the computer to do; and whereas a PC will search only the directories that a PATH command has told it to look into, Finder looks everywhere, including places that you didn't want it to look; and if it finds several programs with the same name, it can get confused.

It gets even more confused if there are multiple copies of the System file on your disk; it can get absolutely schizophrenic if there's a System file buried in a folder inside the System Folder.

All of which is the long way of saying that if you get odd results with your Mac, use the Find File DA to hunt down and kill every last copy of the System file other than the primary one in your System Folder. The active System Folder is the one with a picture of the Mac on it.

Be of Good Cheer

I have painted a much gloomier picture than the Mac deserves. It's true that I get system crashes, but there are reasons.

First, I'm using a Mac IIx. Over the years, I have accumulated a lot of Mac software, and much of it simply isn't very well behaved: it was written without much regard to the published Apple Mac-

intosh interface standard. A case in point: an absolutely delightful program called Strategic Conquest, a war game that used to consume a lot more time than I (or my sons) should have given it. That program runs fine on the Mac Plus. It sort of works on the Mac II, although the sound doesn't. It crashes randomly on the Mac IIx. That's unlikely to be the Mac's fault.

(Incidentally, it's to Apple's credit that they've gone through six major and countless minor revisions of the operating system, taking the Mac from 128K bytes of memory and a 68000 CPU to as much as 8 megabytes of memory and the 68030 CPU, and much of the software from the old machines still runs on the new. Much, but not all; I'm told that the next revision of the operating system will rigidly enforce the standards, and a lot of popular software will no longer run. We'll see.)

Second, sometimes it's partially my fault. The Mac II and IIx have color. A lot of programs, especially those written for earlier Macs, can't handle color. Some of those have warnings. If you're running color and you try to start a program, it says: "Switch to black and white, Turkey." That's easy enough to do on the Mac II and IIx, provided that you remember; but if you don't do it, some black-and-white programs can totally lock up the system. My son Alex has a large collection of shareware games guaranteed to do that. Some of them will lock up the machine even if you have switched to black and white.

Third, I run a lot of software, much of

it developed by people who don't have a Mac IIx. Sometimes their stuff runs fine on the Mac Plus, standard SE, and II, but not the Mac IIx. I haven't the competence to determine whose fault that is.

Fourth, this is a Mac IIx, which is a pretty recent machine. When I buy a car, I am fairly careful not to buy one that's in its first model year.

Finally, this machine is thoroughly loaded. It has two hard disk drives, one the 330-megabyte Priam MacDisk; 5 megabytes of memory; a LaserWriter IINT; an AppleScan scanner; an Apple CD-ROM drive; an AppleFax board; and a 5¼-inch PC drive that reads and writes IBM PC-format disks. Every bit of that equipment works. I doubt there are many systems comparably equipped. I'm sure there are darned few of any brand that can do all the things this Mac IIx routinely does.

Scanning and Charting

The main work done here on the Mac IIx is preparing briefing materials for the Citizen's Advisory Council; our last briefing was given in the White House. The AppleScan monochrome scanner is invaluable for making presentation materials.

We were able to scan in charts, diagrams, and graphs from a great many sources, so that we built up a library of graphics images we can put into our briefing materials. We've been using Microsoft's PowerPoint to do that; it's only one of several programs that have that capability.

continued

dScience

Professional Data Reduction and Analysis Software for the Macintosh.

With dScience, analysis is fast and flexible—and at the click of a mouse no farther away than your Mac.

Data importation is comprehensive, and with just two megabytes of memory, over 220,000 data points can be imported to the data spreadsheet. dScience's data spreadsheet is where plotting, transforming, analyzing and editing happen. Data can be represented either parametrically as functional sets (i.e., $f(x)$), or in matrix form.

Routines to transform your data into meaningful results range from

simple math to two-dimensional Fourier transformations, non-linear fitting to a user defined function, and eigenvalue and eigenvector solutions to generalized nonsymmetrical complex matrices. dScience also provides basic statistics, spline and smoothing functions, and associated operations. Transformed or analyzed data can be edited, saved, exported or plotted for further analysis.

dScience fully supports two-dimensional, contour and surface plottings. Plots can be overlaid

on top of one another, sized to any dimension, assigned colors and magnified.

Additional features of dScience include a mathematical equation evaluator and macros for repetitive tasks.

Also, SPECTRA Blue, Inc. realizes that dScience may not fully address the needs of all researchers. For this reason, SPECTRA Blue, Inc.

can customize dScience to adjust to specific data analysis needs. *Coming Soon.*

Advanced analysis modules such as



image processing.

For more information, contact SPECTRA Blue, Inc. at (602) 296-3899, 7739 E. Broadway #248, Tucson, AZ 85710.

SPECTRA Blue





These unretouched print samples show the superior print quality of QMS-PS 810 over printers using first-generation print engines.



Now \$4995!
Suggested Retail Price.

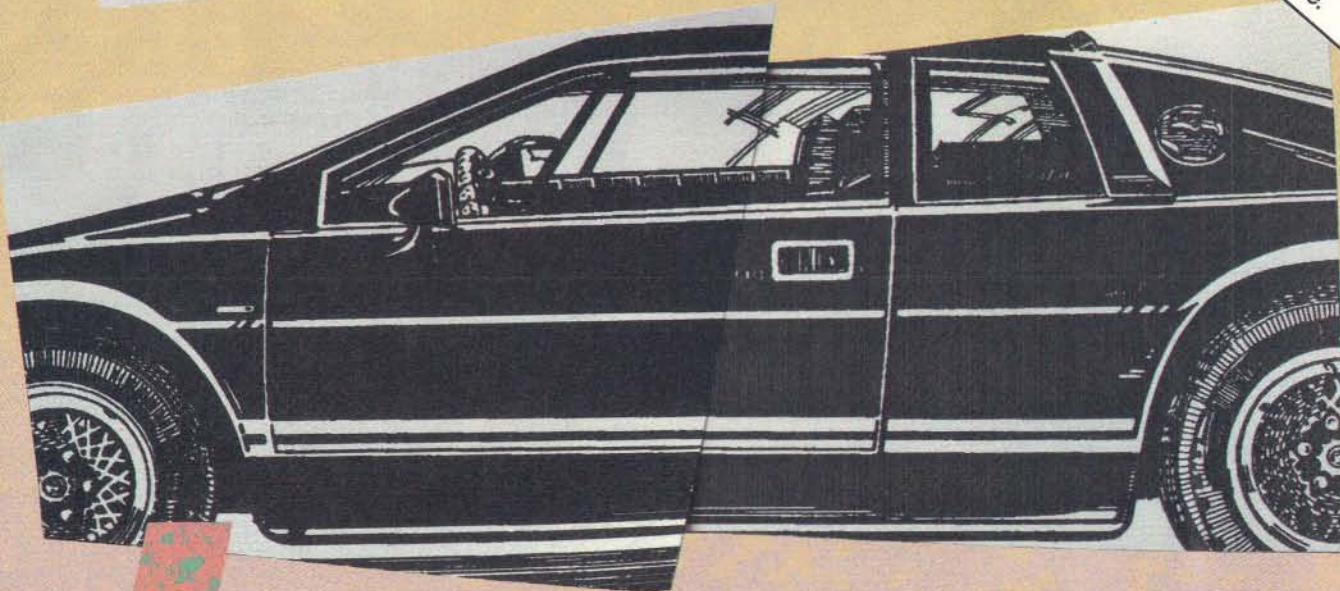

Introducing the PostScript laser printer that blacks out at high speeds.

The new QMS-PS[®] 810 can compose and print the most complex pages in record times, with richer, more saturated blacks than ever before. All with the desktop publishing power of Adobe PostScript[®], and the superior print know-how of QMS, an industry leader.

Under the hood QMS ASAP[™] (Advanced System Architecture for PostScript) is proprietary technology that helps eliminate the hardware bottlenecks that hinder other PostScript printers. As a result, QMS-PS 810 boasts processing speeds remarkably faster than other PostScript printers in its class. And faster output means greater productivity. In addition, the QMS-PS 810 laser

printer's new Canon[®] SX[®] print engine covers solid areas and prints fine detail better than previous-generation engines.

Fast start, strong finish You can adorn your documents with one or all of the 35 Adobe typefaces. Thanks to PostScript, there's an infinite number of font variations available. You can also make type as large or as small as you want. And put it anywhere on the page. In fact, with PostScript you enjoy total control over the design of your page. It gives you the complete desktop publishing power to do things that would otherwise be virtually impossible. So you get high-quality output exactly how you want it.

Along with PostScript, the HP LaserJet +[™], Diablo[®] 630 and HP-GL[™] printer emulations are added for your non-PostScript software.

The QMS-PS 810 laser printer is easy to use, maintain, and comes with a one-year warranty. It's available from Laser Connection dealers. Laser Connection is a sales and marketing subsidiary of QMS. For the dealer nearest you call **1-800-523-2696**.

The new
8-page/minute
QMS-PS 810
laser
printer



LASER CONNECTION[™]

A QMS[®] company

The following are trademarks of their respective companies: QMS, QMS-PS, ASAP, Laser Connection of QMS, Inc. PostScript of Adobe Systems, Inc. Canon, Canon SX of Canon, U.S.A. LaserJet +, HP-GL of Hewlett-Packard, Diablo of Xerox Corp.

©1987 Laser Connection

Circle M33 on Reader Service Card

JUNE 1989 Bonus Mac Supplement • B Y T E MAC 252A

Microcomputer News On-Line

In this fast paced industry, can you afford to wait a week or a month for information that may affect you today?

MicroBYTES Daily is an electronic news service covering the latest developments in the microcomputer industry. If it concerns MS DOS machines, Macintosh, Unix workstations, Amigas, Atari STs, peripherals, networks or software, you will find it in MicroBYTES.

Fast and Easy

Read the items as they break or use the powerful search command to quickly locate your information. Best of all you can download the text and print it or use it in your favorite word processor.

Whether you are a developer, marketer, or researcher, you need reliable information and you can count on MicroBYTES. Backed by the combined resources of BYTE magazine, BYTE-week, and BIX, MicroBYTES gives you access to our world-wide network of reporters and the integrity and experience of our editorial staff.

In your position as a leader in new technology, you cannot afford to be just one of the crowd. Get ahead with MicroBYTES.

Call now and subscribe today.

BIX

One Phoenix Mill Lane
Peterborough, NH 03458
800-227-2983
In NH 603-924-7681

One of our charts is a montage of magazine covers: the ones showing just how serious the U.S. space problems have become. The original covers were in color, of course. For our primary presentation charts, we used photographs; but by playing around with the scan parameters, we were able to get good images of those covers into the Mac. Then we pasted them into our handout materials, since we couldn't really afford color printing; the Citizen's Advisory Council is all volunteers, and we don't take money from the aerospace industry for obvious reasons.

The result was strikingly good, far better than anything we could get out of the best grade of Xerox machine.

Once those files are scanned in, they can also be altered. With suitable paint programs, you can get down to individual dot levels to twiddle with contrasts, erase lines and blemishes, and, depending on your artistic skills, make some improvements.

Of course, there are color scanners for the Mac II and IIX. One of the best is the Howtek series. Howtek also makes color printers. Color is clearly the wave of the future. So far, it isn't cheap, but I expect that to change. After all, back in 1976, I more for my original Z80 with 64K bytes of memory than the Mac IIX costs today.

The bottom line is simple: the Macintosh is "good enough." There is sufficient nuts-and-bolts software (i.e., spreadsheets and word processors) to run any type of business. There is also a large number of just plain interesting programs that you're not likely to find on a PC-compatible.

The Macintosh is overpriced, and both hardware and software could use some commonsense improvements. Apple insists on doing odd things, like requiring a useless plastic carrier to be used in the CD-ROM player. Despite all that, the Mac is rapidly becoming indispensable at Chaos Manor. You'll be seeing more about it in my regular column. Meanwhile, it's sure never dull. ■

Jerry Pournelle holds a doctorate in psychology and is a science fiction writer who also earns a comfortable living writing about computers present and future. Jerry welcomes readers' comments and opinions. Send a self-addressed, stamped envelope to Jerry Pournelle, c/o BYTE, One Phoenix Mill Lane, Peterborough, NH 03458. Please put your address on the letter as well as on the envelope. Due to the high volume of letters, Jerry cannot guarantee a personal reply. You can also contact him on BIX as "jerry."

Knowledge, Experience & Expertise your most valuable resources.

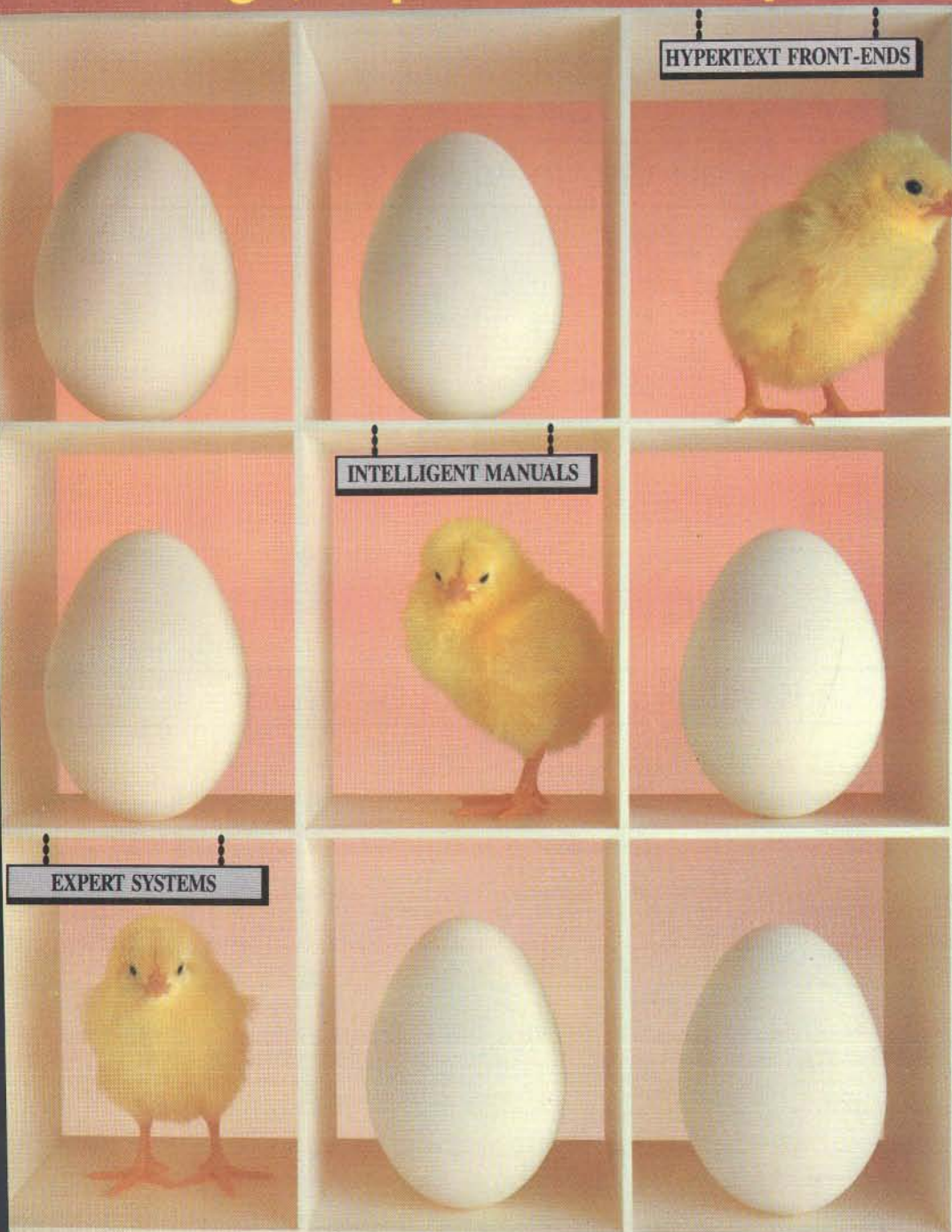

Now available on the IBM PC!

KnowledgePro® is a tool for "explaining things" using a computer. It combines HYPERTEXT and EXPERT SYSTEM technologies in a high-level language to let you write stand-alone applications or add an intelligent, aesthetic interface to your existing programs.

KnowledgePro stores knowledge in natural "chunks" called topics. It lets non-programmers communicate complex information using simple commands like SAY, ASK, IF, DO and PICTURE.

KnowledgePro lets you integrate hypertext, rules, math, lists, and logic quickly and easily. With our Database Toolkit you can read Lotus 123 and dBASE III files. The Graphics Toolkit lets you define hypergraphics using PC Paintbrush images. The VideoDisk Toolkit provides complete control of interactive laser video.

KnowledgePro reads, writes and searches text files. You can include routines written in other languages and call other programs.

our **KnowledgePro** application can ask users for information you need to bring together resources and explanations by need. You can retrieve text, graphics, data, and video information, perform calculations, create text files and run programs based on each user's unique problems, interests and level of expertise. "I recommend that you check out **KnowledgePro**", said Steve Ciarcia of BYTE. "So much fun to work with", said Mickey Williamson in PCWEEK. "I LOVE **KnowledgePro**. It's less like programming and more like living", said Dan Shafer of PC AI.

KnowledgePro runs on IBM PC XT, AT and PS/2 compatibles with 640k. It costs \$495 plus \$8 shipping (\$58 foreign). There are no run-time charges, so you don't have to pay more to distribute applications. The Database, Graphics and VideoDisk Toolkits cost \$49, \$89 and \$249 respectively. **KnowledgeMaker**, our induction system for creating rules from data, costs \$99. **Stock Expert**, a system for the personal investor, costs \$249. A working demonstration system, with a 100 page manual, is available for \$30 plus \$5 shipping (\$8 foreign) with credit toward purchase of the full system.

Circle 143 on Reader Service Card

For product literature, review reprints or to order:
Call 518-766-3000
(FAX 518-766-3003)

MasterCard, M/C, Visa, COD or send check to:
Knowledge Garden Inc., 473A Malden Bridge Rd.
Roseton, NY 12123, USA.
New York residents please add 7% sales tax.

KnowledgePro®
A tool for communicating knowledge
by Bev & Bill Thompson

Join us on CompuServe (GO PCVEN user option #8)

from



Quality In... Quality Out



No matter how well acquainted you are with making important personal computing decisions—decisions that may involve hundreds of thousands of dollars—the value of those decisions is only as good as the value of your information. Without quality information—it's hard to make quality decisions.

BYTEweek, McGraw-Hill's new weekly newsletter for professionals in the personal computer industry, is devoted to giving you that quality information through its timely and compact one-stop news format.

This new publication provides you with short, easy-to-read selections of the most important news and technological developments of the past week. And BYTEweek interprets this news with in-depth commentary and analysis.

Subscribe to BYTEweek for quality information. Remember, quality in...quality out.

Subscribe now and take advantage of the special one-year charter subscription rate of \$395 (\$495 outside the U.S. and Canada). This special price represents a savings of \$100 off the regular rate. Your subscription includes 50 issues plus a free three-month subscription to BIX—a \$49 value. Through BIX you can directly access the Microbytes Daily news service and communicate with other BIX users.

Don't miss this opportunity! In the U.S., call BYTEweek's toll-free number: **1-800-258-5485**, in N.H. and outside the U.S., call: 1-603-924-9281.

BYTEweek offers a *money-back guarantee* if you're not completely satisfied.

BYTEWEEK 

News and Analysis for Professionals in the Personal Computing Industry
One Phoenix Mill Lane, Peterborough, NH 03458

Security

- 257 How Safe Is It?**
by *Martin Kochanski*
- 267 Secret Codes**
by *Asael Dror*
- 275 Know Thy Viral Enemy**
by *Ross M. Greenberg*
- 285 Personal and Private**
by *Peter Stephenson*
- 290 The Safety Zone**

Everybody talks about micro-computer security, but few of us like to use it. We think of it as something difficult and costly. While we probably can't have security without some level of inconvenience, we can understand the issues. While there will be some cost, we can also understand and appreciate that the cost of security is minimal compared to the cost of doing without it.

We are pleased to begin our look at small computer security with "How Safe Is It?" by Martin Kochanski, a leading theorist and designer of encryption and security systems. He gives us a good look at security issues and ways to address them so that they work together with the people who must use them. Another area of major concern is network security, a huge topic which BYTE plans to come back to. But for now, Michael Durr and Mark Gibbs take us through the various levels of LAN security in the accompanying text box "Peeling Back the Layers."

Next, in "Secret Codes," Asael Dror explains how computer cryptography, the Data Encryption Standard (DES), and the RSA standard work. His is one of the clearest explanations of this complex subject that I have seen to date. He shows quite well that the theory of cryptography need not be impenetrable just because the encrypted results are.

Then, Ross M. Greenberg tells us about one of the most discussed security subjects, computer viruses (and related electronic fauna), in his article "Know Thy Viral Enemy." A well-known author of antivirus software, Greenberg

shows us just how insidious these destructive programs can be.

Securing your computer may be worth doing, and it surely helps to know how to go about it. Peter Stephenson, in "Personal and Private," describes some of the many products available for securing your system and its data. In the accompanying text box "The Small Data Center," Bob Brown, a data center manager, tells us how to put all of this together into a coherent program. Coherency, after all, is required if your security program is going to work.

Inconvenient and costly? Sometimes. But computer security is one of those safety features that you don't think about until it's too late. It's an insurance policy you hope you'll never need. While it would be nice to work where you don't need security, most of us never will.

—Wayne Rash Jr.
Consulting Editor

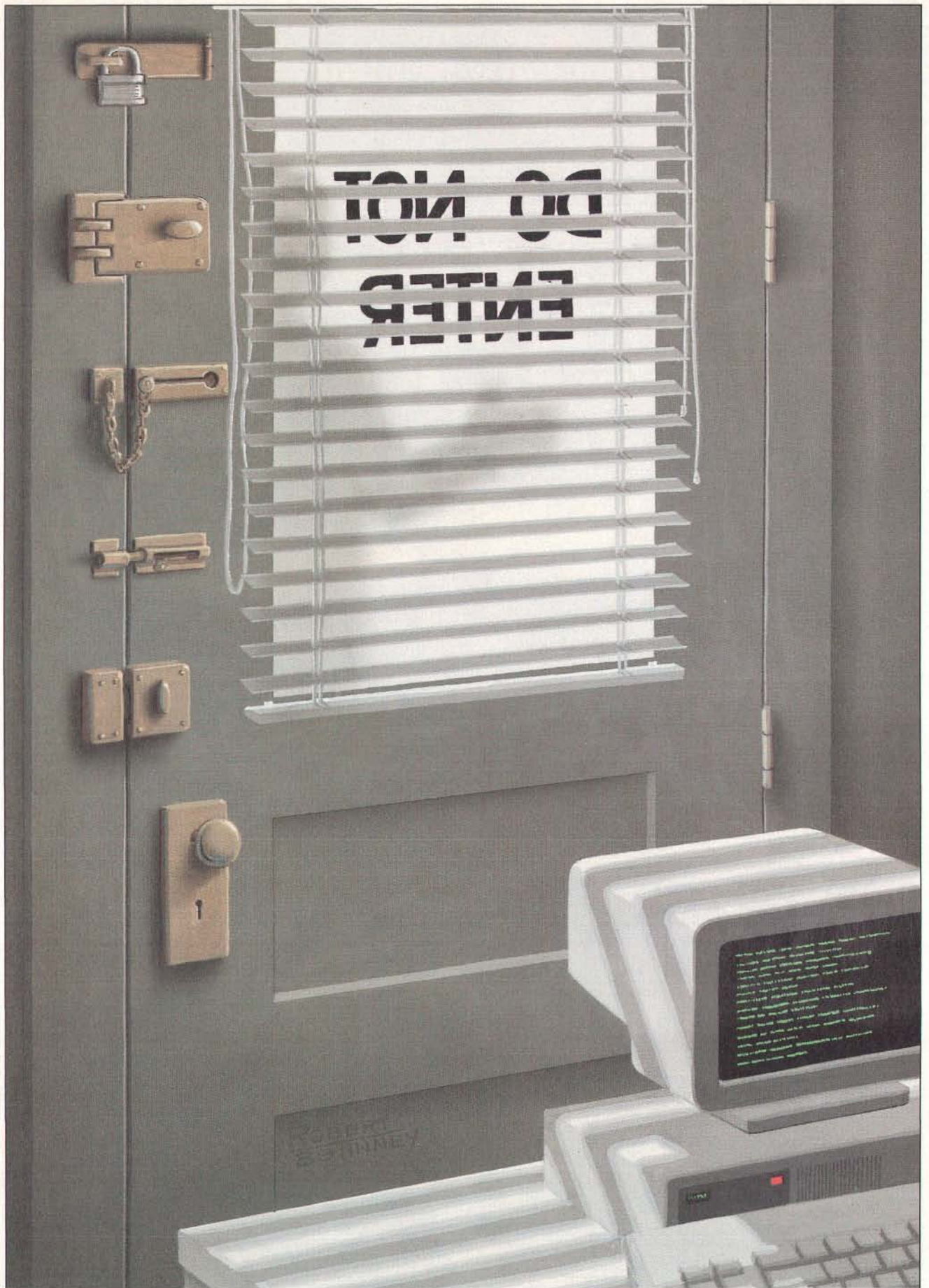

Losing Software Sales?

Protect yourself from software piracy with SecuriKey.

Think about it —

Some experts estimate there are as many as ten illegal copies for every legitimate software package sold. Suppose you sold 1000 copies of a \$500 program, and *only* two copies were pirated for each one sold—*You're out a million bucks!*

Micro Security Systems, Inc. can help you keep your profits with a hardware lock called SecuriKey. SecuriKey has protected major software products in domestic and risky foreign markets for over six years. With eight styles to choose from there is a SecuriKey designed to meet your specific needs.

SecuriKey Features:

- Works on all IBM and compatibles
- Works with LAN and hard disks
- Allows unlimited back up copies
- Passive to printers & other programs
- Easy to install
- Trillions of possible combinations

Call us today— and stop giving your software away.
(800) 456-2587

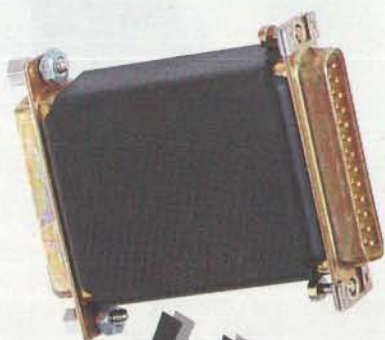

micro
security
systems, inc.

Circle 174 on Reader Service Card
(DEALERS: 175)

Micro Security Systems, Inc.
4750 Wiley Post Way, Suite 180
Salt Lake City, Utah 84116-2878
(801) 575-6600

Copies Stolen



Copies Sold

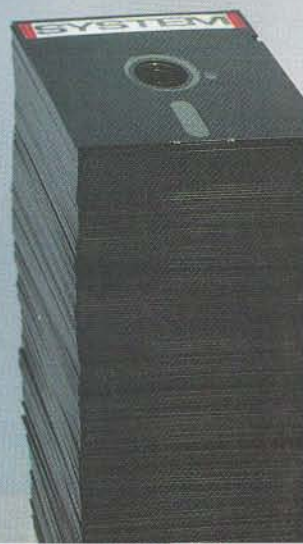

How Safe Is It?

*Absolute security is unattainable, and doing nothing is dangerous.
So how much security is enough?*

Martin Kochanski

No one truly wants personal computer security. Access control, passwords, authorizations, and the procedures needed to enforce them are all part of the old world of mainframes: Microcomputers are about freedom and simplicity, not bureaucracy.

Unfortunately, such an ideal doesn't exist in the real world. As the use of personal computers spreads, more and more sensitive data is stored in them, and more people have the ability to look at and even manipulate that data. However unwanted and inconvenient security measures may be, they are nonetheless necessary.

Since security measures are needed whenever you use a microcomputer for a serious business purpose, the logical place to expect to find security features is in the operating system. It seems scandalous that MS-DOS, for instance, has no data security features at all. Worse still, some alternatives to DOS *appear* to provide security in the form of passwords, but you can alter or remove them with any commercially available disk-utility program. They lead you to *think* you're safe—but you're not. Even OS/2,



which is being touted as the operating system of the future, ignores the question of security, and its very architecture makes remedying this deficiency almost impossible.

In another sense, however, ignoring the problem at the operating-system level is correct, because designing effective security measures is harder than it sounds. It's hard enough to design a sys-

tem that is secure in the conventional sense of being hard to break (and several security systems fail spectacularly in this area), but it's harder still to make a security system so easy to use that people will use it and *continue* to use it without constantly being reminded to do so. For instance, there's no point in having the world's most secure file-encryption program if it takes 5 minutes and 50 keystrokes to encrypt or decrypt a file. The cost in terms of time, inconvenience, and broken trains of thought is too great. Even if they have to use such a program, most people will soon start looking for (and finding) ways to circumvent it.

Access Control

The very mention of data encryption immediately discourages many microcomputer users. "We are not," they rightly argue, "the CIA: Why should we indulge in James Bond methods to protect our sales ledger?" To answer this, I'll look at something less dramatic—a straightforward mainframe-type password system—and examine its effectiveness. I'll assume that the microcomputer being used is a

continued

Peeling Back the Layers

Michael Durr and Mark Gibbs

The basic security model, for a computer, a bank, or any other subject, resembles an onion. Layers of security surround the subject that needs to be secured. Each layer insulates the subject and makes it more difficult to access in any way other than those planned for. Physical security is the outer layer and, in general, consists of locking things away or bolting them to a desk.

With a distributed processing system, the primary physical-security concern is preventing access to the hardware. To defeat all other security measures, you must have physical access to the hardware. This is common to all computer systems, whether distributed or not.

The inner layers of security are concerned with logical security—the methods that cover control of access to the system resources and services. You need to be as concerned about these inner layers as about the physical layers.

Disk Server vs. File Server

In early LANs, the server systems were disk servers; that is, they provided access to disk storage and other services at a hardware level. Each workstation managed the shared hard disk as if it were a dedicated device, communicating via low-level I/O calls. The server wasn't designed to handle anything but the basic data storage blocks. Coordinating file access among workstations was left to the applications accessing the files or to the users themselves. If an unverified write by an unauthorized process occurred to the file allocation table, it was possible that a significant portion, or even all, of the data on the

disk could be lost, for all the users.

The file server is a result of the evolution of LAN technology. The file server provides a much higher level of service to the client workstations than does the disk server. The low-level processes of the server devices are available only through requests to logical devices rather than directly to the physical device. Because of this, the system can be designed for security. In addition, file access can be coordinated and data integrity can be verified.

The file server, as a design concept, is the foundation for all client-server protocol security. Most network operating systems have adopted this approach. The disk server is now obsolete, but it helps illustrate the primary threat to security on distributed systems. Any design that permits someone to get around the security protection in the operating system and directly control the filing system must be considered insecure.

Logical Layers

Logical security has layers that fall into two major groups (see figure A): the access security layers and the service security layers. The ASLs are concerned with controlling availability, verifying identity, and establishing access rights, and are a higher-level function than the SSLs. SSLs are concerned with the availability of and access to the system services.

The highest ASL is the system access layer (SAL). This layer is responsible for determining if and when the network is available on either a system-wide, group, or individual station basis. It

may also be responsible for disconnecting a station on which there is an attempted break-in, as well as providing an activity audit trail. The SAL also carries out supervisor-enforced log-out. The SAL could, for example, prevent log-ins during non-office hours and disconnect all sessions after a certain time.

Below the SAL is the account access layer (AAL). This layer verifies that the user who logs in with a given name and password exists and has a valid user profile.

The innermost layer in the ASL is the access rights layer. When you have passed through the SAL and AAL, the ARL determines what connection privileges you have (e.g., the account can only have sessions that total 4 hours per day, or the account can only use workstation 27). Some of the functions you can implement at the ASL are accounting (for connect time, disk usage, and so on) and user-activity audit trails.

Service Layers

The service security layers (SSLs), which sit below the ASLs, control access to system services, such as queues, disk I/O, and server management. The highest SSL is the service control layer (SCL), which is responsible for advertising services and their status reports. It also enables and disables service operations.

Once the SCL has established a service, the service rights layer (SRL) determines exactly how the account can use the service. For example, an account may only have the right to add jobs to printer number 3 but have full

fairly conventional one, with a hard disk on which sensitive data is stored.

The simplest password system is a program that runs when you boot up, demands a password, and won't let the boot proceed until you enter the correct password. One common method uses a line such as `DEVICE=PASSWORD.SYS` in the `CONFIG.SYS` file to activate it. A scheme this simple has many obvious defects—notably that the computer remains permanently vulnerable once it has been successfully booted. However elaborate a real-life password system may be, it is subject to attack in essentially the same ways as this simple example.

A frontal attack on any password system—even such a simple one—is unlikely to succeed. Repeatedly switching on and attempting to guess passwords is time-consuming, and, unless the choice of password was blindingly obvious, it is also unrewarding.

However, both IBM and Microsoft sell a program that will break into any DOS-based password or access-control system that doesn't use encryption: IBM calls it PC-DOS; Microsoft calls it MS-DOS. Buy the disk; insert it into drive A; start up the machine; and you have access to all the data in the computer. By booting from a floppy disk that has no `CON-`

`FIG.SYS` and no `AUTOEXEC.BAT` file, you circumvent any possible password protection and can examine or alter any file on the hard disk. (If the computer uses nonstandard hardware and special device drivers, it may take a little longer to get at all the files, but it's just as simple.)

The problem with password systems exists because passwords are not a security feature—they are an *insecurity* feature, intended to provide controlled access to an otherwise impregnable system. To use a physical metaphor, a vault with 3-foot-thick steel and concrete walls is (almost) impregnable, but useless; add a

add and delete rights to jobs on printer number 4. The SRL also administers the specific rights of an account. If the account is a member of one or more groups, then the SRL will ensure that the account inherits the group rights. For example, an account may only have read, open, and search file rights in the program subdirectory and operator. The services may include both software-specific high-level service (HLS) and hardware-specific low-level service (LLS) operations.

The HLSes are operations that are not hardware-bound—for instance, a request to open a file by name. Other such services are queues and mail slots. The HLSes are actually built from LLSes and may require several of the lower-level functions to operate. The LLSes are hardware-dependent. These services are the fundamental building blocks of the system and cover disk sector-level I/O and memory-block allocation and deallocation.

A Trusted Connection

As a connection is established, the ASLs validate and define the account. The actual operations to be carried out are controlled by the SSLs, which prevent requests not specified within the user profile. Access in a thoroughly secure system must be through these layers from top (SAL) to bottom (LLS). But when disk servers and other aspects of the system use only the ASLs to control access to the system and then allow you to make requests directly to the LLSes, the layers of the SSL are easily avoided, and unauthorized operations

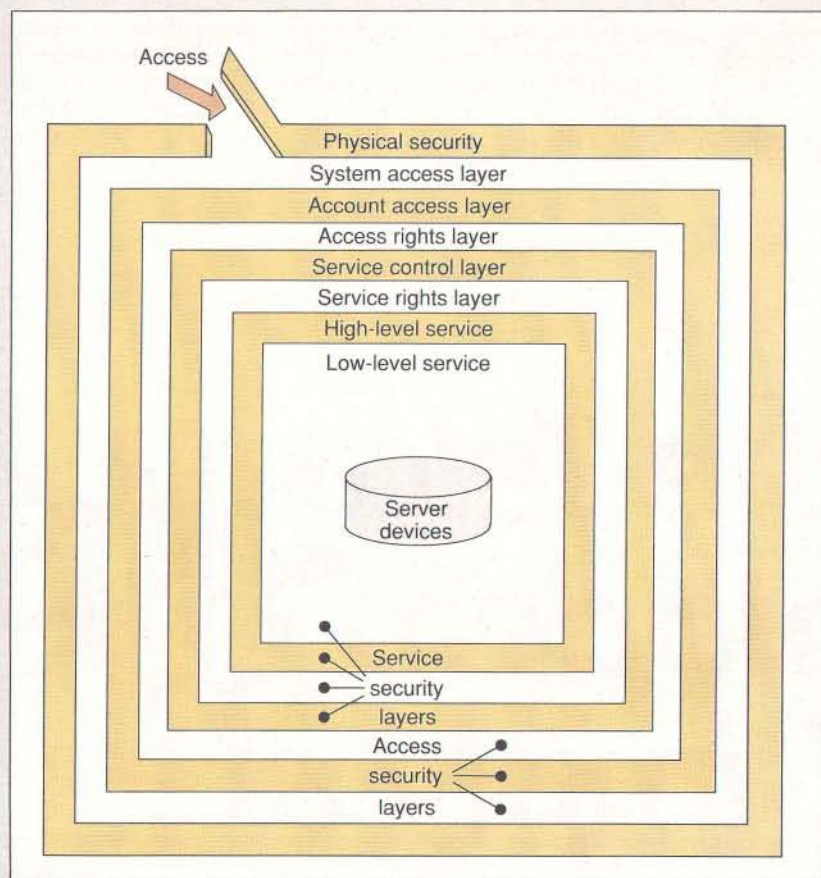

Figure A: Like an onion, good security is composed of layers wrapped on layers. In the file-server model, access to the actual device must go through three layers of access security and four layers of service security.

can be performed without detection. This happens when all the other layers of the SSL are implemented and executed in the disk-server client.

Any system that lets you avoid one or more layers of the model or just leave them unused runs the risk of being insecure.

Michael Durr works for Novell (Provo, UT) in corporate marketing. He is based in Los Angeles, California. Mark Gibbs also works for Novell in corporate marketing and is based in London, England. They can be reached on BIX c/o "editors."

door, and access becomes possible; add a lock to the door, and you have *controlled* access. Mainframes are inaccessible, air-conditioned, and often surrounded by white-coated acolytes; passwords provide controlled passage through all this security. Microcomputers are in the office, physically accessible, and sometimes even portable. Adding passwords is like building a strong door with a secure lock on a house made of playing cards.

Access *restriction* is a prerequisite for access *control*. Access restriction can take several forms. It can be *physical*, as when you keep a computer locked away in a separate room; in this case, you don't

need any additional hardware or software security measures.

It can be *inherent*, as when a computer is of such an unusual kind, or so hard to operate, that you can't figure out how to do anything harmful even if you do have access. Many companies still rely on this kind of protection. It worked well in the past, when there were few microcomputers around and few people knew how to use them, but it's not as safe now.

The access restriction can be *logical*, imposed by the hardware or software and making access impossible without special programs or knowledge. Encryption provides the simplest way of doing this.

Using encrypted data with a decryption program may sound like using a password system—it even looks similar to the user, who may not appreciate the distinction between a password and a decryption key—but it's not. If you bypass or disable the password system, everything is accessible; but even if you circumvent the decryption program, you still can't read anything.

One more point worth noting when considering encryption: It's not really the computer you need to secure, it's the data. Even if you consider the locked-room approach adequate to protect the

continued

computer—and using keylocks or PS/2-type power-on passwords is essentially a variant of this approach—the data exists not only on the computer but on many backups in different places.

To ensure data security, you must consider not only preventing unauthorized access but also not losing data. Preventing unauthorized access is best achieved by having no backups at all; preventing data loss requires as many backups as possible. Encryption can resolve this

fundamental contradiction simply and effectively. If backup disks are securely encrypted, you can make unlimited numbers of them without compromising confidential data. Thus, even if you don't use encryption directly in daily operations, you may want to use it on backups.

Transparent Encryption

The simplest way to implement encryption on a microcomputer is with an encryption and decryption program. On

command, this will encrypt or decrypt a specified file with a specified password. Such programs are simple to write but impractical to use. For example, to edit a previously encrypted sensitive document during a typical word processing session, you must

- exit the word processor;
- call up the decryption program, specify the filename and appropriate encryption key, and wait for the whole file to be decrypted;
- reenter the word processor;
- edit the document;
- exit the word processor;
- call up the encryption program, specify the filename and appropriate encryption key, and wait for the whole file to be encrypted; and
- reenter the word processor.

In addition, you must overwrite any temporary or backup files that the word processor may have created. If it created and deleted any temporary files itself, you must overwrite all the free space on the disk in case sensitive data was left there.

One refinement of such encrypt-on-demand programs is to make them permanently resident, activated by a single keystroke. This removes the "exit word processor" and "reenter word processor" steps, but otherwise leaves the procedure as awkward as before. Faced with frequent amendments to a document, normal human impatience will dictate leaving the document file unencrypted just in case another change is needed.

A further weakness of these schemes is their use of keys. You have to enter encryption and decryption keys frequently, so many people will select short—and thus insecure—keys for ease and speed of typing. Also, there is no built-in protection against misspelling. Suppose that the key CONFIDENTIAL (obvious and thus insecure) is misspelled as COMFIDENTIAL. Everything seems all right until you try to access the document, perhaps months later, and find it to be unreadable.

Transparent encryption solves these problems. A transparent encryption system is a TSR program that remains permanently active. It monitors and intercepts all disk accesses for sensitive files. Whenever records are written, the encryption system encrypts them before they reach the disk; whenever records are read, it decrypts them before they reach the application programs.

A transparent encryption system is *continued*

the Telcor modem "simply ate up our data."

38.4K
bps



Our patented Model 2496 data compressing modem was the only 2400 bps unit included in this evaluation of 9600 bps dial modems. And it was judged the surprise of the lot!

Just imagine what our 9600 bps modem can do . . . dial data throughput up to 38,400 bps. What's more, the Telcor Model 2938 also talks to 300, 1200 and 2400 bps modems and fully supports MNP Levels 2-6.

The Telcor Model 2938 outperforms any other dial modem in the world. If

John H. Humphrey and Gary S. Smock
High Speed Modems
June 1988, Byte Magazine

you find that hard to believe, prove it to yourself. Order a pair at \$1195 apiece and try them for thirty days. High speed file transfer software for your PC-AT is included.

Call us toll free in the U.S. at 1-800-826-2938. Elsewhere call 1-508-653-3995. VISA and Mastercard accepted. Also available through local distributors.



the world's fastest
dial modems

ESTABLISHED
1968

MONTGOMERY GRANT

OUTSIDE USA.....CALL
(718)692-0071

For Customer Service
Call Mon-Fri: 9:30am-4:30pm
(718) 692-1148

Retail Outlet Penn Station Main Campus
(Beneath Madison Square Garden)

Store Hours: Mon-Thu: 9:30am-6pm Fri: 9:30am-5pm Sat: 10am-5pm

FOR ORDERS & INFORMATION CALL
1-800-759-6333

ORDER HOURS: Monday-Thursday, 9:00am-7:00pm; Friday, 9:00am-6:00pm; Saturday, 10:00am-5:00pm
NO SURCHARGE FOR CREDIT CARD ORDERS. WE INVITE YOU TO VISIT OUR STORE.
CORPORATE LEASING AVAILABLE

LAPTOPS

AMSTRAD PPC-640 w/Two Drives & 2400 Baud Modem.....	\$769
TOSHIBA 1600.....	\$3269
TOSHIBA 3100 e.....	\$2759
TOSHIBA 1000.....	\$749
TOSHIBA 1200 H.....	\$2199
TOSHIBA 1200 HB.....	\$2399
TOSHIBA 3200.....	\$3549
TOSHIBA 5100.....	\$4599
NEC MULTISPEED H.D.....	\$1999
NEC ULTRALITE 1MB.....	\$1899
NEC ULTRALITE 2MB.....	\$2299
NEC PROSPEED 386 w/40MB.....	\$4599
ZENITH 184 w/TWO FLOPPIES.....	\$1469
ZENITH 184-2 w/20MB.....	\$2199
ZENITH 286 w/20MB.....	\$3099
SPARK EL.....	\$999
COMPAQ SLT 286-20.....	\$3899
QUADRAM J.T. FAX FOR LAPTOPS.....	\$259

MODEMS, EXTERNAL DRIVES & ACCESSORIES
AVAILABLE FOR ALL LAPTOPS



EPSON EQUITY 1+
IBM XT COMPAT. PKG.

- 640K RAM w/Clock Calendar
- 360K Drive
- Keyboard
- Serial and Parallel Ports
- 12" High Resolution Monitor
- MS DOS / GW Basic

\$799

SAME W/20MB HARD DRIVE.....\$1059
SAME W/30MB HARD DRIVE.....\$1099
SAME W/40MB HARD DRIVE.....\$1149
SAME W/TWO 360K FLOPPIES.....\$879

EPSON EQUITY 1e.....CALL!



EPSON EQUITY II+
IBM AT COMPATIBLE
HARD DRIVE PACKAGE

- Keyboard
- 640K RAM
- 80286 Microprocessor
- 1.2MB Floppy Drive
- 20MB Hard Drive
- 12" Monitor
- MS DOS/GW Basic

\$1499

SAME W/30MB HARD DRIVE.....\$1549
SAME W/40MB HARD DRIVE.....\$1599

FINAL
EPSON PRICES!
NO WAIT FOR
REBATE!

AMIGA **NEW**

AMIGA 500 w/Built-in 5.25" Drive	\$529
AMIGA 500 w/1084S Monitor	\$799
AMIGA 2000 w/Built-in 3.5" Drive	\$1359
AMIGA 2500	\$3149
AMIGA 2000 H.D.	\$1999
AMIGA 1084S RGB MONITOR.....	\$279.95
AMIGA 1010 DISK DRIVE.....	\$149.95

**ALL AMIGA PERIPHERALS AND
ACCESSORIES IN STOCK!!**

commodore COLT
IBM XT COMPATIBLE
PACKAGE

- Keyboard
- 640K RAM
- Two 360K Floppies
- Serial & Parallel Ports
- 12" Monitor
- MS DOS/GW Basic

\$599

WE RECONFIGURE ANY PC TO YOUR
CALL FOR INFORMATION IN WE CAN
CALL 1-800-759-6333

PRINTERS

STAR	EPSON
NX-1000.....\$169.95	FX-1050.....\$489.95
NX-1000.....\$219.95	FX-850.....\$339.95
RAINBOW.....\$299.95	LQ-500.....\$299.95
NX-2400.....\$299.95	LQ-850.....\$529.95
CITIZEN	LQ-950.....\$589.95
MSP-15E.....\$329.95	LQ-1050.....\$729.95
MSP-40.....\$289.95	LQ-2550.....\$919.95
MSP-45.....\$369.95	LX-800.....\$179.95
MSP-50.....\$349.95	FX-286E.....\$409.95
Tribute-124.....\$389.95	
Tribute-224.....\$589.95	

SHARP PC-7100A PORTABLE
IBM XT COMPATIBLE COMPUTER PKG.

- Detachable Keyboard
- Backlit Screen
- 8 MHz, Turbospeed
- 5.25" Floppy Drive
- 20MB Hard Drive
- Serial/Parallel Ports

\$1099

PC 7000A2
w/2 Floppies.....\$788

AST BRAVO 286
HARD DRIVE PKG.

- 80286 Processor
- 1.2MB Floppy Drive
- 20MB Hard Drive
- Keyboard
- 12" Monitor
- Video Card

\$1249

SAME PACKAGE W/30MB.....\$1349
SAME PACKAGE W/40MB.....\$1399

AST PREMIUM 286
MODEL 70
HARD DRIVE PKG.

- 80286 Processor
- Keyboard
- 1.2MB Floppy Drive
- 20MB Hard Drive
- 12" Monitor
- MS DOS/GW Basic

\$1499

SAME PACKAGE W/30MB.....\$1549
SAME PACKAGE W/40MB.....\$1599

**SEAGATE 20, 30, 40, 60,
80MB HARD DRIVES IN
STOCK!**

OKIDATA

OKIMATE 20.....\$139.95	KXP-1124.....\$319.95
OKIDATA 180.....\$299.95	KXP-1180.....\$189.95
OKIDATA 320.....\$349.95	KXP-1191.....\$239.95
OKIDATA 321.....\$459.95	KXP-3131.....\$319.95

SANYO PR-3000A DAISY WHEEL.....\$59.95
BROTHER HP-20.....\$329
IBM COLORJET.....\$399.95
HP DESKJET PRINTER.....\$679
HP PAINTJET PRINTER.....\$1099

LASER PRINTERS

**HP HEWLETT LASERJET SERIES II
PACKARD \$1629**

1 MB EXPANDER.....	\$349
2MB EXPANDER FOR LASERJET II.....	\$749
HP LASERJET IID.....	\$2829
SPECIAL! PANASONIC KXP-4450.....	\$1399
BROTHER HL-8E.....	\$1859
NEC LC 860+.....	\$1999

**NEC POWERMATE 1
HARD DRIVE PKG.**

- 640K
- Keyboard
- 10 MHz
- 1.2MB Floppy Drive
- 20MB Hard Drive
- Serial/Parallel Ports
- 12" Monitor
- 80286 Processor

\$1499

SAME W/30MB.....\$1549
SAME W/40MB.....\$1599

POWERMATE 386 SX

- 2MB RAM
- 16 MHz
- 1.2MB Floppy Drive
- 42MB Hard Drive
- 12" Monitor
- Windows 386
- MS DOS 3.3

\$2799

POWERMATE 386-20

- 2MB RAM
- 20 MHz
- 42MB Hard Drive
- 1.2MB Floppy Drive
- 12" Monitor
- Windows 386
- MS DOS 3.3

\$3899

commodore PC10-1
IBM XT COMPAT. PKG.

- 512K RAM
- 360K Floppy Drive
- 12" Monitor
- Serial & Parallel Ports
- Keyboard
- Box of 10 Diskettes

\$499

IBM XT HARD DRIVE PKG.

- IBM XT Computer
- IBM Keyboard
- 256K RAM
- Expandable to 640K
- 360K Disk Drive
- 20MB Hard Drive
- Pkg. of 10 Diskettes (Monitor Optional)

\$1099

IBM AT HARD DRIVE PKG.

- 1.2MB Floppy Drive
- 20MB Hard Drive
- Serial/Parallel Ports
- Keyboard
- (Monitor Optional)

\$1599

IBM AT w/30MB.....\$1649
IBM AT w/40MB.....\$1699

PERSONAL SYSTEM 2

PS/II MODEL 25 Color.....	\$1099
PS/II MODEL 30 w/20MB.....	\$1699
PS/II MODEL 30/286-021.....	\$1899
PS/II MODEL 50Z w/30MB.....	\$2749
PS/II MODEL 50-061.....	\$2999
PS/II MODEL 55.....	CALL
PS/II MODEL 70-E61.....	\$3795
PS/II MODEL 70-121.....	\$5299
PS/II MODEL 80-071.....	\$4799

5.25" 360K External Drive for IBM PS/II-30.....\$129
PACIFIC RIM 5.25" 1.2MB External Drive for IBM PS/II 50/60/70/80.....\$259
ALL OTHER PS/II MODELS AVAILABLE

IBM PERSONAL SYSTEM II MONITORS

8503 MONOCHROME.....	\$239
8512 COLOR.....	\$449
8513 COLOR.....	\$539

**LEADING EDGE MODEL D,
MODEL D2, MODEL D3-
CALL FOR LOWEST PRICE!**

AMSTRAD PC-1640

- Keyboard
- 640K RAM Turbospeed
- Two 360K Drives
- 12" Monitor
- FREE Mouse & Software
- MS DOS/GW Basic

\$729

W/ONE FLOPPY AND 20MB.....\$1029
EGA AND CGA MODELS IN STOCK!!

COMPAQ DESKPRO 286

- 640K
- 16MHz
- 1.2MB Floppy Drive
- 20MB Hard Drive
- 12" Monitor

\$1999

SAME PACKAGE W/30MB.....\$2049
SAME PACKAGE W/40MB.....\$2099

COMPAQ DESKPRO 386 S

- 1MB RAM
- 16 MHz
- 1.2MB Floppy Drive
- 40MB Hard Drive
- VGA Adaptor
- 12" VGA Monitor

\$2999

COMPAQ DESKPRO 386-20e

- 1MBRAM
- 20MHz
- 1.2MB Floppy Drive
- 40MB Hard Drive
- VGA Adaptor
- 12" VGA Monitor

\$4199

COMPAQ 386/25 MODEL 60.....\$5895

MAGNAVOX EGA Monitor.....	\$339
MAGNAVOX EGA Monitor w/EGA Card.....	\$459
MAGNAVOX VGA Monitor.....	\$399
MAGNAVOX VGA Monitor w/VGA Card.....	\$509
NEC MULTISYNC II.....	\$579
NEC MULTISYNC IIA.....	\$529
PARADISE VIDEO CARDS.....	IN STOCK!

APPLE PACKAGES
APPLE IIC+ w/Floppy Drive & 12" Monitor
\$599

APPLE IIGS COMPUTER PACKAGE

- Apple IIGS Computer
- 512K Upgrade
- RGB Color Monitor
- Apple 3.5" Disk Drive

\$1499

IMAGewriter II PRINTER.....\$449
MAC SE COMPUTER W/DUAL DRIVE.....\$2299
MAC SE COMPUTER W/20MB.....\$2749
APPLE MAC II.....\$3499
APPLE MAC II W/40MB.....\$4299
APPLE MAC+.....\$1399
APPLE MAC IIX.....\$4799

VENDEX HEADSTART III

- 8-12 MHz
- 1MB RAM
- 5.25" 1.2MB Floppy
- 3.5" 1.44MB Floppy
- 30MB Hard Drive
- VGA/EGA/CGA/MDA
- Includded
- Serial/Parallel Ports
- Mouse
- MS DOS
- 12" VGA Monitor

\$2399

\$1000 SOFTWARE INCLUDED

RUSH SERVICE AVAILABLE. CALL FOR DETAILS.

AMERICAN EXPRESS, VISA, MASTERCARD, DISCOVER, GIFT CERTIFICATE

invisible to the application program, which is unaware that any encryption is going on: This eliminates any possible compatibility problems. Also, full protection automatically extends to temporary files that the application may create and delete without your direct knowledge.

Transparent encryption is almost invisible to the user, too. Encryption keys are set up once and for all at the start of each session and remain buried (suitably encrypted and concealed) in the TSR

program's private memory. Thus, after an initial log-in, the complex sequence of operations necessary to edit a confidential document with simple encryption systems becomes simply "edit the document."

Because you enter the keys only once, there is less user resistance to making them complex and obscure, and you can solve the traditional problem of choosing short, memorable, easily guessed passwords by requiring that keys have a cer-

tain minimum length (e.g., eight characters) and a high maximum length (60 characters or so).

With transparent encryption, entering a wrong key has no catastrophic effect on what is already stored. All that happens is that whatever you read from the disk with the wrong key *appears* to be corrupted: Once you enter the correct key, everything is readable once more.

A final major advantage of transparent encryption is its efficiency in database applications. Instead of having to decrypt and then re-encrypt a whole database—possibly several megabytes in size—whenever a record is required, a transparent encryption system decrypts only the data you actually need: probably an index entry or two, a few pointers, and the required record itself. The resultant increase in speed makes all the difference in terms of practicality.

The things to look for in a transparent encryption system are speed, granularity, transferability, and security. Speed is an obvious necessity. If encryption or decryption takes too long, the computer will appear slow and unresponsive.

Granularity refers to the degree of detail you can use in specifying encryption keys. Encrypt-on-demand systems can easily accommodate file-level granularity, with a different key for every file if necessary; transparent encryption systems have more difficulty doing this. Disk-level granularity—with everything on a disk encrypted identically—is easy to achieve, but it's not enough.

On a bootable hard disk, some files, such as CONFIG.SYS and device drivers (and of course the encryption program itself), must be read before you can install any encryption program, so at the very least there should be a distinction between unencrypted files used in the boot process and encrypted files used thereafter. Moreover, different people may use the computer for different projects, and it's a good idea to enforce separation by using different keys. A usable transparent encryption program must offer at least directory-level and preferably file-level granularity.

Transferability is often overlooked. You will always need to be able to exchange files between computers. This means that you must be able to accommodate different keys, unless everyone uses the same keys. At least one commercial package generates a key randomly at each installation, making piracy the only practical way of ensuring freedom of interchange.

Security is the most difficult criterion
continued

HOW DO YOU GET A JOB WITHOUT EXPERIENCE? AND HOW DO YOU GET EXPERIENCE WITHOUT A JOB?

Most young people have one answer to this problem. They avoid it until they're out of college. But they could be getting solid work experience while they're still in college. With your company's help. And ours.

We're Co-op Education. A nationwide program that helps college students get real jobs for real pay, while they're getting an education.

But we can't do it without you.

Those real jobs have to come from real companies. Like yours.

For more information on how you can participate in this valuable program, write Co-op Education, Box 775E, Boston, MA 02115.

Not only will you be giving students a chance to earn money and pick up the most valuable kind of knowledge, you'll be giving yourselves a chance to pick up the most valuable kind of employee.

Co-op Education.

You earn a future when you earn a degree.



A Public Service of This Publication ©1987 National Commission for Cooperative Education

The #1 Distributors In Europe & The Rim Now Sell The #1 Software Protection In The World.



Software developers creating the latest applications for IBM PC/XT/ATs or compatibles can now turn to local distributors for the *first-class* in *world-class* software protection.

Rainbow Technologies' Software Sentinel™ family of hardware keys is protecting over \$1 billion in personal computer software. Right now. Worldwide. With virtually unbreakable security.

The hardware key concept is simple and effective. Developers incorporate unique codes in their software program which interact with the Sentinel key. The key is shipped with the program and must be connected to the PC in order for the software to run. It's that easy.

Choose Rainbow's SentinelPro™ for most applications or the Sentinel-C for custom configurations. Each model assures the developer that only *holders of the key* can run the software. Without adversely affecting the operation of protected or unprotected programs.

No matter where you sell your software worldwide, stay in control of your distribution and revenue by choosing the internationally accepted standard in protection. For additional information, contact Rainbow Technologies Ltd. in the U.K. or one of the European or Pacific Rim distributors listed below.

SentinelPro™

- Runs under DOS, OS/2 and Xenix, on IBM PC/XT, AT, PS/2 and compatibles, and Atari ST
- Algorithm technique (Never a fixed response)
- Parallel port version
- Minimal implementation effort
- Higher level language interfaces included
- 100 times faster than fixed-response devices (1 ms)
- ASIC design for reliability
- Evaluation kits are available

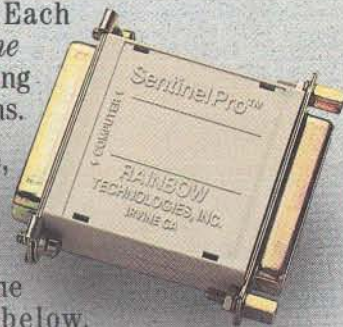

Sentinel-C

- Protects multiple packages with one device
- 126 bytes of non-volatile memory programmed before shipment of the software
- Rainbow supplies the developer a unique adapter for programming the unit
- Higher level language interfaces included
- Runs under DOS, OS/2 and Xenix, on IBM PC/XT/AT, PS/2 and compatibles
- Parallel port version
- Evaluation kits are available

EUROPE

- **FRANCE**
Kontron Electronique
Vélizy Villacoublay (Paris)
tel: (33) 1 3946 9722
fax: (33) 1 3946 0240
- **BENELUX**
IntroCom Electronica
Hengelo, The Netherlands
tel: (31) 74 430 105
fax: (31) 74 429 895
- **WEST GERMANY**
Kontron Datasystems GmbH
Eching (Munich)
tel: (49) 81 65 707-0
fax: (49) 81 65 707 113
- **SPAIN**
MECCO
Barcelona
tel: (34) 3 422 7700
fax: (34) 3 432 2847
- **ITALY**
BFI.IBEXSA SPA
Milan
tel: (39) 2 331 00535
fax: (39) 2 349 2344

- **SWITZERLAND**
IBV AG
Birmensdorf (Zurich)
tel: (41) 1 737 0176
fax: (41) 1 737 1832

- **SCANDINAVIA**
PERICO A/S
Oslo, Norway
tel: (47) 2 491500
fax: (47) 2 397064

PACIFIC RIM

- **AUSTRALIA AND NEW ZEALAND**
PMS Pty. Ltd.
Melbourne
tel: (61) 3 698 9899
fax: (61) 3 699 7501
- **CHINA**
Beta Trading
Hong Kong
tel: (85) 2 5 448963
fax: (85) 2 5 459173
- **JAPAN**
Giken Shoji Co., Ltd.
Nagoya
tel: (81) 52 251 4721
fax: (81) 52 251 0229

Call Today For More Information.
DISTRIBUTOR INQUIRIES WELCOME.



RAINBOW TECHNOLOGIES, LTD.

Shirley Lodge, 470 London Rd., Slough, Berkshire, SL3 8QY U.K. Tel: 0753-41512 Fax: 0753-43610
USA: Rainbow Technologies, Inc., 18011-A Mitchell South, Irvine, CA 92714 • (714) 261-0228 • TELEX: 386078 • FAX: (714) 261-0260

©Copyright 1989 Rainbow Technologies, Inc. All product names are trademarks of their respective manufacturers.

Circle 239 on Reader Service Card
(DEALERS: 240)

of all. Too many vendors of security systems underestimate the subtleties, intricacies, and pitfalls of cryptography and publish products that are dangerously insecure, many of which can be broken in a few hours with no specialized cryptographic knowledge. Unfortunately, the encryption algorithm seems to be the last thing considered in designing most security systems. In evaluating a number of security systems, I have found that some use trivial algorithms, misapply them (e.g., use random-number generators for cryptographic purposes), or use stream ciphers, which are intended for use *once only* in data transmission, to repeatedly encrypt blocks of data.

The most dangerous thing about such mistakes is that they are completely invisible to the user who has no cryptographic expertise. You notice if your word processor prints nonsense or your database retrieves the wrong data. But in a security system, all you can do is check that your files continue to be readable after being encrypted and decrypted. Beyond that, you can only hope that your system is truly secure.

Even the respectability of the vendor doesn't appear to be a good guide to the security of its systems. One international accounting firm promoted a data security product whose disks you could decrypt in the time it took to physically read and rewrite them. When confronted with this fact, the firm claimed that the encryption algorithm was "only a part" of the complete system. Indeed it is, but it's an indispensable part. The foundations may be only a part of a building, but without them, the building will crumble.

Standards and Validation

Traditionally, areas of functionality where you are unable to form judgments for yourself are covered by standards, and it might be reasonable to expect this to happen with encryption algorithms. There does indeed exist a U.S. Data Encryption Standard (DES), along with an array of ancillary standards describing how to use it in a variety of contexts.

Unfortunately, the DES is a hardware standard rather than a software standard. It relies heavily on bit manipulation and thus runs slowly in software: It is hard to exceed 100,000 bps even on the fastest IBM PS/2. Moreover, DES is a stream cipher with a small block size (8 bytes), intended for data transmission rather than data storage, so it's not prudent to use it for transparent data security.

DES is over 10 years old, but it's unlikely that any replacement standard will appear, especially one more suited to

data storage than to data transmission. Standards consolidate progress, but they also hamper further development.

When DES was originally designed, there was an overwhelming need for standardization in hardware, because of the size of the investment required to design encryption chips and because data communications (the principal application) required that the same encryption algorithm be used at both ends of a link. But with software, especially software designed mostly for local operation on a single microcomputer, the investment is smaller and there is less need for uniformity, so the expense and inconvenience of a single standard cannot be justified.

It has also been suggested that there should be some sort of central body whose duty it is to evaluate encryption algorithms and report on their security. Unfortunately, this is impossible. First, security is not a matter of testable fact (except for the most obviously insecure algorithms, whose insecurity can readily be demonstrated). Experience and opinion must play a part in the evaluation, and it is difficult to find someone who has adequate expertise and is not hampered by a conflict of interest.

Short of employing an expert of your own (and trusting that his or her expertise is as great as he or she claims), if you must evaluate encryption packages, you have to cut through the verbiage and sales literature, ask awkward questions about who actually wrote or evaluated the encryption algorithm, and then decide whom to trust—an unenviable task.

Network Security

LANs appear to be more difficult to protect than microcomputers, because access to data is possible from a wider area. This additional difficulty is, however, mostly illusory. Because data on a LAN is typically held on a server machine, physically securing the server takes care of physical data security, and conventional passwords and access profiles become more effective. (See the text box "Peeling Back the Layers" on page 258.) However, you are effectively tied to a particular LAN vendor's offering in its entirety, and awkward trade-offs can arise between security and performance: trade-offs that may not be apparent at first but become more significant as the network grows and you are less sure about the trustworthiness of its users.

Physical interception of LAN messages can become a problem on larger networks. Network analyzers can be used not for their legitimate purpose of identifying and correcting network prob-

lems, but to intercept sensitive data. The need to protect LANs against attacks of this kind (and against straightforward decoding of stray radio emissions) is only gradually being realized.

Wide-area networks, along with simpler forms of data and message transmission, have different problems. In principle, you can use many elaborate security protocols to verify the identity of the participants in a dialogue and to secure data against interception or alteration. In practice, complacency leads to a total lack of precautions, and compatibility considerations mean that straightforward "dumb-terminal" protocols (with little or no scope for data security) are used even when there is considerable CPU power present at both ends of a link. Incidents such as the Internet worm may serve to alert people to the need to take reasonable precautions, but this multi-vendor situation is one in which we must make a strong effort toward standardization if we expect to make any progress.

Appropriate Security

Absolute security is unattainable. Very high degrees of security are commercially available, but they can be inappropriate. When evaluating various approaches, consider how much security you really need. In many cases, a simple power-on password (in either hardware or software) is sufficient. While it can be fairly easily circumvented by anyone who knows how, that in itself may be an advantage, since you needn't worry too much if the password is forgotten (full-blown security systems have elaborate procedures to allow recovery from lost passwords). You may judge that the kind of attackers you have to protect against wouldn't have the technical competence to circumvent even quite simple protection measures—or wouldn't have the patience to try.

Whatever your situation, it's important to evaluate risk. If the risk is mainly from outsiders, then encryption and physical-access control may be most useful; if it's from insiders, then audit trails can be a powerful tool. It's useful to compare data with backups. Doing nothing is dangerous, but an over-elaborate protection scheme is equally irresponsible, because no one will use it. Complacency and panic are equally harmful: A reasoned assessment is essential. ■

Martin Kochanski is a director of Business Simulations Ltd. in London, a firm specializing in information retrieval and data security. He can be reached on BIX as "mjk."

**NOW! Larger Data Sets.
Upgrades Available**

MODEL FITTING RESULTS FOR: YIELD

INDEPENDENT VARIABLE	COEFFICIENT	STD. ERROR	T-VALUE	SIG. LEVEL
CONSTANT				0.0018
time	-3977.847583	747.932209	-5.3185	0.0016
time^2	17.862499	3.288094	5.4325	0.0386
temp	-0.021469	0.008156	-2.6386	
temp^2	44.997502	9.614533	4.6802	
time*temp	-0.124651	0.032546	-3.8500	
	-0.0975	0.020297	-4.8037	

MAE = 1.173868
0.000000
SE = 2.029674
0.000000

R-SQ. (ADJ.) = 0.7865
Previously: 0.0000
12 observations fitted, forecast(s) computed for 0 missing val. of dep

FURTHER ANOVA FOR VARIABLES IN THE ORDER

SOURCE	SUM OF SQUARES	DF	MEAN SQ.	F
time	15.3890909	1	15.389091	
time^2	15.6011921	1	15.601192	
temp	1.0765657	1	1.076566	
temp^2	60.4298606	1	60.429861	
time*temp	95.0625000	1	95.062500	
Model	187.559209	5		

CHEMICAL YIELD AS A FUNCTION OF TIME AND TEMPERATURE
(POINTS REPRESENT ACTUAL OBSERVATIONS)

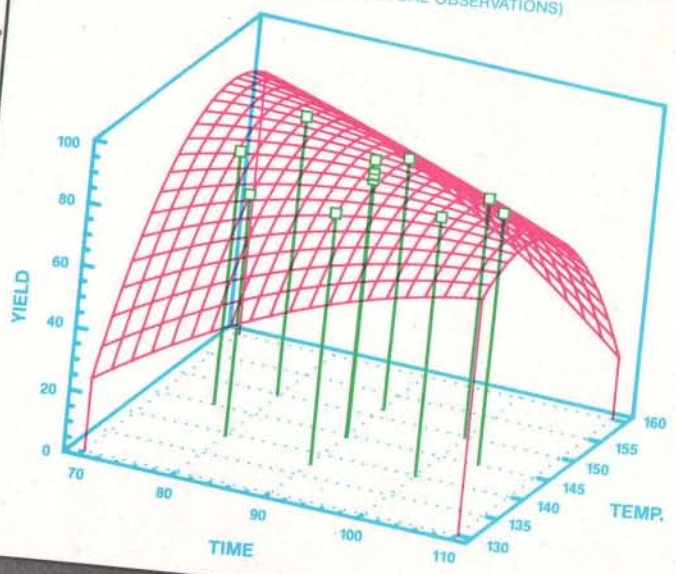

BRAINS & BEAUTY

STATGRAPHICS®. Sophisticated Data Analysis and Gorgeous Graphics — In An Easy-to-Use PC Statistics Package.

Get the best of both worlds with STATGRAPHICS — sophisticated data analysis *and* a dazzling array of graphics in an easy-to-use PC statistics package.

Powerful Statistics. Realize the full potential of your analytical skills. STATGRAPHICS gives you over 250 statistical procedures including ANOVA, regression analysis, quality control procedures, experimental design, multivariate techniques, nonparametric methods, exploratory data analysis, forecasting, time series analysis, and more.

Incredible Graphics. Turn the "Ho-Hum" into the "Ah-Ha!" STATGRAPHICS includes over 50 types of graphs that allow you to analyze your data visually and communicate your results brilliantly!

Easy To Learn and Use. Enter your data using our full-screen editor, or import data directly from your ASCII, dBASE®, Lotus®, or DIF files. STATGRAPHICS is completely menu-driven and includes online HELP, a self-paced tutorial,

handy reference cards, and a user's guide complete with examples and sample data sets. No wonder *InfoWorld* said STATGRAPHICS "makes interactive data analysis and knock-your-socks-off graphics easy."

Why compromise? Get the power of sophisticated data analysis *and* gorgeous graphics with STATGRAPHICS — all for only \$895.* For more details or to order today, call:

(800) 592-0050 ext. 400
In Maryland, (301) 984-5123;
Outside the U.S., (301) 984-5412 for the name of the dealer nearest you.

Ask about our money-back guarantee!



STSC STSC, Inc.
2115 East Jefferson Street
Rockville, MD 20852
Circle 260 on Reader Service Card

*Suggested retail price in U.S. and Canada. International prices vary. STATGRAPHICS, dBASE, and Lotus are registered trademarks of Statistical Graphics Corp., Ashton-Tate, and Lotus Development Corp., respectively.

NEW UPDATE — Extended VGA Support



The Graphics Toolkit for Contemporary Software Developers

Already the fastest and most powerful graphics toolkit on the market, the new HALO® delivers subroutines and device support for exciting, contemporary applications in publishing, office automation, vision, and image processing.

HALO '88 is a device independent library of 190 graphics subroutines. It is compatible with 18 programming languages, and over 140 hardware devices such as image scanners; graphics, vision, and imaging boards; printers and plotters; and mice. HALO '88 is designed for the complete IBM compatible microcomputer line including the PS/2 and VGA.

Today's Tools for Tomorrow's Applications

HALO '88 has new subroutines which control scanners and scanned images — even images which are larger than screen resolution and available memory. Extended character set support enables software developers to address IBM's

full 255 characters in graphics and to design foreign language fonts. Among contemporary HALO '88 applications are CAD, Computer-Based Training, Presentation Graphics, Graphic Arts, Mapping, Machine Vision, Silicon Wafer Manufacturing, Sound System Design, Vehicle Scheduling and Routing, and Real Estate.

Join the HALO Family

HALO has an installed base of 60,000+ end-users, hundreds of site-licensed corporations, government agencies, universities, and national laboratories and most importantly, over 220 Independent Software Developers (ISVs) who market applications written with HALO.

HALO '88 provides the software designer with the richest environment of graphics functions; the programmer with reliable and

well-documented tools, and DP managers with continuity of user interface and database format.

Reach for the Future

If you need high performance graphics development software that provides a migration path to OS/2 and other future technology, follow the industry leaders — call (800) 992-HALO (4256).

HALO '88 is just \$325 and includes all device drivers, 20 fonts, your choice of one compiler binding, completely new documentation, an interactive tutorial and free 800# technical support.

Ask about the new HALO Programmers' Workbook which provides C program examples for HALO '88 applications developer

media cybernetics
8484 Georgia Ave.
Silver Spring, MD 20910
(301) 495-3305, (800) 992-HALO

HALO is a registered trademark of Media Cybernetics, IBM PS/2, VGA and OS/2 are registered trademarks of International Business Machines Corp.



Secret Codes

Any good data security system must rely on encryption

Asael Dror

Cryptography is the ancient art of making the comprehensible incomprehensible to all but a chosen few—of keeping secrets secret. Julius Caesar is credited with protecting the secrecy of messages by replacing every letter in the original text, called the *plaintext*, with a letter three characters later in the alphabet. The result is called a *ciphertext*, in which *A* is represented by *D*, *B* by *E*, and so on.

The war between cryptographers, who devise *cryptosystems*, and code breakers, who try to decipher encrypted messages, has drastically escalated since the invention of the computer. On one hand, computers help to break complicated cryptosystems within seconds. On the other hand, they make it feasible to use extremely complex encryption algorithms that were not practical before. Furthermore, the advent of distributed computer systems, the wide availability of microcomputers, advances in mass storage, and the widespread use of computer communications have all contributed to moving cryptography from military and diplomatic fields to those of more general interest and importance.



Two major cryptosystems are in use today: conventional systems and public-key systems. Two major encryption algorithms relate to these cryptosystems: DES and RSA, respectively.

Conventional Cryptosystems

One important method of encryption is *substitution*: replacing every occurrence of a letter (or word, or byte) with a differ-

ent letter (or word, or byte). The XOR operator is a convenient way to perform substitution with computers. When you XOR 2 bits together, the result is 1 if one and only one of the input bits is 1. The result is 0 if both input bits are 0, or if both input bits are 1.

The XOR function is convenient because it's fast and you can decrypt the encrypted information simply by XORing the ciphertext with the same data that you used to encrypt the plaintext. For example, you can encrypt the word *TEST* by XORing every byte with the ASCII representation of the letter *A* (0100 0001). In figure 1a, the letter *A* is the key used to encrypt the plaintext. To decrypt the message, you XOR it again with the same key, as in figure 1b.

The strength of a good cryptosystem doesn't depend on keeping its algorithm secret; the secrecy of the ciphertext relies solely on the secrecy of the key.

A *statistical cryptanalysis* attack can easily break a simple cryptosystem. Natural language has specific known patterns, such as the frequency with which each letter is used; common letter combinations, such as *th*, *er*, *ing*, and *ion*; and

continued

word-usage frequency. Those plaintext patterns will also appear—although their expression will differ—in the ciphertext; once you recognize them, you can use them to break the cipher. Alternately, you can break the cryptosystem with a *brute-force* attack. Since there are only 256 possible keys (binary 0000 0000 to 1111 1111), a computer can quickly try them all.

One way to overcome these problems is to use longer keys. For example, you could use a four-“letter” key such as A5GE (a good “random” key). In this case, you encrypt the first byte with *A*, the second byte with *5*, the third with *G*, and the fourth with *E*. After exhausting the key, you reuse it; so you encrypt the fifth byte using *A* again, and so forth. The key length is 4, making it harder, but not impossible, to use letter-pattern methods to break the code.

Unfortunately, if code breakers know (or can guess) part of the plaintext (e.g., if they know that every message begins with “Dear Sir”), then they can use *analytical cryptanalysis* to derive the key. In figure 1, XORing the plaintext with the ciphertext reveals the key.

Ideally, you should have a key that never repeats. Such a key, composed of random bits and never reused, is called a *one-time tape* (or *one-time pad*). You can prove mathematically that a cryptosystem based on a one-time tape is unbreakable. Unfortunately, such a cryptosystem requires a key as long as the message you want to encrypt; so then you have to figure out how to transmit the key safely. Still, one-time-tape systems are usable when a safe transportation means is

available now but won't be in the future, when you need to transmit the secret message.

It may seem that you could create a one-time-tape cryptosystem by extending a short key with a computer's random-number-generating function, using the short key as the seed. Although many commercially available data-encryption packages use such a scheme, it should be considered more of a toy than a cryptosystem. A computer's random-number generator actually generates pseudo-random numbers. A mathematical relationship exists between each generated number and the one that follows it. Consequently, such proprietary cryptosystems, often described as unbreakable, can usually be cracked within minutes (see reference 1).

DES

Since a layman cannot tell the difference between a secure cryptosystem and a complete mockery, the National Bureau of Standards (NBS) established the Data Encryption Standard (DES). It was originally developed by IBM and adopted as a standard by the NBS in 1977. In 1980, it was adopted by ANSI.

Prior to becoming a standard, the security of DES was validated by the National Security Agency (NSA), which found the algorithm free of any statistical or mathematical weaknesses (see reference 2). Since its adoption as a standard, DES has been used by most banks for money transfers and by most U.S. government agencies (except the military).

DES works on one 8-byte (64-bit) block at a time. The encryption process is

controlled by a user-supplied 56-bit key; that's 2^{56} (72,057,594,037,927,946) possible keys. Every bit in the output is a complex function of every bit in the input block and every bit in the key. Decryption under DES is the reverse of encryption and is performed by working the algorithm backward. The encryption process (see figure 2) consists of an initial permutation of the input block followed by 16 rounds of encipherment, and finally an inverse of the initial permutation.

After the initial permutation, the block being encrypted is divided into two parts, called L_0 and R_0 . In each of the 16 rounds of encipherment (see figure 3), the new *L* part is the previous round's *R* part. The new *R* is the previous round's *L* part XORed with the result of the *cipherfunction* f . Thus, the output of round i is

$$L_i = R_{i-1}$$

$$R_i = L_{i-1} \text{ XOR } f(R_{i-1}, K_i)$$

The cipherfunction f (see figure 4) derives its output based on the old *R* part (R_{i-1}) and the current round's key (K_i). You use the inputs to perform substitution via eight lookup tables called *S* boxes and then permute the combined output of the *S* boxes to give the function's output.

Each round uses a different 48-bit key, K_i . You derive the current round's keys by performing a set of permutations and left shifts on the user-supplied 56-bit key. DES defines the exact left shifts and permutations used to derive each round's key, as well as the definition of the *S* boxes and all the other required permutations (see reference 3).

The strength of DES has been ascertained by the NSA's thorough analysis and years of widespread use without any known break in the system. DES's biggest weakness is its limited key length. Its critics claim that you might be able to break DES with a brute-force attack (i.e., by trying every possible key).

However, trying all possible keys within a reasonable time frame would require a special machine that would use as many as 1 million processors working concurrently. Each processor would decrypt the ciphertext using a different set of keys and check (e.g., by using a dictionary) to see if it had guessed the correct key. Even though it would cost millions of dollars to construct such a machine (if at all feasible), the fact that DES is in such common use creates an incentive to develop it. However, this theoretical shortcoming is no reason not to use DES. If you are worried about it, you can easily

(a)				
Plaintext: (TEST)	0101 0100	0100 0101	0101 0011	0101 0100
Key: (the letter A)	0100 0001	0100 0001	0100 0001	0100 0001
Ciphertext: (plaintext XOR key)	0001 0101	0000 0100	0001 0010	0001 0101
(b)				
Ciphertext:	0001 0101	0000 0100	0001 0010	0001 0101
Key: (the letter A)	0100 0001	0100 0001	0100 0001	0100 0001
Plaintext: (ciphertext XOR key)	0101 0100	0100 0101	0101 0011	0101 0100

Figure 1: A simple example of (a) encryption and (b) decryption using the XOR operator.

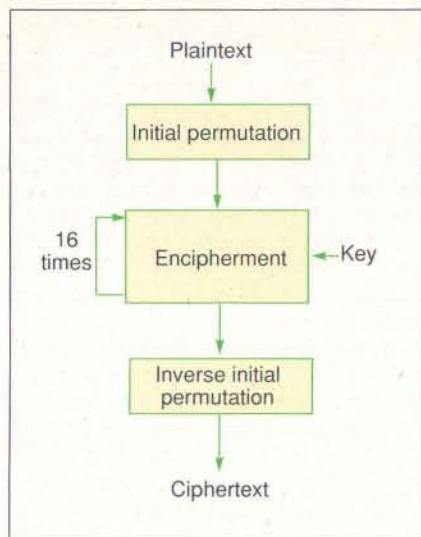

Figure 2: The DES encryption process. Every bit in the output is a complex function of every bit in the input block and every bit in the key.

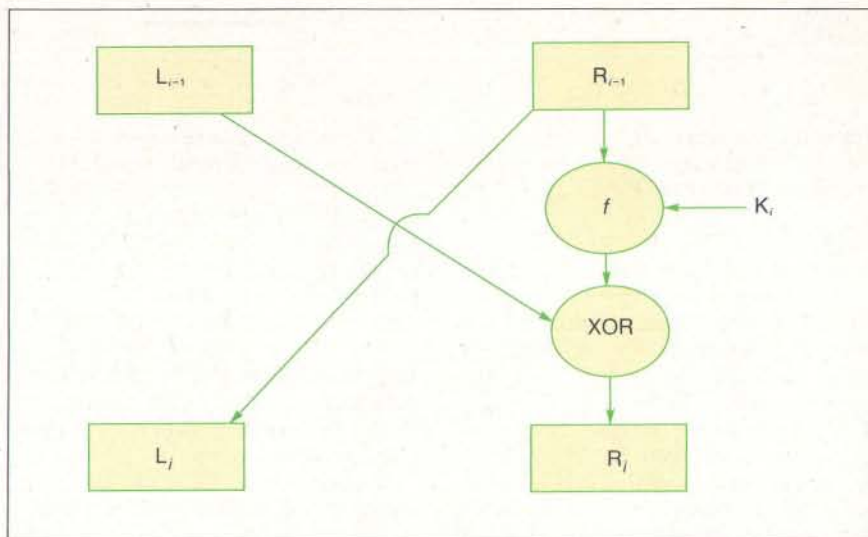

Figure 3: The details that are involved in each of the 16 rounds of encipherment shown in figure 2. Note that the new L part is the R part from the previous round, and the new R is the L part from the previous round XORed with the result of cipherfunction f .

overcome it by using an additional pre-DES encryption stage.

Public-Key Cryptosystems

When using a conventional cryptosystem such as DES, both the sender and the receiver must know the key used to encrypt (and decrypt) the data. Therefore, you need a safe means of transmitting the key from one to the other. If you change the keys frequently, transmitting them becomes a major problem. Furthermore, with a conventional cryptosystem, it's impossible to communicate with someone new until you have safely exchanged keys; this can take a long time. Public-key cryptosystems are designed to overcome these shortcomings.

Public-key cryptosystems are based on the use of a *trap-door one-way function*. You can easily compute such a function in one way only—used to encrypt the data. To compute the function in the other direction—used to decrypt the data—you must have certain secret information; hence, the name *trap-door*.

In a public-key cryptosystem, each person has two keys: one for encrypting, E_A , and one for decrypting, D_A . Decrypting with D_A a plaintext P that was encrypted using E_A restores the original plaintext—that is, $D_A(E_A(P))=P$. Both E_A and D_A should be easy to compute, but knowing E_A does not reveal D_A .

If you use a public-key cryptosystem, you can publish your encrypting key E (the public key) in a public directory, while you keep D (the private key) secret. If someone wants to send you a message, all that person has to do is look up your public key (E_A) and use it to encrypt the message as $E_A(P)$. Only you

continued

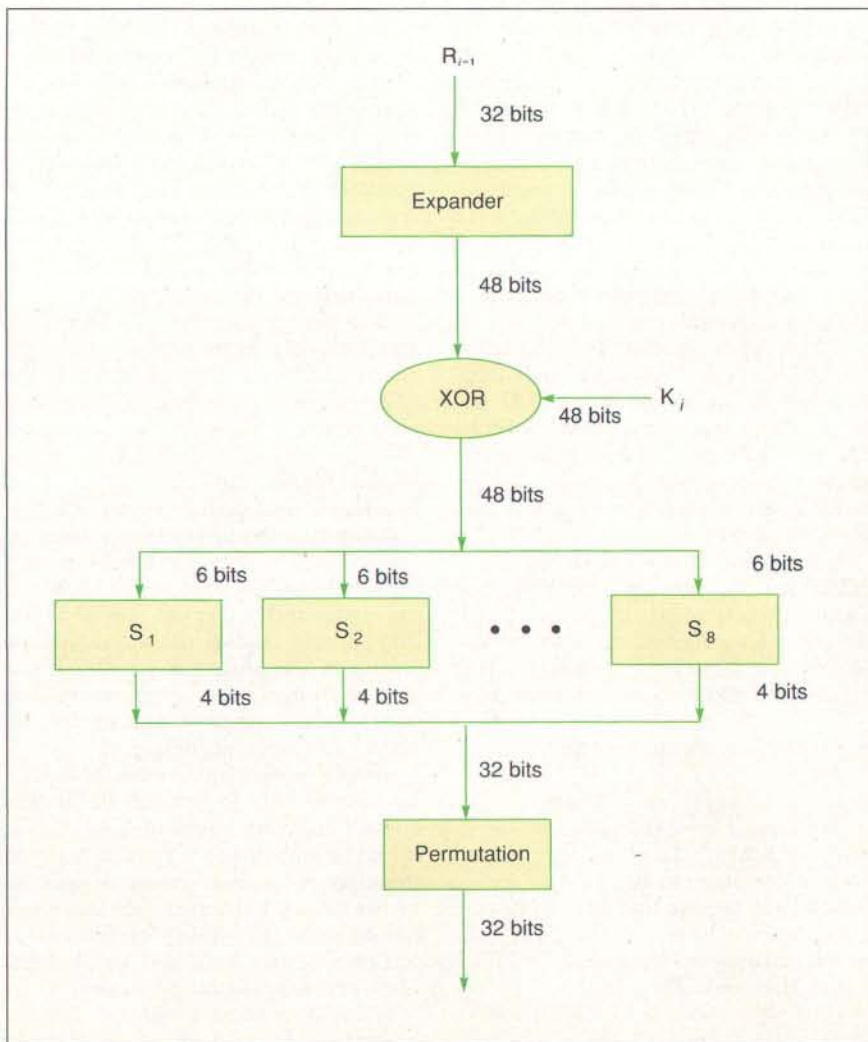

Figure 4: Cipherfunction f from figure 3. Its output comes from the old R part (R_{i-1}) and the current key (K_i). The inputs use eight S boxes to perform substitution and then permute their combined output to give the function's output.

know the private key D_A , so only you can decrypt the message back to its original plaintext, $D_A(E_A(P))=P$.

RSA

The most important public-key cryptosystem today is RSA (see reference 4), named after its inventors, Rivest, Shamir, and Adleman. To use RSA, you need to choose, at random, two large prime numbers, to be called p and q . Compute n as the product of the two primes: $n=p*q$. Then, randomly choose a large number d , so that d is relatively prime to $(p-1)*(q-1)$; in other words, the greatest common divisor of d and $(p-1)*(q-1)$ is 1. Finally, compute e so that $(e*d)$ modulo $((p-1)*(q-1)) = 1$. The notation " x modulo y " signifies the remainder of dividing x by y using integer division. For example, 20 modulo 5 = 0, since $20/5 = 4$ with 0 remainder; 13 modulo 3 = 1 since $13/3 = 4$ with 1 remainder.

The public key is the pair of numbers (e,n) , and the private key is (d,n) . Although n and e are public, it is difficult to arrive at d , since there is no efficient algorithm for factoring large numbers. Consequently, to be secure, both p and q must be very large (at least 100-digit numbers), so that n is extremely large (at least 200 digits) and cannot be factored within a reasonable time.

To encrypt with RSA, first you break the plaintext into blocks that can be represented as an integer between 0 and $n-1$. Then, you encrypt each block by raising it to the power e , modulo n . To decrypt the block, raise it to the power d , modulo n ; that is, $C=P^e$ modulo n , and $P=C^d$ modulo n .

Let's look at an example of how to use RSA. For the sake of simplicity, you should use very small primes for p and q . To create a secure system, however, you should use very large primes (to find large prime numbers, see reference 5).

- Assume you choose $p=3$ and $q=11$.
- Then, $n=p*q=3*11=33$ and $(p-1)*(q-1)=2*10=20$.
- You can use $d=7$, since 7 is relatively prime to 20.
- Next, you need to find an e , so that $e*7$ modulo 20 = 1.
- You can use $e=3$ because $3*7=21$, and 21 modulo 20 = 1.
- Thus, your public key is (3,33) and your private key is (7,33).

If you represent your message by using a 1 for A, 2 for B, 3 for C, and so on, the plaintext DEAD would be written as 4 5

1 4. The following table shows how to encrypt this using the public key (3,33).

P	P^e	P^e modulo n
4	64	31
5	125	26
1	1	1
4	64	31

Thus, the ciphertext is 31 26 1 31 (using large primes would let you create large blocks that would conceal the patterns detectable in this simplified example).

To decrypt this, you would use the following to restore the original plaintext.

C	C^d	C^d modulo n
31	27512614111	4
26	8031810176	5
1	1	1
31	27512614111	4

The RSA algorithm has been known since 1978, and in no known case has it been broken. Its strength is based on the complexity of factoring very large numbers. However, while no algorithm has yet been found to efficiently factor large numbers, such an algorithm may exist. If such an algorithm is found, RSA would be rendered useless. Furthermore, no one has proven that factoring n is essential to deriving the private key.

On a more practical note, RSA's operations on very large numbers make the system extremely slow. In addition, the RSA algorithm is patented, and you can't use it freely.

Digital Signatures

In addition to ensuring privacy, encryption can be used to verify authenticity. Say you send your broker a message telling him to sell all your stocks. How can the broker verify that you sent it? If you dispute ever sending the message, how can the broker prove that you did? If you used paper mail, your signature would be used to verify and prove authenticity, but how about electronic messages?

Simply encrypting the message using a key known only to you and the broker doesn't solve the problem. The broker would be satisfied that you had sent the message, but couldn't prove it since he knows the key and thus could have forged the message. Public-key cryptosystems can provide an elegant and simple solution by creating *digital signatures*.

A trap-door one-way function has the property of $D(E(P))=P$. If the function used by the public-key cryptosystem also has the property of $E(D(P))=P$, it is said to be a *trap-door one-way permutation*. The RSA public-key cryptosystem ful-

fills this requirement. Using such a public-key cryptosystem, you can encrypt the message using the private key D_A . Anyone who receives the message $D_A(P)$ can decrypt it using your public key E_A , since $E_A(D_A(P))=P$. Since D_A is known only to you, the recipient knows, and can prove, that you are the author.

If you want to send a private message that can be authenticated to someone else, then you encrypt $D_A(P)$ with that person's public key, giving $E_B(D_A(P))$. Using the private key, D_B , that person would derive $D_B(E_B(D_A(P)))=D_A(P)$, which would be saved as proof of authenticity, and then decrypt $D_A(P)$ by using $E_A(D_A(P))=P$. Thus, both privacy and authenticity have been achieved.

Secure Computer Systems

Any good computer data security system must rely on encryption. Whereas both DES and RSA provide a good basis for a computer security system, using proprietary algorithms may be worse than using no encryption at all, because they lead to a false sense of security.

But encryption alone is not sufficient. Proper key selection, key management, physical security, people security, and procedures to ensure that plaintext does not "leak" out of the system via loopholes (see reference 6) are all essential for a secure computer data system. ■

REFERENCES

1. Kochanski, M. "A Survey of Data Insecurity Packages." *Cryptologia*, January 1987, pp. 1-15.
2. Meyer, C., and S. Matyas. *Cryptography: A New Dimension in Computer Data Security*. New York: John Wiley & Sons, 1982.
3. National Bureau of Standards. *Data Encryption Standard*. Federal Information Processing Standard Publication 46, 1977.
4. Rivest, R., A. Shamir, and L. Adleman. "A Method for Obtaining Digital Signatures and Public-Key Cryptosystems." *Communications of the ACM*, February 1978, pp. 120-126.
5. Knuth, D. *The Art of Computer Programming, Vol. 2: Seminumerical Algorithms*. Reading, MA: Addison-Wesley, 1969.
6. Dror, A. "Data Protection and Encryption." *The Waite Group's MS-DOS Papers*. Howard W. Sams, 1988, pp. 217-239.

Asael Dror is the founder and president of Wisdom Software, located in San Francisco, California. He is the author of File Encrypt, a DES encryption program for MS-DOS and OS/2. He can be reached on BIX as "asacl."

Unique New Service Keeps Telecommunications Costs Under Control

No matter how complex your voice communications services are, no matter how many locations you manage, TRACKER™ from CCMI/McGraw-Hill can now give you the information you need to contain costs and save money.

Drawing on years of experience gathering and analyzing rate and tariff data, CCMI/McGraw-Hill created TRACKER to provide you with an instant look at your current services by location . . . and then compare your alternatives. Through this unique database, you can quickly identify where to reduce costs at a price that more than pays for itself.

Designed for users large and small, TRACKER solves many of today's information problems such as the confusing array of services and constantly changing rates. Because CCMI/McGraw-Hill is not a carrier, you're guaranteed objective, unbiased information . . . information you need to identify where the largest savings are.

TRACKER has proven itself to be the answer to lower costs in the increasingly complex

telecommunications environment. To learn more, call today.

1 800 526-5307 Ext. 249



CCMI/McGraw-Hill
500 North Franklin Turnpike
Ramsey, New Jersey 07446

Yes! I'm interested in discovering a proven new way to keep my telecommunications costs under control.

Send me more information about TRACKER.

I can't wait! Call me right away.

Name _____

Title _____

Company _____

Address _____

City _____ State _____ Zip _____

Telephone _____

Clip coupon and mail to: CCMI/McGraw-Hill,
500 North Franklin Turnpike, Ramsey, NJ 07446

WE PROUDLY ANNOUNCE
THE BIRTH OF



THE DUAL DISC



 Some babies simply change the world. Take ours, for example. The Dual-Disc Mirror (welcome, welcome) consists of two identical hard discs. All data is written simultaneously on both discs to rule out data loss. We call it 'mirroring'. And we call it a revolution.

A back-up can be made from one of the discs onto back-up media without affecting the system users. And there is more. Like alternate read. When information is needed from the disc, DDM issues read instructions alternately to each of the two discs. This results in an increase in speed because the system does not have to wait for one disc to finish each operation. And, as an option, both discs can be reorganised automatically at any time you preselect. Programs and data remain accessible in a flash.

The Dual-Disc Mirror works on Unix.[®] Our software is in use at several international organizations, companies that depend on their data files around the clock. From the moment they were installed, they simply never failed. So our baby will go a long way.

TWIN
COM Professional Program Products

Call or write in USA: Twincom, 5220 Hollywood Ave, Shreveport, LA 71109. Tel: 1-800-234-8088. Fax: 318-635-5319.

Call or write in Europe: Twincom, Slotje Limburg, Slotlaan 15, 4902 AD Oosterhout, The Netherlands. Tel: 31-1620-23936. Fax: 31-1620-23974.

Unix[®] is a trademark of AT&T.

THE SIVA 386 20MHZ SYSTEM

delivering superior Quality, Performance & Value!

VNS includes many important options as standard: **\$1995**
40MB Hard Disk, 1MB Memory and more! Priced at

Meet us at



June 20-22, '89
Booth 2028



All Systems include DOS 3.3
for \$35 additional

Complete System Features:

- 32-bit Intel 80386-20 CPU
- 1MB of 32-bit RAM on board expandable to 16MB
- 16/20 MHZ keyboard selectable
- ST-251-1 Seagate 40MB formatted 28ms high speed, with ultra high speed controller 1:1 interleave
- 1.2MB high capacity floppy drive
- Super deluxe heavy duty tower case with 7 half-height drive bays
- High-resolution 12" non-glare amber display; Tilt and swivel base, Hercules-compatible Adapter
- 101 key enhanced keyboard; pleasant "Tactile-Click" feel
- 80287/387 math co-processors optional
- Fully compatible with virtually all XT/AT and 386 software

System Upgrades:

- VGA color upgrade — add only \$495
- EGA upgrade — add only \$395
- 80 MB — \$395
- Call for all other options and upgrades

Please call us for information on the great XENIX Software/SIVA 386 System offer.

NEW SIVA 286 20MHZ SYSTEM

\$1595



Complete System Features:

- CPU 80C286 at 16/20 with Zero Wait RAM
- Expandable to 4MB on board (STD 1MB)
- Award BIOS with built-in setup
- 40MB hard drive; 1.2MB floppy drive with high speed floppy/hard disk controller 1:1 interleave
- High resolution 12" monochrome monitor with tilt and swivel base
- Real time clock calendar with battery back-up
- On board 80287 co-processor socket
- 4-16 bit and 1-8 bit expansion slots available
- 2-Serial, 1-Parallel and 1-Game port
- 101 keyboard fully AT-compatible
- DOS, OS/2, XENIX-compatible

Call us for delivery details on the popular 12MHZ SIVA 286 Model 210 System at \$1295

*We Welcome Inquiries
from OEMs and VARs*

VNS America Corp.

**Order Now Toll-Free
1-800-252-4212**

910 Boston Post Road • Marlboro, MA 01752 U.S.A. • In MA 508-481-3726 • FAX: 508-481-2218

All prices subject to change without notice.

Working Hours: 9 a.m. - 6 p.m. E.S.T. Monday - Friday

Know Thy Viral Enemy

The viruses you're most likely to meet. Check them out, but don't be fooled into thinking you can beat them on your own.

Ross M. Greenberg

In the late fall of 1987, a message went out from Lehigh University in Pennsylvania indicating that one of the folks in the computer lab was busily fighting a virus program. The virus in question, dubbed the "Lehigh virus," spread itself from computer to computer using an infected disk as its mode of transmission. For a "clean" computer to be infected with this virus, it had to be booted up with an infected disk in drive A. Hundreds of computers were rapidly infected.

After a number of replications, the virus "turned Trojan" and wiped out the data on the infected machines' hard disks. A *Trojan program*, named after the infamous Trojan horse of Greek mythology, is a program that produces a one-time disaster, damaging or destroying data or disks as soon as it is executed.

Currently there is a big drive to develop ways to diagnose and stop viruses before they infiltrate networks and cause irreparable damage to expensive devices, peripherals, and irretrievable data. Many viruses have been identified, but there are several PC viruses considered to be the most prevalent—Israeli, Le-

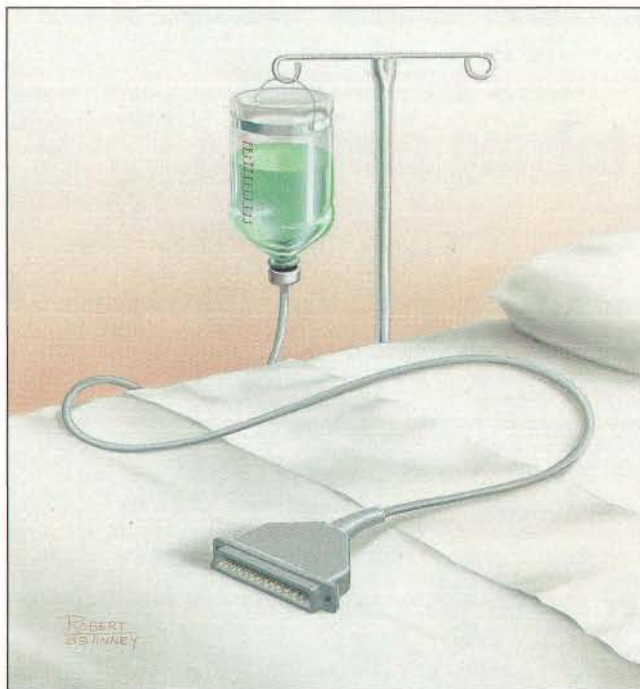

high, Pakistani Brain, and Alameda. There are also two lesser-known viruses that I have run into in my work. They are discussed in the text box "Two Other Viruses I Have Known" on page 277. And for Mac environments, see the text box "Two Mac Viruses" on page 278.

The main avenue that viruses take to invade PCs is through the use of an infected floppy disk. Virus strains are be-

coming more virulent and sophisticated; some can hide themselves so well even the best utilities are unable to find them. There are even viruses that can secrete themselves in nonvolatile memory, making system reinfection an increasing problem. Shrink-wrapped software not only is not immune from carrying viruses, it has actually been the cause of many systems becoming infected. CD-ROMs also have been degraded with these nasty diseases at the time they were pressed.

In the DOS environment, viruses use JMPs or other system files to ply their trade. The most common way a system can become infected is through its I/O calls. Actually, viruses use any "chink in the system's armor" to infiltrate the environment. And there's no such thing as a "bulletproof" system.

Although there is widespread controversy over viruses, some basic information may serve to set the scene. Consisting of a number of parts, a *virus* is a code that infects other programs, is self-replicating, and requires a host or executable disk segment. Once it is physically in a system, it can damage or destroy data,

continued

AMD Austin

There's no better place for PC Architects to be.

We're looking for the best PC architects to help develop hardware and software products based on our 286-type World-Class Solutions, a growing product area driven by strong market demand and headed for an even bigger future. To qualify, you must have experience in digital systems design, knowledge of DOS or OS/2, ability to design complex, system-level products, and an in-depth knowledge of PCs.

The place is Austin, Texas, one of the country's fastest-growing high tech centers, a city known for its affordable housing, beautiful nearby Hill Country, and higher quality of life. Yes, Austin is one great place to live. No, AMD isn't just an IC house anymore... we're powering our way into the future with World-Class Systems Solutions that lead their markets in many categories.

Come and join our team doing system design in a semiconductor environment. For immediate consideration, call Richard Holtry at (800) 531-5202, x5470. Or write: Advanced Micro Devices, Department MS-556-B, Attn: Richard Holtry, 5204 East Ben White Blvd., Austin, TX 78741. We are an equal opportunity employer.



People are talking about us.

When professional FORTRAN programmers develop or port large programs they use Lahey's F77L-EM/32 and F77L-EM/16, *PC Magazine's 1988 Technical Excellence Award Winners*. F77L-EM/32 is a fast 32-bit protected-mode compiler that accesses up to 4 gigabytes of memory on 80386s. F77L-EM/16 gives 80286 users the power to create 15 megabyte programs. These protected-mode FORTRANs include the features that have made them, and our F77L and Lahey Personal FORTRAN, market leaders: full ANSI 77 Standard, VAX and IBM VS extensions, fast compilation, comprehensive diagnostics, and a powerful debugger.



When people talk about FORTRAN
the name mentioned most often is

Lahey
Computer Systems, Inc.

Contact us to discuss our products and your needs. (800) 548-4778
Lahey Computer Systems, Inc. P.O. Box 6091, Incline Village, NV 89450
Tel: (702) 831-2500 FAX: (702) 831-8123 Tlx: 9102401256

media, the system itself, and any attached peripherals.

Essentially, a virus has four phases: the dormancy phase (optional), the propagation phase, the triggering phase, and the damaging phase. A propagation phase is all that is necessary for the program to be a virus; a virus does not have to cause damage. The creator of a virus might use a dormancy phase to instill a sense of trust in the user since the virus does not propagate or do damage during this phase. The triggering phase is launched by some occurrence, such as a certain date or a particular number of replications. Finally, the damaging phase does whatever harm the author intended the virus to do.

Some viruses even have a *pretrigger*. This is a piece of code that lets the virus benignly sit in a program until something transpires, such as a particular date or timeframe, the presence of another program or file, or the capacity of the disk exceeding some certain limit. Generally speaking, very few viruses have a pretrigger.

If the virus doesn't have a pretrigger, or if it does and its pretrigger goes off, then the virus or virus replication mode activates. At this stage, the virus replicates a virtual copy of itself into other programs or into certain system areas on your disk. When loaded and executed, each infected program or system area is a clone of the virus itself and will produce

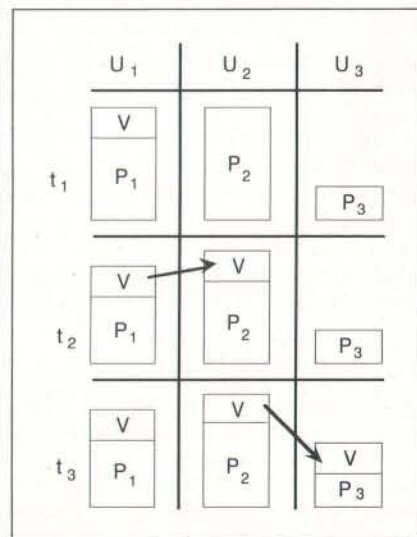

Figure 1: A picture through time of a virus infecting a system. A virus, V, infects user U₁'s program P₁ at time t₁. At t₂, U₁ shares information with U₂ and infects P₂. When U₂ shares data with U₃ at t₃, P₃ becomes contaminated. (Figure courtesy of Fred Cohen)

Two Other Viruses I Have Known

Not all viruses trash your disk; some trash your data, and these are potentially more dangerous. You can always restore your programs from their distribution disks, but your data is yours alone and you might not even notice a change until it's too late.

The dBASE Virus

The dBASE virus isn't a problem with dBASE itself; it's a virus I ran across at the office of a client who was running dBASE. Thus, I named it the dBASE virus. It's a TSR virus that works in a manner similar to the Israeli virus. The virus intercepts calls to DOS interrupt 0x21 and looks for open calls to files with a .DBF extension. When the virus finds such a call, it stores the returned file handle in a data location within its code space and stores the current size of the .DBF file as well.

Subsequent write operations that would expand the size of the .DBF are made with the first 2 bytes transposed. Future reads also have the first 2 bytes transposed. Therefore, for as long as the virus is installed in your system, everything looks fine. However, after 90

days, it will destroy your file allocation table. And when the virus is exterminated, you will find that the data in your .DBF file is worthless.

The dBASE virus creates a hidden file, called BUG.DAT, the contents of which indicate which records (by byte offset) have a series of bytes transposed and where those bytes are. If you're a dBASE user and the next time you run a CHKDSK you see your hidden file count go up, you should check your disk for this file in the same directory where the .DBF files reside. If it's there, you're infected.

If you create the BUG.DAT file and make it read-only, the dBASE virus won't be able to open the file for read/write access and your data will be safe. This file must exist, however, in each directory you use for storing your .DBF files.

The Screen Virus

More than one virus creates TSR problems and byte transpositions. The one I call the Screen virus is a simple one. After it goes TSR, it waits for the timer tick and wakes up every few minutes.

When it wakes up, it examines the screen memory and looks for any four contiguous digits starting at a random place on the screen. When it finds them, it transposes two of them. This process is not as harmless as it sounds.

The Screen virus is a dumb virus—it doesn't check to see if a piece of code is already infected. When first executed (before it goes TSR), it will infect every .COM program in your current directory (including copies of itself if the disk image resides in the current directory). Then, of course, if you use a floppy disk with this virus on it in another system, you will infect the new environment.

This virus does have an identifying characteristic that you can use to determine if you're infected: a file that includes the word `InFeCt`. If you find `InFeCt`, read the 4 bytes immediately preceding it and overwrite the first 4 bytes of the program with their value. Then truncate the program at their stored address. By so doing, you've rid yourself of a nasty virus and restored the program to its pristine state.

Finally, make sure you use a clean copy of your disk editor.

more clones (see figure 1).

Don't confuse viruses with "worms." A worm is a piece of software that takes over the resources of a computer (worms its way through the core of the data, for instance) and uses them for its own purposes. Strictly speaking, a worm is not a virus because a virus must actually infect other programs with a copy of itself.

In November 1988, when the Internet (a tightly coupled network of machines throughout the U.S., each communicating with all the others on the network) was infected, it wasn't infected with a virus. It was infected with a worm. The Internet infection used the network's own facilities to spread the bogus code. When it reached the target system, it used the resources of that system to further propagate the infecting program. This process is typically considered a worm, since no preexisting program was infected.

Generally speaking, viruses wreak their havoc in the Macintosh, Amiga, and other environments as well as in the DOS world. Most of the viruses that have been seen to date, however, carry out their damage in an operating-system-specific manner.

The Anatomy of a Virus

It is important to realize that virus programs, in and of themselves, can be innocuous and don't necessarily have to be created with malicious intent. They can be the work of someone who wants to play a practical joke or of people who are experimenting with the technology.

On a DOS system, simple viruses infect the most basic programs of all, the .COM files. These files are almost an exact image of the memory image of the program run after they are loaded. At load time, only upon examination of the segment registers can such a program tell where it has been loaded in memory. The majority of these .COM programs start with a JMP instruction—there is a theory that you should always have the data at the very beginning of your program. This is not strictly true, but programmers usually follow this procedure when they write their programs.

If the JMP instruction at the beginning of the program is modified so that it points to other code, the CPU will automatically run that code. After the virus program has done its dirty deed, it must run the original program as if it were not infected. Since the virus need not be con-

cerned with the meaning of the original data bytes it displaced to infect the errant program, it can treat these bytes just like data, move them back into their original location, and then allow them to execute without any regard to what those bytes are. Therefore, even programs that do not start with the simple JMP instruction can be infected.

A virus can be written in one of two ways: as position-independent code or as position-dependent code. A position-independent virus is usually added to the end of a program. It has no need to manipulate more than the first 3 bytes of the original program—just enough to branch the program's run to itself. Position-independent code is a little harder to write, since at run time, all data accesses must be localized and resolved.

Position-dependent viruses must be set to execute at the start of the program and typically will copy the original instruction(s) at the beginning of the uninfected program to the physical end of the program's data image on disk. Such viruses must also have a block-move routine that must either be position independent (so that it can run from any location) or use a

continued

Two Mac Viruses

Janet J. Barron

In the Macintosh environment, viruses go after operations resources—they use the Mac's architecture as a way to get around in the system. You can eliminate Macintosh viruses by replacing the System Folder and any affected application with clean copies from the original master disks. There are two major viruses that particularly plague Macs—nVIR and Scores.

The first, nVIR, comes in a variety of forms—at least a dozen have been detected, each with its own individual activation characteristics. nVIR's technique for spreading is especially virulent. It invades the System File; once this crucial resource is infected, every application that is subsequently launched is contaminated.

The second, the Scores virus, may account for about a third of all viral attacks, although so far there hasn't been a significant amount of devastating damage. Many government agencies' systems are thought to have been plagued with an infection of Scores. Personnel at NASA's Washington, D.C., headquarters and at the University of California in San Diego have detected the Scores virus in their machines. According to a NASA virus investigator, the agency believes that its

Macs contracted Scores by downloading an infected program from a BBS.

It takes only a minuscule amount of time for Scores to spread. And if a Mac's System file is plagued with the disease, any application that runs from that System will also have it. This particular virus infects any Mac application by increasing its size by 7000 bytes.

You can quickly tell if your Mac is infected by opening your System Folder. Check out the small Scrapbook and Note Pad file icons. If they're not the usual crisp representations of Mac icons and they look like generic documents, then you may have a case of the Scores virus. This technique won't work with nVIR because its mode of replication is different.

You can use your ResEdit, the resource editor, to identify viral resources and invisible files, but don't use it to try and kill off the virus. If you attempt to banish the individual resource, the Scores virus changes its resource identifiers, and they come back to haunt you again the next time you boot up. Even after removing the offending virus, some of your applications may not function properly because portions of the virus may still be lying low in your System Folder files.

The Scores virus spreads every time an infected application is launched. The virus lies in wait for two days. Then, when you boot your machine, the INITs installed by Scores load into RAM and begin executing their routines.

At 3½-minute intervals, the virus seeks new hosts. Subsequently, it creates Note Pad and Scrapbook files in the System Folder (hence the change in the icons) as well as invisible Scores and Desktop files. Then Scores begins to look for specific programs to damage or destroy. The whole process takes about a week, during which time you may experience system slowdowns, problems with peripherals and their performance, and even system crashes.

The usual preventatives prevail with both the nVIR and Scores viruses. Be extremely wary of using anyone else's software or downloading programs from unknown or not absolutely trustworthy sources. And always be sure to keep clean backups of your system and application software in case your system becomes infected through the use of a diseased disk.

Janet J. Barron is a BYTE technical editor. She can be reached on BIX as "neural."

known and quantified area of memory outside the program's memory image (e.g., unused areas in the low-memory interrupt vector or video table). These criteria are necessary so that the original code, misplaced by the virus, can be restored to its proper position and can run correctly.

The Israeli Virus

An interesting virus that doesn't really fall into either of these two categories (position dependent or independent) is the TSR virus, typified by the so-called Israeli (or Jerusalem) virus. It infects .COM and .EXE programs and can affect floppy and hard disks. It is spread via infected programs on floppy disks or by the use of floppy disks in infected computers.

When run, the TSR virus moves its position-dependent code into the beginning of its allocated memory, hooks into interrupt 21 hexadecimal (which is one of the main DOS interrupts), and then loads

and executes the disk image of itself. The disk image notices that the interrupt 21h hook is already in place and executes normally. When it finishes execution and exits, the loaded image resizes the memory allocation to include only the virus code itself, then executes a TSR command, returning you to the C> prompt but leaving behind a live virus to execute upon other load and execute instructions that come through future calls to interrupt 21h.

This virus also makes an attempt to cover its trail; before it tries to infect a program, it preserves the program disk image's attributes and date/time access. It then modifies the attributes to allow read/write access (marking a file as read-only doesn't help against this virus), infects the program's disk image, and then restores the original attribute and date/time stamp. You'll discover this virus when the size of the disk image increases by just over 1800 bytes.

Part of the code in this virus will

check the date. If it happens to be Friday the 13th (the trigger), it will turn Trojan and either trash your disk or delete programs as you execute them, depending on the version. Yes, that's right. There are actually different versions of some viruses.

The Lehigh Virus

The Lehigh virus, via which you can lose all your system and hard disk data, is really an infected COMMAND.COM. Whatever you type at the C> prompt is first processed by COMMAND.COM. When you boot your machine from an infected copy, the original vector for interrupt 21h is stuffed safely away at interrupt 44h (normally not used by any program), and then the DOS interrupt is revector to point to a portion of memory it has reserved for itself via a TSR call. (Version 2, discovered on February 2, used interrupt 63h.)

With this virus, when any disk access is made, the copy of COMMAND.COM

that exists on that disk is checked to see if it's already infected. If it is, then normal processing continues. Otherwise, the virus infects the clean COMMAND.COM and increments a counter. The version 1 strain of the Lehigh virus stores this counter on a computer's hard disk in the infected copy of COMMAND.COM. With floppy disks and with the version 2 strain, the counter is kept in memory.

Date and time stamps are not preserved, so by looking at the date on a disk's copy of COMMAND.COM, you can tell if it's been tampered with—a recent access date indicates that it has been. With the Lehigh virus, attributes on the disk image of COMMAND.COM are not modified, so a clean copy can remain that way if you mark it as read-only. Another alternative is to change the name of your clean copy of COMMAND.COM and then modify your CONFIG.SYS and AUTOEXEC.BAT files to point their SHELL and COMSPEC variables to the newly hidden copy.

After version 1 of the Lehigh virus has copied itself four times, it trashes your hard disk. This virus is transferred by sharing infected floppy disks as well as by using a clean disk in an infected system. Version 2 copied itself 10 times.

The Pakistani Brain Virus

The Brain virus infects the boot sector of a floppy disk. When you boot off the disk, the virus rereads itself into memory (in essence, becoming a TSR virus), moves the current boot record to an unused portion of the disk, then marks that portion as bad sectors.

A bad sector will no longer be accessed by DOS. The original boot record is now called, and when you boot, except for a great deal more disk operation than you're used to, you'd never notice the Brain virus's presence. Doing a directory on an infected disk will show the volume label as © Brain—and a CHKDSK will show a few bad sectors. Interestingly enough, when you use an infected system and do a directory on an uninfected disk, the clean disk will become infected.

The Brain virus takes over the floppy disk controller interface (interrupt 13h) and looks for certain operations on the disk. If it sees a read operation, it pushes the original read operation aside and attempts to read the boot track. If it sees anything other than a word equal to 1234 at byte offset location 4, it assumes that the disk is uninfected and then infects it.

This virus has no trigger but immediately starts to mark areas on your disk as bad even though they are good. Eventu-

The Brain virus marks areas on your disk as bad even though they're good.

ally, your disk will contain nothing but bad sectors—bringing everything to a halt.

This is a strange virus. As mentioned, it announces its presence with the volume label, and the virus itself contains text that reads: "Welcome to the Dungeon." Then it gives the names of two brothers in Pakistan who are supposed to have authored this virus, an address, telephone number, and a few other admonishments and warnings.

If you modify the boot record on your system to include the value as specified, you've effectively inoculated your system from the Brain virus.

The Alameda Virus

Working in a manner similar to the Brain, but not exactly like it, this virus also does its thing by infecting a system's boot sector. The Alameda, discovered at Alameda College in California, is a very small virus inhabiting only one sector.

It's not one that deliberately goes out and destroys files at random. The Alameda virus does damage data but, besides the boot sector, only in one very specific location on the floppy disk—the last track.

When a machine reads in the boot sector, it reads in the virus, which stores the real boot sector elsewhere. Once it's read in, the virus takes over and reads in the real boot sector, which controls what the machine does from then on. If you insert a nonwrite-protected disk in the A drive, when you do a warm boot, the virus replicates by moving the real boot sector down to the last track of the disk. The virus takes over the last track without regard to what is in it. If a file is there, it becomes corrupted. All floppy disks inserted during reboot can catch the Alameda virus.

continued



A Brand New Resolution The Handy Scanner HS-3000

Free HALO DPE™

The handiest little scanner in the world just got even better. The Handy Scanner 3000 from DPE offers you clarity and versatility in a little package. Like our other Handy Scanners, the Handy Scanner 3000 for the IBM PC, PS/2, and compatibles can handle almost all the jobs the desktop models can, but it's smaller and easier to use.

We give you the features you need the most in a Handy Scanner. The new 4-1/8" scanning width makes short work of the biggest pictures. You can switch the scanner between 400/300/200/100 DPI. For those really important pictures, the Handy Scanner 3000 lets you have it all with 400 DPI resolution. The real-time screen display lets you instantly see your scan, so you can quickly make scanner adjustments as necessary. With adjustable half-tones and contrast, you get a clean, clear picture. Two col-

ors, not one, are used to scan your originals, so colors such as red or reddish skin tones can be scanned without losing detail.

The Handy Scanner 3000 comes complete with full-featured, powerful software for scanning, editing, and merging text with your graphics. Saved scan files are compatible with almost all graphics software, including PageMaker, Ventura, WordPerfect 5.0 and many others. The package includes the scanner, interface card, the HALO DPE desktop publishing software package (worth \$195), a utility diskette and an instruction manual.

The Handy Scanner 3000 is a little scanner that does a lot, and now it does it even better.

\$299.95

ADDED SPECIAL NOW OCR SOFTWARE AVAILABLE

Converts scanned images from scanner into ASCII text for use with word processors, data bases, etc.

Reg. \$199.95
if purchased with HS-3000 ONLY

\$79.95

LOGITECH SCANMAN

- 200 dpi
- 4" scanning width
- IBM, PC, XT, AT, PS/2 (25 & 30)



Complete with Logitech™ "Scanware"™ Software

\$189.95

QUALITY CUSTOMER SERVICE
508-278-6555

TECHNICAL ASSISTANCE
508-278-6556



TOLL FREE ORDER LINE
1-800-635-0300

TRUE DATA PRODUCTS

115 MAIN ST., P.O. BOX 347
UXBRIDGE, MA 01569
508-278-6555
HOURS: MON-FRI. 9-6, SAT. 10-4 (EST)

CORPORATE P.O.'S WELCOMED

ALL PACKAGES SHIPPED UPS EXCEPT CANADA AND A.P.O.'s C.O.D.'S ADD \$2.30 MASTER CHARGE/VISA ADD 3% 1 YEAR WARRANTY UNLESS OTHERWISE NOTED PRICES TERMS CONDITIONS SUBJECT TO CHANGE WITHOUT NOTICE

The Alameda virus hooks into one of the keyboard interrupts. That's how it knows you're doing a Ctrl-Alt-Del. It stores itself in high memory, decreases the available memory by claiming the last 1024 bytes for itself, and tells the machine that the 1024 bytes don't exist. No other application can load on top of it—it will generate an "out of memory" error. In addition, the network shell won't always reboot when you try to load and run it—it will simply hang up during a warm boot.

The Alameda virus infects only true IBM machines. It does not, however, infect any 80286 machines, including IBM's, because it uses machine instructions the 80286 generally doesn't permit. On some IBM machines, there are programs you can't run because of the memory problem and other programs that won't operate because the virus prevents the proper CONFIG.SYS files from running.

Alameda's staff members suspect the virus came from another school in the Peralta community college district of which Alameda is a member. They believe the source is probably a programming student who wanted to do something unique and interesting. They have just about disinfected their environment by tracing at what stage the virus infects the disk and chasing down where it lives. They wrote a program that looks on the boot sector to see where the virus is and kicks it off. In addition, Alameda users have started booting from the network so the problem can't replicate in that way.

How to Ward Off Infection

A variety of good antiviral programs are available, ranging from freeware to shareware to commercial programs costing many hundreds of dollars. These pro-

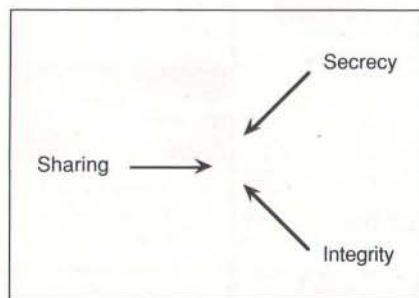

Figure 2: An impossible dilemma. You need and want data secrecy, sharing, and integrity. However, while you can achieve success in any two of the three, because of viruses, you can't have all three at once. (Figure courtesy of Fred Cohen)

You can
diminish your chances
of being hit with
a virus if you refrain
from putting any
new software
on your system.

grams come in many flavors, and there are many kinds for different machines.

- **Integrity checkers.** This type of program allows you to generate a unique signature or checksum for each program on your system. At boot-up time, these values are checked against the stored (and protected) copies. If there's a difference, you may have an infected program on your disk.

Obviously, programs such as SideKick that store their configuration options within the .COM file itself will have this value changed. Just be aware of such a potential triggering of the checker and you'll be in good shape. Realize that programs such as these will not stop an infection, but they will advise you of infected or modified programs.

- **Monitoring programs.** These programs are typically TSR programs for PCs and INITs for Macs. They sit on the interrupts and examine each one that comes by for suspicious activity. If they notice something the antiviral program's author thought was suspicious, they'll interrupt the operation, trigger an alert of some sort, and ask the operator what to do. Different programs have different options—you'll have to choose the one that serves your needs best.

A subclass of these two classes is a program that monitors for a load-and-execute instruction and does a checksum or signature check on the disk image of the program about to be loaded. If it has somehow changed from the stored value, the antiviral program triggers an alert.

- **Virus removers.** These programs examine the hard disk for signs of viruses that the antiviral program's author knows about. If they find a program with the footprint of such a virus, at the very least, they'll alert you to its presence. The better ones will also remove it.

Be aware that these programs can only catch and cure viruses that were known to the author. Before you buy one of them, ask the manufacturer of the product how many updates have been released in the last year. If there hasn't been an update for quite a while, you might want to shop around to find a company more active in its antiviral efforts.

- **Backups.** This is one defense against a virus, but it is not fail-safe. Some of your data might become corrupted by a virus, and the backup sets of that data might also be infected (see figure 2). You should run a virus checker after you've had to restore from a backup.

How Serious Are They?

Viruses are a serious problem, and they have the potential of becoming even more troublesome. Yet, if you take the proper precautions, you'll probably never be infected.

You diminish your chances of being hit with a virus if you don't put any new software on your system (including shrink-wrapped software and software downloaded from less-than-particular BBSes) and if you never use a network or boot a program from someone else's floppy disk. But in today's environment, these restrictions are less than realistic.

If you do install new software on your system, make sure you make a backup before you start working with it. A virus writer might have just as much access to a shrink-wrap system as the software manufacturers do. Many computer stores allow shrink-wrapped software to be returned to them, and there's no guarantee that when you buy it, you're not getting something extra you didn't plan on.

As more and more people network their machines, the threat of viruses becomes more and more serious. As it is, they have already caused millions of dollars' worth of damage and data loss and thousands of hours of downtime.

To protect your microcomputers, use common sense and as many preventive measures as you can. Don't be fooled into thinking you can beat the threat. ■

ACKNOWLEDGMENT

Thanks to Lehigh University's Ken VanWyk for his contributions to this material. He is the founder and moderator of an electronic virus discussion group called VIRUS-L.

Ross M. Greenberg, owner and chief executive officer of Software Concepts Design in New York, is a computer consultant and software designer. He can be reached on BIX as "greenber."

October 27, 1988

Mr. Charles Bostwick
Bostwick Parker Company
13644 148th Avenue
Detroit, Michigan 49684

Dear Mr. Bostwick:

The results of the computer simulation are in, and you'll find them quite fascinating. Here is an interesting surprise: the greatest sales potential exists with product number three. What's more, the largest sales will result from Europe and the Far East, not the United States.

Bostwick Parker Co.
New Product Sales Projections

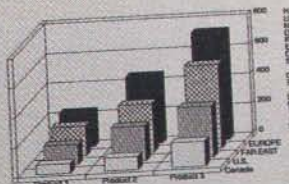

These sales projections take into account the requested in the model. Specifically, the growth rate was reduced to reflect the

October 27, 1988

Mr. Charles Bostwick
Bostwick Parker Company
13644 148th Avenue
Detroit, Michigan 49684

Dear Mr. Bostwick:

The results of the computer simulation are in, and I think you'll find them quite fascinating. Here is an interesting surprise: the greatest sales potential exists with product number three. What's more, the largest sales will result from Europe and the Far East, not the United States.

Bostwick Parker Co.
New Product Sales Projections

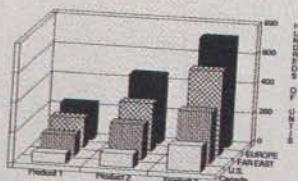

These sales projections take into account the requested in the model. Specifically, the growth rate was reduced to reflect the

CAN YOU SPOT THE \$700 DIFFERENCE?

One of the nearly identical samples you see above was printed with the HP Laserjet Series II. The other is from the Mannesmann Tally® MT905. Both are reprinted here exactly as they came out of the printers.

But what might surprise you is the rather dramatic difference in the manufacturers' suggested retail prices.

The Mannesmann Tally laser is \$700 less. Yet it offers the same high quality output, lowers operating costs 25 percent, and prints at six pages per minute.

The MT905 comes with the same resident type fonts as HP, accepts standard HP font cartridges, and lets you choose optional memory upgrades from one to four megabytes.



MT905 Specifications

- Technology: scanning laser.
- Print Speed: 6-pages per minute.
- Resolution: 300 x 300 dpi.
- Emulations: HP Series-II. [optional emulations: Epson®, IBM® Proprinter, & Diablo 630.]
- Standard I/Os: Serial & parallel.
- Memory: 512K. [upgrades: 1, 2, & 4 megabytes.]
- Typefaces: Courier medium & bold, line printer, accepts standard HP font cartridges or any downloadable font in HP-format, 6-resident fonts + 2 font cartridge slots.
- Paper Handling: 250-sheet input & output bins. Manual feed handles single sheets, envelopes, transparencies, and labels.
- Workload: 4,000 pages-per-month.
- Suggested Retail: \$1,995.

For more convenient paper handling, the universal paper cassette holds letter, legal, and international sizes, plus up to 15 standard envelopes. You can choose face-down output to keep long documents in the right order. And the manual feed lets you print labels or transparencies.

So any way you figure, the answer still comes up the same. The Mannesmann Tally laser looks perfect. And so does the price.

For the name of your nearest dealer, call the toll-free number listed below.

MANNESMANN TALLY

1-800-843-1347

Ext. 348

Epson and IBM are registered trademarks.

See us at PC EXPO Booth #128

Circle 311 on Reader Service Card (DEALERS: 312)

**You Want A Laser Printer
With Faster Processing Speed,
Sharper 400 dpi Resolution
And More Powerful Functionality.
But You Think
You Can't Afford It.**

BEST



Complete 386 SYSTEM

- 80386-20 MHz CPU
- Support 80287, 80387 & WEITEK processor
- Six 16 Bit, Two 8 Bit BUS
- 1 MB RAM (Expandable 2,4,8 MB on board), 32 Bit
- RAM Architecture (Interleaved Page Mode)
- AMI Bios
- Realtime Clock/Calendar
- 1.2 MB Floppy Drive
- Fast 1 to 1 Interleaved Hard Disk Controller
- VGA Adapter & VGA Monitor
- 80 MB Hard Drive (28"ms)
- 101 Enhanced Keyboard
- Vertical Case
- MS-DOS 3.3 GW Basic
- 1 Year Warranty
- Support: NOVELL/3COM/PC NET/LanLink/OS/2

\$2990

NEW MINI PORTABLE BEST-286 LCD

- 10 MHz 0 WAIT (12 MHz Option)
- 512 K RAM
- 1.2 M. Floppy Drive
- 30 MB Hard Disk (Seagate 138 28ms)
- 200 W DC Fan Power Supply
- Serial & Parallel
- Non-Glare LCD Screen
- Super Twist
- Built-In Back Light
- 640 x 200 Dots
- Weight 22 lbs
- Padded Soft Carry Bag
- Dimension 16" x 8" x 9"

\$1600



286 BABY MOTHER BOARD

- 10 MHz \$265
- 12 MHz \$295
- Mono Monitor \$79
- Fujitsu 101 Enhance Keyboard \$45
- EGA PLUS 640 x 480 (Paradise Compatible) \$139

PORTABLE CASE

- 9" Dual Amber Monitor \$359
- 200 W Power Supply

LCD CASE

- 640 x 200 Dots \$549



VTI-33 SYSTEM

- 8088-2 10 MHz
- 640 K RAM
- 2 360K Floppy Drive
- Serial, Parallel Port
- Clock, Calender
- AT Style Keyboard
- Build in Mono/Color Graphic
- MONO MONITOR
- MS-DOS 3.3, GW Basic

\$749

COLOR SYSTEM \$919

BEST-286 PORTABLE

- 10 MHz (12 MHz Optional)
- 512 K RAM
- One 1.2 MB Floppy Drive
- 7 Expansion Slots
- 200 W DC Fan Power Supply
- 9" Dual Amber Screen
- Mono or Color Graphic Card
- 2 Serial & 1 Parallel Port
- 84 Key Soft Tough Key Board

\$1115

BEST-88 PORTABLE \$845



VTI-55 SYSTEM

- 80286 8/12 MHz
- Award bios
- 640K-120 ns
- 1.2 MB Floppy Drive
- 40 MB Hard Disk Seagate
- ST-251 with NCL
- 2 Serial 1 Parallel
- Clock Calender
- 101 Enhance Keyboard
- ATI EGA Wonder Card
- EGA MONITOR
- MS-DOS 3.3, GW Basic

\$1799

MONO SYSTEM \$1499

One Year Warranty

CALL FOR QUANTITY PRICE

BEST COMPUTER INC.
5017 Telegraph Road
Los Angeles, CA 90022

MON - SAT 9:00 - 6:00 PACIFIC TIME
PRICE & SPEC. ARE SUBJECT TO CHANGE WITHOUT NOTICE

Circle 40 on Reader Service Card
(DEALERS: 41)

Tel: (213) 265-0900
Tech: (213) 265-0300
Fax: (213) 265-4234
Toll: (800)634-7920
Outside Cal.



Credit Card Purchase Subject to Service Charge.

Personal and Private

*How much security is enough
on a microcomputer?*

Peter Stephenson

Not all personal computers are on networks. But virtually all computers, networked or not, contain sensitive information that poses an open invitation to compromise. Think how easy it is for someone reasonably familiar with personal computers—and today, that's almost everyone—to walk up to an unattended machine and copy a client list, personnel files, or any other information that's usually considered private.

Are security measures on individual personal computers as important as anti-intrusion procedures on a network? Should the contents of a hard disk be kept as secure as paper files in a locked file cabinet? Many people think that security on a personal computer is too troublesome, too confusing, and too expensive.

None of these excuses is valid anymore. Security on a stand-alone personal computer is easy to install, use, and maintain. Often, adding a security program can actually simplify the computer's use by adding a comprehensive menu system. But is this necessary? If you have data that you would lock in a file cabinet were it on paper, you should

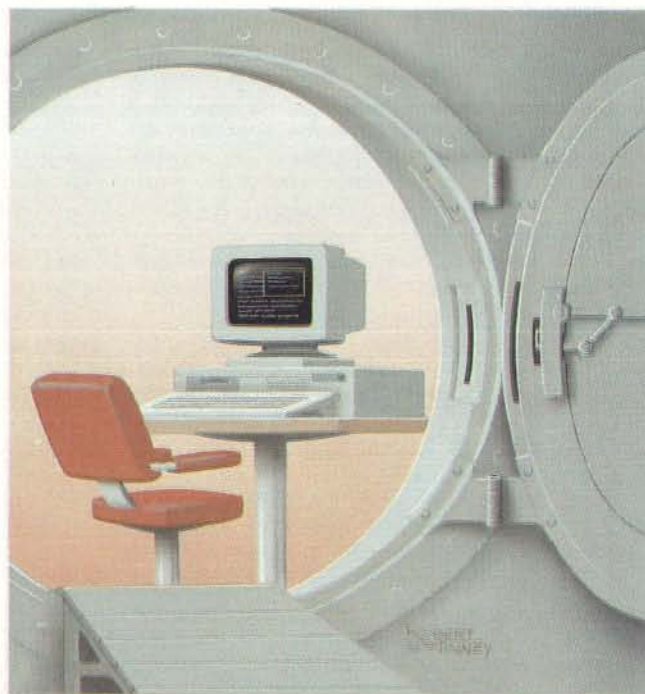

protect it with a good security program or an add-in board.

Although many software and hardware products are available to lock your microcomputer's electronic file cabinet, they all fall into a few functional categories. You can encrypt the data on your hard disk, prevent access to the data in the first place, and watch active files for viral contamination that could damage or

compromise data. Which of these approaches (or combinations thereof) you select will depend on how secure your data needs to be and how open your computer is to outside intrusion. (For a discussion of issues affecting a data center, see the text box "The Small Data Center" by Bob Brown on page 286.)

Keeping It Simple

Encrypting data files, such as word processing documents, databases, and spreadsheets, is the simplest line of defense. The casual snooper can't easily read encrypted data, but a determined data thief can often decrypt your files. The degree of encryption simply serves to slow down the malefactor in many cases. (For more details on encryption, see "Secret Codes" by Asael Dror on page 267.)

One of the fastest and least expensive examples of simple file encryption is File Encrypt from Wisdom Software. At \$69.95, it uses the Data Encryption Standard (DES) to encrypt files simply and quickly. File Encrypt is a single-key conventional cryptosystem written in assembly language and running in both DOS and OS/2 protected mode.

continued

The Small Data Center

Bob Brown

Security used to be pretty simple in the small data center with a mini-computer or small mainframe. The data center manager kept the computer room locked and used passwords to control access to data. Often the security policy was little more than an ad hoc collection of procedures. Widespread adoption of microcomputers in corporate and departmental computing has added new complexities to security management. Wise data center managers will review their procedures and develop a written security policy.

The principal reason for developing a security policy is to use it as a tool for communication. A formal policy will communicate your expectations to your staff, to the users of the computing facility, and to corporate management.

The development of a security policy necessitates a risk analysis; you can't determine how to deal with risks until you know what they are. Particularly in small organizations, if a risk analysis has been undertaken at all, it is likely to be out of date.

Finally, development of a security policy will allow threats to be dealt with proactively rather than reactively. For each identified threat, the policy should describe not only the protections to be put in place but also the actions that will be taken if the threat is realized. A security policy will serve as a damage-control guide if the worst happens.

The introduction of microcomputers into corporate and departmental data

processing has made a difference. The central computer is generally in a secure location—often in its own locked room. Programs and data are backed up on a regular basis. Transaction-logging software also can provide both an audit trail and another level of backup. Data access usually is controlled by passwords; often the password system is centrally administered, so, in effect, the data center manager controls all access. But even if these controls are actively in use, microcomputers have rendered them less effective.

The Trouble with Microcomputers

The two characteristics microcomputers have that make them so useful are local data storage and local data processing. These same two characteristics are also responsible for most microcomputer-caused security headaches.

Local data storage creates a requirement for backups in the various locations where the information is stored. And, if a microcomputer user has a floppy disk or a modem, data can be exported from or introduced into a system of microcomputers without any possibility of centralized control. It's highly likely that the manager responsible for central computing won't even know what data is stored on the microcomputers in the organization.

The problem with local data processing is one of quality control. Professional programmers are usually subject to a set of management practices and

testing guidelines that attempt to verify their work. Despite the formal quality control implemented by centralized data processing, users tend to view new and changed programs with a healthy dose of skepticism. This outlook provides an informal second level of verification. Yet these same users will set up a database or spreadsheet, or even write complete programs, and then rely on the results even though there has been no formal testing or quality assurance.

Analyzing the Risks

In analyzing the risks inherent in using microcomputers, you must consider not only the cost of the damage if a risk is realized, but the likelihood of the risk. Greatest attention should be paid to those risks that are both likely and costly if realized.

Don't forget that the most likely and potentially costly risks are those of human error. There's no limit to the kinds of errors people can make, and you can't guard against all of them. But if you implement a well-thought-out security policy, it will allow recovery from all but the very worst of these.

Probably the largest risk area inherent in the use of microcomputers is the ease with which machine-readable data can be manipulated. Data can be removed from the system, given to unauthorized people, and even destroyed. Some companies have tried to attack the data removal problem with LANs and diskless workstations. Getting rid of

Using File Encrypt is simplicity itself. After starting the program by typing FE and responding to the prompts, you only have to type ENCRYPT, DECRYPT, or SCRATCH. It will prompt you for input and output filenames and path names. Once a file is encrypted, you can only read it if you have the correct key. If you wish to have the original plaintext file destroyed, File Encrypt will do so at the end of the encryption process.

To return the encrypted file to its original plaintext state (i.e., remove the encryption permanently), you issue the DECRYPT command. To erase the file completely, you use the SCRATCH command. Unlike the DOS DELETE command, SCRATCH first deletes the file and then overwrites it with zeros. Thus,

once you have SCRATCHed it, you can never recover it. Virtually all competent security products use this method of erasing files.

A variation on the file-encryption theme is provided by Lattice's SecretDisk II. This program not only encrypts the data you select, it creates invisible "drives" where it stores the encrypted files. You can encrypt files using either the DES or Lattice's proprietary FAST data encryption. The advantage of FAST is, as you might think, its speed.

SecretDisk II's invisible logical drives contain only encrypted data in hidden system files. Using it requires installing device drivers in the CONFIG.SYS file. These device drivers create the virtual drives with all the sector-size character-

istics of a normal DOS partition. SecretDisk II's entire process is menu-driven using Lotus 1-2-3-like menus.

A single password locks and unlocks the secret drives. Once a drive is unlocked, you can access its contents. Even if an intruder managed to discover the existence and location of the secret drives with a disk-maintenance utility, the files would still be encrypted and, thus, presumably safe. SecretDisk II is a single-key system.

A companion product, the SecretDisk II Security Administrator, is a set of utilities that lets you master-key a secret disk. If someone left your organization or forgot a password, you could unlock the files and assign a new key. The Security Administrator also lets you customize

floppy disk drives reduces exposure to data theft. However, "LAN leaks" can be an even bigger problem. An authorized user can download data from the central computer and then store it on the LAN server in such a way that it's available to others who would otherwise not have access to it. This type of security failure is more likely to be the result of an innocent mistake than of malice.

The widespread use of dial-up data communications creates another area of concern. Any small computer with an accessory slot or serial port can be equipped with a modem. At 2400 bps or more, relatively large amounts of data can be exported (or imported) in a short time. The same modem that's used to transmit payroll information to a service bureau can transmit to someone's home computer or to a competitor. Unlike the LAN leak, unauthorized transfer of data via modem is not likely to be accidental.

Programs are as vulnerable to theft as data, perhaps even more so. If someone you work with is in the habit of trading stolen software with others, it's possible that a program for which you paid hundreds or even thousands of dollars could wind up in someone else's hands. Even if that doesn't happen, there is another risk: Software licenses seek to impose an obligation on the buyer to protect the software from theft. A software publisher that finds an identifiable copy of its program in unauthorized hands may try to collect financial damages from

the original buyer.

Unauthorized introduction of programs or data is as risky as unauthorized removal. The presence of stolen copies of programs on a company's computer leaves the company vulnerable to lawsuits and perhaps to prosecution. Unauthorized introduction of programs also provides a point of entry for malicious programs—viruses, worms, and Trojan horses—which can result in damage to data or even equipment. The presence of stolen data like bids or customer lists will almost certainly lead to legal action if it is discovered.

Physical security deserves consideration, too. The biggest problem is backup, and it is here that a LAN can help. If all critical or frequently changed files reside on a LAN server, the same person who runs the backups for the minicomputer or mainframe can back up the server. In fact, some server programs can run on certain minicomputers, using the disks for microcomputer data storage.

Microcomputers, like any expensive piece of office equipment, should be protected from theft or damage. Keeping them out of public areas is one of the best forms of protection. Simple equipment locks will prevent surreptitious removal and "grab-and-run" thefts.

Developing the Policy

Once you've analyzed the risks inherent in the use of microcomputers, you're ready to commit to a security policy.

Spend the most effort on those risks that are both likely and costly. Consider how these risks can be minimized, and also the appropriate response when a risk is realized. Be reasonable in the requirements your policy imposes; unreasonable demands will be ignored or circumvented, and they can be worse than no policy at all. Keep in mind that what's reasonable for a defense contractor, a bank, or a hospital might be unreasonable for other kinds of businesses.

Formalize the policy in writing in a single document. The collection of procedures that may have been enough for a centralized data center is not sufficient for distributed computing with microcomputers. The written policy should be given to everyone who could be affected by it.

Distributing the policy isn't the end of the job. It must also be kept up-to-date. The introduction of new technology such as LANs, removable hard disks, or optical storage may create new risks or obviate old ones. Changes in business practices may change the assessment of risks or the responses to risks realized. Regular review will ensure that the policy keeps up with the changing environment.

Bob Brown is associate executive director for information systems at the Georgia Medical Care Foundation in Atlanta, Georgia. He can be reached as "bbrown" on BIX, where he moderates the data.center conference.

SecretDisk II control panels; thus, you can limit the choices the program presents. Probably the most important use of this feature is its ability to disallow the DELETE command. When you remove DELETE from the control panels, it's impossible for someone to accidentally delete files on a hidden drive.

Several products also exist that facilitate secure transmission of data between two modems, including both software and integrated secure modems. One of the best of these is MailSafe from RSA Data Security.

Secure transmission of point-to-point traffic has three requirements. First, you must guarantee that what is received is what was sent. This ensures that data has not been intercepted and altered en route.

Second, you need to determine the identity of the message's author. And third, you must ensure that the traffic is secure and private while in transit. MailSafe provides these three safeguards in software that resides at both ends of the communications link.

Because more than one user must have access to the secure data, MailSafe uses a system of public and private keys. The users who will send secure data use a public key to verify the recipient's digital signature and encrypt traffic for transmission. The recipient uses a private key to sign files and decrypt the received secure messages.

MailSafe uses a system of menus to select and secure files for transmission. The process is kept as simple as possible

with allusions to everyday office functions. The sender creates public and private keys using the KeyGen utility. This process also installs user passwords. Passwords can be up to 80 characters long. MailSafe does not use the password to generate a key. Instead, the KeyGen utility automatically creates new keys. You can create new keys at any time. MailSafe also supports digital signatures.

MailSafe also allows you to share public keys. If two users want to encrypt files for mutual use, they can accomplish this by "certifying" their public keys to each other. Consequently, although neither one knows the other's password or key, secure messages can pass back and forth

continued

between them. MailSafe can be used on machines shared by several users without compromising any individual user's secure data.

Denying Access

Virtually all security experts agree that the best way to protect sensitive data residing on a computer is to deny access to the computer. While data encryption provides a certain measure of security, encryption works best as part of an overall security program that includes barriers to intruders. There are two ways to erect these barriers: in hardware and in software.

Software systems designed to thwart data thieves are the easiest to install and use but may allow determined intruders entry through so-called "back doors." One software security system that closes most loopholes is Watchdog from Fischer International Systems. Watchdog is one of the best-known software security programs.

The easiest way to defeat a software program is to bypass the boot disk and boot from a separate, independent disk. Watchdog prevents that by forcing you to boot from a predetermined drive, usually the hard disk drive. From the time that you log on, you are placed in a menu system that displays your authorized directory areas. Areas may be private or shared, allowing multiple users to use the same computer without danger of compromising personal data.

Watchdog assigns permission levels, much as in a LAN, to govern reading, writing, creating, and deleting files, as well as using DOS commands. Permission levels can be set for the system, for each area, and for each user. Files within secure areas are automatically encrypted using Watchdog's proprietary encryption algorithm. Finally, Watchdog provides an audit trail of all system activities by user.

Other features in Watchdog provide convenience as well as security. For example, a mailbox system allows secure messaging among those who share a machine. You can lock out the DOS FORMAT command for certain privilege levels, minimizing the risk of accidental or malicious reformatting of the hard disk. And a system library utility lets several users access shared data efficiently.

However, software intrusion barriers may fall to skilled and persistent intruders. Watchdog, for example, uses a proprietary encryption algorithm that may or may not be susceptible to tampering. The best possible protection against all

forms of security breaches is a combination of hardware and software security. Watchdog Armor adds that additional level of protection.

Armor is a half-card that works with Watchdog software to add several new security features and speed up many existing ones. The most obvious addition is the ability to absolutely designate the computer's boot drive. If any attempt is made to bypass the designated drive, Watchdog software kicks in immediately and cannot be bypassed. Armor also provides the option of DES encryption that resides on the board in firmware. This arrangement materially speeds up DES's encrypt/decrypt process. Armor also makes the audit trail's system clock completely tamperproof.

Installing Watchdog and Watchdog Armor is quite simple, and multiple I/O address choices for the board are available. A complete administrator's guide is part of the Watchdog package, and there are a number of administrative utilities.

Perhaps the most intensive hardware security device comes from American Computer Security Industries. ACSI has provided security products for government agencies for several years and has recently begun to provide its "industrial-strength" COMPSEC-II security product to commercial customers. COMPSEC-II is a half-card device that provides a smorgasbord of security and security-management features.

In addition to the features provided by Watchdog Armor, COMPSEC-II offers protection of mainframe-access channels, automatic encryption of data being archived to tape backup systems, copy protection of local files, site-license control, secure notepads, electronic signatures, time-zone control, and message authentication using the DES-based message authentication code (MAC) as specified by the National Bureau of Standards.

Time-zone control, along with the secure clock, allows you to limit the times and durations of individual user access. You can force users to change passwords periodically. COMPSEC-II also interfaces with many biometric devices, such as fingerprint readers.

In fact, the computer stays protected even if the COMPSEC-II board is removed. Should an intruder choose to disable the hardware by taking the card out of the computer, drive C ceases to exist as a valid path. Even booting from drive A won't enable DOS to recognize that the computer is configured for a hard disk drive. The system is menu-driven and reasonably transparent to individual use.

A second concern, beyond compromising sensitive data, is the introduction of a virus or other destructive program into a personal computer. COMPSEC-II has some features that greatly limit the potential for such damage. You can examine files using cyclic redundancy checks. Files in a directory are subjected to an initial CRC when you know they are "clean." Future periodic CRCs compare current to clean readings and warn you of suspected alterations.

You can make drive A or B unusable to all but those with required privilege levels. Since COMPSEC-II's secure kernel mediates all system transactions, you can take steps to ensure that only a limited number of users can introduce new programs (which may be Trojan horses containing a virus or worm) into the secure system.

Putting It All Together

The Immune System, also from ACSI, is a turnkey 80286-class computer completely outfitted, according to its developer, to protect you "against viruses and all other internal and external threats to your system and data."

The Immune System, at \$2995, contains all the features associated with COMPSEC-II, as well as other security features aimed at controlling access through COM ports and mainframe gateways. The computer sports a 12.5-MHz 80286 microprocessor, 1 megabyte of RAM, one parallel and two RS-232C serial ports, a high-density floppy disk drive, and a 40-megabyte hard disk drive. It comes completely configured for secure operation and pretested for virus contamination. Although it doesn't include a display, it does incorporate a Hercules Graphics Controller-compatible monographic card, and the computer is EGA-, CGA-, and VGA-compatible. The Immune System, like other ACSI products, uses the DES for data encryption.

What is the best response to the potential for security breaches? The intensity with which you choose to protect your data may depend on what you perceive its value to be. Today, when access to computer data is simple and virtually universal, proprietary information may be as easy to steal as copying a disk. Security systems are becoming not just easy to use and maintain, but also real enhancements to productivity without the expected inconvenience. ■

Peter Stephenson is a freelance author and consultant. He can be reached on BIX as "pstephenson."



The 20MB Tandy® 1400 LT

Hard disk, will travel.

Next business trip, take your office with you!

The Tandy 1400 LT offers you the power of a desktop PC—in a package small enough to fit on an airline tray table. When configured with a 20MB hard drive, the 1400 LT lets you transport a library of software and data—without taking a deskload of materials along for the ride. Then there's the convenience of operation

that only a hard drive can provide.

The versatile Tandy 1400 LT was designed with your

needs in mind. With a removable, rechargeable battery pack built in—and spares available—you'll never be without computing power!

Standard equipment includes 720K 3 1/2" drive and 768K RAM—ample memory to run powerful, industry standard MS-DOS® based programs. A high-resolution,

“supertwist” backlit crystal display gives you the same clarity as a full-sized monitor.

Speaking of full-sized monitors, you can easily attach an RGB color display, standard keyboard and printer to the 1400 LT for desktop convenience.

Don't settle for less than desktop performance from your laptop computer. Come in to your nearest Radio Shack today and discover the 20MB Tandy 1400 LT.



Rechargeable battery.



Add accessories for desktop convenience.



Ready to go!

Tandy Computers: Because there is no better value.™

MS-DOS/Reg. TM Microsoft Corp.

Circle 232 on Reader Service Card

Radio Shack®
The Technology Store™
A DIVISION OF TANDY CORPORATION

JUNE 1989 • BYTE 289

The Safety Zone

These products provide various combinations of security features, such as password protection, access control, boot protection, encryption, virus protection, and audit trails, via a half-card and/or software. Prices shown are low-end prices. An^M following the price indicates Mac compatibility. Others are DOS compatible.

ACE!.....about \$300
(Access Control Environment)
Casady & Greene, Inc.
P.O. Box 223779
Carmel, CA 93922
(408) 624-8716
Inquiry 984.

Access.....\$129.95
Access II.....\$165
Access II+.....\$175
Microlok.....\$79.95
Kinetic Corp.
240 Distillery Commons
Louisville, KY 40206
(502) 583-1679
Inquiry 985.

Antidote.....\$60 (U.S.)
Quaid Software, Ltd.
45 Charles St. E, Third Floor
Toronto, Ontario
Canada M4Y 1S2
(416) 961-8243
Inquiry 986.

AT-Lock.....\$360 (U.S.)
Larnen Tasar, Inc.
1188 Ostler Court
Mississauga, Ontario
Canada L5C 3G6
(416) 849-6630
Inquiry 987.

Bit-Lock.....\$45
Compu-Lock.....\$117
Key-Lok.....\$28
Microcomputer Applications
3167 East Otero Cir.
Littleton, CO 80122
(303) 922-6410
Inquiry 988.

Certus.....\$189
FoundationWare
13110 Shaker Sq.
Cleveland, OH 44120
(216) 752-8181
Inquiry 989.

Citadel Security System.....\$195
Sentinel Security System.....\$465
Sector Technology
(A division of Polaris, Inc.)
5109 Leesburg Pike, Suite 900
Falls Church, VA 22041
(703) 379-1800
Inquiry 990.

Codename: Password.....\$79
Codename: Secure.....\$199
The Sergeant.....\$149
Digitech Telecommunications
342 Madison Ave., Suite 2010
New York, NY 10173
(212) 557-7230
Inquiry 991.

Codesafe.....\$25
Datasafe.....\$125
Demosafe.....\$25
Logsafe.....\$250
ViruSAFE.....\$150
Comnetco, Inc.
29 Olcott Sq.
Bernardsville, NJ 07924
(201) 953-0322
Inquiry 992.

Coffee Break.....\$29.95
CPU Lock II.....\$69.95^M
PC Lock IV.....\$299
MPPI, Ltd.
2200 Lehigh Ave.
Glenview, IL 60025
(312) 998-8401
Inquiry 993.

COMPSEC-II.....\$325
The Immune System.....\$2995
American Computer Security Industries
112 Blue Hills Court
Nashville, TN 37214
(615) 883-6741
Inquiry 994.

Cortana.....\$295
OnGuard.....\$295
PrivacyPlus.....\$195
United Software Security, Inc.
8133 Leesburg Pike, Suite 800
Vienna, VA 22182
(800) 892-0007
(703) 556-0007
Inquiry 995.

Crypt.....\$11.95
Pico Publishing
305 Second St., SE
512 Paramount Building
Cedar Rapids, IA 52401
(319) 362-6964
Inquiry 996.

CryptoGard.....\$500
Advanced Computer Security Concepts
4609 Logsdon Dr.
Annandale, VA 22003
(703) 354-0985
Inquiry 997.

Cryptolock.....\$79
Commcrypt, Inc.
11005 Piney Meetinghouse Rd.
Rockville, MD 20854
(301) 299-7337
Inquiry 998.

Data Lock.....\$49.95
Pride Software Advancement Corp.
3575 Northwest 31st Ave.
Oakland Park, FL 33309
(305) 731-1087
Inquiry 999.

Data Physician.....\$149
Digital Dispatch, Inc.
55 Lakeland Shores
Lakeland, MN 55043
(800) 221-8091
(612) 436-1000
Inquiry 1000.

DataSafe.....\$99
Trigram Systems
5840 Northumberland St.
Pittsburgh, PA 15217
(412) 422-8976
Inquiry 1001.

DataSentry.....\$99
Eve.....\$79 each^M
(minimum order: 10)
Sentinel-C.....\$39 each
(minimum order: 10)
SentinelPro.....\$39 each
(minimum order: 10)
SentinelShell.....\$39 each
(minimum order: 10)
Rainbow Technologies
18011-A Mitchell S
Irvine, CA 92714
(714) 261-0228
Inquiry 1002.

DES-PAC.....\$249
Hawkeye Grafix
P.O. Box 1400
Oldsmar, FL 34677
(813) 855-5846
Inquiry 1003.

Disk Watcher.....\$99.95
RG Software Systems, Inc.
2300 Computer Ave., Suite I-51
Willow Grove, PA 19090
(215) 659-5300
Inquiry 1004.

Drivelokr.....\$99
Glencoe Engineering
721 West Algonquin Rd.
Arlington Heights, IL 60005
(312) 364-7638
Inquiry 1005.

Dr. Panda Utilities.....\$79.95
Panda Systems
801 Wilson Rd.
Wilmington, DE 19803
(302) 764-4722
Inquiry 1006.

Empower.....\$395^M
Magna
2540 North First St., Suite 302
San Jose, CA 95131
(408) 433-5467
Inquiry 1007.

Everlock.....\$495
Az-Tech Software, Inc.
305 East Franklin
Richmond, MO 64085
(800) 227-0644
(816) 776-2700
Inquiry 1008.

File Encrypt.....\$69.95
Wisdom Software, Inc.
P.O. Box 460310
San Francisco, CA 94146
(800) 456-7276
(415) 566-0754
Inquiry 1009.

iSECURE Cryptosystem.....\$295
iMANAGE Software Co.
P.O. Box 31151
Houston, TX 77231
(713) 721-7100
Inquiry 1010.

Key
(price not yet available)
Technical Communications Corp.
100 Domino Dr.
Concord, MA 01742
(617) 862-6035
Inquiry 1011.

LOCKIT I.....\$69.95
LOCKIT II.....\$79.95
LOCKIT III.....\$89.95
Security Microsystems Consultants
215 Cromwell Ave.
Staten Island, NY 10305
(800) 345-7390
(718) 667-1019
Inquiry 1012.

- MacSafe**\$149.95^M
NightWatch\$149.95^M
 Kent Marsh Ltd., Inc.
 1200 Post Oak Blvd., Suite 210
 Houston, TX 77056
 (800) 325-3587
 (713) 623-8618
Inquiry 1013.
- MagLock**\$89
 Flinder Software Laboratories
 340 Harris Hill Rd.
 Williamsville, NY 14221
 (716) 693-0584
Inquiry 1014.
- Mailsafe**\$250
 RSA Data Security, Inc.
 10 Twin Dolphin Dr.
 Redwood City, CA 94065
 (415) 595-8782
Inquiry 1015.
- Multi-Function Encryptor
 and Remote Control**\$695
 Secure Telecom, Inc.
 P.O. Box 70337
 Sunnyvale, CA 94086
 (408) 992-0572
Inquiry 1016.
- N'cryptor**\$39.95^M
 Mainstay
 5311-B Derry Ave.
 Agoura Hills, CA 91301
 (818) 991-6540
Inquiry 1017.
- PC/Audit**\$299.95
 North Edge Software Corp.
 289 Western Ave.
 Essex, MA 01929
 (508) 768-6100
Inquiry 1018.
- PCBoot**\$250
ThumbScan\$1195
 ThumbScan, Inc.
 335 Eisenhower Lane S
 Lombard, IL 60148
 (312) 932-8844
Inquiry 1019.
- PC/DACS**\$249
 (Data Access Control System)
 Pyramid Development Corp.
 20 Hurlbut St.
 West Hartford, CT 06110
 (203) 524-9832
Inquiry 1020.
- P/C Privacy:
 Personal/Confidential**
 DOS version\$140
 Macintosh version\$95^M
 MCTel, Inc.
 5060 Parkside Ave., Suite 1300
 Philadelphia, PA 19131
 (215) 879-3819
Inquiry 866.
- PC-Safe (SafeWord)**
 For supervisor module\$395
 For each user\$275
PC-Safe II (SafeWord)
 For supervisor module\$395
 For each user\$275
SafeWord AccessCard\$37
Terminal-Safe (SafeWord)
 For supervisor module\$495
 For each user\$375
**UNIX-Safe
 (SafeWord)**\$3250/25 users
 Enigma Logic, Inc.
 2151 Salvio St., Suite 301
 Concord, CA 94520
 (415) 827-5707
Inquiry 867.
- PC Security Board**\$159
 Black Box Corp.
 Mayview Rd. at Park Dr.
 P.O. Box 12800
 Pittsburgh, PA 15241
 (412) 746-5500
Inquiry 868.
- Protec**\$195
 Sophco, Inc.
 3210 Valmont
 Boulder, CO 80301
 (303) 444-1542
Inquiry 869.
- Ridge Reader MINT
 11**\$3300
**Ridge Reader MINT
 21**\$3300
 Fingermatrix, Inc.
 30 Virginia Rd.
 North White Plains, NY 10603
 (914) 428-5441
Inquiry 870.
- Safetalk**\$295
X-Lock 10\$299
X-Virus\$99
 InfoSafe Corp.
 2137 Flintstone Dr.
 Tucker, GA 30084
 (404) 491-8044
Inquiry 871.
- SecretDisk II**\$79
**SecretDisk II Security
 Administrator**\$500
 Lattice, Inc.
 2500 South Highland Ave.
 Lombard, IL 60148
 (312) 916-1600
Inquiry 872.
- SecuriKey**\$25-\$45
 Micro Security Systems, Inc.
 4750 Wiley Post Way, Suite 180
 Salt Lake City, UT 84116
 (800) 456-2587
Inquiry 873.
- Security Guardian**\$250
 Command Software Systems
 28990 Pacific Coast Hwy.,
 Suite 208B
 Malibu, CA 90265
 (800) 423-9147
 (213) 457-1789
Inquiry 874.
- Security Library**\$125
 With source code\$250
 The Coder's Source
 541 Main St., Suite 412
 South Weymouth, MA 02190
 (800) 255-4659
 (617) 331-0800
Inquiry 875.
- Sentinel**\$295^M
 SuperMac Technology
 485 Potrero Ave.
 Sunnyvale, CA 94086
 (408) 245-2202
Inquiry 876.
- SoftSafe**\$99
 Software Directions, Inc.
 1572 Sussex Turnpike
 Randolph, NJ 07869
 (201) 584-8466
Inquiry 877.
- SuperKey**\$99.95
 Borland International, Inc.
 1800 Green Hills Rd.
 P.O. Box 660001
 Scotts Valley, CA 95066
 (408) 438-8400
Inquiry 878.
- SuperLock**\$285
SuperLock/Mac\$285^M
 Softguard Systems, Inc.
 710 Lakeway, Suite 200
 Sunnyvale, CA 94086
 (408) 773-9680
Inquiry 879.
- System Manager**\$595
 Porak Computing Services
 2613 Flintridge Dr.
 Colorado Springs, CO 80918
 (719) 593-1187
Inquiry 880.
- TouchSafe**\$1795
 Identix, Inc.
 510 North Pastoria Ave.
 Sunnyvale, CA 94086
 (408) 739-2000
Inquiry 1155.
- UNlock MasterKey**\$99.95
 PCEasy, Inc.
 7570 South U.S. Highway 1
 Hypoluxo, FL 33462
 (407) 547-0790
Inquiry 1156.
- Unprotect for BASIC** ...\$19.95
 Software Masters (IN)
 6352 North Guilford Ave.
 Indianapolis, IN 46220
 (317) 253-8088
Inquiry 1157.
- VaccinatePlus**\$69.95
 Computer Integrity Corp.
 P.O. Box 17721
 Boulder, CO 80308
 (303) 449-7377
Inquiry 1158.
- Vaccine**\$129.95
 WorldWide Data Corp.
 40 Exchange Place, 15th Floor
 New York, NY 10005
 (212) 422-4100
Inquiry 1159.
- Watchdog**\$295
Watchdog Armor\$150
 Fischer International Systems
 Corp.
 4073 Merchantile Ave.
 Naples, FL 33942
 (813) 643-1500
Inquiry 1160.
- XPack**\$99
 Inset Systems, Inc.
 71 Commerce Dr.
 Brookfield, CT 06804
 (203) 775-5866
Inquiry 1161.

With so much to do here...

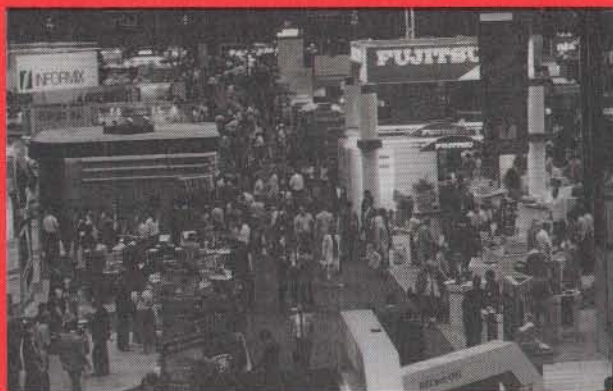

Register Today!

The Seventh Annual PC EXPO in New York, June 20-22

at the Jacob Javits Center, is simply your best opportunity of the year to stay in touch with a new era in computing, to see thousands of new products reflecting the latest technology and current state of the art.

And of course you won't want to miss the renowned PC EXPO Seminar Series, highlighted by **Connections 89** and a new Mac Track exploring today's business challenges concerning the Macintosh. For six years, the show has helped computer professionals like you make your most important computer purchasing plans—from evaluating platform systems to reviewing operating systems to selecting communications standards. With major decisions like these to be made, why wait in line?

MORE THAN 500 EXHIBITORS!

Acer Technologies • Action Technologies • Adobe Systems • Advanced Transducer Devices • Allstar Microsystems • Alps America • Altos Computer Systems • AMDEK • American Micronics • American Power Conversions • Anderson Soft-Teach • Applied Business Technology • Applied Creative Technology • ApTech • Archive Corp. • Ashton-Tate • Aspen Ribbons • AST Research • Atlantic Tech • AT&T • Attachmate • Austin Laser Charge • Avery • Bandy Inc. • Banyan Systems • Barr Systems • BDT Products • Belkin Components • Berkeley Corporate Services • Boca Research • Bondwell Industrial • Borland International • Brightbill-Roberts • Brown Bag Software • Business Machines Security • BYTE • Caere • Cahner's • Canada, Department of External Affairs • Canon U.S.A. • CBIS • CCS • CES Training Corp. • Chance Logic • Channel Computing • Citizen America • Clary • Clipper • CMP • The Cobb Group • COMM-TALK • Commcrypt • Commodore • Compaq • The Complete PC • Compu Cover • Computer Accessories • Computer Applications Learning Center • Computer Associates • Computer Expressions • The Computer Factory • Computer Furniture Center • Computer Hot Line • Computer Maintenance Corp. • Conetic Systems • Conner Peripherals • Continental/Regent • Core International • Crosstalk Communications • CTA • Cybernetics • Data Access • Data-Tech Institute • DataEase • Datamedia • Datapoint • Dataproducts • Dataware • Dayna Communications • DEC Professional • Dell Computer • Delta Technology • Demar • Destiny Technology • Dialog Information Services • Diamond Flower • Digital Communications Assoc. • Digital Equipment Corp. • Digital Products • Digital Research • Dragonfly Software • Drive Phone • Dynamic Decisions • Dynamic Microprocessor Assoc. • Eastman Kodak • ECA Computer & Communications • ECN • EIT • Electrograph Sales • Emerald Systems • Enable Software • Epson America • Equinox Systems • Everex Systems • Excelan • Extended Systems • Facit • Fischer International Systems • Flagstaff Engineering • 47th Street Computer • FoundationWare • Fountain Technologies • Fox Software • Gateway Communications • GBC Technologies • General Power Corp. • General Technologies • Grid Systems • Group 1 Software • Harcom Security Systems • Hauppauge Computer Works • Haventree Software • Hayes • Hertz Computer • Hewlett-Packard • High-Tech Resources • Hitachi America • IBM • IDG • Imprimis Technology • Information Builders • Information Research • Informix Software • Inovatic • Intel Corp. • Interpreter • Iomega • Irwin Magnetics • Jog Computer Club • JWP • KAO • Karmich/Micro • Kelly Services • Key Systems • Key Tronic • KnowledgePoint • Krystaltech • KYE International • LAN Magazine • Laser's Edge • Lifetree Software • Lightspeed Technology • Liusk • Logitech • Lotus • Mannesman Tally • Mansfield Software Group • Manzana Microsystems • Map Info • Marketing Grafix • Media Technologies • Mega Knowledge • MegaData • Megasoft • Memorex Telex • Meridian Technology • Micro Palm Computers • Microdisk Services • Micrografix • Microlytics •

Micron Technology • MicroPerfect • MicroPro International • Microserv Technologies • Microsoft • Micro-systems Engineering • Microtek Lab • Microvideo Learning Systems • Mirro Computers • MIS Week • Mitsubishi • Modemsplus • M & T Publishing • N/Hance • Nantucket • National Micro Rentals • Natural Microsystems • NCR • NEC • Network & Communication Technology • Network Software Association • Norton-Lambert • Novell • Nviev • NYNEX • The Office Magazine • Official Airlines Guide • Okidata • OCI • Opticom • Oracle • Osborne/McGraw-Hill • Osicom Technologies • Output Technology • Pace • Palantir Software • Palisade • Pama Enterprises • PAN Overseas • Panasonic Industrial • Paperback Software • Para Systems • Parc Place Systems • PCLC • Peed Corporation • Pentax Teknologies • Percon Peripheral Connections • Performance Technology • Personal Computing Magazine • Peter Norton Computing • Pick Systems • Pivar Computing Services • Polaroid • Priam • Princeton Publishing Labs • ProBusiness • The Processor • Productivity Center • Professional Press • Publications & Communications • Publishing Technologies • Pyramid • Quadram • Qualstar • Quarterdeck • Quicksoft • QW Page • Radio Call • Reference Software • Regent Box • RELAY Communications • Ribner B.F. • Ricoh • Rose Electronics • Rupp Brothers • Saber Software • Samna • SAS • SBT • Scott, Foresman • Seagate Technology • Sears Business Center • Security Microsystems • Seiko Instruments • Sirex U.S.A. • Sitback Technologies • Small Computer Co. • Sofsearch • Softkey • The Software Group • Software Magazine • Software Masters • Software Publishing Corp. • Sorbus • SourceMate • Spectrum Concepts • Spread Information Sciences • Spencer Organization • Standard Microsystems • Star Micronics • STB • Storage Dimensions • STSC • Sunflex • Supercom Industrial • Symantec • Taft • Tandy • Techland BlueLynx • Tektronix • Telebyte Technology • Telex Communications • Texas Instruments • The Aldridge Company • Thomas-Conrad • 3Com • Tiara Computer Systems • TMLC • Toshiba America • Traveling Software • Tripp Lite Mfg. • Triton Technologies • TSSI Tech Service • Unisys • U.S. Micro Engineering • Vendex Technologies • Ven-Tel • Victory Enterprises • VIDEX • VisionGuard • Viziflex Seels • Wang Labs • Warner Computer Systems • Welcom Software Tech • Wells American • Weltec Digital • Westchester PC User Group • Westcorp Software Systems • Wink Data Products • WordPerfect • Wordworks • World Software • Wyse Technology • Xerox • XTREE • Zenith • Zenographics • Ziff-Davis

...plus scores of other industry leaders who are joining PC EXPO every day!

Why wait here?



SEMINAR SERIES

Keynote: David L. House, Senior Vice President, Intel Corporation 9:15 a.m. Tuesday

Tuesday, June 20

1. Computers on Wall Street
2. Introduction and Overview of Distributed Databases
3. Software 1990
4. OSI Standards
5. Macintosh as a Workstation
6. CASE Tools and Micro/Network Systems Development
7. Desktop Publishing from Soup to Nuts
8. OS/2: 10 Reasons to Switch, 10 Reasons Not To
9. A LAN Primer
10. Operating Systems: Beyond Multi-Finder
11. Alternate Bus Routes: A Discussion of Bus Options
12. Network Design
13. Mission-Critical Applications
14. Introduction to Telecom and Wide Area Networks
15. Installing, Training and Support for the Macintosh

Wednesday, June 21

16. Resource Sharing without Local Area Networks
17. The '486 Shockwave: What the Future Holds
18. Supporting Multiple Environments
19. Making Connections with LAN Bridges and Gateways
20. Application Development for the Macintosh
21. Manufacturers' Dealer Incentives Programs
22. Alternatives to Portions of OS/2 EE
23. Softline: Candid Comments from Industry Leaders
24. Workgroup Software: Are We There Yet?
25. Making Mac Connection in Corporate Environments
26. OS/2 Contenders: A Look at Other Operating Systems
27. Migrating Applications: Downsizing and Upsizing
28. Keeping Up with End-User Computing Demands
29. Making Connections with Micros and Minis
30. Desktop Publishing: DOS and Mac-Based Systems
31. Expert Systems: Tools and Applications
32. Project Management

33. Will dBase IV Revive the dBase Standard?
34. Network Management
35. Hypercard and the Macintosh: Fact or Fancy

Thursday, June 22

36. EISA Implementation: What It Will and Won't Do
37. Document Processing Instead of Desktop Publishing
38. PC Security: Protecting Real Assets
39. Making Connections from Micros to Mainframes
40. Macintosh Presentation Technology
41. The Proper Role of Systems Integrators
42. Wide Area Spreadsheets
43. Computer Languages and Utilities
44. OS/2 and Networking
45. Optical Storage: Available, Affordable and Erasable
46. Taking Graphics for Granted
47. Managing Software Development Products
48. Network Diagnostics—Tools and Techniques

WHY WAIT IN LINE? REGISTER TODAY!

7th Annual PC EXPO in New York June 20-22, 1989 Jacob Javits Convention Center

Fill out this form completely and mail before May 26 to avoid on-site lines.

BADGE FEES Check One:

- 1 Day Exhibits \$30 (Circle day: Tues., Wed., Thur.)
 2 or 3 Day Exhibits \$60
 Seminars \$95 (Good for all 3 days of seminars and exhibits)

Note: This form must be used in advance. It may not be used on-site.

Circle appropriate seminar numbers you wish to attend. All sessions are first-come, first-seated.

Tuesday	1	2	3	4	5	6	7	8	9	10	11	12	13	14	15
Wednesday	16	17	18	19	20	21	22	23	24	25	26	27	28	29	30
Thursday	31	32	33	34	35										

NAME _____

BUSINESS TITLE _____

COMPANY _____

CO. ADDRESS _____

CITY _____ STATE _____

MAIL STOP (if any) _____ ZIP _____

TELEPHONE _____

(Use one form per person; photocopy if necessary)

By attending PC EXPO, I consent to the use of photographs of me in any promotional materials related to the show and/or events.

Signed _____ Date _____

BADGE ORDERS FOR PC EXPO received by May 30 will be mailed by June 13. Late orders will be processed and held for arrival at the "Pre-Registered Attendee Counter" in the registration area. All registrations will be confirmed by PC EXPO. Registration fees must be in U.S. funds. Foreign mail orders (except Canada) must be received no later than May 23 and will be held at the "Pre-Registered Attendee Counter" for pick-up upon arrival. All registrations are non-refundable.

MAKE CHECKS PAYABLE TO PC EXPO and mail with completed registration form to: PC EXPO, P.O. Box 1026, Englewood Cliffs, NJ 07632. Credit cards and vouchers are not acceptable for advanced registration. Government and State Agency Purchase Orders will be accepted with completed registration form. Payments for purchase orders is due upon receipt of PC EXPO invoice.

Incomplete or improperly completed forms will be returned. Minors under the age of 18 may not register.

Check only your main job function from box below.

- | | | |
|----|------------------------------|------------|
| AA | Accountant | III |
| BB | Administrator | |
| CC | Consultant | |
| DD | Corporate Officer | |
| EE | Creative Arts (All) | |
| FF | Designer (All) | |
| GG | DP/WP Manager Operator | |
| HH | Engineer (All) | |
| II | MIS Director/Manager | |
| JJ | Programmer | |
| KK | Purchasing | |
| LL | Sales/Marketing | |
| MM | Scientist | |
| NN | Securities/Financial Analyst | |
| OO | Service Technician | |
| PP | Systems Analyst | |
| WW | Systems/Application Mgr. | |
| RR | Systems/Architect | |
| SS | Systems/Maintenance | |
| TT | Systems/Manager | |
| UU | Systems/Project Manager | |
| VV | Systems/Prototyper | |
| QQ | Other (specify) _____ | |

Check your co.'s main activity from section I or II.

TRADE RESELLERS

- | | | |
|----|--------------------------|----------|
| 1 | Computer Consultant | I |
| 2 | Computer Dealer/Retailer | |
| 3 | Computer OEM | |
| 4 | Office Products Dealer | |
| 5 | Service Vendor | |
| 6 | Software Developer | |
| 7 | Systems House | |
| 8 | Turnkey Vendor | |
| 9 | Value Adder | |
| 10 | Computer Distributor | |
| 11 | Other (specify) _____ | |

CORPORATE VOLUME BUYERS

- | | | |
|---|-------------------------|-----------|
| A | Accounting Firm | II |
| B | Advertising | |
| C | Banking | |
| D | Communication | |
| E | Construction/Architects | |
| F | Credit | |
| G | Education | |
| H | Engineering | |
| I | Government/Military | |
| J | Hospital | |
| K | Hotel | |
| L | Industrial Design | |
| M | Insurance | |
| N | Law Office | |
| O | Management Const. | |
| P | Manufacturing | |
| Q | Publishing | |
| R | Real Estate | |
| S | Research Development | |
| T | Retail Sales | |
| U | Securities Broker | |
| V | Transportation (All) | |
| W | Utility | |
| X | Wholesale/Retail Sales | |

PC-DOS: PULLING OUT THE STOPS

The latest versions of PC-DOS have features that speed up file access for applications

Fetchi Chen

Even though PC-DOS has been in existence for only seven years, it is the most widely used operating system. As a result of the variety of IBM PC hardware and application environments, DOS has evolved to provide options for improved performance. In versions 3.3 and 4.0, the design team implemented four new performance-enhancing mechanisms.

The first mechanism is the support of large buffers by using expanded memory, which provides an increase in performance for programs with large, random I/O files. You can now specify a maximum of 10,000 system buffers.

The second mechanism is the support of look-ahead buffers for sequential file processing. You can specify up to eight look-ahead buffers. This mechanism reduces the number of disk accesses for frequent sequential disk requests, improving sequential disk I/O without degrading random disk I/O.

The third mechanism is Fast Open, which caches file directory entries and provides a fast access to opening the files. The cache entries are managed using an LRU (least recently used) scheme. This mechanism is beneficial for files that are frequently opened and closed.

The fourth mechanism is Fast Seek, which caches file cluster information and also provides fast access to the file read and write requests. Compared to the file cluster information on the disk, the cache entries have a denser representation and can dynamically grow when more information is inserted. This greatly improves the performance of random I/O for large contiguous files. Both Fast Open and Fast Seek provide better granularity for the LRU management, as well as better utilization of memory.

Expanded Memory and Buffers

DOS 4.0 supports full functionality of LIM/EMS 4.0. DOS can now address memory beyond the 640K-byte limit. DOS accesses the expanded memory through a combination of an EMS device driver and an EMS-capable hardware adapter. The EMS driver maps a 16K-byte page frame onto the 16K-byte logical

page in expanded memory. The 16K-byte page frame is the unused address space between the 640K-byte memory and 1-megabyte memory. DOS uses page frame 255 as a window to extend its addressability.

As in earlier versions of DOS, the first parameter of the BUFFERS command in the CONFIG.SYS file specifies the number of system buffers needed for the file I/O. When you specify the /X option for the BUFFERS command in the newer versions of DOS, you can have as many as 10,000 buffers, equivalent to 5 megabytes of expanded memory.

The design team based the design of large buffers on two criteria. First, only 16K-byte system buffers can be addressed at the same time because of the restriction imposed by the 16K-byte page frame. Second, no matter how many buffers you specify, the buffer searching time must be bounded and fast. Because of these criteria, the team adopted a hash algorithm (see figure 1).

The hash table resides in conventional memory. The number of hash entries depends on what option is specified. If you use the /X option, all system buffers are created in expanded memory with each hash entry containing exactly 15 buffers. Since each buffer, including the header information, is 532 bytes, a 16K-byte logical page can map 30 system buffers of two adjacent hash entries. For example, the CONFIG command BUFFERS=50 /X creates four hash entries and 60 system buffers (two 16K-byte logical pages) in expanded memory. If you don't use the /X option, you can specify only up to 99 buffers, which DOS will create just within the conventional memory.

Hashing for Fast Buffers

In order to achieve a consistent performance improvement over all hash entries, the design team used an algorithm for making each hash entry contain almost the same number of buffers. In the algorithm on the next page, M is the number of buffers that the user specifies, H is the number of hash entries created, and N(H) is the number of buffers that hash entry H contains.

continued



H = 1

If $M < 30$, then $N(1) = M$ and return

$R = \text{remainder}(M/15)$ and $H = \text{quotient}(M/15)$

If R is 0, then set $N(1) \dots N(H)$ to 15 and return

$E = \text{remainder}(R/H)$ and $F = \text{quotient}(R/H)$

Set $N(1) \dots N(H)$ to $(15 + F)$

If E is not 0, add 1 to $N(1) \dots N(H)$

Return

The hash entry is composed of three fields: EMS Page, Buffer Head, and Dirty Count. EMS Page is the logical page number of the EMS handle, which must be mapped to page frame 255 before buffers of the referenced hash entry are accessed. Buffer Head is a doubleword segment offset pointer to the first buffer of the list. Dirty Count indicates the number of changed buffers per hash entry. To cope with the 16K-byte page-frame window and the EMS mapping overhead, DOS uses the LRU scheme to manage each circular list. That is, when a buffer is needed and no free buffer is available, DOS removes the buffer

not referenced for the longest time from the list. The algorithm for reading a disk sector is as follows:

$N = \text{remainder}(\text{sector number} / \text{number of hash entries})$

Map the EMS page of hash entry N to page frame

255 if /X is specified

Search the circular list for the sector

If the sector is found, make the buffer most recently used and return

If the sector is not found, find the LRU buffer, write it to the disk if changed, and free the buffer

Read the disk sector into the free buffer and make it the most recently used

Return

Figure 2 shows the performance test results from a PS/2 Model 60. The test created a 256K-byte file on the hard disk and did 12,800 random-sector reads and writes on the file. The best performance starts from BUFFERS = 500. This saturation

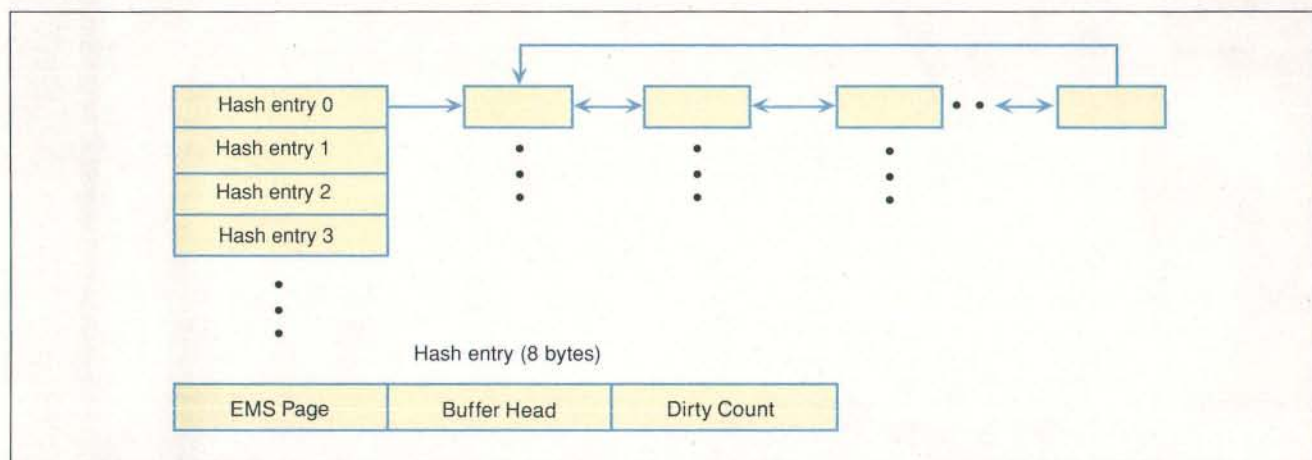

Figure 1: The structure of the information for large buffers consists of a hash table (in conventional memory). Each 8-byte entry in the table contains an extended-memory page number and a doubleword segment offset (address) of the first buffer in the list of 15 buffers that reside in the expanded memory. In addition, each table entry contains a Dirty Count of the number of changed buffers.

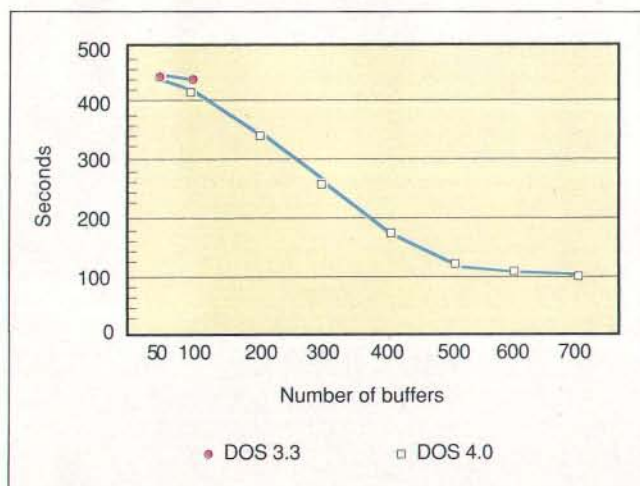

Figure 2: The performance improvements from using large buffers with 12,800 random-sector reads and writes on a 256K-byte file. The test was done on a PS/2 Model 60.

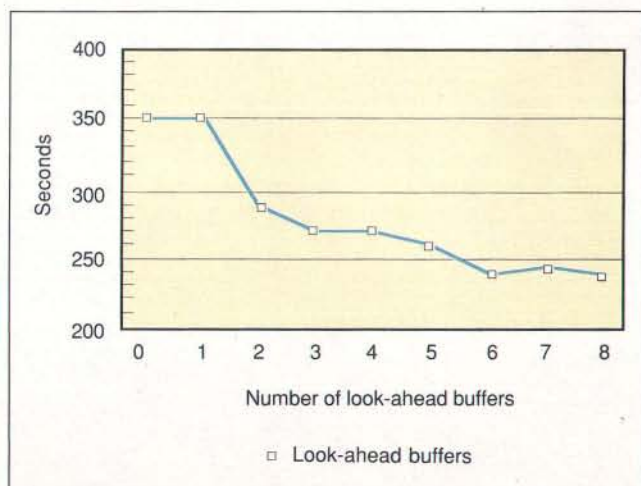

Figure 3: The performance improvements from using look-ahead buffers with 12,800 sequential-sector reads and writes on a 256K-byte file.

The intent of Fast Open is to provide a fast access to directory entries by caching them in memory.

point indicates that most sectors of the file are in system buffers and DOS can access data without reading the disk.

Look-Ahead Buffers

The purpose of look-ahead buffers is to read sectors ahead of the current disk sector of a sequential file access, thereby reducing the number of disk reads. The second parameter of the CONFIG.SYS BUFFERS command specifies the number of look-ahead buffers. You can specify up to eight look-ahead buffers. If you specify the value 3, DOS will create three look-ahead buffers in conventional memory.

When DOS reads disk sector 100 with three look-ahead buffers, it actually reads sectors 100, 101, and 102 with a single disk read. If DOS is requested to read sector 101 on the next access, it can retrieve the data from the look-ahead buffer without any physical disk access. To prevent random file-read degradation that would result from unnecessary look-ahead reads, DOS 3.3 and 4.0 use the following simple heuristic method. DOS always compares the current requested sector number, say C, with the previous requested sector number, say P. If $C - P$ is less than or equal to 1, DOS reads ahead; otherwise, DOS reads only sector C.

Figure 3 shows the performance test results from a PS/2 Model 60. The test created a 256K-byte file on the hard disk and did 12,800 sequential-sector reads and writes on the file. This test reads and writes from the beginning to the end of the file for 100 iterations. The random-files test for large buffers was also run to evaluate the effect of the heuristic method. The results indicate that look-ahead buffers greatly improve sequential I/O while not affecting the performance of random I/O.

Fast Open

As the name implies, the purpose of Fast Open is to rapidly open files. Each file on a disk is associated with a 32-byte directory entry that contains information about the file—for instance, Attribute, Date, Time, Size, and Starting location. A directory file is a special file that contains directory entries instead of data. On a call to open, DOS reads the file's directory entry from the disk sector into the system buffer so that subsequent reads and writes can use that information. But an application program frequently issuing open, read, write, and close to the same file can result in inefficient operations. First, in order to get a 32-byte directory entry, DOS needs to read one disk sector (usually 512 bytes). A four-level-deep file path name (e.g., A\B\C\D) can waste $4 \times (512 - 32)$ bytes in the system buffers, resulting in less accuracy of the LRU scheme used by the system buffers. Second, because of the limited number of buffers, the reads and writes performed after the file is opened may flush the buffer containing the directory entry and introduce the requirement of an additional disk read for the next reopen.

The intent of Fast Open is to provide a fast access to directory

continued



Reading
worth
writing
for.

If you're looking for some good reading, you've just found it. The free Consumer Information Catalog.

The Catalog lists about 200 federal publications, many of them free. They can help you eat right, manage your money, stay healthy, plan your child's education, learn about federal benefits and more.

So sharpen your pencil. Write for the free Consumer Information Catalog. And get reading worth writing for.



**Consumer Information Center
Department RW
Pueblo, Colorado 81009**

A public service of this publication and the Consumer Information Center of the U.S. General Services Administration.

The idea of *Fast Seek* is like that of *Fast Open*, but with the cluster numbers of files cached instead of directory entries.

entries by caching them in memory. The first parameter of the FASTOPEN command specifies the number of cache entries. The cached directory entries are maintained in a tree structure and are managed using an LRU scheme. The interfaces between the DOS kernel and Fast Open are listed below.

- *Lookup*. The DOS kernel always issues a lookup to Fast Open before reading the file-directory entry from disk. FASTOPEN results in one of three conditions: *found*, *partially found*, or *unfound*. For example, for the path of A\B\C\D, the found condition returns the directory entry of D; the partially found condition returns the directory entry of the subdirectory in the path—for example, A, B, or C; and the unfound condition implies that DOS needs to read disk sectors into system buffers and search for directory entries A, B, C, and then D.
- *Insert*. Inserts a file-directory entry in Fast Open—for example, when a file is opened.
- *Delete*. Deletes a file-directory entry from Fast Open and makes it free—for example, when a file is deleted or renamed.
- *Update*. Updates a file-directory entry in Fast Open—for example, when a file's attribute is changed.
- *Purge*. Purges all directory entries in Fast Open—for example, when the disk is formatted or the absolute sector write (INT 26H) function is issued.

The interactions between the DOS kernel and Fast Open are shown in figure 4. Figure 5 shows the test results performed on a PS/2 Model 60 by copying files from an N-level-deep subdirectory to another N-level-deep subdirectory for 10 iterations, where N is 5 or 10 and each subdirectory contains five 32K-byte files. A consistent performance gain is achieved with 20 Fast Open cache entries installed.

Fast Seek

The idea of Fast Seek is like that of Fast Open. Instead of caching the directory entries, the cluster numbers of the files are cached. In DOS, the file is composed of one or more clusters. A cluster is the basic disk-allocation unit, which contains one or more sectors (depending on the media format). From the user's point of view, a file is a string of bytes and all clusters are logically contiguous. That means a file starts from logical cluster 0, continues in 1, and so on. But a file may not be physically contiguous (e.g., logical cluster 0 might map to physical cluster 100, and logical cluster 1 might map to physical cluster 200).

DOS keeps the information about free disk space and file clusters in a block of disk sectors called the file allocation table (FAT). When a file is created, the physical cluster numbers of the file are chained and recorded by the FAT sectors. Before each read or write to the file, DOS calculates the current file

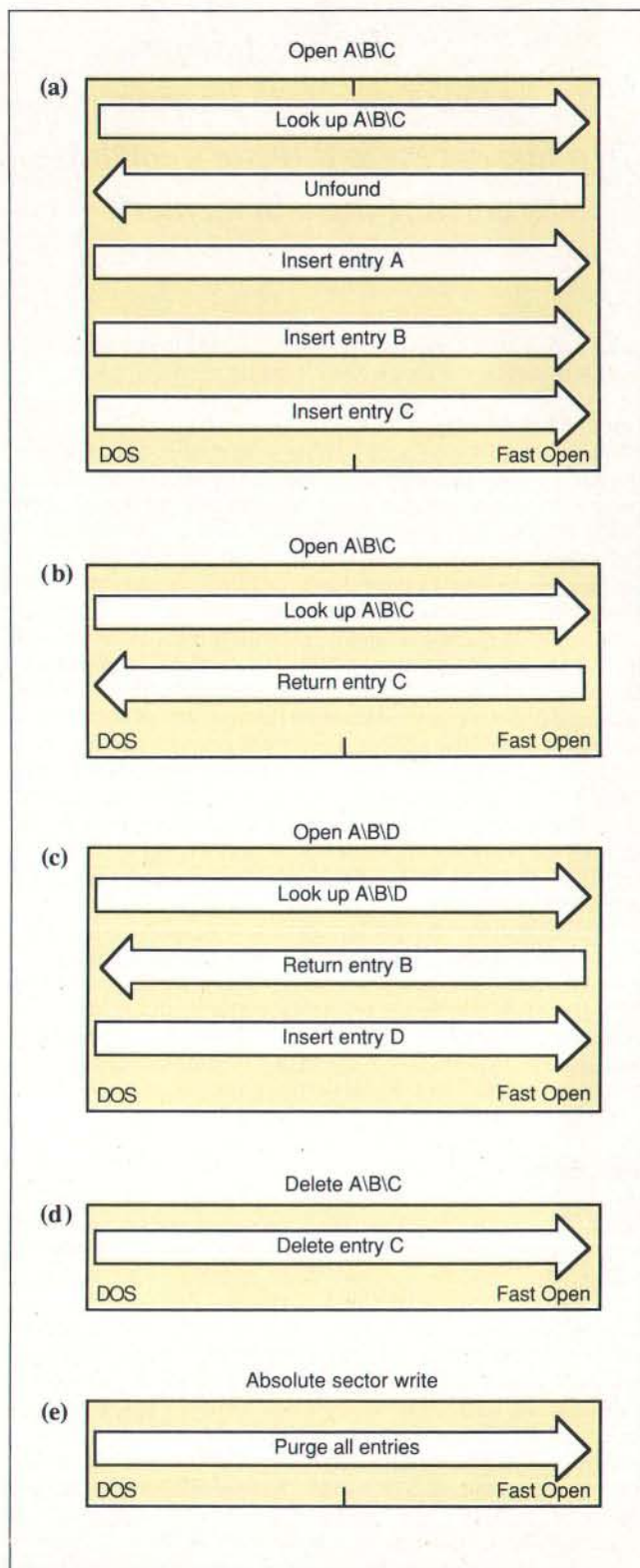

Figure 4: The interactions between the DOS kernel and Fast Open operations: (a) initial Lookup; (b) Lookup with complete table; (c) Lookup for a different filename; (d) deleting an entry from Fast Open table; (e) absolute sector writes, which invalidate all entries.

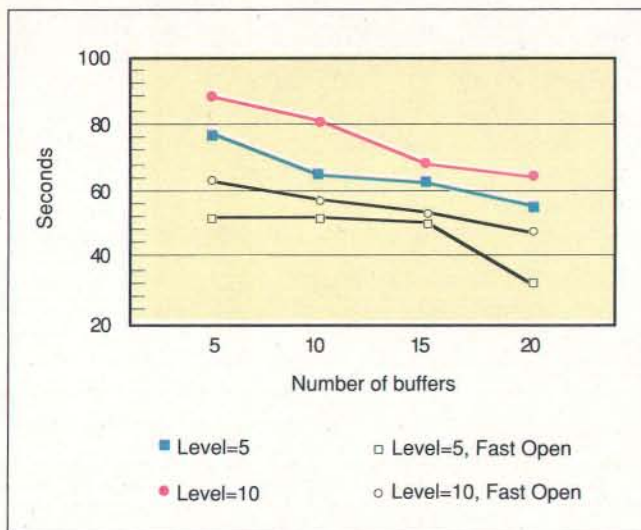

Figure 5: The performance improvements from using 20 Fast Open caches. The test copied files from an N-level-deep subdirectory to another N-level-deep subdirectory for 10 iterations, where N is 5 or 10 and each subdirectory contains five 32K-byte files.

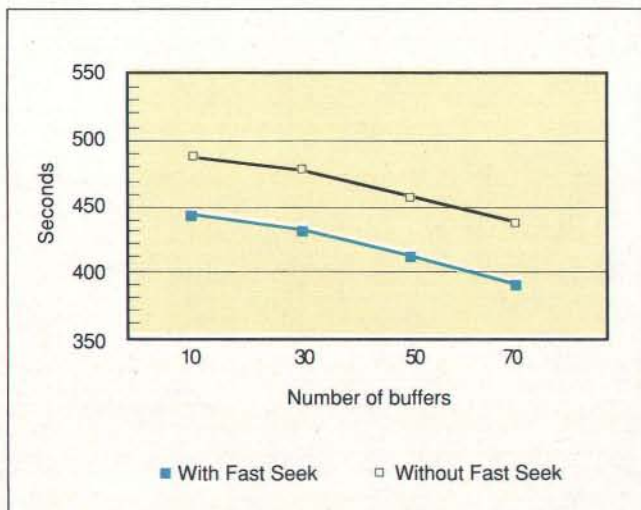

Figure 6: The performance improvements from using Fast Seek for random-sector reads and writes in the same test as for large buffers (12,800 random-sector reads and writes on a 256K-byte file).

position by tracing through the cluster chain.

Again, as in Fast Open, there are two possible causes for inefficient performance. First, each FAT sector may contain more than one file's cluster chain, and the chain may span more than one FAT sector. To trace through one file's cluster chain, DOS has to read FAT sectors into system buffers, wasting the buffer space and reducing the accuracy of the LRU scheme for system buffers. Second, it's inefficient to trace through the cluster chain if the physical clusters are contiguous and the destination cluster number can be easily computed by adding an offset to the starting cluster number. The intent of Fast Seek is to provide a very dynamic structure for the file's cluster numbers so that the search for the cluster chain is performed in

the most efficient way.

The second parameter of the FASTOPEN command specifies the number of cache entries for Fast Seek. Essentially, each cache entry contains the information on which file extents are defined as contiguous blocks of clusters. The extent is represented by the starting physical cluster number and the number of subsequent contiguous clusters. The more contiguous the file is, the fewer cache entries are used. If cache entries are exhausted by more than one opened file or randomly distributed file, Fast Seek uses an LRU scheme to reuse the cache entries.

The interfaces between the DOS kernel and Fast Seek are the following:

- **Open.** When a file is opened, Fast Seek creates a new file header (if it doesn't exist) or finds it from the close file list. The file header is made the most recently used.
- **Close.** When a file is closed, Fast Seek moves the file header and its cache entries to the close list.
- **Lookup.** The DOS kernel always issues a lookup to Fast Seek before reading the file's cluster chain from the disk. Fast Seek results in one of two conditions: *found* or *partially found*. The found condition returns the exact physical cluster number that needs to be positioned. The partially found condition returns the closest physical cluster number that Fast Seek has recorded. The worst case would be a return of the starting physical cluster number of the file.
- **Insert.** Inserts the file cluster information for Fast Seek—for instance, when a file is accessed for the first time after it has been opened.
- **Delete.** Frees a file header and its cache entries from Fast Seek—for example, when a file is deleted.
- **Truncate.** Truncates the file cluster information from Fast Seek—for instance, when the file size is truncated.
- **Purge.** Purges all cluster information from Fast Seek—for example, when the disk is formatted or the absolute sector write (INT 26H) function is issued.

Figure 6 presents the performance test figures of Fast Seek. The performance test case used was the same as the one shown for large buffers. The results indicate that Fast Seek consistently saves about 49 seconds when 10 cache entries are specified. To reach the same level of performance (443 seconds) without Fast Seek, 60 more buffers are needed—the equivalent of 30K bytes of memory compared to 5.8K bytes of Fast Seek memory. These results normally happen when there are sufficient cache entries to save all the file cluster information. The worst case happens when a file is huge, noncontiguous, and very scattered on the disk. In this event, if random I/O is frequently issued, the LRU scheme becomes overcommitted, and Fast Seek doesn't return useful information. One solution to this problem is to temporarily shut down Fast Seek until cache entries stop recycling.

Bringing DOS Up to Date

With the four new features described above, you can fine-tune your system with CONFIG.SYS commands to improve the performance of applications. You will find that the same programs, running on the same computer, will have faster file access. ■

Fetchi Chen is an operating-systems designer for IBM in Boca Raton, Florida. He specializes in performance optimization and is one of the architects of PC-DOS. He can be reached on BIX c/o "editors."

Canis lupus

#1 in a series of consumer habits

The timber wolf is equipped with

more than an iron will

to survive the rigors of nature.

It has a steel jaw with a bite of 1800

pounds per square inch.

Grazers they are not. Neither are

the readers of Byte magazine.

For they are a special breed

of advanced personal computing

experts whose hunger for

new product knowledge is not

readily satisfied by tidbits

of information. They crave content.

Meaty reviews. Technical

analysis. Something substantial to

sink their teeth into. Which

is what they get in every Byte. Some

publications may promise you

more readers than Byte's 435,000.

But none so voracious.





BYTE

The First of
the 25-MHz
Machines



Michael D. Smith '82

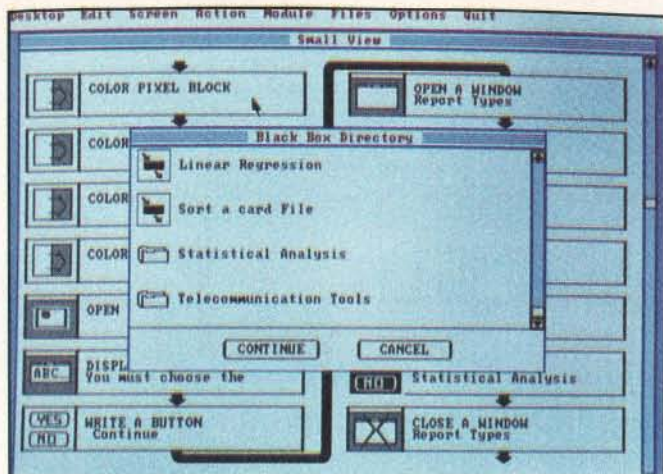

OOPS. Using sophisticated Object-Oriented Programming, Matrix Layout gives you the power to build complete applications faster than you thought possible. And that's just the beginning.

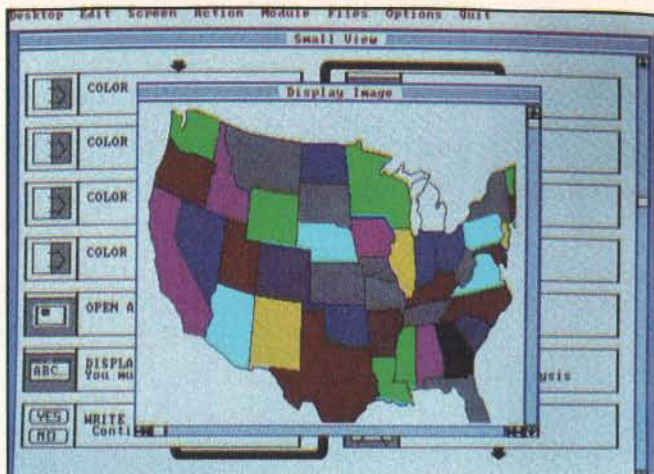

CASE. Layout's Computer Aided Software Engineering functions let you design programs using an intuitive flowchart model. Then, Layout can automatically turn your flowchart into source code or even an .EXE file.

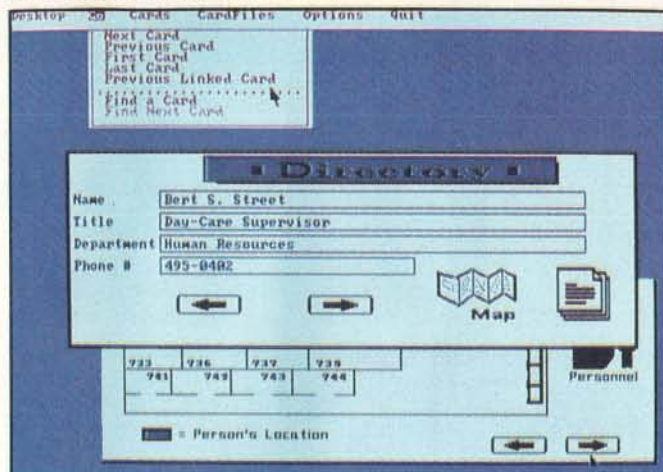

Hypertext. Layout puts all the features of Hypercard® on your PC and in your programs. Use Layout's graphical user interface to create documents with action links to related documents in any file. Or to create hyperlink applications.

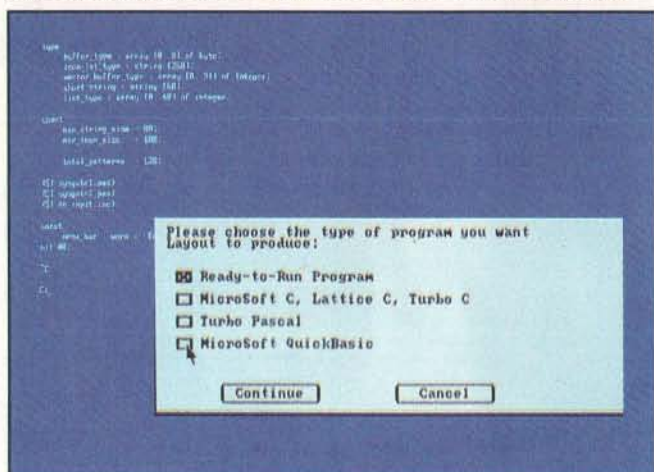

Plus, your favorite programming language(s). Using Layout's tools, you can cut your coding time up to 70 percent, and still produce ready-to-run programs in your choice of languages.

A Great Programming Tool Should Contain All Of The Above.

Presenting Matrix Layout, the first full software development system for the PC to promise you all the above. And deliver.

Sit down to Layout's intuitive user interface and in minutes you'll be using advanced OOPS (Object-Oriented Programming System) and CASE technology to build your program. Simply draw a flowchart indicating the windows, buttons, menus, text, and graphics you want.

A Cut Above Other Tools.

Layout also provides flowchart elements for Hypertext data base capabilities, math functions, variable management, conditional branching and looping. And, its open architecture allows you to build your own Black Box elements — to create exactly the program you want.

When your flowchart is ready, Layout uses

artificial intelligence technology to automatically turn it into code — Turbo Pascal, Turbo C, Microsoft C, QuickBasic or Lattice C. Or create a ready-to-run .EXE file right from within Layout.

It's so efficient, your programs will run incredibly fast, even on a standard 256K PC. Plus, they'll include Layout's automatic mouse support and device independence.

All The Above And More.

- *Matrix Helpmaker* helps you create context-sensitive help and complete on-line documentation for your programs.
- *Matrix Paint* offers a full set of graphics

tools, scanner support, and clip-art files to make your programs look professional.

- Finally, *Matrix Desktop* gives you a simple, visual way to organize files and disks.

For A Lot Below.

Layout delivers all the above for just \$149.95 — a lot below what you'd expect. Especially when you throw in free customer support, no copy protection, and a 30-day, money-back guarantee.

Video Tape Offer. Still not convinced? Call for a copy of our Matrix Layout VHS demonstration video at 1-800-533-5644 (just \$9.95 for shipping and handling, credited against your purchase). In Massachusetts, call (617) 567-0037.

Any way you look at it, Matrix Layout is the ultimate PC programmer's tool. And that's the bottom line.

MATRIX
LAYOUT

Matrix Software Technology Corporation • One Massachusetts Technology Center • Harborside Drive • Boston, MA 02128 • (617) 567-0037

Matrix Software/UK • Plymouth, England • 0752-796-363 • Matrix Software/Belgium • Geldenaaksebaan 476 • 3030 Leuven • 016202064
The following are registered and unregistered trademarks of the companies listed: Matrix Layout, Matrix Paint, Matrix Helpmaker, Matrix Desktop, Matrix Software Technology Corporation; Macintosh, Hypercard, Apple Computer, Inc.

AN END TO DUELING RULES

*A new program called Spot
helps you validate and verify rule bases*

Alex Lane

The Prolog programming language is one of several tools currently used for constructing expert systems. Expert systems are programs that use AI techniques to solve problems that usually require the attention of a human expert to resolve. However, as the popularity of expert-system tools grows and new applications for expert systems are found, problems have begun to arise.

I've written a Prolog program called Spot that examines Prolog rule bases for defects that might pop up to cause problems later on.

Dueling Rules

Things started out innocently enough one evening as I entered the following pair of rules in Prolog:

```
offspring(X,Y) :- father(Y,X).
father(alex,natalie).
```

Translated, the first rule states that X is the offspring of Y if Y is the father of X. The second rule (called a fact because there is no "if" operator present) states that alex is the father of natalie. If offspring/2 is queried with ?- offspring(A,B), the answer will be

```
A -> natalie
B -> alex
```

If you try to elicit another answer, Prolog's backtracking attempts will fail. With only the two rules shown, there is only one valid solution to the query.

I cleared the first two clauses (or so I thought) and entered the following rules:

```
offspring(X,Y) :- parent(Y,X).
parent(Y,X) :- mother(Y,X); father(Y,X).
father(alex,natalie).
```

This miniature rule base works much the same way as the first, illustrating how Prolog backward-chains through the predicate parent/2 to satisfy offspring/2. It is a common practice to denote Prolog predicates by name followed by a slash and the *arity* of the predicate. (The arity of a Prolog predicate refers to the number of arguments passed with the predicate call.) Thus, parent/2 denotes the predicate *parent*, which is called with two arguments.

My initial attempt to clear the Prolog environment failed, a victim of a typographical error. As a result, two errors were introduced in this five-rule miniature knowledge base. The first error, and the most apparent, is the presence of two identical father/2 rules. The existence of this duplicate is an error because a query to parent/2 will now obtain two answers while backtracking. (Even though the clauses are clones of one another, they are separate and, thus, fair game for the Prolog inference engine.)

The second (and maybe less obvious) error results in queries to offspring/2 generating more answers than expected. For each father/2 clause, offspring/2 gives two answers upon backtracking; one as a result of the first clause I entered, and another as a result of the clause that backward-chains. With two duplicate father/2 clauses, Prolog thus continues to backtrack until four answers are obtained.

So many problems in just five Prolog clauses! With a bit more care on my part, I could have avoided these problems, but these and more serious problems become increasingly likely as rule-oriented knowledge bases grow in size. In this respect, the perils that threaten rule bases are analogous to the pitfalls encountered in traditional software development efforts.

Parallels in Software and Knowledge Engineering

Someone once remarked that every program does something. By the same token, it can be said that every knowledge base proves something. The trick in both cases is to ensure that what the program does and what the knowledge base proves are what

continued

Listing 1: Definitions of Spot predicates that pick apart Prolog rules. dissect/2 takes a structure and returns a list. message_null_arity_predicates/2 helps normalize those lists.

```
dissect(H,Z) :-
    structure(H),
    H =.. D,
    !,
    dissect2(D,Z).

dissect1(H,Z) :-
    H =.. D,
    [H] \== D,
    !,
    dissect2(D,Z).
dissect1(H,H).

dissect2([],[]) :- !.
dissect2([H|T],Y) :-
    dissect1(H,Z0),
    dissect2(T,Z1),
    Y = [Z0|Z1],!.

message_null_arity_predicates(In,Out) :- % Message
    Null

Arity Predicates
    In = [Operator,Operand1,Operand2],
    current_op(_,_,Operator),
    deatomize(Operand1,NewOperand1),
    message_null_arity_predicates(Operand2,
        NewOperand2),
    Out = [Operator,NewOperand1,NewOperand2],!.
message_null_arity_predicates(In,In) :- !.

deatomize(In,[In]) :-
    not(list(In)),
    not(structure(In)),
    atomic(In),
    !.
deatomize(X,X).
```

Listing 2: Terms in AUX.ARI. These predicates help find errors and prevent excessive output from Spot. This file must be augmented if it is to be used with a test file other than TEST.OUT.

```
std_predicate(write).
std_predicate(read).
std_predicate(fopen).
std_predicate(read).
std_predicate('!EOF').
std_predicate(write).
std_predicate(nl).
std_predicate(assert).
std_predicate(fclose).
std_predicate(inc).
std_predicate(!).

irregular(male(X),female(X)).
irregular(father(X,Y),mother(X,Y)).
irregular(father(X,Y),father(Y,X)).
```

the original designer intended. Let's take a look at some ways in which rule-oriented knowledge bases can go wrong, and a prototype program, written in Prolog, designed to find such errors.

There are a number of parallels between traditional software engineers (e.g., those who program in C) and knowledge engineers (those whose tools go by names like KEE and Nexpert, and even Lisp and Prolog). Perhaps the most obvious is the problem of maintaining a life-size program or knowledge base. No matter how careful you may be, a defect will creep in somewhere along the way.

As I see it, a major difference between software and knowledge engineers is that the software engineers have developed a formidable array of tools, such as "lint," to help them maintain code. By contrast, knowledge engineers still maintain their knowledge bases "by hand."

Now, this practice might have been acceptable for the early knowledge bases that were put together with great deliberation, like programs on the first Altair microcomputers. However, expert-system programs that use such knowledge bases have ceased to be laboratory curiosities and today are making increasingly greater inroads in the real world.

Currently deployed examples include an expert system that schedules IBM's semiconductor manufacturing steps, and another system that assists in the authorization of credit at American Express. Just a few years ago, you could count the number of implemented expert systems on one hand; today, that effort would be a full-time occupation.

The proliferation of expert systems into the real world has also given rise to requirements that make effective maintenance of knowledge bases a very urgent topic in AI circles. Most important is the need to verify and validate the knowledge that goes into such systems. Verification can be thought of as the process that answers the question "Are we doing the job right?" while validation answers the question "Are we doing the right job?" Although verification and validation (often considered one subject, known as "V and V") are generally well understood in traditional software engineering circles, they are just starting to be addressed in the AI world.

Why Prolog?

Before an expert system can do its job, it must be supplied with knowledge. A knowledge engineer embeds such knowledge, obtained from a variety of sources including human experts, in a knowledge base in one of a number of different forms. The most common form is a set of IF...THEN rules, conceptually similar to IF...THEN statements in programming languages such as BASIC and C.

Among high-level languages, however, none uses the IF...THEN rule format quite like Prolog. Prolog programs may rightly be viewed as collections of rules. In addition, Prolog implementations that follow the so-called Edinburgh syntax have a powerful set of predicates that simplify manipulation of the various parts of rules. The more I thought about it, the more it became clear that the types of errors I was encountering in non-Prolog rule bases could be easily reproduced in Prolog, and that code could be developed to find those errors.

For these reasons, I decided to implement a knowledge-base-checking tool, or at least a prototype of one, in Prolog. By analogy with the lint utility used by C programmers, I christened my program Spot. I did most of the development effort on Spot in Arity/Prolog (version 4.0), although I also used Cogent Prolog to ensure I retained some semblance of portability. Turbo Prolog enthusiasts, however, may be disappointed to find that they cannot run Spot without heavy modification.

How Spot Works

Spot works in two ways: It parses the rule base and then checks it for errors. Since I wanted to concentrate on the error-checking feature, I decided to forego a bulletproof routine to allow input of the name of the file to check; the name is, therefore, embedded into the initialization predicate.

The program uses the `read/2` predicate to read rules from the input file. `Read/2` denotes the predicate `read`, which is called with two arguments. The `read/2` predicate has the advantage of immediately grabbing an entire rule and ignoring embedded comments. The program stores rules with a numerical tag that helps distinguish them and gives the program the option of using the `for/3` predicate (a passable implementation of a FOR loop in Prolog) to cycle through the rules.

The predicates `dissect/2`, `dissect1/2`, and `dissect2/2` work together to pick apart each rule (see listing 1). First, `dissect/2` checks to see that its first parameter is a structure (i.e., not an atom). The `univ` operator (`=..`) then transforms the parameter into a list. For example, the term `con(A,B,C) :- ant(D,E,F)` becomes `[-, con(A,B,C), ant(D,E,F)]`. The `dissect1/1` predicate then passes this list as an input parameter to the `dissect2/2` predicate. The `dissect2/2` predicate then recursively "walks" down the list and subjects each member to a similar procedure that calls `dissect1/2` for the head of the input list, and `dissect2/2` for the tail. In the end, the above example looks like

```
[:-, [con,A,B,C], [ant,D,E,F]].
```

One weakness of this routine is that it cannot distinguish between an atom and a name of a zero-arity predicate, so that a term like `con(A,B,C) :- ant dissects` into `[:-,[con,A,B,C],ant]`. For the sake of consistency, the predicate `ant` should be enclosed in list brackets in this example. On the other hand, a term like `open(X,Y,r)`, where `r` is an atom, dissects correctly into `[open,X,Y,r]`.

The program compensates for the weakness of the dissection predicates by calling the `message_null_arity_predicates/2` predicate. This code assumes that if the first element of the input parameter is an operator, then the remaining elements of the list should be processed; otherwise the input parameter is left unchanged. This predicate correctly changes `[:-,[con,A,B,C],ant]` into `[:-,[con,A,B,C],[ant]]` but leaves `[open,X,Y,r]` alone.

Another important step changes all rules of the form `X. to X :- true.` (which is what the first form implies), thus giving each rule a consequent and an antecedent part. Although traditional logic statements position antecedents to the left and the consequent to the right of the implication sign, as in this example:

Antecedent -> Consequent

the positioning is just the reverse in the well-written Prolog clause, like so:

Consequent :- Antecedent(s).

Once the rule base is completely normalized, the error checking can begin.

What Spot Does

There are a number of interesting and subtle ways that a knowledge base can go wrong, and let me say up front that Spot doesn't go after them all. The prototype presented here does,

however, attempt to illustrate some of the more common problems and ways in which you can detect them.

Perhaps the easiest check you can perform on a Prolog rule base is for duplication. As shown in the opening example, duplicate rules invite erratic program behavior. If Spot finds two rules that unify (which is a bit more subtle than simply saying they're identical), then a duplicate has been found.

The next test performed by Spot looks for what I call "irregularities." When the `find_irregular_rules` predicate is called, Prolog looks for instances of `irregular/2` in its

continued

Listing 3: Test file TEST.ARI. This is the file of Prolog terms to be checked by Spot.

```
test_predicate(X,Y) :-                                     % Rule 1
    demonstrate(five(levels(of(nesting(X,Y))))).

run :-                                                    % Rule 2
    write($Enter name of file to dissect: $),
    read(X),
    fopen(H,X,r), % note not much protection!
    run1(H).

run(H) :-                                                % Rule 3
    read(H,Term),
    Term \= '!EOF',
    write(Term),
    nl,
    assert(rule(Term)),
    run(H).

run(H) :-                                                % Rule 4
    fclose(H).

mother(alice,john) :- true.                             % Rule 5

grandparent(X,Y) :-                                     % Rule 6
    parent(X,Z),parent(Z,Y).

grandparent(X,Y) :-                                     % Rule 7
    parent(X,Z),parent(Z,Y),has(X,gray_hair).

female(galina).                                        % Rule 8
female(leslie).                                        % Rule 9

father(X,Y) :- parent(X,Y), male(X).                   % Rule 10
father(tom,jerry).                                    % Rule 11
father(william,edward).                               % Rule 12
father(alex,andrew).                                  % Rule 13
father(joe,jennifer).                                 % Rule 14
father(ken,karen).                                    % Rule 15
father(tom,jerry).                                    % Rule 16
father(A,B) :- male(A), parent(A,B).                  % Rule 17

male(alex).                                           % Rule 18
male(andrew).                                         % Rule 19
male(ken).                                             % Rule 20
male(leslie).                                         % Rule 21

parent(galina,natalie).                               % Rule 22
parent(alex,andrew).                                  % Rule 23
parent(ken,karen).                                    % Rule 24

parent(X,Y) :- father(X,Y).                           % Rule 25

for(X,X,X) :- !.                                       % Rule 26
for(X,Y,X).                                           % Rule 27
for(X,Y,Z) :- inc(X,X1),for(X1,Y,Z).                 % Rule 28
```

Orphans
are just errors waiting to happen
as long as they are present.

database. An example of an irregular relationship is:

```
irregular(male(X),female(X))
```

which simply notes that X cannot be both male and female. Currently, the only irregularities that Spot considers are those that involve contradictions, but there is certainly room for expansion in this direction. As my example shows, the user must separately compile these `irregular/2` clauses and then make them part of either the Spot source code or a file that is consulted in conjunction with Spot. In preparation for further error checking, Spot combs through the rule base and picks out all the predicates on the antecedent side of each rule.

Once the program finds the antecedents for each rule, Spot can perform additional error detection.

A less serious yet notable error in rule bases is the presence of what I call "orphan rules." These are rules that will never fire, because the consequent of the rule never appears as an anteced-

ent in any other rule. In some cases, these orphans are nothing more than utility predicates (included by the software developer) that have no direct bearing on the code. Most of the time, however, these orphans do nothing but take up space and are errors waiting to happen as long as they are present.

Using Prolog's powerful `findall/3` predicate, Spot finds such rules quickly. It's important to note that every Prolog program has at least one orphan, specifically the name of the predicate that you query to get the whole thing started.

Analogous to orphan rules are "unfireable rules." These are rules that will never fire because at least one of the consequents to the rule has no way of being satisfied. For example, the rule

```
A:- X, Y, Z.
```

will always fail if no clauses exist in the database for X, Y, or Z. I have found this error to be fairly common in working with rule bases, and to be one of the most difficult to trap without closely examining the rule base text. The program cannot differentiate between user-written predicates that are unfireable and standard predicates that, by definition, have no defining clauses in the rule base.

To remedy this weakness and cut down on the volume of Spot's output, I used the `std_predicate/1` clause, which checks to see whether a predicate is a standard predicate before Spot judges a rule to be unfireable. I combined and maintained the `std_predicate/1` and the `irregular/2` predicates in a separate file for ease of use (see listing 2).

continued

Give your software maximum protection
but eliminate customers' complaints

HASP-II™

Hardware for Software Protection

HASP-II is a hardware device that connects externally into the printer port of the IBM PC/XT/AT and PS/2 families.

Special electronic circuits form a unique code allowing only your customers to operate the protected software.

Your customer can create backup copies of his programs but these copies cannot be used on a "HASPlless" computer.

Implementation is easy. You won't need the source program in order to protect your software, and yet if you have the source, we offer you the option to check for the HASP-II from within the program at any time.

**We have sold tens of thousands of plugs
to dozens of satisfied customers worldwide**



For further information contact us at

ALADDIN
KNOWLEDGE
SYSTEMS LTD.

P.O.B.11141 Tel-Aviv 61110, Israel
Tlx.35770/1 COIN IL Ext. JBL
Tel. 972-3-226286, Fax. 972-3-243540

Buy with

Confidence

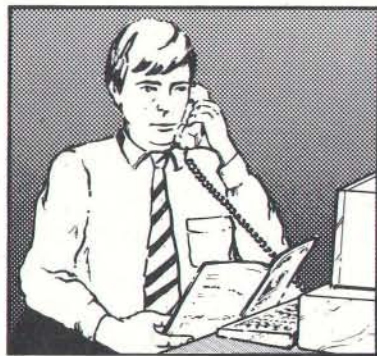

In an effort to make your telephone purchasing a more successful and pleasurable activity, The Microcomputer Marketing Council of the Direct Marketing Association, Inc. offers this advice, "A knowledgeable buyer will be a successful buyer." These are specific facts you should know about the prospective seller before placing an order:

Ask These Important Questions

- How long has the company been in business?
- Does the company offer technical assistance?
- Is there a service facility?
- Are manufacturer's warranties handled through the company?
- Does the seller have formal return and refund policies?
- Is there an additional charge for use of credit cards?
- Are credit card charges held until time of shipment?
- What are shipping costs for items ordered?

Reputable computer dealers will answer all these questions to your satisfaction. Don't settle for less when buying your computer hardware, software, peripherals and supplies.

Purchasing Guidelines

- State as completely and accurately as you can what merchandise you want including brand name, model number, catalog number.
- Establish that the item is in stock and confirm shipping date.
- Confirm that the price is as advertised.
- Obtain an order number and identification of the sales representative.
- Make a record of your order, noting exact price including shipping, date of order, promised shipping date and order number.

If you ever have a problem, remember to deal first with the seller. If you cannot resolve the problem, write to MAIL ORDER ACTION LINE, c/o DMA, 6 E. 43rd St., New York, NY 10017.

This message is brought to you by:

the MICROCOMPUTER
MARKETING COUNCIL
of the Direct Marketing
Association, Inc.
6 E. 43rd St.,
New York, NY 10017

MMC
MICROCOMPUTER
MARKETING COUNCIL
of the Direct Marketing Association, Inc.

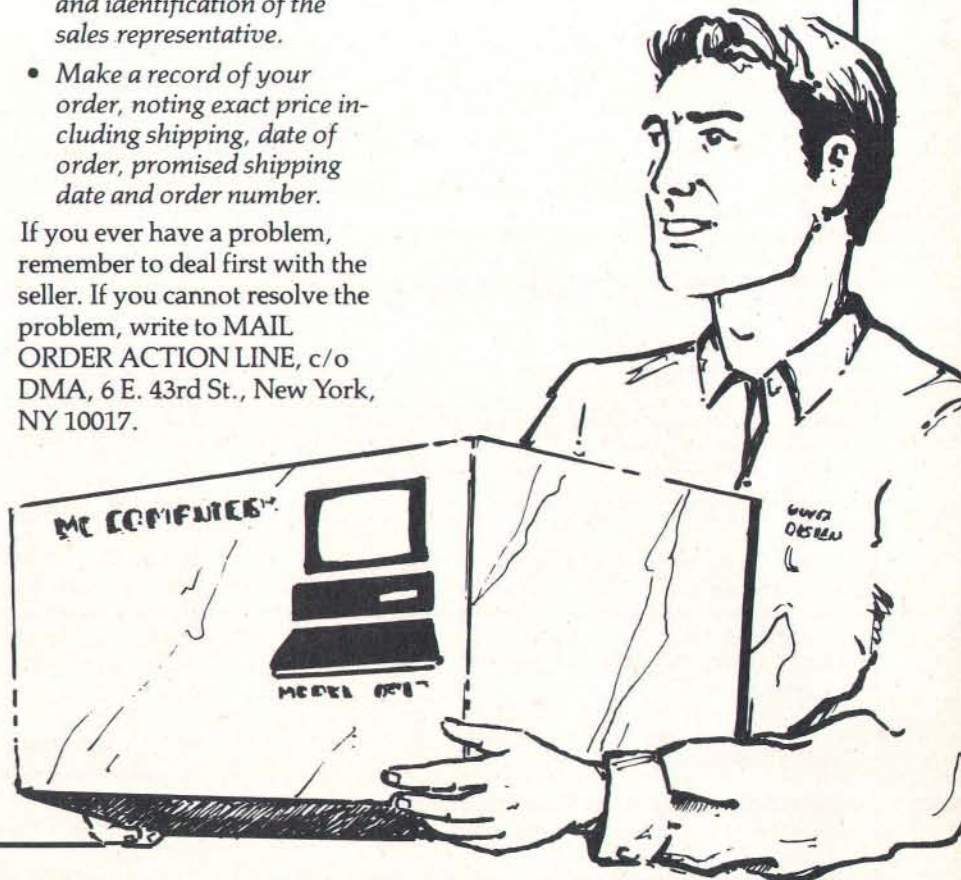

Finally, the last error that Spot tries to identify deals with *subsumption*. Simply stated, two rules subsume one another if they both have the same consequent and one rule's antecedents are a subset of the other rule's antecedents.

This relationship is, perhaps, better illustrated in the following example:

Listing 4: *The output file TEST.OUT. This output is produced by Spot after reading and checking the file TEST.ARI.*

```

Initializing...28 rules.
Transforming...normalizing....
  I/O, I/O, it's off to work we go!

DUPLICATIONS.....

RULES 16 and 11 have been found to be duplicate.
The rule reads: father(tom,jerry).

IRREGULARITIES.....

Rules 21 and 9 appear to be contradictory.
male(leslie) <--> female(leslie)

ORPHAN FACTS.....

Consequent predicate test_predicate in RULE 1 isn't
used as antecedent.
Consequent predicate run in RULE 4 isn't used as
antecedent.
Consequent predicate mother in RULE 5 isn't used as
antecedent.
Consequent predicate grandparent in RULE 6 isn't used
as antecedent.
Consequent predicate grandparent in RULE 7 isn't used
as antecedent.
Consequent predicate female in RULE 8 isn't used as
antecedent.
Consequent predicate female in RULE 9 isn't used as
antecedent.
Consequent predicate run in RULE 2 isn't used as
antecedent.
Consequent predicate run in RULE 3 isn't used as
antecedent.

UN-FIREABLE RULES.....

RULE 1 cannot fire because 'demonstrate' doesn't
appear as consequent.
RULE 1 cannot fire because 'five' doesn't appear as
consequent.
RULE 1 cannot fire because 'levels' doesn't appear as
consequent.
RULE 1 cannot fire because 'of' doesn't appear as
consequent.
RULE 1 cannot fire because 'nesting' doesn't appear as
consequent.
RULE 7 cannot fire because 'has' doesn't appear as
consequent.

SUBSUMED RULES.....

The antecedents of RULES 6 and 7 subsume one another.
The antecedents of RULES 10 and 17 subsume one
another.
```

```

grandparent(X, Y) :-
  parent(X,Z),parent(Z,Y).
grandparent(X, Y) :-
  parent(X,Z),parent(Z,Y),has(gray_hair,X)..
```

Notice that for the two rules shown, it is immaterial whether X has gray hair, as long as X is the parent of Z, and Z, in turn, is the parent of Y. This rule is sure to fire at least once, and erroneously twice if `has(gray_hair,X)` is true.

Running Spot

I cooked up a trial rule base that includes examples of all the problems Spot is designed to detect and, as mentioned before, embedded the name of the file in the `initialize_rule_base/0` predicate. In a few seconds, Spot processed the nearly 30 rules in the test case (see listing 3). I found it convenient to redirect the program output to disk from within Prolog by issuing the query

```
?- tell('test.out'),run,told.
```

This query opens the file TEST.OUT, runs the program, and then closes the file (see listing 4).

The Future

There is tremendous room for expanding the scope of this prototype. Spot's most obvious limitation is its ability to deal only with Prolog rules. Yet, despite this constraint, you could write extensions to allow for the modularization of a program among several Prolog source files and still keep Spot from identifying spurious errors (which would be along the lines of going to great efforts to keep lint from producing meaningless warnings).

There are a number of conceptual error-detection hurdles that the user must understand and overcome as well. For example, Spot does not yet detect the error that occurred with `offspring/2` at the beginning of the article. There, when Prolog proves that `parent/2` is true, the program effectively proves that `father/2` is true as well. This procedure results in what I call an indirect subsumption.

Other errors that you may run across include detection of infinite recursion, detection of synonyms and aliases, and comparison to a set of legal values.

Despite its limitations, Spot is still a useful program, primarily because of the handful of things it does, such as finding duplications, contradictions, and orphans, and the fact that it does things that need to be done and there are few tools around that perform these functions. With more tools like Spot, knowledge engineers will have greater control over the rule bases they create; eventually, the tools will provide a means to reliably verify and validate rule bases.

ACKNOWLEDGMENT

The inspiration to actually sit down, consolidate my notes, and write the code came from a tutorial session presented by R. A. Stachowitz and C. L. Chang at the Seventh National Conference on Artificial Intelligence, held in St. Paul, Minnesota, last year.

Editor's note: *Listings that accompany this article are available in a variety of formats. See page 5 for details.*

Alex Lane is a knowledge engineer with Technology Applications, Inc., in Jacksonville, Florida. He can be reached as "a.lane" on BIX, where he moderates the prolog conference.

MicroWay Means Numerics!

MicroWay is your best source for the software and hardware you need to get true 32 bit performance from your 386. These include 32-bit tools, such as NDP Fortran, C, and Pascal, and the 32-bit applications that were developed with them (see last paragraph). These products run in protected mode under Unix, Xenix, or Phar Lap extended MS-DOS.

Starting with release 1.4VM, NDP Fortran, C and Pascal not only access 4 gigabytes of memory, but run with Phar Lap's new VMM extension which provides 386 protected mode virtual memory. Now you can run a program with a 30 MB array on a 2 MB system simply by having 30 MB of space on your hard disk.

MicroWay also offers transputer based parallel processing boards and languages that run in an XT, AT, or 386. Each of the T800 RISC processors on these boards packs the power

Dr. Robert Atwell, leading defense scientist, calculates that NDP Fortran-386 is saving him \$12,000 per month in rentals of VAX hardware and software while doubling his productivity!

Fred Ziegler of AspenTech in Cambridge, Mass. reports, "I ported 900,000 lines of Fortran source in two weeks without a single problem!" AspenTech's Chemical Modeling System is in use on mainframes worldwide and is probably the largest application to ever run on an Intel processor.

Dr. Jerry Ginsberg of Georgia Tech reports, "My problems run a factor of six faster using NDP Fortran-386 on an mW1167 equipped 386/20 than they do on my MicroVAX II."

of a 20 MHz 386/1167. Our best selling board, the Quadputer2™, has four T800s and boasts 40 MIPS/6 megaflops of processor throughput.

MicroWay manufactures Weitek 1167 and 3167 coprocessor cards that run with the 80386. Both cards include an 80387 socket. The 1167 is 2 to 4 times faster than the 80387. The 3167 runs 30% faster than the 1167 in double precision. The key to achieving this speed increase is our NDP Fortran or C and the new 32-bit applications that offer Weitek support. Either processor provides a dramatic increase in throughput for graphics intensive applications. These include VersaCad and Hoops 3D graphics, ANVIL 5000 CAD/CAM, SRAC and Swanson Analysis finite element packages, Mathematica and a host of other packages that were recently ported to the 386 using our NDP Fortran and NDP C. Please call (508) 746-7341 for more information.

32-Bit Compilers and Tools

NDP Fortran-386™, NDP C-386™, and NDP Pascal-386™ compilers generate globally optimized, mainframe quality code. Each runs in 386 protected mode under Unix, Xenix or Phar Lap extended MS-DOS. The memory model employed uses 2 segments, each of which can be up to 4 gigabytes. They generate code for the 80287, 80387, mW3167 or mW1167 and include high speed EGA graphics extensions written in C that perform BASIC-like screen operations. NDP Fortran-386™ is a full implementation of FORTRAN-77 with Berkeley 4.2 and Fortran-66 extensions. NDP C-386™ is a full implementation of AT&T's PCC with MS and ANSI extensions. NDP Pascal-386™ is a full implementation of ANSI/IEEE Pascal, with extensions from C and Berkeley 4.2 Pascal. NDP Fortran/C/Pascal-386/DOS each \$595 NDP Fortran/C/Pascal-386/VM.....\$695 NDP Fortran/C/Pascal-386/UNIX.....\$795

Phar Lap 386/VMM extensions are supported by the VM releases of NDP Fortran, C, and Pascal, making it possible to compile and run programs as large as the free space on your hard disk.

Phar Lap Virtual Memory Manager...\$295
Phar Lap Development Tools.....\$495

NDP Windows™—NDP Windows includes 80 functions that let you create, store, and recall menus and windows. It works with NDP C-386 and drives all the popular graphics adapters..... Library: \$125, C Source: \$250

NDP Plot™—Calcomp compatible plot package that is callable from NDP Fortran. It includes drivers for popular plotters and printers. Works with CGA, MDA, EGA and VGA...\$325

NDP/FFT™—Includes 40 fast running, hand coded algorithms for single and double dimensioned FFTs which take advantage of the 32-bit addressing of the 386 or your hard disk. Callable from NDP Fortran with mW1167 and 80387 support.....\$250
387FFT for 16-bit compilers.....\$250

NDP to HALO '88 Graphics Interface — Enables you to call graphics routines in HALO '88 from NDP Fortran, C or Pascal.....\$100

Parallel Processing

Videoputer™—The highest performance graphics card on the market. Uses a T800 and TI 34010 in conjunction with a 130 MHz BrookTree DAC. Includes one MB of system RAM, one meg of video RAM and a library of graphics primitives. Runs standalone or in conjunction with a transputer network and drives 32 and 64 KHz analog monitors.....\$4995

Monoputer™—The world's most popular PC transputer development product now extends the memory available for developing transputer applications from 2 to 16 MB. The board features a DMA bus interface for fast I/O.

Monoputer with T414 (0 MB).....\$995
Monoputer with T800 (0 MB).....\$1495

Quadputer™—This board for the AT or 386 can be purchased with 2, 3 or 4 transputers and 1 or 4 MB of memory per transputer. Two or more Quadputers can be linked together to build networks of up to 100 or more transputers providing mainframe power.....from \$3495

Linkputer™—Uses four Inmos C004 programmable cross bar switches. It allows the user to dynamically change the topology of the processors in a network. Using this board, it is possible to get 100% linkage among eight Quadputers and design larger, custom topologies.....CALL

Transputer Compilers and Applications
These Parallel languages are designed for use with Monoputer2 and Quadputer2.

Logical Systems Parallel C.....\$595
3L Parallel C or 3L Parallel Fortran...\$895
COSMOS/M - Finite element analysis...CALL
ParaSoft: Parallel Environment.....\$500
Performance Monitor.....\$500
C Source Level Debugger \$500
T800/NAG™ (See NDP/NAG).....\$2750

387BASIC™—Our 16-bit MS compatible compiler introduces numeric register variables to produce the fastest running 80x87 code on the market.....\$249

NUMERICS HOTLINE
(508) 746-7341

386 Your AT

386/387 Turbo™AT—This board plugs into your 80286 socket, allowing your IBM AT to run 32-bit protected-mode code written for the 80386. Includes an 80387 socket. The most cost-effective AT upgrade!

386/387 Turbo AT/16MHz.....\$495
386/387 Turbo AT/25 MHz.....\$695

Weitek-Based Coprocessor Boards

mW1167™ and mW3167™ coprocessor boards are built at MicroWay using Weitek components. Each includes an 80387 socket.

Intel Coprocessors and RAM

mW1167-16.....\$895
mW1167-20.....\$1095
mW1167 Microchannel-16/20.....CALL
3167-20.....\$995
3167-25.....\$1295
3167-33.....\$1695
mW3167/80387 Board.....\$150

8087.....\$84 8087-2.....\$120
80287-8...\$195 80287-10.....\$220
80387-16...\$350 80387-16SX...\$310
80387-20...\$400 80387-25...\$500
80C287A (CMOS).....\$280
287Turbo-12 (for AT compatibles)....\$350
RAMpak™—one meg 32-bit memory module for Compaq 386 20/25.....\$495
RAMpak™—four meg.....\$1995
256K 80ns DRAM.....\$8.00
256K 100ns DRAM.....\$6.50
256K SIMMs 100ns.....\$99
1 meg SIMMs 100ns.....\$300
(All of our Intel coprocessors include 87Test.)

Multi-User Accelerators

MicroWay's AT8™ and AT16™ intelligent serial controllers run 8 to 16 terminals under Unix or Xenix without bogging down your AT, 80386 or PS/2 PC. AT8: \$895 AT16: \$1295

12 MHz PC Accelerators

FastCACHE-286 12 MHz.....\$299
SuperCACHE-286 12 MHz.....\$399
FastCACHE-286 9 MHz.....\$199

MicroWay

World Leader in PC Numerics

Corporate Headquarters: P.O. Box 79, Kingston, MA 02364 USA (508) 746-7341
32 High St., Kingston-Upon-Thames, U.K., 01-541-5466
USA FAX 508-746-4678 Germany 069-75-2023

Display this month's
BIX activities

J U N E

THURSDAY, 6/1, 8:30 PM EST. "The Philosophy of Ada"

Ada thinkers Randy Brukardt, Dan Stock, and Geoff Gilpin lead a CBix discussion on the philosophy of Ada and software engineering with Ada, and answer questions about R.R. Software's JANUS/Ada line of products. (join janus.ada/cbix)

TUESDAY, 6/6, 9 PM EST. "It's That Time of the Month, Again"

It's the first Tuesday of June, and BIX's IBM PC conference members meet for their monthly CBix session. (join ibm.pc)

THURSDAY, 6/8, 9 PM EST. "Computer Viruses, Past and Present"

"Doctor" Ross Greenberg, creator of the anti-virus program *Flu Shot*, outlines the history of computer viruses and prescribes the latest preventive medicine. Co-hosted by Howard Shubs, moderator of the BIX Security conference. (join security/cbix)

SUNDAY, 6/11, 9 PM EST. "32-Bit Quick Draw—'The Big Picture'"

Ponder the future of 32-bit Quick Draw, with Larry Loeb, BIX Mac Exchange Editor, and invited guests. (join cbix)

TUESDAY, 6/20, 9 PM EST. "Security in a Networked Environment"

What common-sense security measures can network administrators take? Find out from Dr. Bob Harbort, chairman of the Computer Science Department at Southern Tech., and Bob Brown, director of Information Systems for the Georgia Medical Care Foundation. (join data.center/cbix)

All-Month Conferences

The Cold Fusion Discovery is the hot topic of BIX's tojerry conference, hosted by Jerry Pournelle. One conference member—a physics professor at a large, midwestern university—announced that much information appeared on BIX before it reached the physicists' grapevine. (join tojerry/journal)

You-saw-it-here-first Department—Not only did *BYTE*'s Mac SE/30 coverage scoop its print competition in February, full details of it appeared on BIX just moments after Apple's announcement. BIX readers were enjoying an in-depth report on Sun Microsystem's SPARCStation 1 just hours after it made its debut. Look for more scoops this month as the Microbytes staff reports from PCEXpo in New York. (join microbytes)

In-Depth Conference Topics

BYTE's In-Depth section this month is on Computer Security, an issue that's widely discussed on BIX, as well. You'll find it in such conferences as Security, Unix, Software.Eng (software engineering), BBS, and in many individual computer conferences. In addition to these important discussions, here is a partial list of security-related files from which you may wish to download:

Amiga Listings Area

avbb55.arc—Antivirus bootblock version 5.5. Finds and kills SCA and ByteBandit virus in memory.
bootback.arc—Boot Block backup program with executable and source in Amiga/Programs. For virus

protection.

sb221.arc—SafeBoot2.21 fixes bug found when used with WB1.3. Saves and restores bootblocks. Useful after virus has altered bootblock.

IBM PC Listings Area

flu4.txt—A warning regarding a trojan called flu4txt.com.

fsp_152.arc—Ross Greenberg's Flu Shot + , V1.52, anti-Virus/trojan protection program. Protects your system against viruses, trojans, and dumb mistakes.

Macintosh Listings Area

ferret11.sit—Larry Nedry's virus seeker and killer.

gatekeep11.sit—Gatekeeper provides anti-viral monitoring of your system.

repair15.sit—Repairs and removes the nVIR virus from application and system files.

rwatcher.sit—Written for those non-MPW programmers seeking some virus protection, but not willing to use Vaccine.

vaccinat.bin—Checks for nVIR virus and kills it.

Utilities Listings Area

bombfree.arc—A group of programs to help protect your data from worm and trojan horse software.

chk4bomb.arc—Checks for trojan horse programs.

chkfat.arc—Checks the File Allocation Tables (FAT) on disk match.

unvirus.arc—Test for several types of virus on your disk.

Finally. An on-line service that doesn't nickel and dime you.

It's BIX's flat-fee service.

BIX is short for BYTE Information Exchange. The on-line information service that's yours for an unheard-of flat fee of just \$39 for three months* — an amount you could easily blow in just two to four hours with an hourly rate, on-line service. (Not to mention the fact that you'd be nickel-and-dimed for its monthly minimums.)

And here's another distinction: BIX is strictly for microcomputer pros; it contains no "fluff." As a subscriber, here's what you've got coming to you:

- All the information and ideas exchanged in more than 150 microcomputer-related conferences — a give-and-take in which you can participate.

- Microbytes Daily* — up-to-the-minute industry news and new product information.
- Plus support from hardware vendors and software publishers, access to extensive software libraries, and the use of our electronic mail service — which allows binary attachments.

Subscribe to BIX right now — using your computer and modem.

Set your telecommunications program for full duplex, 8 bits, no parity, 1 stop bit, or 7 bits, even parity, 1 stop bit. Now dial BIX at 617-861-9767, hit the return key, and respond as follows:

Prompt:

login (enter "bix"):
Name?

You Enter

bix
bix.flatfee

You can charge your BIX subscription to major credit cards, or have it billed to your company. You may also purchase

unlimited off-peak access via Tymnet for just \$15 per month, or \$2 per off-peak hour.

For additional information, including your local Tymnet access number, call 800-227-2983 (in New Hampshire 603-924-7681).

**Based on a \$156 annual fee, billed quarterly — a subscription which you may cancel at any time without future quarterly charges. If you prefer, you may subscribe for a 3-month trial at just \$59.*

BIX

One Phoenix Mill Lane
Peterborough, NH 03458
800-227-2983 • In NH 603-924-7681

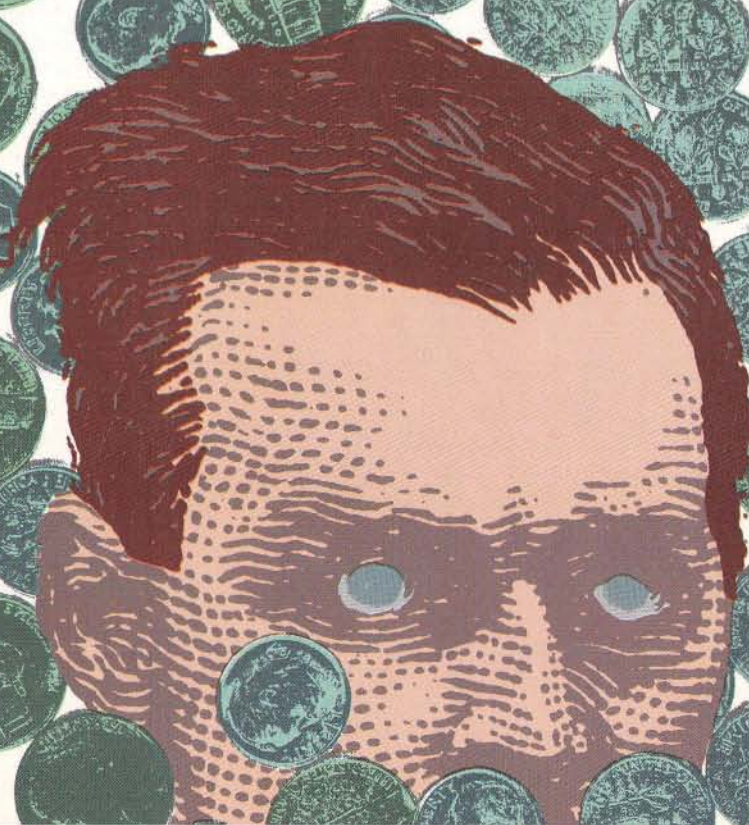

BYTE Subscriber Services Available

Your BYTE subscription brings you a complete diet of the latest in microcomputer technology every 30 days. The kind of broad-based objective coverage you've read in this issue. To ensure that you receive the best possible service during the term of your subscription, we have listed below a wealth of services, available to you as a BYTE subscriber.

BONUSES

- ✓ **Annual Separate Issues:** In addition to BYTE's 12 monthly issues, subscribers also receive our annual IBM PC issue free of charge, as well as any other annual issues BYTE may produce.
- ✓ **Reader Service:** For information on products advertised in BYTE, circle the numbers on the Reader Service Card enclosed in each issue that correspond to the numbers for the advertisers you select. Drop in the mail and we'll get your inquiries to the advertisers.
- ✓ **Subscription Service:** If you have a problem with, or a question about your subscription, you may contact us at the following addresses.

Europe:

BYTE Subscriptions
McGraw-Hill House
Maidenhead, Berkshire
England SL6 2QL

Outside Europe:

BYTE Customer Service
Department
Box 6821
Hancock, NH 03449 U.S.A.



Mail us the details along with the name, address and postal codes of the subscription. If the problem involves a payment, please include a copy of the credit card statement or front and back of your cancelled check. For information regarding back issues and editorial indices, write to the following address:

BYTE Customer Service
Department
Box 328
Hancock, NH 03449 U.S.A.

PAID SERVICES

- ✓ **BIX:** BYTE's Information Exchange puts you on-line 24 hours a day with your peers via computer conferencing and electronic mail. All you need is a microcomputer, a modem and a password. See the BIX ad (refer to Index for page) in this issue of BYTE for cost information on foreign registration and usage.
- ✓ **Program Listings:** Listings of programs that accompany BYTE articles are now available on BIX, on disks or in quarterly printed supplements (see reply cards in this issue for cost information).
- ✓ **Microform:** BYTE is available in microform from University Microfilm International in the U.S. and Europe. See Contents page for cost information.

DISCOUNTS

- ✓ **Group discounts** available for one-year subscriptions. For details write to the following address:

BYTE Group Subscriptions
P.O. Box 555
Hightstown, NJ 08520 U.S.A.

Be on the leading edge of micro technology. Subscribe to BYTE magazine and in addition benefit from all the aforementioned services. Complete and mail in a subscription card from the adjacent page.



Order your BYTE subscription with one of the convenient order cards in this issue or through a McGraw-Hill representative or magazine agency listed below:

McGraw-Hill Representatives:

France:
McGraw-Hill
18 Rue Des Cordonniers
78600 Maisons Lafite
1-39-62-57-79

Italy:
McGraw-Hill/Ceti
Lungo Po Antonelli 205
10153 Torino
11-8999023

Netherlands:
McGraw-Hill Benelux
Waalwijk 8
5327 AC Hurwenen
Netherlands
04182-1553

Scandinavia:
McGraw-Hill
Holm Marketing
Granstuevej 13
DK-2840 Holte
Denmark
2-422-806

Spain:
McGraw-Hill De Espana
Santa Beatriz 4
28038 Madrid
1-433-8777

Turkey:
McGraw-Hill
Halitaga Kad Eksioglu Ishani
Kad 4 No 101 Kadikoy
Istanbul
11-337-8145

United Kingdom:
Circulation Field Sales
McGraw-Hill
McGraw-Hill House
Maidenhead, Berkshire SL6 2QL
England
0628-23431

Austria/Switzerland/West Germany:
McGraw-Hill
Postfach 40 02 69
D-8000 Munchen 40
West Germany
89-525847

Agencies:

Austria:
Minerva
Postfach 367
A-1001 Vienna

Belgium:
Office International Periodiques
Avenue Louise 485
B-1050 Brussels

Denmark:
Harck & Gjellerup Booksellers
G.E.C. Gad Norreport
31-33 Fiolstraede
DK-1171 Copenhagen K

United Kingdom:
Blackwells Periodicals
PO Box 40
Hyde Bridge Street
Oxford OX1 2EU

Finland:
Akateeminen Kirjakauppa
PO Box 128
SF-00101 Helsinki 10

France:
Dawson France
Rue De La Prairie
91121 Palaiseau Cedex

Greece:
A. Atzemiam & Co
9 Amerikis Street
Athens 10672

Italy:
D.E.A.
28 Via Lima
00198 Rome

Netherlands:
Faxon Europe
2 Voorburgwal 60
Box 197
1012 SC Amsterdam

Norway:
Narvesen As Subscriptions
Boks 6125
Etterstad, Oslo 6

Portugal:
Fernando Machado & Co
15 Rua Das Carmelitas
4000 Porto

Spain:
Diaz De Santos Sa
Liberia Cientifico Tecnica
Calle De Lagasca 95/PO Box 6.050
Madrid 6

Sweden:
Esselte Tidskriftscentralen
PO Box 45150
S-10430 Stockholm

Switzerland:
Hans Huber
Langgassstrasse 76 & Marktgasse 9
3000 Bern 9

Turkey:
Caglayan Kitabevi
Beyoglu Takaoluyan Ust Pasaj
7-8-9-21 Istanbul

West Germany:
Kunst & Wissen
Willhelmstrasse 4
Postfach 46
D-7000 Stuttgart 1

Yugoslavia:
Cankarjeva Založba
Postni Predaj 201
61001 Ljubljana



THE ULTIMATE UPGRADE

The BYTE Lab turned a standard IBM PC AT into a personal workstation—but was it worth it?

Stanford Diehl

Remember the days when you had to assemble almost every product you bought? You would grit your teeth, pull your hair, grunt and curse and lament, but once that bicycle or stereo was built, you could step back and savor a true sense of accomplishment. Computers were like that, too. You had to partition drives and configure ports and set up the system. Now, it seems, you just turn them on and watch them go. But if you've got patience and plenty of hair, you can still do it yourself.

In that spirit, the BYTE Lab staff set out to create a high-performance, multitasking workstation from a standard IBM PC AT. Keeping a sharp eye on price, we customized a system, component by component, and evaluated the results. Then we took a step back to decide whether that special sense of accomplishment was worth the cost, the time, and the headaches.

Plugging in the Power

Our first inclination was to start from scratch with a new 80386 motherboard, complete with 32-bit slots and high-speed memory. Somehow, though, that didn't seem fair. After all, we would end up with only that stark beige case to remind us of our roots. So, instead we went with an 80386 enhancement board. We solicited two different

products, the Intel Inboard 386 and the AOX Master 386, and tested them both for performance, ease of installation, and compatibility (see photos 1 and 2).

We started by installing the Inboard. This, it turns out, was a mistake. We have since discovered that you should install your hard disk drive and peripherals first. Installation software for both of the enhancement boards evaluates your system configuration to determine the optimal setup parameters. So we set up our Inboard for the standard AT configuration, not for the souped-up system we ended up with.

Unfortunately, it is much harder to go back and change the enhancement board settings to enable new components. For one thing, you have to run the setup program before installing the board. Note, however, that you can modify the settings yourself with a little extra effort.

Intel offers two versions of the Inboard 386, one without memory for \$1395 and one with a megabyte of 32-bit, 120-nanosecond RAM for \$1995. Get the additional memory. Without it, your 32-bit processor will have to access 16-bit memory from the system bus. According to our benchmarks, memory fetches will be slower than they were without the 80386. You can also add an additional 1 megabyte (\$795) or 2 megabytes (\$1495) of 32-bit memory

continued



Photo 1: The Intel Inboard 386 provided our souped-up AT with a megabyte of 32-bit, 120-nanosecond RAM for \$1995.

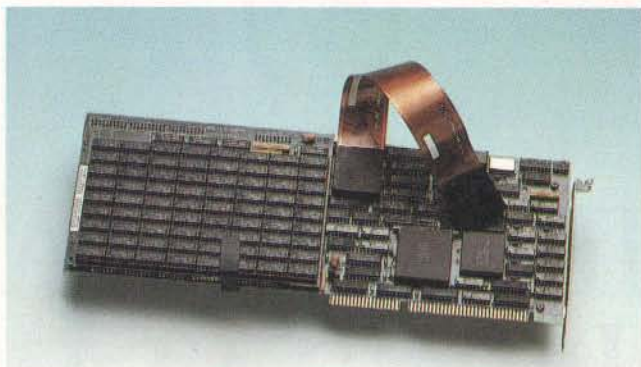

with an Inboard piggyback card. The card snaps onto the Inboard 386, allowing the processor to directly access the additional fast memory. At this writing, you are limited to 3 megabytes of 32-bit RAM with the Intel card. The Inboard will support other memory cards, such as the AST RAMpage Plus or the Intel Above Board 286, but you're back to the slower, 16-bit variety.

Intel's HARDSET program prompts you for various system parameters before determining the best way to set the Inboard's two banks of DIP switches. You then flip the switches, attach the piggyback card, crack the system cover, and remove both the 80286 and the 80287. If you have a 6-MHz AT, you'll also have to replace the crystal. A \$200 installation kit provides all the necessary tools, along with an 80287 plug, the Inboard cable, and documentation.

Both boards slide into one 16-bit slot, leaving room for an 8-bit card alongside the piggyback card. A cable runs from the 80286 socket to the Inboard. We also set a jumper to disable 256K bytes of our motherboard's 512K bytes of conventional memory. This lets you swap the system's slow conventional memory with the Inboard's 32-bit RAM. You end up not only with faster memory, but also with the full 640K-byte complement. The Inboard also provides zero-wait-state memory caching for all installed memory, including any 16-bit RAM. Inboard software utilities enable expanded memory, speed selection, and hard disk caching.

The Best of Both Worlds

For those who are skittish about making the 80386 plunge, AOX offers some solace by keeping your familiar 80286 snugly

Photo 2: You can easily install the AOX Master 386 enhancement board. Two configurations are available—a 16-MHz model (\$1595) and a 20-MHz model (\$1895).

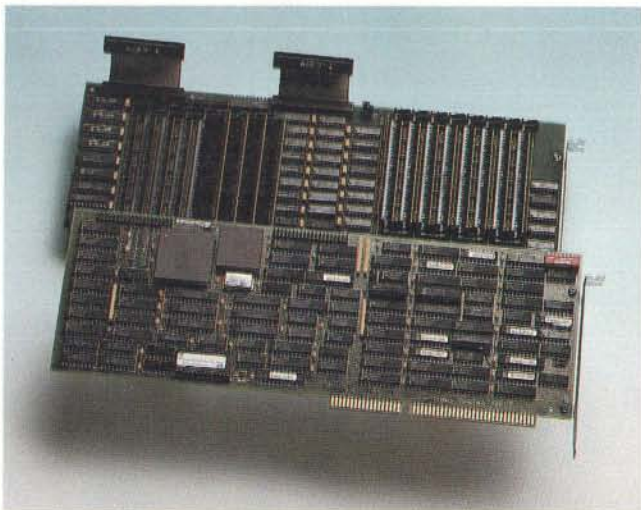

plugged in its slot. By simply loading a device driver, you can then hot-key between the two processors. Even when the 80386 takes precedence, the 80286 does not lie dormant. It acts as an intelligent controller, busily polling interrupts and passing control to its more powerful cousin. This makes the installation of the AOX board much easier than that of the Inboard.

And the advantages don't stop there. AOX offers not

only a 16-MHz board (\$1595) but a 20-MHz model as well (\$1895). And although the optional memory board takes up a full 16-bit slot, it also provides up to 15 megabytes of directly accessible 32-bit RAM. No need to resort to slow memory here.

The AOX Master memory board (\$700 plus \$605 per megabyte of RAM) slides into a slot adjacent to the Master 386. A pair of short cables provides a direct 32-bit path to the processor, and a bank of DIP switches controls caching, wait states, direct-memory-access channels, ROM addresses, and swapping of slow system memory with 32-bit RAM. You can cache all your memory, the ROM BIOS, and video ROM. The video cache significantly improved the system's performance on our suite of video benchmarks.

The 20-MHz AOX board scored better than the 16-MHz Inboard on our CPU index, even though the Inboard negotiated string moves faster. Both boards more than doubled the performance of the AT. Floating-point operations ran over five times faster. Again, the Master 386 performed slightly better than the Inboard, posting a 5.40 floating-point index to the Inboard's 4.71.

A Juggling Act

Oh, the limitations of DOS. Both cards do their best to deal with DOS, but problems crop up, especially when juggling memory. Eventually, when we install our multitasking operating system, we won't have to worry about memory allocation. Under Unix, we would simply make all memory extended and let the operating system handle it. Even OS/2 would avert the 640K-byte barrier. Still, the memory-allocation problems under DOS expose the shortcomings of plugging an 80386 card into a 16-bit bus versus running 32-bit system memory on a true 80386 machine.

Both enhancement boards allow you to switch slow conventional memory with on-board 32-bit RAM. Intel does it with 80386 control software while AOX does it in ROM. The 16-bit RAM cards provide expanded memory (between 640K bytes and 1 megabyte). The remaining 32-bit memory is mapped as extended memory (beyond 1 megabyte).

DOS application programs

continued

The Cool Machine Cometh



OKIDATA introduces a line of PC modems that run so cool they're guaranteed for 5 years.

Our new 1200, 2400 and 2400 *Plus* PC modems are built around a very simple fact: the cooler they run, the longer they last.

That's important in any modem, and it's vital in the case of an internal board. That's why we engineered a special chip that does the work of three ordinary chips. It also generates less heat—and consumes 50% less power—than the leading brand. Which is why we back our modems twice as long as they do.

But reliability on the inside comes as no surprise when the OKIDATA name is on the outside.

We have over a century of experience in telecommunications all over the world. And you'll see it in everything we make, from tank-tough printers to award-winning PC modems to a full line of high-speed modems.

To see our new "cool machines" in person, visit your OKIDATA dealer. Or call 1-800-OKIDATA for the name of the dealer nearest you.

Circle 201 on Reader Service Card

PC DIGEST

... gave five stars to our 1200 bps modem and top-rated our 2400 bps modem.

PC WORLD

... gave our 2400 their coveted "Best Buy" title.

Registered Trademarks: OKIDATA, Oki America, Inc.,
Marque déposée de Oki America, Inc.
Trademarks: PC Digest, National Software Testing
Laboratories, Inc.; PC World, PC World Commu-
nications, Inc.

OKIDATA[®]
an OKI AMERICA company

We put business on paper.

Photo 3: We found that the Columbia SCSI system, which came complete with an 84-megabyte Quantum hard disk and a Western Digital 7000-FASST controller, is best installed before the enhancement board.

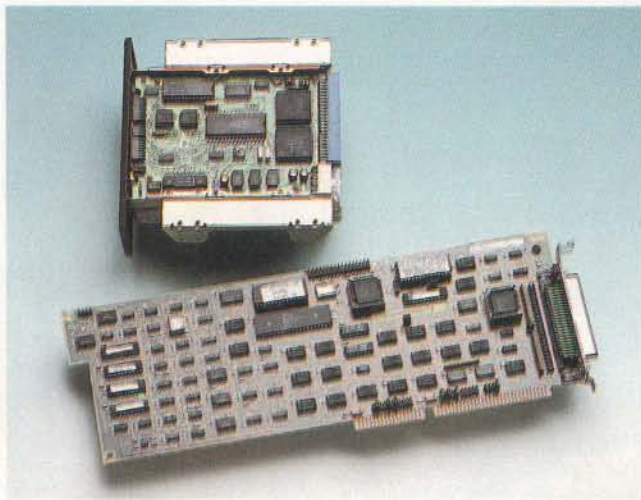

cannot directly use extended memory, although those programs conforming to the LIM/EMS can use expanded memory. Included Inboard utilities allow you to swap 16-bit expanded memory with 32-bit extended memory, thereby boosting the performance of programs that conform to LIM/EMS. Memory management software such as Quarterdeck's QEMM will similarly juggle the AOX memory.

But all this memory swapping invites trouble. While the 80386 chip is executing in virtual mode under 80386 control software, no other 80386 control software can access it. The Inboard would not run our 80386-specific benchmarks (doubleword-wide string moves) for just this reason. Memory swapping will also confuse a disk controller that reserves high memory to load its BIOS. Sometimes you simply can't swap. And if you end up using the motherboard RAM for conventional memory, the 80386 chip must take control of the AT bus to fetch 16-bit memory, slowing your system to a crawl. As much as your AT would like to run with the big boys, it can't quite break free of the 16-bit bottleneck.

The Hard Disk Dilemma

Choosing a hard disk drive becomes a question of interfaces. And again, the cost-versus-performance equation rears up. If you stay with the ST-506 interface, you can retain the services of your standard AT disk controller and end up with high-capacity disk storage at a bargain price. You are, however, saddled with a sluggish controller—but it's still the simplest solution. We found that out by hitching a Priam 130-megabyte hard disk drive (\$2385) to our existing WD1003-WA2 controller; it was quick and painless.

Another alternative is to go with ESDI. We selected the AT 90 drive and ESDI controller from CORE International. At

Photo 4: The NEC MVA 1024 graphics adapter (\$1499) supported the maximum resolution of our new monitor, the NEC MultiSync XL. The optional 384K bytes of video RAM cost \$300 but enabled us to use a 256-color palette.

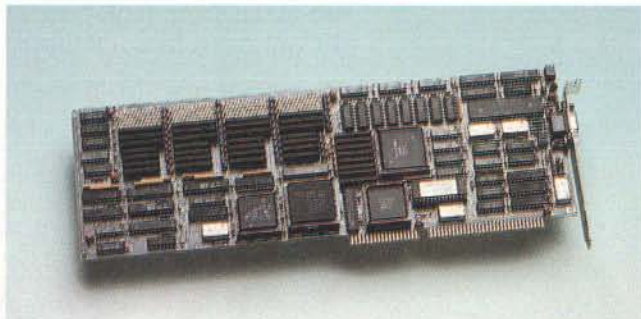

first, we had some problem with the controller's BIOS, but an included device driver remapped the BIOS to low memory. The entire package (\$1916 for the drive and \$476 for the controller) costs roughly the same as the Priam disk alone, but the CORE drive contains only 90 megabytes of storage space. If you really want to soup up your disk drive, you can go with a high-end ESDI controller like the PM3011 from Distributed Processing Technology (\$1150 with half a megabyte of on-board cache) or the Powerstor caching ESDI disk controller from Consensus

(\$1045 with half a megabyte of RAM). Each of these controllers is specifically designed for the Unix or Xenix operating system.

As the interface gets fancier, so too does the installation. The Columbia SCSI system is shipped with an 84-megabyte Quantum hard disk and the Western Digital 7000-FASST controller (\$1645 for the package). (See photo 3.) The first few times we tried to install this drive, the boot-up routine would drop us into BASIC—this was evidently another problem with ROM mapping. Finally, we removed the enhancement board, installed the drive on the standard AT, and then reinstalled the 80386 card. It turned out that the drive installation was fast and easy. Again, your best bet would be to install the disk drive and peripherals first and then plug in the enhancement board.

In any case, the SCSI drive returned the best disk benchmarks and earned a place on our workstation. The drive has an average access time of 19 milliseconds, a 64K-byte program-cache, 1-to-1 interleave, and an integrated SCSI controller.

High-Resolution Video

No workstation worth its salt is without high-resolution graphics. As we showed in the March Product Focus on large-screen monitors, the NEC MultiSync XL sets the standard for flexibility and ease of use. It offers a 19-inch screen and 1024- by 768-pixel resolution and currently sells for \$3499. The XL can plug into a wide variety of graphics adapters. We went with the NEC MVA 1024 adapter (\$1499). Based on the Texas Instruments TMS 34010, the MVA 1024 supports the XL's maximum resolution, and an optional 384K bytes of video RAM (\$300) provides a 256-color palette (see photo 4).

Western Digital Imaging has introduced a high-end graphics coprocessor card for CAD applications. The card, compatible with the MultiSync XL, packs 2 megabytes of video memory and displays 256 colors at 1024- by 768-pixel resolution. The Verticom HX-256/AT sells for \$3495. The card was not available for this evaluation.

If you can accept a lower-resolution graphics standard,

continued

Ask The Doctor

Your Most Important Questions

About PC Data Security.



Escalating instances of PC data theft and misuse affecting both government and industry have shown the need for an effective yet easy-to-use data security product. U.S. Public law 100-235 now mandates that government agencies protect sensitive data files.

In response, Dr. Alan K. Jennings, Ph.D., inventor and co-founder of Rainbow Technologies, has designed the DataSentry™, an external hardware key that provides data file security without the problems associated with internal hardware and software-based protection.

In this first of a series of informational bulletins, Dr. Jennings answers some of the more frequently asked questions on PC data security and the DataSentry system from Rainbow Technologies.

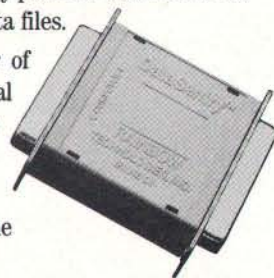

DataSentry

- Completely user-installable
- Pocket-sized external device
- Menu-driven, user-friendly interface
- Single- or multi-user security system
- Audit trail, log-on identifiers and automatic encryption/decryption of entire directories
- Secures data transmitted by modems
- Prevents recovery of data by utility programs

Dealer Inquiries Welcome.

Q. What is the DataSentry system?

A. The DataSentry protection system consists of a combination of a hardware encryption device - Personal Access Key - and associated software that runs on an IBM or compatible PC having a parallel printer port and a floppy disk drive. The DataSentry provides three types of security: mandatory use of the access key to open a file, encryption and password protection.

Q. What is inside the Personal Access Key?

A. Inside each pocket-sized Personal Access Key is a proprietary custom-designed integrated circuit, often referred to as an Application Specific Integrated Circuit (ASIC). This ASIC was designed by engineers at Rainbow Technologies specifically for the DataSentry system. The full capabilities of the ASIC are known only to Rainbow. In operation, the proprietary ASIC implements a special function called an algorithm, chosen from many thousands of possible algorithms when the key is being manufactured at the Rainbow factory.

Q. What is the disadvantage of password-only software protection?

A. The main disadvantage of password-only protection is that users find it difficult to remember a password unless it is something quite familiar to them - like their spouse's name, their dog or the street they live on. It was recently estimated that about 75% of ARPANET passwords could be discovered by trying these three choices. Choosing a less familiar name requires that it be written down. This, of course, is a security risk. As a result, password-only protection is fairly easy to defeat.

Q. What is the advantage of external hardware keys over internal security boards?

A. Some protection systems depend on circuit boards being installed inside the PC. In addition to objection to the expense of installation and training, many users are reluctant to open their PCs. IBM PS/2s and laptop PCs do not accept the standard add-in boards. As a result, nearly all PC users have a strong preference to the addition of low-cost external hardware to achieve the desired protection.

Q. Is the DES (Data Encryption Standard) government-specified algorithm available with the DataSentry system?

A. Yes. The DES algorithm as defined by U.S. government standard FIPS 46 is implemented in the DataSentry system.

Q. Can the DataSentry system be used on local area networks?

A. Yes. It can be used on LANS as long as the automatically protected files are stored on a local computer. It does not matter if the application is stored on the local PC, on a shared file server or on any other PC.

Q. Can a DataSentry system be used to secure mainframe data files?

A. Yes. The mainframe could send files to the PC for encrypting or decrypting.

Q. What are some of the new special features of the DataSentry system?

A. Audit trail, log-on identifiers, and automatic encryption/decryption of entire directories.

To consult Dr. Jennings and the DataSentry sales staff about your personal data security questions, call Rainbow Technologies today.



RAINBOW TECHNOLOGIES

18011-A Mitchell South, Irvine, CA 92714 • (714) 261-0228 • TELEX: 386078 • FAX: (714) 261-0260
Rainbow Technologies, Ltd., Shirley Lodge, 470 London Rd., Slough, Berkshire, SL3 8QY, U.K., Tel: 0753-41512, Fax: 0753-43610

© 1989 Rainbow Technologies. All product names are trademarks of their respective manufacturers.

Photo 5: We installed the DigiBoard Com/8i intelligent multiport board (\$1195) in our workstation so that we could attach up to eight terminals to the asynchronous DB-25 connectors.

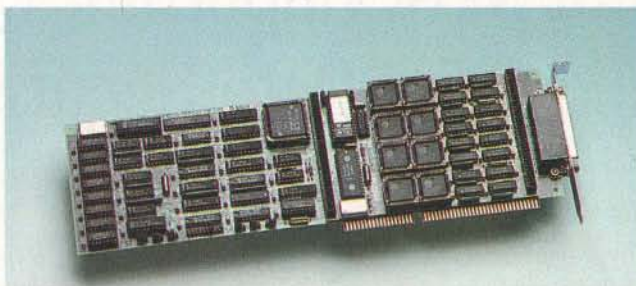
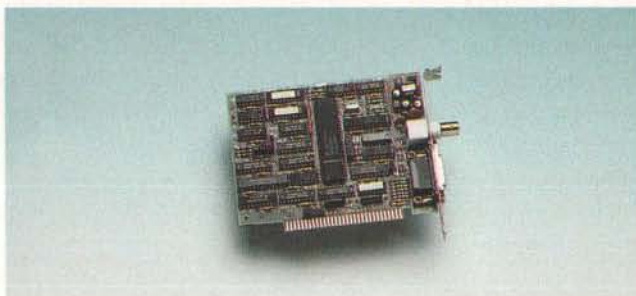

Photo 6: An EtherCard Plus from Western Digital (\$399) allowed us to connect to either a standard Ethernet LAN coaxial cable or a Thin Ethernet cable.



you could go with one of the many VGA adapters on the market. Although they usually support resolutions to 800 by 600 pixels (or 1024 by 768 pixels in only 16 colors), the prices are considerably lower. The Orchid Designer VGA is a good choice. For \$545, you can get 512K bytes of video RAM along with 800- by 600-pixel resolution in 256 colors or 1024- by 768-pixel resolution in 16 colors. Other offerings include the Paradise VGA-Plus (\$399) and the 16-bit AST-VGA Plus (\$599).

Odds and Ends

We addressed the connectivity issue from two different perspectives. Intelligent multiport boards have become an attractive option in the Unix world, especially for those users who don't have access to an existing LAN. These boards provide eight or more ports from one card, allowing you to connect multiple terminals directly to the central computer. The boards use their own CPU to manage independent parity checking and flow control, thereby freeing the system CPU from these tedious and time-consuming chores. On-board RAM enables file buffering and priority queuing of I/O jobs.

The DigiBoard Com/8i sports a 10-MHz Intel 80188 processor and 256K bytes of RAM (see photo 5). Given enough 16-bit

"Superdisk" contains drivers for most major LAN software packages, including Novell's Advanced NetWare, Western Digital's ViaNet, Sun's PC-NFS, DEC's DECnet-DOS, and 3Com's 3+. A NetBIOS/Open Systems Interconnection interface supports Microsoft's MS-NET, and a complete TCP/IP package is also available.

You might consider a few other options to complete your new system. We solicited a Tecmar QIC-60E tape backup system but did not receive the unit in time for installation. You can pick up a good backup system for about \$700. A serial mouse enhances the user interface, or, for intensive CAD work, you could select a digitizing tablet for graphics input (see the January Product Focus). Other options would depend on your applications.

Test-Driving the BYTE Lab 80386

Our complete system no doubt qualifies as a high-end personal workstation: dual 20-MHz 80386 and 10-MHz 80286 processors, 4 megabytes of 32-bit memory, a 20-MHz 80387 math coprocessor, an 84-megabyte SCSI hard disk drive, a 19-inch monitor supporting 1024- by 768-pixel graphics in 256 colors, eight intelligent asynchronous ports or an Ethernet connection, and standard serial/parallel ports. (Table 1 shows the price tag for the upgrade.)

Something, though, seemed to be lacking. Perhaps it was the underlying 16-bit AT bus or the problems enabling 32-bit conventional memory. Or maybe it was the benchmark results. Although the figures emphasize an impressive boost in performance compared to that of the original machine, the results placed our system in the same category as a standard 16-MHz 80386 computer. Or maybe it was just the familiar beige case that housed it all.

The 80386 enhancement boards are great for injecting some fresh blood into your tired 80286 system. And yet, to achieve the high performance required by a full-blown graphics workstation, you should build on a sturdy 32-bit foundation. All your expensive high-end components are, in the end, stunted by the AT architecture.

In fact, if your 80386 must take the 16-bit highway, your AT is actually degraded by the introduction of wait states. As the prices of low-end 80386 machines continue to fall, it will be-

Table 1: When we tallied our tab at the end of our AT upgrade project, our costs totaled \$13,507.

Component	Price
AOX Master 386 (20 MHz)	\$1895
Intel 80387 coprocessor (20 MHz)	\$1150
AOX Master memory board (with 4 megabytes)	\$3120
Columbia SCSI drive system (with host adapter)	\$1645
NEC MultiSync XL 19-inch monitor	\$3499
NEC MVA 1024 video adapter (with memory option)	\$1799
Western Digital EtherCard Plus	\$399
Total:	\$13,507

THE ULTIMATE UPGRADE

COMPANY INFORMATION

AOX, Inc.
486 Totten Pond Rd.
Waltham, MA 02514
(617) 890-4402
Inquiry 1162.

AST Research, Inc.
2121 Alton Ave.
Irvine, CA 92714
(714) 863-1333
Inquiry 1163.

Columbia
Data Products, Inc.
851 West 436, Suite 1061
Altamonte Springs, FL
32714
(407) 869-6700
Inquiry 1164.

Consensus Corp.
1301 Pat Booker Rd.
Universal City, TX 78148
(800) 387-8951
Inquiry 1165.

CORE International
7171 North Federal Hwy.
Boca Raton, FL 33431
(407) 997-6044
Inquiry 1166.

DigiBoard, Inc.
6751 Oxford St.
St. Louis Park, MN 55426
(612) 922-8055
Inquiry 1167.

Distributed Processing
Technology
132 Candace Dr.
Maitland, FL 32751
(407) 830-5522
Inquiry 1168.

Intel Corp.
5200 Northeast Elam
Young Pkwy.
Hillsboro, OR 97124
(800) 538-3373
Inquiry 1169.

NEC Home Electronics, Inc.
1255 Michael Dr.
Wood Dale, IL 60191
(312) 860-0335
Inquiry 1170.

Orchid Technology, Inc.
45365 Northport Loop W
Fremont, CA 94538
(415) 683-0348
Inquiry 1171.

Paradise Systems, Inc.
99 South Hill Dr.
Brisbane, CA 94005
(415) 468-7300
Inquiry 1172.

Priam Corp.
20 West Montague Expy.
San Jose, CA 95134
(408) 434-9300
Inquiry 1173.

The Santa Cruz Operation
(SCO)
400 Encinal St.
P.O. Box 1900
Santa Cruz, CA 95061
(408) 425-7222
Inquiry 1174.

Tecmar, Inc.
6225 Cochran Rd.
Solon, OH 44139
(216) 349-0600
Inquiry 1175.

Western Digital Corp.
2445 McCabe Way
Irvine, CA 92714
(800) 847-6181
Inquiry 1176.

Western Digital Imaging
800 East Middlefield Rd.
Mountain View, CA 94043
(415) 960-3353
Inquiry 1177.

come harder to choose the upgrade path. You might as well sell out and go with the packaged product. If you're a die-hard do-it-yourselfer, start with a 32-bit motherboard and build from there. That special sense of accomplishment loses its luster when the final product can't quite do the job. ■

Stanford Diehl is a testing editor for the *BYTE* Lab. He can be reached on BIX as "sdiehl."

Protects while you type!

- **Remains In Place** while you use your computer.
- **Avoids Costly Repairs.** Protects delicate electronics from dust, spills, smoke, ashes, staples.
- **Soft, Flexible,** retains normal keyboard feel.
- **Washable, Durable High-Tech Polymer** lasts years.
- **Hundreds of Models.** SafeSkin is available for most PCs, laptops, workstations and clone keyboards.
- **Office • Home • Factory • Classroom • Laboratory**

List Price \$29.95. Please call or write for free color brochure. Dealer inquiries encouraged.

SafeSkin™
Keyboard Protector

Merritt Computer Products, Inc./4561 S. Westmoreland
Dallas, Texas 75237/(214) 339-0753 • Fax (214) 339-1313
In Canada call 1-800-663-1061

Protect Your Copies of **BYTE**

NOW AVAILABLE: Custom-designed library files or binders in elegant blue simulated leather stamped in gold leaf.

Binders—Holds 6 issues, opens flat for easy reading.
\$9.95 each, two for \$18.95, or four for \$35.95.



Files—Holds 6 issues.
\$7.95 each, two for \$14.95, or four for \$27.95.



Order Now!

Mail to: Jesse Jones Industries,
Dept. BY, 499 East Erie Ave.,
Philadelphia, PA 19134

CALL TOLL FREE (24 hours):
1-800-972-5858

Please send _____ files;
binders for *BYTE* magazine.

Name: _____

Enclosed is \$ _____.
Add \$1 per file/binder for postage and
handling. Outside U.S.A. add \$2.50 per
file/binder (U.S. funds only please).

Address: _____
(No Post Office Box)

Charge my: (minimum \$15)

City: _____

____ American Express
____ Visa _____ MasterCard
____ Diners Club

State: _____ Zip: _____

Satisfaction guaranteed. Pennsylvania residents add 6% sales tax.
Allow 3-6 weeks delivery in the U.S.

Card # _____
Exp. Date _____
Signature _____

BYTE

"Is there something we missed?"



Is there anything missing in the ACCEL-500 24-pin dot matrix printer?

Not performance. The ACCEL-500 can zoom through drafts at 480 cps. Print charts and graphs in dazzling color. And combine letter quality with high resolution color graphics.

Not versatility. The ACCEL-500 is compatible with most popular printers. So it's equally at home on Macintosh® and IBM®-compatible PCs. There's a paper-handling option for every office application, too.

Not convenience. The ACCEL-500's innovative Select-Dial™ makes paper handling a snap. And plug-in Intelli-Cards™ add fonts and printer emulations instantly.

Not reliability. The ACCEL-500 is a 'round-

the-clock workhorse that takes even the most demanding workload in stride.

And certainly not value. The ACCEL-500 is priced below leading printer brands that offer far less capability.

In fact, it seems that the only thing missing from the ACCEL-500 is you.

ACCEL-500™

Advanced Matrix Technology

765 Flynn Road, Camarillo, CA 93010

(800) 992-2264

(805) 388-5799

MODERN MODEM METHODS

Clever modulation lets modems pack more into each second of communications

As we enter the 1990s—the second decade of the “computer revolution”—telecommunications will become an increasingly important part of what computers do for us. And whenever computers communicate over distances too great to be covered by a LAN (or even over smaller distances), the odds are overwhelming that a modem is somewhere in the loop. In this month’s installment of “Under The Hood,” I’ll take a close look at how modern modems achieve high performance on regular, voice-grade phone lines. [Editor’s note: *For a practical look at how modems perform using these new techniques, see this month’s Product Focus on page 162.*]

Modulation Methods

The first and simplest modems used *frequency-shift keying* (FSK) to encode data. In FSK, the transmitted signal shifts back and forth between two frequencies: one representing a 1 and the other representing a 0. (In a sense, FSK is nothing more than a very simple form of frequency modulation.) Your modem probably uses FSK when it runs at 450 bps or less.

Frequency is only one characteristic you can vary to impress a signal upon a carrier. Another is *phase* (the position of the repetitive waveform of the carrier in time). Figure 1b shows two carrier signals that have the same shape but different phases. Both are sine waves of the same frequency and amplitude and can be represented by the equation

$$m(t) = A \cos(2\pi ft + \phi)$$

where t is the time, A is the amplitude of the carrier, f is the carrier’s frequency, and ϕ (the Greek letter phi) is its phase. Only ϕ differs between the two waves shown; it’s 0 for the top signal and 180 degrees (or π radians) for the bottom signal. This difference lets you shift the bottom signal a quarter of a cycle to the right.

If you were to shift the bottom signal 180 degrees more, it would look identical to the top one. (As you may remember from geometry, an angle of $\phi + 360$ degrees—or 2π radians—is indistinguishable from an angle of just ϕ .)

Phase-shift keying (PSK) uses shifts in phase to signal 1s and 0s. How does it represent the bits in terms of phases? Suppose I had a PSK modulator that could transmit a sine wave with two possible phases separated by 180 degrees (the maximum possible separation). I could let one phase represent a 1 and another a 0; however, without two well-synchronized clocks—one at each end—the receiver would have no way of knowing which was which.

To avoid this problem, most PSK systems don’t assign a logic level to each phase. Instead, they use a *phase transition* to indicate one logic level or no transition to indicate another. This is called *differential phase-shift keying* (DPSK). Table 1 defines a possible set of transition rules.

Phase-encoding schemes are often shown graphically with *phase-amplitude diagrams* (see figure 1). In this diagram, each possible phase and amplitude of the carrier can be represented by a point on the polar representation of a plane. The length of a straight line from the origin to a given point represents the amplitude; the angle made by the same line with the positive side of the horizontal axis represents the phase. Figure 1 shows the possible signals—or symbols—of the two-phase DPSK system described in table 1. Figure 1c, sometimes called a *phase-transition diagram*, adds arcs to show the

transitions (or nontransitions) caused by 1 and 0 data bits.

The number of phase transitions per second in a PSK system is limited by the frequency of the carrier and the available bandwidth; typically, the transition rate can’t exceed half the bandwidth. Thus, if you divide a phone line with 2400 Hz of bandwidth into two channels (one in each direction), you can have no more than 600 phase transitions per second on each channel.

This means that a PSK modem is limited to 600-bps operation over a normal phone line if you limit yourself to the two-state PSK method. However, it doesn’t hold true if you use four possible phases instead of two, thus packing more than one bit of information into each phase transition. The pattern of possible states, usually called a *constellation*, is shown in figure 2. It allows four possible transitions (one of them back to the same state) from each of the four symbols—letting each transition signal the values of two data bits. Each of these symbols is called a *dibit*.

As in most data-encoding techniques that depend on transitions, DPSK encoding schemes must transmit the data synchronously and guarantee a certain number of transitions per unit time so that the receiver can synchronize with the transmitter’s clock. To make sure that a long string of zeros—or any data pattern—doesn’t cause a long period without transitions, DPSK modulators usually contain a *scrambler*. The scrambler doesn’t destroy the data, but it makes the distribution of 1s and 0s sent over the line more even. A descrambler at the receiving end recovers the original data from the demodulated data stream.

The scrambler has one negative effect on modem performance: It has a tendency to amplify errors. One error received by the demodulator becomes three or more after it passes through the scrambler—some up to 17 bits later. The

continued

result is the $\{j\}$ or $\{ \}$ pattern you often see when there's noise on the line.

Quadrature Amplitude Modulation

I've just shown how a four-state PSK modulation scheme lets you exchange data at 1200 bps over an ordinary phone line. But what if you want to go faster still? You could create an eight-state PSK system. Small differences in phase alone are hard to detect, and each error could cause as many as 6 bits to be received incorrectly, each of these errors compounded by a scrambler. Since the result would be a modem that was overly sensitive to line noise, a simple eight-state PSK system is seldom used.

If you vary amplitudes as well as phases, you can create more states without the weakness of a simple eight-state PSK system. This scheme is called Quadrature Amplitude Modulation, or QAM (see figure 3). Its robustness comes from the fact that there is a greater distance between the states, thereby giving the demodulator more information with which to deduce the correct bit pat-

tern. Most 2400-bps modems, including ones that use the CCITT V.22-bis standard, use QAM.

Extending QAM: Trellis Coding

A 2400-bps V.22-bis modem uses a QAM constellation consisting of 16 possible symbols (12 possible phase angles and three amplitudes). It transmits 600 symbols per second; each conveys 4 bits of information and is called a *quadbit*.

If it were possible to transmit signals of arbitrary amplitude over the phone line, it would be easy to keep the symbols apart as you add more of them to the diagram. But the dynamic range of a phone line is limited; by the time you reach a speed of 9600 bps, it's necessary to start packing the QAM symbols more closely in the phase-amplitude plane.

Trellis coding can reduce the number of errors this "tighter" pattern generates. In trellis-coded modulation, the constellation contains more symbols than are necessary to represent all the possible bit combinations, but not all transitions are possible. If the receiver sees a symbol that falls between the points of the constellation, it can use its knowledge of the previous symbols to rule out certain illegal symbols and choose the closest one that remains. Trellis coding also spreads the information needed to decode each bit among several symbols. The result is about 4 decibels (a little more than double) the signal-to-noise ratio of a nonencoded system.

Full-duplex 9600-bps modems that conform to the CCITT V.32 standard use trellis coding. They also have special circuitry to cancel echo noise. Echo-cancellation circuits can be complex and expensive to implement; they're the main reason modem manufacturers haven't unanimously embraced the V.32 standard. This will probably change now

that companies like Rockwell are hard at work on complete V.32 modems that fit on only a few chips.

The demand for high-speed modems didn't wait for VLSI technology to catch up, however. In the absence of a clearly defined industry standard, modem makers have forged ahead with their own standards, some of which are vastly different from V.32. (See "High-Speed Modems" by John H. Humphrey and Gary S. Smock in the June 1988 BYTE.) The two most widespread (and novel) of these are Telebit's Packet Ensemble Protocol (PEP) and USR's High-Speed Technology (HST).

HST: An Asymmetrical Approach

USR's HST modems are *asymmetrical full-duplex modems*. They divide the available bandwidth into two asymmetrical channels—a high-speed channel in one direction (14,400, 12,000, 9600, 7200, or 4800 bps) and a low-speed channel in the other (450 bps). The 450-bps channel is more than adequate to handle the output of the fastest typist; the high-speed channel is well-suited for fast screen updates and downloads. (The two channels can change places when appropriate—during uploads, for instance.) The high-speed channel always uses trellis coding, but it adjusts the data rate and constellation according to line conditions. HST uses the V.32 constellation up to 9600 bps, and the constellation from V.33—a leased-line standard—at higher speeds. With data compression, the net throughput of an HST modem can be as high as 17,500 bps.

Half-duplex modems don't keep channels open in both directions simultaneously. They must "ping-pong" (i.e., change the direction of transmission periodically) to handle data traveling in both directions. Because HST modems

Table 1: Differential phase-shift keying. This table shows a possible set of transition rules for a two-phase DPSK modulation scheme. The phase shifts by 180 degrees to indicate a 1 bit but does not change for a 0 bit.

bit	ϕ	ϕ
0	0	0
0	180	180
1	0	180
1	180	0

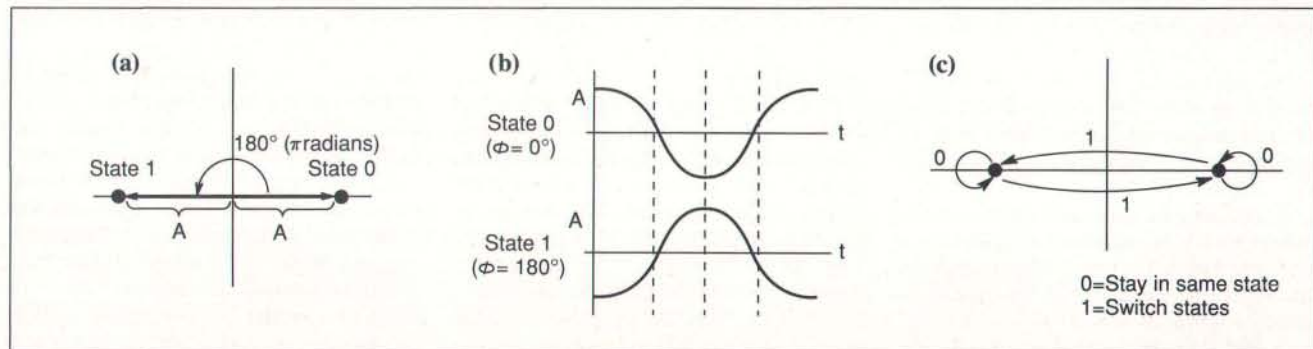
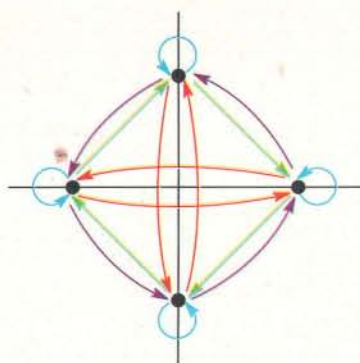

Figure 1: The states and transitions for a two-state differential phase-shift keying modulation scheme. (a) The amplitude, which is the same for all states in PSK, is represented by the length of the line joining each point to the origin, while the phase is represented by the angle of that line relative to the positive half of the horizontal axis. (b) Two carrier signals that have the same shape but are 180° out of phase. (c) A possible way of encoding 1 and 0 bits as transitions between the states.

always keep a slow channel open in the "reverse" direction, this *round-trip echo response time*—the delay between the time you press a key and the time you see a response—is lower than for a half-duplex modem.

A Thousand Twanging Instruments
Telebit Corp.'s Trailblazer modems, which have gained popularity in the Unix world, use a patented technique called Dynamically Adaptive Multicarrier Quadrature Amplitude Modulation (DAMQAM) (see figure 4). This scheme uses a large number of very small channels—up to 512 of them, spaced only 7.8125 Hz apart. Some quick multiplication shows that the total bandwidth required to use all the channels would be



- (0,0) = Stay in same state
- (0,1) = Move one step counterclockwise
- (1,0) = Move one step clockwise
- (1,1) = Move to state opposite current state

Figure 2: Four-state differential phase-shift keying. This phase-amplitude diagram shows a set of states and transitions for a four-state DPSK modulation scheme.

In the absence of a clearly defined industry standard, modem makers have forged ahead with their own standards.

rate of 7.8 Hz, each packet took a minimum $\frac{1}{4}$ second to transmit. To solve this problem, Telebit recently added another modulation scheme that divides the available bandwidth into channels about 88 Hz wide; packets sent at this speed (called micropackets) get through 10 times faster and give you a better "feel" during interactive sessions.

Protocol Spoofing

The Telebit modems have another noteworthy feature that makes them especially good for bulk-file transfers. Since PEP has its own error correction and pacing mechanisms built into most file transfer protocols (e.g., Kermit, XMODEM, YMODEM, and the UUCP G protocol) are redundant. In fact, if the modems at both ends must "turn the line around" (i.e., switch directions) to transfer acknowledgment sequences (e.g., XMODEM's ACK character or Kermit's short Y packets), the transfer will proceed much more slowly.

Telebit solves this problem by implementing a feature called *protocol spoofing*. When it recognizes that a protocol transfer is going on, the modem on the sending side of the transfer assumes responsibility for getting each packet through and acknowledges blocks of data on behalf of the receiver. The modem at the receiving end does its part by "absorbing" the receiving system's acknowledgment packets rather than sending them back. As a result, it virtually eliminates delays in the line and delays due to turnaround time.

It's theoretically possible for any error-correcting modem to do protocol spoofing (and especially desirable for

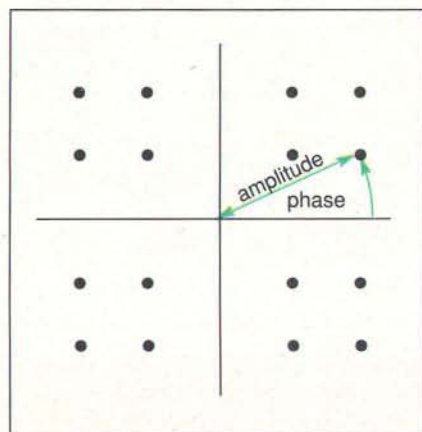

Figure 3: A Quadrature Amplitude Modulation constellation. Each point in the graph of a 16-point constellation represents a phase-amplitude state that the encoding scheme uses. CCITT V.22 bis uses a 16-point constellation.

4000 Hz—more than the rated bandwidth of a basic voice line (specified to be only 400 to 3000 Hz). However, the modem does not expect to be able to use all these channels; instead, it tests each one individually to see if it can be used.

It's possible to use different modulation schemes on different channels; some of the lower-quality channels can be encoded with two-phase DPSK, while the better ones use 4- or 6-bit QAM. On a typical dial-up line, a Telebit modem uses 400 channels in the range from 300 to 3400 Hz, encompassing more bandwidth than a less adaptable scheme.

Trailblazer modems are half-duplex and use a special protocol (Packet Ensemble Protocol, or PEP) to exchange packets of data by distributing the bits across the available channels. The original Telebit modems were excellent at handling large volumes of data because of high bandwidth utilization, but they had poor echo response—at a signaling

half-duplex modems). At present, however, Telebit is the only manufacturer offering this feature.

Other Schemes

USR and Telebit's high-speed modulation techniques, while the most interesting, are not the only proprietary schemes that operate at 9600 bps and above. The Hayes V-series modems, for instance, use a half-duplex scheme based on V.32. Microcom's MNP Class 6 and the FASTCOMM UPTA modems use the half-duplex CCITT V.29 modulation scheme—the same one used in fax machines. Table 2 shows a comparison of some of the most popular schemes.

Who will win the high-speed modem "protocol wars"? At the time of this writing, there's no clear winner among

continued

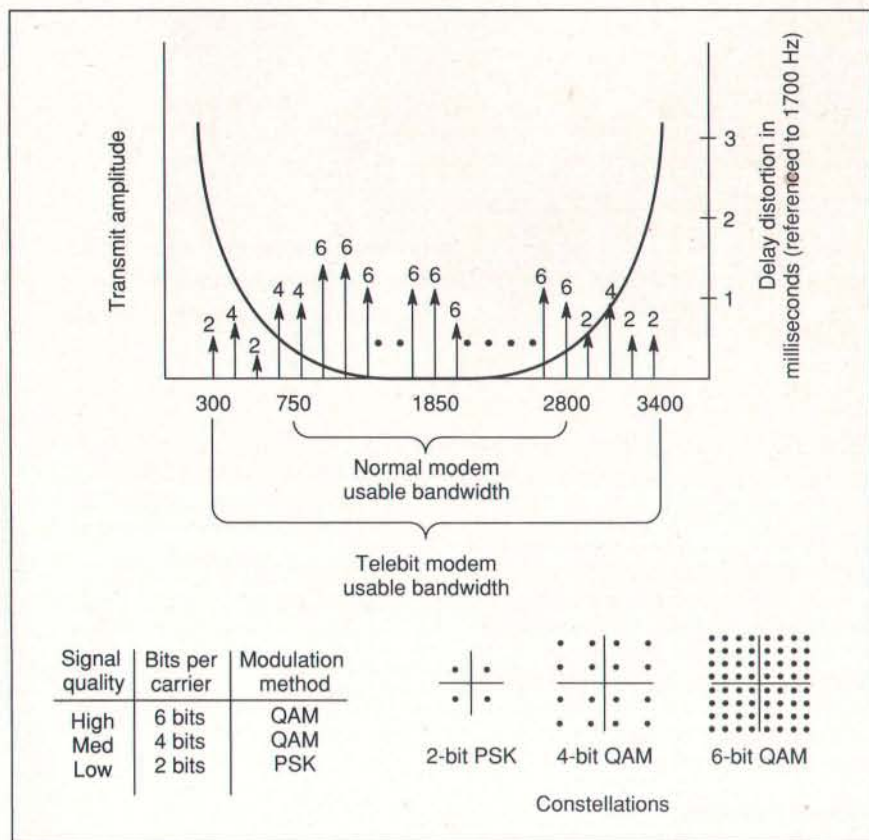

Figure 4: Telebit's Dynamically Adaptive Multicarrier Quadrature Amplitude Modulation encoding scheme. The Telebit Trailblazer modems use many small channels, modulated at low speeds, to make the best use of a phone line's available bandwidth. The signal quality of each 7.8-Hz channel determines what modulation scheme, if any, is used for that channel.

Table 2: A comparison of the modulation schemes.

	Bit rate	Modulation	Duplex	Round-trip echo response time (approx.)
Hayes V-series	9600	Trellis-coded QAM (based on V.32)	Half	140 ms
USR HST	14,400 12,000 9600 7200 4800	Trellis-coded QAM (based on V.32 or V.33)	Full (asymmetrical)	140 ms
Microcom MNP Class 6	9600	V.29	Half	155 ms
Telebit PEP	Variable up to 18,000	Multicarrier QAM or PSK	Half	≥ 250 ms (ordinary packets) ~ 100 ms (micropackets)
V.32	9600 4800	Trellis-coded QAM	Full	100 ms

the proprietary protocols, but it looks as if nearly all manufacturers are preparing to offer compatibility with the CCITT V.32 standard. Some will make V.32 their primary standard, while others—the ones with the largest investments in proprietary schemes—will offer it as an option. (Initially, V.32 modems will cost more than most others, but prices should fall once VLSI implementations are available from multiple chip vendors.)

The bottom line: If you need a fast modem now but want to be sure you will be able to speak the lingua franca of high-speed modem standards a year or two down the road, you may want to ask your vendor if it provides—or at least promises—an upgrade path to V.32.

Error Correction and Modems

As modems reach speeds beyond 2400 bps, errors become common enough that there's a real need for automatic error correction within the modems themselves. Usually, this is done via a packet-oriented protocol in which packets of data are bundled with a cyclic redundancy check (CRC) designed to catch errors.

The two major contenders among modem error-correction protocols are MNP Classes 1 through 4, developed by Microcom, and LAPM, a standard promoted by Hayes that is based on the LAPB and LAPD link-level protocols used in X.25 and ISDN systems. Both are "windowed" packet protocols (i.e., they can send several packets in a burst without waiting for an acknowledgment).

Even the promoters of the two standards agree that there isn't much of a performance difference between MNP and LAPM; they are now covered by the CCITT V.42 standard (LAPM is a primary part of the standard, while MNP is "Annex A"). It's even possible to build a modem that incorporates both standards. At present, MNP seems to be more widespread in the marketplace, and so may be the more useful one to look for.

Error-correcting modems let you use "streaming" file transfer protocols, like YMODEM G and the Hayes FAST protocol, which implement only minimal error checking. Unless you are using a modem like the Telebit Trailblazer to communicate to another Trailblazer (in which case the protocol spoofing eliminates the acknowledgment delays in most protocols), it's probably worth your while to look into FAST and YMODEM G for use with your error-correcting modem.

continued

*By popular demand, we've extended
this program to June 30, 1989.*

FREE* SIVA 386 SYSTEM

*with the purchase of \$3295++
of software or \$4995++ of
hardware.*

Standard 386 Features:

- 32-bit Intel 80386-16 CPU.
- 1MB of 32-bit RAM on board. System expandable to 16MB.
- 8/16/20 MHz Keyboard selectable.
- ST-251-1 Seagate 40MB Formatted 28 ms high speed, with ultra high speed Controller 1:1 interleave.
- 1.2MB High Capacity Floppy Drive.
- Super deluxe heavy duty tower case with 6 half-height drive openings.
- High-resolution 12" Non-Glare Amber Display. Tilt and Swivel base, Hercules-compatible Adapter.
- 101 Key Enhanced Keyboard, Pleasant "Tactile/Click" Feel.
- 80287/387 Math-Coprocessors optional.
- Fully compatible with virtually all XT/AT and 386 software.

Upgrades for your FREE 386 System:

- VGA Color Upgrade — add only \$495.
- 20 MHz CPU Upgrade — add only \$195.
- Call for all other options and upgrades.

Choose Your Hardware

A hardware purchase of \$4995 or more is required to receive the SIVA 386 System FREE.

- | | |
|---|--------|
| • QMS PS 810 Postscript Laser Printer | \$5495 |
| • CDC WREN IV 300MB SCSI Hard drive with Controller | \$2595 |
| • CDC WREN III 155MB SCSI Hard drive with Controller | \$1795 |
| • CDC WREN II 86MB ST506 Hard drive with HD/FD Controller | \$ 895 |
| • Eight Port RS232 Intelligent Card with Xenix Driver | \$ 995 |
| • 32-Bit 8MB Memory Expansion Board | \$2997 |
| • Intel 80387 — 16 Coprocessor | \$ 495 |

Software

- | | |
|---|--------|
| • Complete SCO Xenix System (including Operating System, Developing System and Text Processing System for 80386-based System) | \$1595 |
| • SCO Lyrix System | \$ 595 |
| • SCO Professional | \$ 895 |
| • SCO Integra | \$1295 |
| • SCO Foxbase Plus | \$ 995 |
| • SCO VP/IX (integrated DOS environment — two users) | \$ 495 |
| • Language & Development Tools | CALL |
| • Networking & Communication Packages | CALL |

A software purchase of \$3295 or more is required to receive your FREE SIVA 386 System. Mix and match to meet your needs!



Ask about our Professional Services:

- Data Processing and Network Consulting
- Application Development and Training
- System Administration
- Hardware and Software Installation & Support

1-800-252-4212

VNS America Corp.

Suite 270, 910 Boston Post Road
Marlboro, Massachusetts 01752 U.S.A.
In Massachusetts 508-481-3726
FAX: 508-481-2218

All prices subject to change without notice.

DATASTAR 5. MAKING ALL OTHER LAPTOP MODEMS OBSOLETE

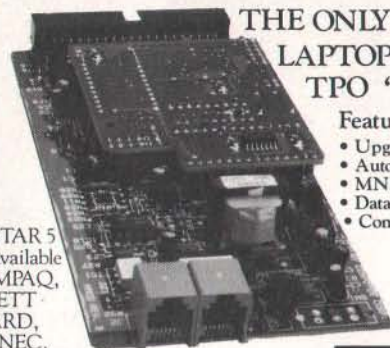

THE ONLY UPGRADEABLE 2400 bps
LAPTOP MODEM WITH MNP5 &
TPO "True Power Off"

Features

- Upgradeability
- Automatic TPO "True Power Off"
- MNP5 - 100% error free transmission
- Data Compression - 4800 bps throughput
- Compatibility - "AT" and "Extended AT" command sets.
 - Ease of installation
 - 3 year warranty
 - High performance - custom low distortion phone interface

DATASTAR 5 is now available for COMPAQ, HEWLETT PACKARD, BULL, NEC, TOSHIBA, and ZENITH laptop computers.



216 Matheson Blvd. East, Mississauga, Ontario Canada L4Z 1X1
(416) 890-1956 FAX (416) 890-8329

All trademarks are property of their respective manufacturers

DATASTAR 5

BBS Sysops

Are you looking for ways to improve your board? Something that will set you apart from other boards in your area? Are your subscribers interested in Microcomputers? Listen to this!

Announcing the Bulletin Board EXchange

The Bulletin Board Exchange allows you to become a publisher of MicroBYTES Daily, an on-line news service from BYTE. Bulletin Board Exchange/MicroBYTES is a custom package of news and features designed especially for local BBSes, and is available only to sysops.

Every Monday through Friday you get articles about developments in microcomputing, telecommunications and selected new product announcements. Get the latest news about MS DOS machines, Macintoshes, Unix workstations, Amigas, Atari STs, peripherals and software. All the stories are reported, written, and edited by the staff of BYTE magazine, BYTEweek and BIX, and our world-wide network of reporters and editors.

Not only do you get a great resource for your subscribers, but you also get access to BIX which will cut your cost of exchanging information and conducting BBS network business.

All this is just \$49 a quarter.

Your one-year subscription to the Bulletin Board Exchange (billed quarterly) may be cancelled any time without further charge; just notify us. If you prefer, you may subscribe for three months only, at just \$69.

If you call BIX direct, you pay no hourly telecommunications charge. If you call using Tymnet, the rates are only \$2/hour on evenings and weekends and \$8/hour on weekdays. You may also purchase unlimited off-peak Tymnet for just \$15 a month.

Subscribe today.

BIX

One Phoenix Mill Lane
Peterborough, NH 03458
800-227-2983
In NH 603-924-7681

Compression

Most high-end modems offer data compression as well as error correction. The most commonly implemented standard is MNP Class 5, which must be licensed from Microcom. USR, Telebit, and others implement this standard. The high-end Telebit modems use MNP only up to speeds of 9600 bps; at higher rates, they use a proprietary Lempel-Ziv algorithm integrated into the PEP protocol. Hayes's V-series modems also offer data compression.

Microcom claims that it can obtain a 60 percent increase in average throughput as a result of data compression; this is a typical number for most compression schemes. The mileage that you get may vary, of course, depending on the amount of redundancy in the data that you're transferring. And, of course, the modem at the other end must implement the same compression algorithm that yours does. This is another reason to look carefully at the fine print when choosing a modem.

Will Modems Soon Be Obsolete?

Many have said that, with the advent of ISDN, modems will soon become obsolete. The odds are that this will indeed happen, but probably not "soon"—it may take a long time before ISDN is available outside large cities and major corporate plants (currently, the only installations). If you buy a high-speed modem now, you can expect to get at least a decade's use from it before you retire it to the closet and plug your computer directly into a data outlet in your wall. ■

BIBLIOGRAPHY

Bingham, John A. C. *The Theory and Practice of Modem Design*. New York: John Wiley & Sons, Inc., 1988.

Microcom Networking Protocol Specification, Link Service Classes 1-4. Norwood, MA: Microcom, Inc., 1987.

Packetized Ensemble Modem. U.S. Patent 4,438,511 [Paul Baran], Washington, DC: U.S. Patent and Trademark Office, 1984.

Transmission Systems for Communications. 5th ed. Holmdel, NJ: Bell Telephone Laboratories, Inc., 1982.

L. Brett Glass is a freelance programmer, author, and hardware designer residing in Palo Alto, California. He can be reached on BIX as "glass."

Your questions and comments are welcome. Write to: Editor, BYTE, One Phoenix Mill Lane, Peterborough, NH 03458.



Part 2

DIRECTORY ASSISTANCE

The tour of file-systems continues, with stops at MS-DOS, Unix, and the Macintosh HFS

These days, many of us use more than one computer, often running different operating systems. Most of us also use hard disk drives, which are growing larger every day. Those large hard disk drives place a greater burden on an operating system's directory structure. Understanding the directory structure of your operating system can help if (or when) something goes wrong with your hard disk drive.

Last month, I looked at the file-systems of three classic operating systems: Apple DOS 3.3, ProDOS, and CP/M. This month, I'll examine three operating systems that are currently in wider use: MS-DOS, Unix, and the Macintosh Hierarchical File System (HFS).

MS-DOS

The MS-DOS file-system structure has some strong similarities to CP/M's structure (see last month's column): The directory information is stored on contiguous sectors following the boot sector (and reserved sectors used for partitioning information), each entry in a directory is 32 bytes long, and files claim space in multisector clumps referred to as *clusters* (similar to the CP/M allocation block).

To make the similarities apparent, I've left out some details. Actually, the layout of an MS-DOS disk looks something like this:

Boot sector
Reserved sectors
FAT
FAT copy (optional)

Root directory
Everything else (files and subdirectories)

The FAT is the file allocation table, a linked-list structure that's intimately tied to the directory, as you'll soon see.

The system can deduce the specifics of where important structures are located on a disk by examining key locations in the boot sector (logical sector 0). Some of the more important entries in the boot sector are as follows (a word is equivalent to 2 bytes):

- Number of bytes per sector—a word value at offset 11.
- Number of sectors per FAT—a byte value at offset 22.
- Number of FATs on the disk—a byte value at offset 16.
- Number of entries in the root directory—a word value at offset 17.
- Number of reserved sectors—a word value at offset 14.
- Number of sectors per cluster—a byte value at offset 13.

An MS-DOS directory entry consists of a filename, an extension, an attribute byte, the time and date that the file was created (or last modified), a pointer to the file's starting cluster, and the size of the file in bytes. (See figure 1 for a diagram of a directory entry's layout.)

The first byte of the filename is significant: A 00 (null) indicates that the entry has never been used and is therefore the directory's current "high-water" mark. A hexadecimal E5 in the first position indicates that the entry has been deleted. (If a deleted file is a fresh kill—in other words, if you haven't done any write operations to the volume that the file was on—then the remainder of the file's information is intact. This is what allows undelete utilities to work.) Finally, a 05 as the first character indicates that the first character is really a hexadecimal E5

(which, on my AT clone, maps to a lowercase Greek sigma). Any alphanumeric character implies a real file and is part of the file's name.

The file-attribute byte is actually a set of bit fields that indicate whether the file is hidden, if it has been archived, whether it's read-only, and so on (see table 1). This byte is also used to indicate a subdirectory entry, in which case the entry's starting cluster-number pointer indicates a cluster that holds the entries of the subdirectory.

Subdirectories always begin with the familiar "." and ".." that are the first to come rolling out after you've issued a DIR command. The "." element is a self-referencing entry whose starting cluster number points to the head of the current directory. This allows a program to find the beginning (and therefore the contents) of whatever your current directory is—no matter how many subdirectories deep you may have wandered into the volume.

The ".." entry references the parent; The starting cluster number of ".." points to the head of the subdirectory's parent's directory. As you issue CD (change directory) commands, moving into subdirectories of subdirectories, the system can always find the route back to the root directory by following the trail of ".." entries.

The system locates a file's contents by following an imaginary thread through the FAT. In figure 1, you can see that the file entry's starting cluster number actually points to two things. Not only does it give the starting cluster of the file's data, it also acts as an index into the FAT: specifically, an index to the first FAT entry in a chain that guides you to the location of the rest of the file.

Each entry in the FAT corresponds to a cluster on the volume. So, assume your file's first cluster number is 4. To find the file's second cluster number, locate the entry in the FAT corresponding to

continued

cluster 4; it'll point to another cluster number (say, 10). So, 10 is the file's second cluster. To find its third cluster number, you locate the FAT entry corresponding to cluster 10, see where that points, and so on.

FAT entries can be either 12 or 16 bits long. You'll find 12-bit FATs on disks that hold fewer than 4087 clusters (e.g., 360K-byte disks usually accommodate 354 clusters of 1K byte each). All other disks will use 16-bit FATs.

As a safety measure, some disks may maintain two FATs. Both are updated whenever the disk is modified. In this way, if one FAT becomes corrupted due to a failed sector, you can still recover files using its twin. (The CHKDSK com-

mand verifies that both FATs—if there are two—are consistent.)

Notice that the FAT is nothing more than a singly linked list. This means that, unless the system can keep the FAT in memory at all times, the file-system's response time will suffer as files grow large and fragmented. And as multiple hard disk drives become more prevalent—especially in a network environment—a FAT can consume a substantial amount of memory. For example, on my AT clone with its 20-megabyte hard disk drive, the FAT is over 20K bytes.

Unix

Unix is unique among the operating systems I'm covering in this series in that

it's a multiuser operating system. This means that the designers of Unix had considerations in mind that designers of the other operating systems didn't have to contend with. Chief among these were access and security controls, and you'll see how this affected the design.

If you stand far away, a Unix file-system looks like most of the other file-systems I've described. The disk is arranged as a series of blocks—the minimum allocation unit—each of which is usually 1K byte big (although the actual size depends on which version of Unix you're running). The first block is the boot block, and this is followed by the superblock. The superblock contains information such as the file-system size, the number of i-nodes (short for "index node"—I'll explain further in a moment) in the system, where the root directory's i-node is located, and so on. As its name implies, the root directory is the base for the entire directory structure on the file-system; you can get anywhere from the root directory. The superblock is followed by blocks used by the i-node list, which in turn are followed by file and directory data blocks.

The Unix directory structure is actually in two parts. The first holds the stuff humans are interested in: the names of the files and subdirectories. Each entry is 16 characters long and consists of a 2-byte i-node number followed by 14 bytes for the name of the file or subdirectory. The i-node number is a unique identifier for each entry in the file-system. More important, it is an index into the *i-list*, the second part of the Unix directory.

The *i-list* is a structure on the disk where Unix keeps the information that *it* is interested in. Each element of the *i-list* is an i-node, and although the detailed structure of an i-node may vary from Unix system to Unix system, its overall format is the same no matter what Unix machine you're on. As a real-world example, on the Definicon DSI-32 Unix System V that I use, the i-node layout is as shown in table 2.

Subdirectory entries look just like file entries. The only difference is a bit set in the file-mode field that marks this entry as a subdirectory. As in MS-DOS (although MS-DOS borrowed this from Unix, not vice versa), the first two entries in a Unix directory are "." and "..," referring to the current directory and the parent directory, respectively.

Since the directory consists of no more than i-node numbers and filenames, a given file's contents may be referenced by more than one path name. This is the

continued

Table 1: MS-DOS directory entry's file-attribute byte. Each bit indicates its associated attribute when set to 1.

Bit	Description
0	File is read-only.
1	File is hidden.
2	Indicates a system file (will not show up on directory displays).
3	This entry is a volume label. Such entries can exist only in the root directory.
4	The entry is a subdirectory.
5	This bit indicates whether the file has been archived; it is set to 1 whenever the file is modified.

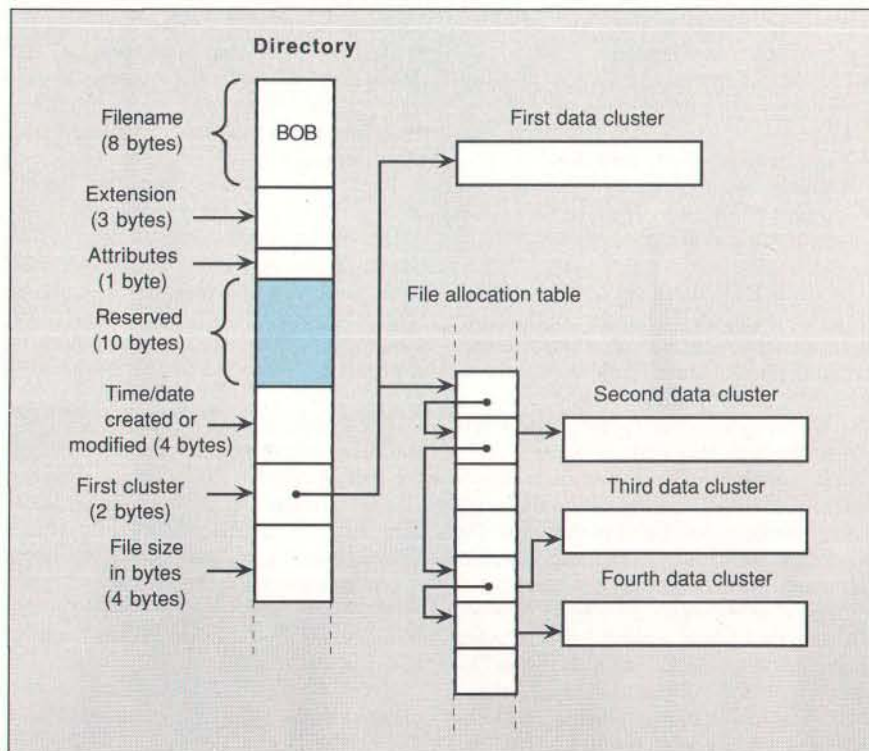

Figure 1: How an MS-DOS system finds the contents of file BOB. Note that the format of an MS-DOS directory entry is defined here.

**Turn your favorite
C compiler into a
powerful database
manager with the**

C/Database Toolchest



The **C/Database Toolchest™** adds sophisticated file management functions to your Power C™, Turbo C®, QuickC®, or Microsoft® C compiler. With the **C/Database Toolchest™**, your data requires much less disk space than with programs like dBASE®, and you can access your data much faster. Of course the full power of C provides you with an unlimited amount of programming flexibility.

The **C/Database Toolchest™** includes three major components:

- 1) An advanced B+tree library gives you instant access to your data.
- 2) A high-level ISAM library provides you with an easy-to-use C interface, and

3) A complete database manager (with C source code included) shows you how to create impressive applications.

You also receive a comprehensive 350 page manual and a utility for converting dBASE® files.

The **C/Database Toolchest™** supports features that you'd expect to find only in products costing ten times as much. Advanced features include variable length records, variable length keys, multiple keys per index, and multiple indexes stored in a single file. Your data files can contain an unlimited number of records, and each record can be as large as 32K bytes in length.

About the only thing that the **C/Database Toolchest™** doesn't do is cost you a lot of money. We've kept our price low so you can manage your budget as easily as your data.

Now Only \$19.95!

Order now by calling our toll free number or mail the coupon to:

Mix Software
1132 Commerce Drive
Richardson, TX 75081

1-800-333-0330

60 Day Money Back Guarantee

Not Copy Protected ■ Royalty Free

For technical support, please call:

1-214-783-6001



Order Coupon

Name _____
Street _____
City _____
State _____ Zip _____
Telephone _____
Paying By Money Order Check
 Visa MC AX Disc.
Card# _____
Exp. Date _____
Disk Size _____ 5 1/4" _____ 3 1/2"

Qty.	Product	Price	Subtotal
_____	C/Database Toolchest.....	\$19.95	_____
_____	C/Database Library Source..	\$10.00	_____
_____	B+tree & ISAM library source code	_____	_____
_____	Add Shipping (\$5 USA, \$20 Foreign).....	_____	_____
_____	Texas Residents Add 8% Sales Tax.....	_____	_____
_____	Total Amount of Your Order.....	_____	B

reason for the i-node's link field: It's a counter that tallies the number of alternate references to the i-node. This lets you provide access to one of your files (or subdirectories) to another user without giving that user access to all your on-line data.

For example, if you've created a file named BOB and you want a friend to have access to it, you can create an entry in your friend's home directory with the name FRANK and an i-node number that is the same as BOB's. The associated i-node's link field would now show a count of 2. If you delete BOB, the link field count drops to 1, but your friend still has access to the file's contents through FRANK. Only when your friend deletes FRANK is the complete file removed.

Keeping track of the file's data is managed by a clever scheme. Each i-node holds a set of 13 pointers. The first 10 pointers are direct pointers; they contain the block numbers of the file's first 10 data blocks. The next pointer field is a single-indirect pointer; it holds the number of a block of pointers that points to the actual data blocks. Following the single-indirect pointer is the double-indirect pointer, which points to a block of pointers, each of whose entries points to a block of pointers that points to the data (gasp). Next comes the triple-indirect pointer, and, before I get tongue-tied describing it, I'll refer you to figure 2.

The Unix design bears a remarkable resemblance to the arrangement used by ProDOS, where a file begins as a sapling file (using only a direct pointer), and as it grows, the direct pointer becomes an indirect pointer and then a double-indirect pointer.

On the DSI-32 system, file pointers are 3 bytes each in the i-node and 4 bytes each in the disk pointer blocks. Since a disk block is 1K byte, each pointer block can hold up to 256 entries. So, a file can hold up to 17 billion characters—provided you can find a disk large enough and the system administration permissions allow you to make a file that big.

Unix doesn't use a bit map to keep track of unused blocks (as Apple DOS 3.3 and ProDOS did). When a file-system is created, Unix builds a linked list of blocks, each member of which holds a table of free block numbers. The first member is kept in the superblock, along with a pointer to the next member. As new blocks are needed, their numbers are retrieved from the table kept in the first member. When this table is exhausted, the system follows the link to the second member of the chain and copies its contents into the superblock, along with a pointer to the third member of the chain (so Unix will know where to go when the second member's table is empty).

Notice that the arrangement favors small files. Data toward the front of a file is accessed most rapidly. This encourages users to keep programs small and atomic so they will load faster.

It's also significant that designers of Unix broke the directory structure into two parts. When you give Unix a filename to locate, the operating system can scan the current directory rapidly since all it has to sift through are entries consisting of names and i-node numbers. All the extraneous baggage that Unix isn't concerned with during a file search is over in the i-node. Once Unix locates your file, then it dips into the i-node to

determine such things as access permissions.

Macintosh

Back when the Macintosh first came out, the file-system portion of the operating system was the infamous Macintosh File System. MFS was a "flat" directory scheme that—through some clever programming—created the illusion of a hierarchical directory. (You may remember that, when you called up a dialog box under MFS, you got a list of every file on the disk.) MFS has been superseded by the HFS, a true multidirectory file system. I'll restrict the discussion here to the HFS; if you are interested in MFS, I suggest that you consult *Inside Macintosh*.

On the Macintosh, "allocation block" again means the minimum storage quantity. Typically, an allocation block is 512 bytes, but, as with the other operating systems I've discussed, HFS does carry provisions for handling allocation blocks of other sizes.

The first two allocation blocks on an HFS volume (the Mac equivalent of a file-system) are given over to start-up data that contains information like the number of files that can be opened simultaneously, the initial size of the system heap, and so on. The third allocation block (offset 2) holds data describing the HFS volume. In it you'll find items like the number of allocation blocks in the volume, the start of the volume bit map, the volume's name, and the number of directories and files on the volume. Table 3 highlights some of the more important information.

Recall that a physical sector is the absolute minimum amount that can be allocated to a file (without fancy and time-consuming manipulation that I won't go into here). The allocation block—which is the minimum amount by which a file grows—is a multiple of physical sectors; it was created to strike a balance between access speed and wasted bytes.

HFS has taken the "allocation block" idea a step further with the use of *clump size*. HFS defines the clump size as a multiple of allocation blocks, and a file grows by clump-size leaps. You can assign different clump sizes to different files. So if you've got a file for which rapid access is a must, you can minimize fragmentation of the file by giving it a large clump size. Of course, this presumes that your disk has enough free space to allocate large contiguous regions of allocation blocks.

The actual directory is maintained in a B*-tree structure, which is an elaboration of the B-tree structure that I de-

Table 2: *i-node format for the DSI-32 Unix System V. The user and group IDs serve to control access to the file. For example, if the proper bits are set in the mode field, anyone with the same group as the owner's group ID can read, write, or execute the file.*

Byte offset	Description
0	File mode (word). This field is actually a series of bit flags that indicate (among other things) the entry's read, write, and execute permissions, whether the entry is a directory, and whether the entry defines the driver for a physical device.
2	Number of links (word).
4	Owner's user ID (word).
6	Owner's group ID (word).
8	File size in bytes (doubleword).
12	File pointers—set of 13 (3 bytes each).
51	Unused.
52	Time and date that the entry was last accessed (doubleword).
56	Time and date that the entry was last modified (doubleword).
60	Time and date that the file was created (doubleword).

scribed in my "Trees 'n Keys" series beginning in the January issue. The HFS B*-tree differs from what I presented there in four ways:

1. Keys may be duplicated in the file; specifically, keys that exist

in nonleaf nodes will also appear in leaf nodes.

2. Nonleaf nodes do not carry pointers to data; they carry only pointers to leaf nodes. Furthermore, there is only one pointer per key on each node.

3. Leaf nodes do not contain data pointers—they contain the data itself.

4. Leaf nodes are cross-connected with forward- and backward-link pointers. This means that, once on a

continued

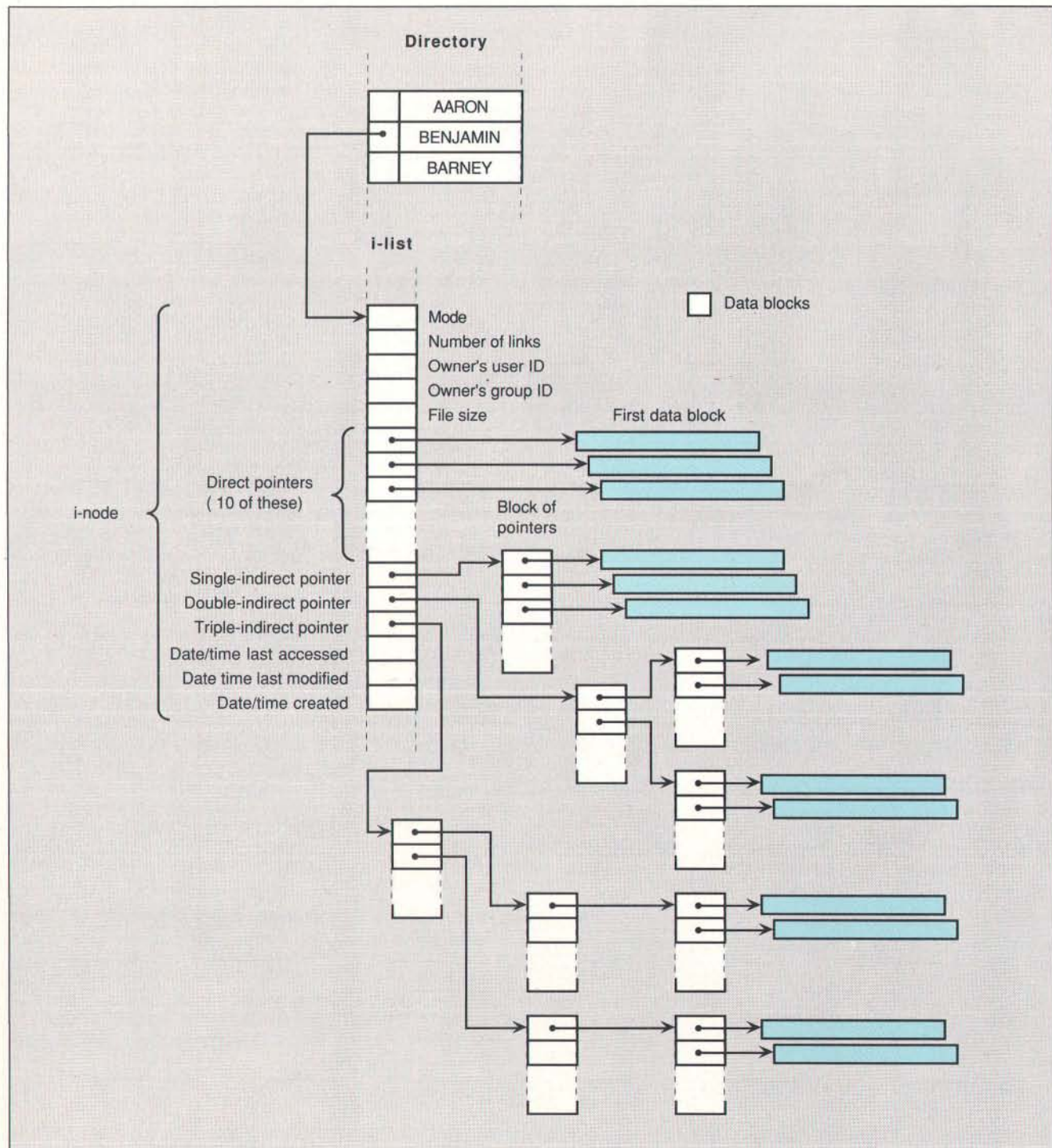

Figure 2: Finding the file **BENJAMIN** on the Unix system consists of searching the directory for the filename and using the associated **i-node** number to retrieve the physical location from the **i-list** structure.

SUBSCRIPTION PROBLEMS?



*We want
to help!*

If you have a problem with your BYTE subscription, write us with the details. We'll do our best to set it right. But we must have the name, address, and zip of the subscription (new and old address, if it's a change of address). If the problem involves a payment, be sure to include copies of the credit card statement, or front and back of cancelled checks. Include a "business hours" phone number if possible.

BYTE MAGAZINE

ATTN: SUBSCRIBER SERVICE
P.O. Box 555
HIGHTSTOWN, NJ 08520

leaf node, you can access all other leaf nodes in linear fashion.

You will see how the use of this elaborate structure (rather than the linked lists of Unix) solves some problems created by the clump-size idea and speeds up file access in very large collections of files. (Figure 3 shows a portion of a sample B*-tree structure as it might appear on a Macintosh HFS.)

Data in the volume information block points to a header record for the start of the catalog B*-tree. This header record contains parametric information for the catalog tree, such as where its root is and what blocks allocated to the tree are used or empty (the free and used blocks are kept track of by a bit map). The actual catalog B*-tree follows this header block. Once the system locates the B*-tree's root record, it can rapidly locate the information it needs for any file or directory in the system.

Each leaf entry in the HFS catalog tree can contain file, directory, or thread information that ties the subdirectory entry back to the location of its parents. Table 4 shows some of the more important fields for file, directory, and thread entries. (If you want the complete layout, see *Inside Macintosh*, vol. IV.)

To find the contents of a file, you have to look in the file entry's extent record. (Keep in mind that, on a Macintosh, each file can have two distinct components: a data fork—the standard data—and a resource fork.)

The resource fork holds objects (called *resources*) that can be anything from a program to the binary data that describes a color palette associated with the data fork. The system associates an extent record with each fork. (For the purposes of this discussion, you can assume that the file-system treats each fork equally.)

An extent record is a three-element

continued

Table 3: Some of the more important locations in the HFS volume information block (for a complete description, see *Inside Macintosh*, vol. IV).

Byte offset	Description
2	Date and time the volume was initialized (doubleword).
6	Date and time the volume was last modified (doubleword).
12	Number of files in the directory (word).
14	First block number of the volume bit map (word).
18	Number of allocation blocks on the volume (word).
20	Number of bytes per allocation block (doubleword).
24	Default clump size (doubleword).
30	Next unused directory or file ID (doubleword).
34	Number of unused allocation blocks (word).
36	Volume name; first byte is byte count.
64	Date and time that the volume was last backed up (doubleword).
82	Number of directories in root.
134	Extent record for extents tree (6 words).
150	Extent record for catalog tree (6 words).

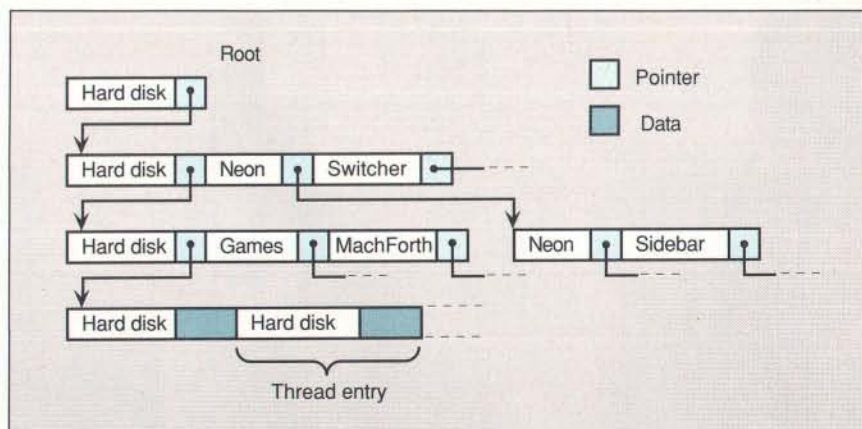

Figure 3: A portion of a Macintosh HFS catalog B*-tree. Once the system locates the root, it can rapidly locate the information for any file or directory.

TWO POWERFUL

TWO ATs on ONE card!

The QL 2286 board features TWO 80286 AT business/engineering workstations on ONE AT add-in card. Plug one or more QL 2286s into your Compaq or IBM AT's bus and create an instant network!

TWICE THE POWER FOR HALF THE PRICE!

QL 2286 features TWO 80286 processors with full EGA/CGA color support and up to TWO MB RAM per user, for about the price of ONE standalone AT. CAD/CAM, word processors, spreadsheets and thousands of Novell multiuser applications operate with lightning speed.

JUST PLUG IT IN!

Plug the QL 2286 into your fileserver's bus, connect a low profile, noiseless peripheral box to the board, attach your monitor, printer and mouse, load NetWare 286 or ELS (or Network-OS), and your installation is complete! No need for hubs, controllers, transceivers or complicated wiring schemes.

ULTIMATE NETWORK SPEED!

Network transfer is at AT bus speeds — that's as fast as you can go — which makes QL 2286 ideal for processing disk intensive database applications. Data travels much faster on the bus than on controller based topologies that require inefficient protocols, serial data paths and expensive controllers.

NETWORKING AT ITS BEST!

QL 2286 boasts an unsurpassed state of the art design that allows you to maximize performance and minimize cost.

QL 2286 supports TWO independent users

Each user has:

- 80286 AT processor
- 80287 math coprocessor (optional)
- 1 MB RAM (with expansion to 2 MB)
- EGA/CGA/Hercules video card
- Keyboard, Monitor, and Mouse or printer support
- COM 1 Port
- COM 2 Port (optional)
- Parallel Port (optional)
- Multisync color monitor support



Put QL 2286 in your LAN plan and be TWO POWERFUL TOO!

Call 1-800-648-2130 or (702) 883-7611 to order.

Compaq 386 is a trademark of Compaq, Inc.
IBM AT is a trademark of International Business Machines Corporation.
Novell NetWare is a trademark of Novell, Inc.
CBIS Network-OS is a trademark of CBIS, Inc.

Made in the U.S.A.

CUBIX
CORPORATION

Corporate Offices • 2800 Lockheed Way, Carson City, Nevada 89706 • Tel (702) 883-7611 • Fax (702) 882-2407

Circle 319 on Reader Service Card

JUNE 1989 • BYTE 333

Computers For The Blind

Talking computers give blind and visually impaired people access to electronic information. The question is how and how much?

The answers can be found in "The Second Beginner's Guide to Personal Computers for the Blind and Visually Impaired" published by the National Braille Press. This comprehensive book contains a Buyer's Guide to talking microcomputers and large print display processors. More importantly it includes reviews, written by blind users, of software that works with speech.

This invaluable resource book offers details on training programs in computer applications for the blind, and other useful information on how to buy and use special equipment.

Send orders to:
National Braille Press Inc.
88 St. Stephen Street
Boston, MA 02115
(617) 266-6160

\$12.95 for braille or cassette, \$14.95 for print. (\$3 extra for UPS shipping)
NBP is a nonprofit braille printing and publishing house.

structure; each element contains a block number and a block count. Each number refers to a "starting" allocation block on the disk, and each count refers to the number of contiguous allocation blocks (beginning with the starting block) that have been given to the file.

When you create a file under HFS, the system will attempt to allocate contiguous blocks to the file so that it uses only the first element of the extent record to point to the file's contents. Of course, as you close the file, then reopen it and add to it, then close it again, and so on, the system cannot continue assigning contiguous blocks to the file; it must use the other two elements of the extent record to keep track of the fragmenting file. If you open, write, and close the file enough times with intervening file operations for other files, you will require more than three records.

When these three extent records are used up and the file grows by a noncontiguous block, the HFS has yet another B*-tree—called the "extents tree"—on hand in which the system records the file's additional extents. The format of an entry in the extents tree is shown in table 5; each entry contains another three-element extent record.

Take, for example, a file named BOB whose data fork contains 100 allocation blocks; all three extent-record elements in the file's catalog tree entry are used up, and you add another block to the file. What happens? HFS locates a new allocation block and records an entry in the extents tree whose key says, "I hold the information to the data fork of BOB starting with allocation block 101."

Thus, when the system receives a request for BOB's block 101 and discovers

continued

Table 4: Important fields in the Macintosh HFS (a) file entry, (b) directory entry, and (c) thread entry. A thread entry always appears adjacent to a directory entry and points to that directory's father directory.

(a)

Byte offset	Description
2	Flags (byte). Bit 0 is set to 1 if the file is locked.
20	File number (doubleword). This unique number is assigned by the system when the file is created.
26	Data fork's logical end of file (doubleword).
30	Data fork's physical end of file (doubleword). This entry counts any unused bytes at the end of the file's last allocation block.
36	Resource fork's logical end of file (doubleword).
40	Resource fork's physical end of file (doubleword).
44	File's creation date/time (doubleword).
48	File's last modification date/time (doubleword).
52	File's last backup date/time (doubleword).
72	File's clump size (word).
74	Data fork's first extent record (6 words).
86	Resource fork's first extent record (6 words).

(b)

Byte offset	Description
0	Reserved (4 bytes).
4	Number of entries in this directory; includes files and subdirectories (word).
6	Directory ID; this unique number is assigned by the system when the directory is created (doubleword).
10	Directory's creation date/time (doubleword).
14	Directory's last modification date/time (doubleword).
18	Directory's last backup date/time (doubleword).

(c)

Byte offset	Description
0	Reserved (10 bytes).
10	ID of parent directory (longword).
14	Name of associated directory (length depends on the length of the name).

There are more impressive transfer systems. But not on this planet.

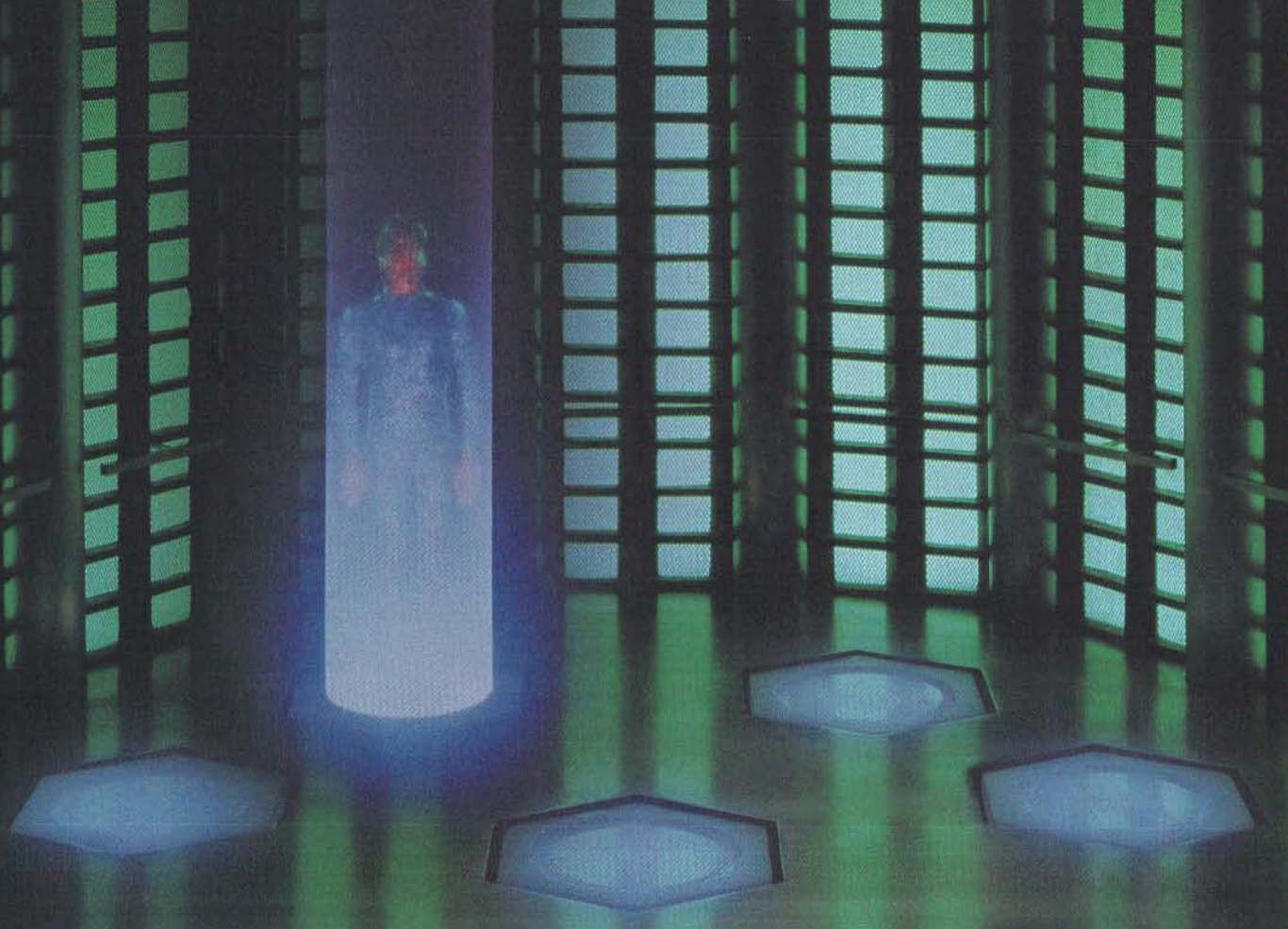

Now you can boldly go where no IBM compatible laptop to desktop file transfer system has gone before.

With FastLynx, the new file transfer system from the developers of the highly acclaimed Fastwire II. FastLynx conveniently and accurately copies files, directories, and complete disks at warp speed (up to more than 500,000 baud in parallel mode or 200,000 baud in serial mode).

Discover FastLynx and our new FastLock file protection system at a special introductory price. Call 1-800-852-RUPP for your nearest dealer.

What's more, FastLynx offers a simple point-and-shoot split screen mode, a form mode to create routine macros, and a command mode to write batch files and execute advanced commands.

No matter what planet you're from, FastLynx is easy to use. Just connect the cable, load the software, and you're ready to go. A convenient upload feature even transfers FastLynx to remote systems without the use of diskettes.

FastLynx. There's not a more impressive transfer system in the world. That is, this world.

FastLynx, Fastwire II, and FastLock are trademarks of the Rupp Corporation. IBM is a registered trademark of International Business Machines Corporation.



**The file transfer system
that really moves.**

that only the first 100 blocks are recorded in BOB's catalog entry, the system does a rapid search in the extents B*-tree for the entry I've just described. Figure 4 should give you a picture of how this works. Without using a structure like the B*-tree, there would be a terrible

degradation in seek operations for files with extents because, unlike Unix and MS-DOS, record size is determined by a variable (the clump size).

The HFS directory structure is by far the most complex of the systems that I've looked at in this series. It's also poten-

tially the most powerful. If you can manage to put files on your HFS so that no fragmentation occurs, then the system can theoretically keep track of each file using no more than one extent record in the file's catalog entry. Each of the other directory structures that I've presented so far must use multiple pointers to handle a file larger than about 10K bytes, even if the contents of that file have been stored contiguously on the disk. This means that an HFS volume responds wonderfully to a good defragmentation program.

For example, I use Disk Express about once every six months on my Mac Plus's 20-megabyte hard disk. When I was digging around on the volume to write this column, I found only four entries in my extents file, even though I've used up over 16 megabytes of space. This means that practically all of my files' contents are accessed via the extent records in the catalog. Things were more contiguous than I imagined.

Last Entry

It's interesting to see how software engineers have solved a problem that occurs on all computer systems with disk drives. It's also interesting how similar some of the components of directory structures are, even for vastly dissimilar operating systems.

Directory structures are growing more complex in order to carry the burden of larger hard disk drives. Some structures can run their file-systems into trouble as the storage media get bigger and faster and as systems that were once single-user become part of a network.

I wrote this column on an MS-DOS machine with two hard disk drives and thousands of files. You may have a computer like mine, or a Mac or an Apple II, or even a Unix machine. Like me, you probably have your favorite programs and your most important data files on the hard disk, and you're satisfied with the speed with which your computer calls up your data. Maybe you've been lucky and your system has never lost a file. But if it ever does, now you'll know where to go to look for it. ■

Rick Grehan is the director of the BYTE Lab. He has a B.S. in physics and applied mathematics and an M.S. in computer science/mathematics from Memphis State University. He can be reached on BIX as "rick_g."

Your questions and comments are welcome. Write to: Editor, BYTE, One Phoenix Mill Lane, Peterborough, NH 03458.

Table 5: An entry in the HFS extents tree. The first 8 bytes of the entry make up the key; the rest is the entry's data.

Byte offset	Description
0	Key length (byte).
1	0 for data fork, 255 for resource fork (byte).
2	File number (doubleword).
6	Allocation block number within file defined by this extent record (word).
8	Extent's first allocation block (word).
10	Number of allocation blocks in this extent (word).
12	Two more extent elements (4 words total).

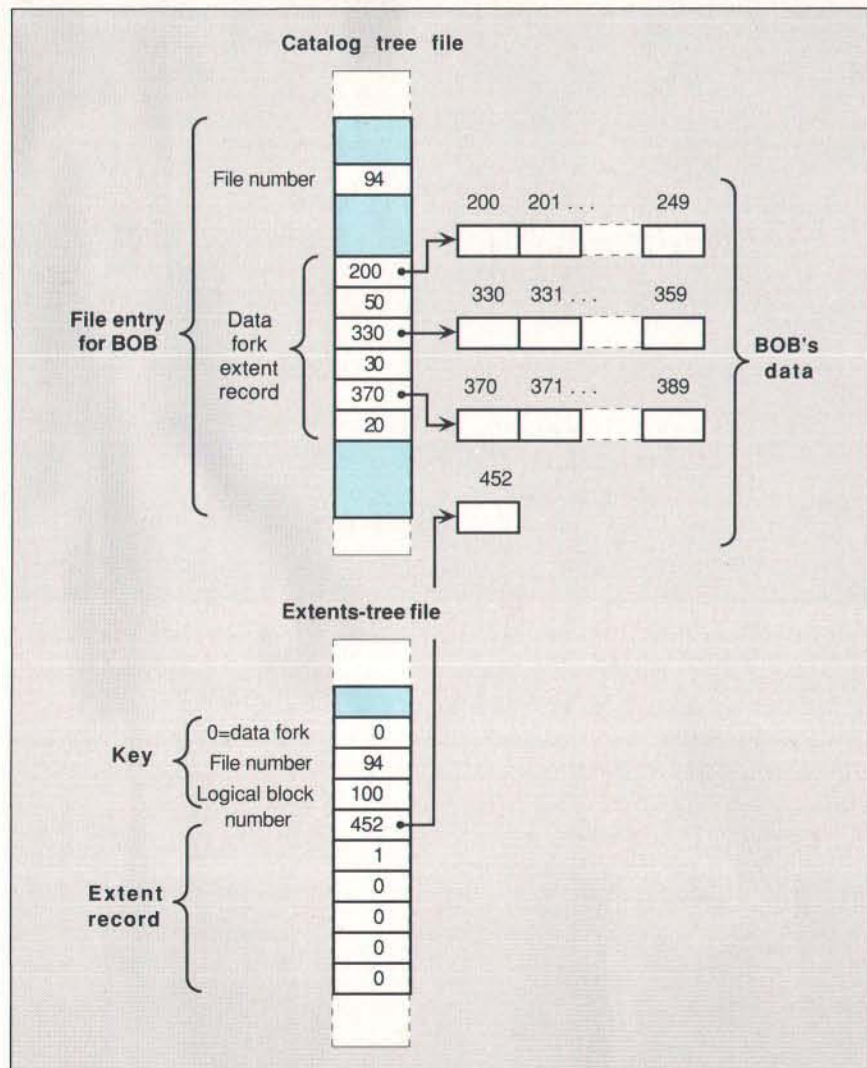

Figure 4: The file BOB is stored on the HFS volume. The file's data fork has become so fragmented that the system has had to create an extents-tree entry.

PRODUCT SHOWCASE

■ BUYER'S MART

■ BYTE BITS

■ PRODUCT SPOTS

■ MICRO PRODUCT CENTER



THE BUYER'S MART

A Directory of Products and Services

THE BUYER'S MART is a monthly advertising section which enables readers to easily locate suppliers by product category. As a unique feature, each BUYER'S MART ad includes a Reader Service number to assist interested readers in requesting information from participating advertisers.

RATES: 1x—\$525 3x—\$500 6x—\$475 12x—\$425
Prepayment must accompany each insertion. VISA/MC Accepted.

AD FORMAT: Each ad will be designed and typeset by BYTE. Advertisers must

furnish typewritten copy. Ads can include headline (23 characters maximum), descriptive text (250 characters is recommended, but up to 350 characters can be accommodated), plus company name, address and telephone number. Do not send logos or camera-ready artwork.

DEADLINE: Ad copy is due approximately 2 months prior to issue date. For example: November issue closes on September 8. Send your copy and payment to THE BUYER'S MART, BYTE Magazine, 1 Phoenix Mill Lane, Peterborough, NH 03458. For more information call Brian Higgins at 603-924-3754.

ACCESSORIES

CUT RIBBON COSTS!

Re-ink your printer ribbons quickly and easily. Do all cartridge ribbons with just one inker! For crisp, black professional print since 1982. You can choose from 3 models: Manual E-Zee Inker — \$39.50
Electric E-Zee Inker — \$89.50
Ink Master (Electric) — \$189.00

1000's of satisfied users in 5 years. Money-back guarantee.

BORG INDUSTRIES

525 MAIN ST., JANESVILLE, IA 50647

1-800-553-2404 In IOWA 319-987-2976

Inquiry 576.

ACCESSORIES

COMPUTER CLOCK \$39

Clock/calendar for PS/2 & PC/XT compatibles, automatically enters time & date without wasting valuable I/O slot. Inserts transparently between a 28 pin ROM & its socket. Even works in BIOS or HD controller ROM. 10 yr. lithium battery. Software included. 30 day money-back guarantee. All orders shipped within 1 business day.

Time-Master part #1111TM \$39.00 + \$2.50 S&H

800 432-9174 (24 hr.)

Talus Engineering, Inc.

Inquiry 581.

BAR CODE

BAR CODE READERS

For PC, XT, AT, & PS/2, all clones, and any RS-232 terminal. Acts like 2nd keyboard, bar codes read as keyed data. With steel wand—\$399. Works with DOS, Xenix, Novell, Alloy, -ALL software. Lasers, magstripe, & slot badge readers. One year warranty. 30 day \$ back. Direct from USA manufacturer.

Worthington Data Solutions

417-A Ingalls St., Santa Cruz, CA 95060

(800) 345-4220 In CA: (408) 458-9938

COMPANION AND EXTENDER

Place a keyboard and monitor up to 600' from your CPU with EXTENDER and COMPANION products. Keep a second Keyboard/Monitor at the CPU with COMPANION. Supports MDA, CGA, EGA, VGA, PS2. Uses single 3/8" cable.

Prices start at \$149.00 for EXTENDER and \$219.00 for COMPANION 25 ft. unit complete.

CYBEX CORPORATION

2800-H Bob Wallace, Huntsville, AL 35805
205-534-0011 International Fax # 205-837-9212

Inquiry 577.

ARTIFICIAL INTELLIGENCE

NATURAL LANGUAGE C LIBRARY

Increase your market share! Use JAKE to add a natural language front end to your application. JAKE translates English queries and commands into C function calls and data structures. JAKE offers context-sensitive semantic processing; interfaces easily; <64K mem.

JAKE \$495. INTERACTIVE DEMO \$10

ENGLISH KNOWLEDGE SYSTEMS, INC.

5525 Scotts Valley Dr. #22, Scotts Valley, CA 95066

(408) 438-6922

Inquiry 582.

PRINT BAR CODES/BIG TEXT FROM YOUR PROGRAM

Add bar codes and big graphics text to your program. Print from ANY MS-DOS language. Bar codes: UPC, EAN, 2 of 5, MSI, Code 39. Epson, Oki, IBM dot matrix text up to 1/2". LaserJet up to 2". Font cartridges not required. \$179-\$239. 30 day \$ back.

Worthington Data Solutions

417-A Ingalls St., Santa Cruz, CA 95060

(800) 345-4220 In CA: (408) 458-9938

RIBBONS • RIBBONS • RIBBONS

Fast, Professional, Friendly Service. Over 1,100 Printer & Typewriter Ribbons Available. One Call For All Your Ribbon Needs!

—THE RIBBON SOURCE—

SATISFACTION GUARANTEED!

San Diego (800) 259-8800 So. Cal. (800) 453-6688 U.S. (800) 354-7744

Inquiry 578.

NanoLISP \$99.99

An MS-DOS Common LISP interpreter that supports most Common LISP operations and strictly adheres to the standard. Numerous advanced and extra features, excellent debugging facilities, sample AI programs, fully-indexed manual, free technical support.

Microcomputer Systems Consultants

P.O. Box 6646, Santa Barbara, CA 93160

(805) 967-2270

Inquiry 583.

PORTABLE READER

Battery operated, handheld reader with 64K static RAM, 2x16 LCD display, 32-key keyboard, RealTime-Clock. Wand or laser scanner. Program prompts and data checking thru its own keyboard. Easy data transfer by RS-232 port or PC, PS/2 keyboard. Direct from USA manufacturer. 30 day \$ back.

Worthington Data Solutions

417-A Ingalls St., Santa Cruz, CA 95060

(800) 345-4220 In CA: (408) 458-9938

Inquiry 584.

FREE CATALOG

A complete source for computer supplies at low prices. Fast Service! Call, write or circle inquiry card for a FREE CATALOG. Use your VISA, MC or OOD to order the following bulk diskettes

5.25" DS/DD (Min 50) 26¢
5.25" DS/HD (Min 50) 62¢
3.5" DS/DD (Min 30) 99¢

GAAN COMPUTER SUPPLIES

186 B East Sunnyvale Ave., Campbell, CA 95008
(800) 523-1238, In Calif. (408) 370-6747

Inquiry 579.

muLISP™ 87 for MS-DOS

Fast, compact, efficient LISP programming environment. muLISP programs run 2 to 3 times faster & take 1/2 to 1/3 the space of other LISPs. 450 Common LISP functions, multi-window editing & debugging, flavors, graphics primitives, lessons & help, demo programs, comprehensive manual.

Soft Warehouse, Inc.

3615 Harding Ave., Suite 505, Honolulu, HI 96816

(808) 734-5801

Inquiry 583.

YOUR SALES MESSAGE

about the special computer product or service that you provide belongs in print.

THE BUYER'S MART

can help you reach computer professionals and produce valuable inquiries for your company!

Call Brian Higgins for more information

603-924-3754

Inquiry 584.

BAR CODE

PRINT BAR CODES, BIG TEXT, LOGOS

On EPSON, IBM, OKI dot matrix or LaserJet. Design any format/size on ONE easy screen. 1-120 fields/label. 13 text sizes to 1" — readable at 50 ft. AIAG, MIL-STD, 2 of 5, 128, UPC/EAN, Code 39. File Input, FAST—\$279. Logos, Product Symbols. Other menu-driven bar code programs from \$49. 30 day \$ back.

Worthington Data Solutions

417-A Ingalls St., Santa Cruz, CA 95060

(800) 345-4220 In CA: (408) 458-9938

BAR CODE SOLUTIONS

Bar coding is so easy with our complete line of readers. Our PC-Wand readers emulate your PC keyboard or ASCII terminal, and are carried around taking inventory, entering road sales and clocking time. Our bar code label printing software packages work with DOS and most matrix or laser printers. We also sell pre-printed labels. Our hardware can work with nearly every computer in the world.

International Technologies & Systems Corp.

635-C North Berry St., Brea, CA 92621

(714) 990-1880 FAX: 714 990-2503 TLX 6502824734 MCI

Inquiry 580.

BAR CODE

BAR CODE SOFTWARE SOLUTIONS

ISD has software solutions that allow you to use bar codes for most anything. Like identifying products. Labeling packages. Or even managing assets and paperwork. You'll be able to speed and simplify data collection. Track products dock-to-stock. Streamline inventory control. And more.

Integrated Software Design, Inc.

171 Forbes Blvd., Mansfield, MA 02048
 TEL: (508) 339-4928 FAX: (508) 339-2257

© 1989 Integrated Software Design, Inc.

Inquiry 586.

WHEN EASE-OF-USE COUNTS

Reading bar codes should be as easy as a "quick flick of the wrist." But many bar code readers require you to flick and flick and Flick and FLICK until the bar code label is finally read. PERCON designed bar code readers that really are as easy as a "quick flick of the wrist."

PERCON

2190 W. 11th Ave., Eugene, OR 97402

Phone: (800) 873-7266 FAX: (503) 344-1399

PERCON: THE BAR CODE SPECIALISTS

If you have questions about bar code technology, it's nice to know an experienced, friendly bar code specialist is only a phone call away. Want to know where to start or where to find hard-to-find bar code accessories? Call PERCON for answers

PERCON

2190 W. 11th Ave., Eugene, OR 97402

Phone: (800) 873-7266 FAX: (503) 344-1399

5 YR. WARRANTY AT PERCON

PERCON decoders are now covered by a five year limited warranty. That means you won't spend one cent replacing your PERCON bar code decoder for five full years. That's reliability you can count on!

PERCON

2190 W. 11th Ave., Eugene, OR 97402

Phone: (800) 873-7266 FAX: (503) 344-1399

PC BAR CODE SPECIALISTS

Bar code readers designed for fast, reliable, cost effective data entry. Looks just like keyboard data! Choose from stainless steel wand or laser interface. Also, powerful Bar Code and Text printing software. Great warranty. Dealer inquiries welcome.

Seagull Scientific Systems

15127 N.E. 24th, Suite 333, Redmond, WA 98052
 206-451-8966

BAR CODING SOURCE CODE

UPC, EAN, CODE 39, 2 of 5, and Codabar. Ready to run programs with source codes. Toolkit for 'C' programmers. Do barcodes from your own programs. Supports HP LJ and Epson printers. Includes disk, manual, and symbology documentation. No royalties. 30-day money-back guarantee.

SymbCG — \$79.00 Complete

Symbologic

17019 Jeanette Ave., P.O. Box 4749B, Cerritos, CA 90703
 (CA res. add \$4.81 tax) (213) 926-2823

Inquiry 587.

BAR CODE

DATA INPUT DEVICES

Bar Code, Magnetic Stripe Readers & SmartCard Encoder/Reader for microcomputers & terminals, including IBM PS/2 & others, DEC, Macintosh, AT&T, CT, Wyse, Wang. All readers connect on the keyboard cable & are transparent to all software. UPC & 39 print programs, magnetic encoders, & portable readers are also available.

TPS Electronics

4047 Transport, Palo Alto, CA 94303
 415-856-6833 Telex 371-9097 TPS PLA
 FAX: 415-856-3843

Inquiry 588.

VARIANT MICROSYSTEMS BAR CODE READERS DELIVER

WAND/LASER/MAGNETIC CARD CONNECTIVITY

- Keyboard wedges (Internal/External) for IBM PC/XT/AT, PS/2 and portables.
- RS232C wedges for WYSE, Link, Kimtron terminals
- Bar code and label printing software
- Full two-year warranty
- 30-Day Money-Back Guarantee
- Extensive VAR/Dealer Discounts

3140 De La Cruz Blvd., Suite 200/Santa Clara, CA 95054/(408) 980-1880
 FAX: 415-623-1372

Inquiry 589.

CAD/CAM

PHOTO PLOTTING

from your Smartwork Edit file or any RS-274 Gerber Photo Plot file. Raster type Photoplotting supplied on .007" thick Kodak Ultraline film. Plot data accepted by modem, 5 1/4", 3 1/2" MS-DOS format disks or 9 track mag tape. Gerber plot file 8"x10" plots start from \$15.00.

Call for details.

KEPRO CIRCUIT SYSTEMS

Fenton, MO

1-800-325-3878 / 1-314-343-1630 in MO.

Inquiry 590.

CASE

FINITE STATE PROGRAM COMPILERS

State programs develop quicker, run faster and use less memory than sequential programs. A few keystrokes can replace hundreds of instructions. The Compeditor, a CASE software development tool, forms source state programs in: Ada, BASIC, C, FORTRAN and Pascal. FOR IBM DOS.

Price \$200 per lang. (With Primer and Debugger)

Sampler \$50.00 (With all manuals & credit)

AYECO 5025 Nassau Circle, Orlando
 INCORPORATED FL 32808 (407) 295-0930

Inquiry 591.

CD-ROM

CD-ROM BUILDERS OMNIBUS

Provides the complete computer system and software prerequisites needed for a fast, productive DOS-based CD-ROM development environment. AMI 80386 25MHz, 4 MB RAM; 338MB Wren; Hitachi CDR-3500 w/audiod; 800 MB WORM, AUM-1381A VGA. Other high performance, capacity, and reliability developer platforms/file servers also available. Send for catalog.

5G Corporation

4131 Spicewood Springs Road A-4, Austin TX 78759
 800/333-4131 FAX 512/345-9575

Inquiry 592.

CD-ROM Drives & Titles

Largest selection for PC & Mac.
 Microsoft Programmers Library & Drive \$995
 Computer Library \$695 • Public Domain S/W \$99.

Drives from \$699. Hundreds of titles from \$29.
 MC/VISA/AMEX, Money-back Guarantee.
 Call or write for free 100-page catalog.

Get it all from "The Bureau"

Bureau of Electronic Publishing

121 Norwood Ave., Upper Montclair, NJ 07043
 (201) 746-3031

Inquiry 593.

CD-ROM

Food/Analyst CD-ROM

Analyze foods, meals, and recipes for any number of persons based on the complete USDA food nutrient database. 4700+ foods, 80+ nutrients. See graphs, printed reports, summaries. Other titles and CD-ROM publishing services available.

Hopkins Technology

CD-ROM Publisher
 421 Hazel Lane, Suite 104
 Hopkins, MN 55343
 (612) 931-9376 Compuserve 74017,614

Inquiry 594.

CD-ROM Developer's Lab

Multimedia production resource for Mac & PC developers & managers. Proven design, management, data prep, programming, premastering, and manufacturing techniques & specs from 18 leading companies. Demos of off-the-shelf tools for imaging, audio, animation (Mac). Real applications using Media-Mixer source tools. CD-ROM XA. PC or Mac \$ 795; Transportable \$845. Visa or MasterCard.

Software Mart, Inc.

4131 Spicewood Springs Road I-3, Austin TX 78759
 512-346-7887

Inquiry 595.

COMPUTER INSURANCE

INSURES YOUR COMPUTER

SAFWARE provides full replacement of hardware, media and purchased software. As little as \$39 a year provides comprehensive coverage. Blanket coverage; no list of equipment needed. One call does it all. Call 8 am-10 pm ET. (Sat. 9 to 5)

TOLL FREE 1-800-848-3469

(Local 614-262-0559)

SAFWARE, The Insurance Agency Inc.

Inquiry 596.

CROSS ASSEMBLERS

CROSS ASSEMBLERS

Universal Linker, Librarian
 Targets for 36 Microprocessors
 Hosts: PC/MS DOS, micro VAX, VAX 8000
 Developed and supported at:

ENERTEC, INC.

BOX 1312, Lansdale, PA 19446
 Tel: 215-362-0966 Fax: 215-362-2404

Inquiry 597.

Professional Series

PseudoCode releases its PseudoSam professional Series of cross assemblers. Most popular processors. Macros, Conditional Assembly, and Include Files. Virtually unlimited size. For IBM PC's, MS-DOS 2.0 or greater. With manual for \$50.00. (MI res. 4% tax). Simulators and disassemblers also available. Shipping \$5, Canada \$10, Foreign \$15. Visa/MC.

KORE INC.

6910 Patterson, Caledonia, MI 49316 616-887-1444
 30-Day satisfaction guaranteed or purchase price refunded.

Inquiry 598.

FANTASTIC SIMULATORS

For the 8048, 8051, 8080, 8085, & Z80 families. Full function simulation including ALL MODES of Interrupts. Built-in disassembler. Better than expensive I.C.E.'s.

CROSS ASSEMBLERS

We support the 8048, 8051, 8080/8085, 8096 & Z80 families. Just \$75 each.

Lear Com Company

2440 Kipling St./Ste. 206, Lakewood, CO 80215
 303-232-2226

Inquiry 599.

THE BUYER'S MART

CROSS ASSEMBLERS

CROSS ASSEMBLERS

Macros, PC Compatible, Relocatable, Conditionals, Fast, Reliable from \$150 also: Disassemblers

EPROM Programmer Board

MICROCOMPUTER TOOLS CO.

Phone (800) 443-0779

In CA (415) 825-4200

912 Hastings Dr., Concord, CA 94518

Inquiry 600.

DATA/DISK CONVERSION

DISK & TAPE CONVERSIONS AUTOMATICALLY

SAVE TIME AND MONEY

Over 1000 formats from Mini, Micro Mainframe, Word Processors, & Typesetters.

TAPE Conversions as low as \$2300 MB

DISK Conversions as low as \$1500 per Disk

Call or write TODAY for a cost saving quotation.

CREATIVE DATA SERVICES

1210 W. Latimer Ave., Campbell, CA 95008
(408) 866-6080

Inquiry 606.

DEMOS/TUTORIALS

INSTANT REPLAY III

Build Demos, Tutorials, Prototypes, Presentations, Music, Timed Keyboard Macros, and Menu Systems. Includes Screen Maker, Keystroke/Time Editor, Program Memorizer, and Animator. Recd *Great Reviews!* Simply the BEST. Not copy protected. No royalties. 60-day satisfaction money back guar. IBM and Compatib. \$149.95 U.S.Chk/Cr. Crd. Demo Diskette \$5.00

NOSTRADAMUS, INC.

P.O. Box 9252

Salt Lake City, Utah 84109 (801) 272-0671

Inquiry 612.

DISASSEMBLERS

SOFT-X-PLORE

See "BYTE's May '88 issue pg. 78". Disassemble 500 kb (*) program at 10,000/min. (*) in any file, ROM/RAM memory up to 80386 instruction set (*). SOFT-X-plore:

* is for MS/DOS 2.0+ systems

* uses 20 algorithms and seven passes (*)

* only \$99.95 plus S&H w/30 day guarantee.

To order call (800) 446-4656 or info (203) 560-0236

Or write: **RJSWANTEK INC.**

178 Brookside Rd., Newington CT 06111

* best on the market MC/VISA accepted

Inquiry 613.

DISK COMPATIBILITY

IBM PC's USE Mac DISKS

MatchMaker lets you plug any Macintosh external floppy drive into an IBM PC. Half size card and software lets you copy to/from, view directory, initialize, or delete files on the Mac diskette. Works with PCs, XT's, AT's, and compatibles. *The easy way to move information!*

\$149.00 Visa/MC/COD/Chk.

Micro Solutions Computer Products

132 W. Lincoln Hwy., DeKalb, IL 60115 815/756-3411

Inquiry 614.

DISK DRIVES

PS/2 DRIVES FOR PC's AT's

CompatiKit/PC \$279

CompatiKit/AT \$219

Build-in floppy controllers—no problem. Supports multiple drives and formats. Lets your computer use IBM PS/2 1.4M diskettes *plus more!* Call for further information or to place an order. *VISA/MC/COD/CHECK.*

Micro Solutions Computer Products

132 W. Lincoln Hwy., DeKalb, IL 60115 815/756-3411

Inquiry 615.

DISK DUPLICATION

SOFTWARE PRODUCTION

- Disk duplication
- All formats
- EVERLOCK copy protection
- Label/sleeve printing
- Full packaging services
- Warehousing
- Drop shipping
- Fulfillment
- 48-hour delivery
- Consultation & guidance

Star-Byte, Inc.

2880 Bergey Rd., Hatfield, PA 19440

215-997-2470 800-243-1515

Inquiry 616.

DUPLICATION SERVICES

SOFTWARE DUPLICATION

- One Stop Shopping
- Custom Packaging
- Copy Protection
- Technical Support
- Drop Shipping
- Fast Turnaround
- Competitive Pricing

SATISFACTION GUARANTEED

800-222-0490 NJ 201-462-7628

MEGAsoft

P.O. Box 710, Freehold, NJ 07728 See our ads on page 322.

Inquiry 617.

680X0 Cross Assemblers

Now, inexpensive quality 680X0 Cross-Assemblers that use your IBM PC or compatible. All versions support up to 32 char labels, INCLUDE files, PATH names, extensive list output, sorted symbol tables, many common directives, printed manuals. Basic versions create S-records. Linking versions include a librarian & linker, create either S-records or relocatable modules linked to create S-records or binary files. Minimum requirements are 320K, DOS 2.XX, & 1-5 1/4" DSDD.

Basic 68000/68010—\$349.95 Basic 68020—\$69.95
Linking 68000/68010—\$89.95 Linking 68020/68881—\$129.95
Linking 68030/68881—\$149.95

Checks, VISA, MC accepted. MN residents +6% sales tax.
No P.O.'s or COD's please.

RAVEN Computer Systems

Box 12116, St. Paul, MN 55112 (612) 636-0365

Inquiry 601.

FROM MACs TO MAINFRAMES. . .

Our 12 conversion systems support over 1000 formats

DISK INTERCHANGE SERVICE COMPANY

2 Park Drive • Westford, MA 01886
(508) 692-0050

Inquiry 607.

6800-Family Development Software

Our C Compilers for the 6800, 6801, 6809, & 68HC11 feature a complete implementation (excluding bit fields) of C as described by K&R and yield 30-70% less code than other compilers. Our Assemblers feature macros and conditional assembly. Linker & Terminal Emulator included.

Wintek Corporation

1801 South St., Lafayette, IN 47904
(800) 742-6809 or (317) 742-8428

Inquiry 602.

THE #1 CHOICE

in disk & tape conversion

for many leading corporations, government agencies, law firms, and companies in every industry—world-wide.

Free test • Satisfaction guaranteed
Call the helpful conversion experts . . .

Graphics Unlimited Inc.

3000 Second St. North, Minneapolis, MN 55411
(612) 588-7571

Inquiry 608.

DATA CONVERSION

MEDIA CONVERSION/DATA TRANSLATION

More than just a straight dump or ASCII transfer!

Word Processing, DBMS, and Spreadsheet data on Disks or Tapes transferred directly into applications running on Mainframes, Minis, Micros, Dedicated Word Processors, Typesetters, and Electronic Publishing systems.

IBM PS/2 & Macintosh supported
#1 in the translation industry!

CompuData Translators, Inc.

3325 Wilshire Blvd., Suite 1202, Los Angeles, CA 90010
(213) 387-4477 1-800-825-8251

Inquiry 603.

IBM PC ↔ to ↔ HP

FILE COPY

IBM PC to HP File Copy allows IBM PCs, PS/2, compatibles to read, write files written by Hewlett Packard Series 70, 80, 200, 300, 1000, 9000's. We offer custom work using our file copy utilities and program translators. Call for estimate, catalog, data sheet.

Oswego Software

507 North Adams St. Fax 312/554-3573
Oswego, Illinois 60543 Telex 858-757

Inquiry 609.

DATA/DISK CONVERSION

Get the Expertise You Need!

Disk/Disk • Tape/Disk • OCR

Over 1,000 formats! 3 1/2", 5 1/4", or 8 inch disks; 9-track mag tape; 10 MB Bernoulli cartridge. Data base and word processor translation. Specialists in Government Security Data. Call for free consultation.

Computer Conversions, Inc.

9580 Black Mtn. Rd., Ste J, San Diego, CA 92126
(619) 693-1697

Inquiry 604.

CONVERSION SERVICES

Convert any 9-track magnetic tape to or from over 1000 formats including 3 1/2", 5 1/4", 8" disk formats & word processors. Disk to disk conversions also available. Call for more info. Introducing OCR Scanning Services.

Pivar Computing Services, Inc.

165 Arlington Hgts. Rd., Dept. #B
Buffalo Grove, IL 60089 (312) 459-6010

Inquiry 610.

DISK CONVERSIONS

Media transfer to or from: IBM, Xerox, DEC, Wang, Lanier, CPT, Micom, NBI, CT, also WP, WS, MS/WRD, DW4, MM, Samna, DEC DX, MAS 11, Xerox-Writer, ASCII.

FREE TEST CONVERSION CONVERSION SPECIALISTS

531 Main St., Ste. 835, El Segundo, CA 90245
(213) 545-6551 (213) 322-6319

Inquiry 605.

LEARN THE ABC'S OF 1-2-3

LEADING EDGE'S New Softvision VCR Training ACCELERATES learning LOTUS 1-2-3. You get: 84-min videotape, workbook and practice disk. Now you're up-to-speed on Lotus 1-2-3. Just \$29.95 + 2.50 P&H. ORDER NOW. Money back if not delighted. All major credit cards. CALL NOW.

LIFE DYNAMICS

6050 Peachtree Pkwy., #240-226, Norcross, GA 30091
(800) 548-9608 M-F 10-6
(800) 548-5782 Ext. 12 ANYTIME

Inquiry 611.

EDUCATION

B.Sc. DEGREE IN PROGRAMMING

The American Institute for Computer Sciences offers an in-depth correspondence course which allows you to earn your Bachelor of Science degree in computer programming at home. Subjects covered are: MS/DOS, BASIC, PASCAL, C, Data File Processing, Data Structures & Operating System Concepts.

AMERICAN INST. FOR COMPUTER SCIENCES

1704-BY 11th Ave. So., Birmingham AL 35205
TOLL FREE 1-800-872-AICS

Inquiry 618.

EDUCATIONAL VIDEOS

EZ-PC : MS-DOS VIDEO COMPUTER TRAINING MADE SIMPLE

- Learn MS-DOS Quick & Easy
- No computer jargon—All terms explained
- No prerequisites—Anyone can learn
- Affordable training in your home

ORDER NOW - \$24.95

Add \$2.00 Shipping VISA-MC-AMEX-Check

VIDEOMATION PRODUCTIONS, INC.

8323 Burwood Park Dr., Spring, Texas 77379
713-251-4224

Inquiry 619.

ENTERTAINMENT

NEMESIS™ Go Master®

Go, a game of strategic elegance, has been a way of life in the Orient for over four thousand years. Many consider Go to be the secret of the Japanese businessman's success. "While chess is a game of war, Go is a game of market share" [President of Nikko Hotels].

"If you are interested in Go, buy this program."

Game of the Month J. Pournelle BYTE 7/87

Toyogo, Inc. The Leader in Computer Go
76 Bedford St. #34Y, Lexington, MA 02173, (617) 861-0488

Inquiry 620.

FLOW CHARTS

Flowchart/State Diagram for Engineers

Draw flowcharts or state diagrams with this MacDraw like program on your IBM PC/AT/PS2 or compatible. All flowchart symbols are prebuilt and can be stretched to any size. Add your own symbols to the symbol library. Ellipses, curves with ending arrowheads, cut/paste, enlarge/reduce, drag, zoom out, undo, etc. Output to most printers, plotters, and desktop publishing software. Complete with Logitech Mouse for \$89. See our larger ad every other month.

Daytron Electronics Inc.

610 S. Sherman #104, Richardson, TX 75081 214-669-2137

Inquiry 621.

FLOW CHARTING II+ HELPS YOU!

Precise flowcharting is fast and simple with Flow Charting II+. Draw, edit and print perfect charts: bold and normal fonts, 26 shapes — 95 sizes; fast entry of arrows, bypasses & connectors; Fast Insert Line; shrink screen displays 200-column chart; 40 column edit screen for detail work, much more!

PATTON & PATTON

81 Great Oaks Blvd., San Jose, CA 95119
1-800-525-0082 Ext. 42 (Outside CA)
408-629-5376 Ext. 42 (CA/Int'l)

See our ad on page 130.

Inquiry 622.

WINDOWS FLOWCHARTER \$79

RFFlow is a drawing tool designed specifically for flowcharts. Easy to learn, easy to use. 75 shapes automatically adjust in size. Move, copy, or delete groups of objects. 7 levels of zoom. Use mouse or keyboard. On-line user's manual. Supports Windows printers, plotters, and fonts. \$5 trial disc. RFFlow requires Microsoft® Windows.

RFF ELECTRONICS

1053 Banyan Court, Loveland, CO 80538
(303) 663-5767

Inquiry 623.

FLOW CHARTS

STRUCTURED FLOW CHART

NSChart creates Nassi-Shneiderman (structured) flowcharts from a simple PDL. Keywords define structures & text strings appear in the chart. Easy to create, even easier to revise! Automatic chart sizing, text centering. Translators from many languages available. For Mac and IBM PC.

SILTRONIX, INC.

P.O. Box 82544, San Diego, CA 92138

1-800-637-4888

Inquiry 624.

FORTRAN TOOLS

Tame Your Fortran Code!

Make your Fortran source more readable, portable, and maintainable.

PRETTY cleans up code: indents, relabels, changes GOTOs to IFTHEN-ELSEs, etc.

OUTLINE graphically highlights IF and DO nesting.

PREP supports conditional compilation, include files.

Plus four more. MS-DOS. All for \$129.

Quibus Enterprises, Inc.

106 N. Draper Ave., Champaign, IL 61821

(217) 356-8876

Inquiry 625.

GRAPHICS

35mm SLIDES—in 24 Hours

We transform your PC-Graphics files into full-color high-resolution, 35mm slides and ship within 24 hours. Harvard, Pixie, Lotus, Freelance, and others supported. Files accepted by modem. Free Federal Express on all orders of 20+ slides. Only \$8 per slide. Call for literature or circle reader service number shown below.

Accent Presentations, Inc.

990 Highland Drive, Ste. 202, P.O. Box 1303, Solana Beach, CA 92075

1-800-222-2592

Inquiry 626.

RAINDROP™

FAST, compact PrtScrM Utility for end users AND developers. Hardcopy as fast as 10 secs. Average binary size - 6 kbyte. 12 video graphic standards. Scale, rotate, colorize and more. "CALL" from user written programs. Complete 9 & 24 pin dot matrix, inkjet, and laserjet library \$39.95+\$3 s/h.

RAINBOW TECHNOLOGIES

8106 St. David Ct., Springfield, VA 22153

(703) 440-0064

Inquiry 627.

HARD DRIVE REPAIR

HARD DRIVE REPAIR

WE WILL REPAIR YOUR HARD DRIVE AT A FRACTION OF THE COST OF REPLACING IT. FAST TURNAROUND!!! CALL FOR DETAILS

H & W micro, Inc.

528-C FOREST PARKWAY
FOREST PARK, GA 30050

(404) 366-1600

Inquiry 628.

HARDWARE

CHIP CHECKER

- 74/54 TTL + CMOS
- 8000 Nat. + Signetics
- 1444000 CMOS
- 9000 TTL
- 14-24 Pin Chips
- 3" + .6" IC widths

Tests/identifies over 650 digital chips with ANY type of output in seconds. Also tests popular RAM chips. IBM compatible version \$259. C128 + C64 version \$159.

DUNE SYSTEMS

2603 Willa Dr., St. Joseph, MI 49085

(616) 983-2352

Inquiry 629.

HARDWARE

Equipment Monitor And Control

Ideal cost effective computer can be used to perform data acquisition and control using a dumb terminal or create data files on a PC. Features 16 chan. A/D, 64 digital I/O lines, 4 timer/counters and 4 serial ports. Options 4 chan. D/A, clock, CMOS, Forth OS, and networking.

E-PAC 1000 + \$249.00 E-PAC 2000 + \$449.00

EMAC INC.

P.O. Box 2042, Carbondale IL 62901

Phone: 618-529-4525 Fax: 618-457-0110

Inquiry 630.

Rack-Mounted AT 286 or 386

Industrial, Med-Tech, Laboratory and Comm. needs
◊ Intel 80286 or 80386 CPU daughter card ◊ Passive back plane (8-10 expansion slots) ◊ Fits standard 19" rack ◊ Heavy-duty dual fans ◊ Clean air filter ◊ High-speed, high-quality hard disk available ◊ Slide-mounted CPU chassis for easy maintenance access ◊ Power supply up to 360 Watts. For details and prices, Contact:

(516) 589-8666

International

Telecommunications Services

Inquiry 631.

PC CARDS/BREADBOARDS

- AD8-1, 8 bit A/D, digital osc. software \$99
- 8 bit fast A/D, 8CH, GAIN 1,10,100 \$199
- 12 bit A/D, 8CH, S/H, GAIN 1,10,100 \$279
- DIQ24, 24 TTL I/O, 8255 PPI \$89
- Driver, 21-(50V, 300mA) OC outputs \$99
- Printer Port or RS232 Breadboard \$129

JB COMPU-TRONIX

P.O. Box 27717, Lakewood, CO 80227

(303) 987-3239

Inquiry 632.

AWARD BIOS UPDATE!

PC/XT Version 3.1
Now Supports 1.44 Mb 3.5" Floppies

286/386 Version 3.04

Revised Drive Tables, EGA & VGA Support
Authorized AWARD Distributor

1-800-423-3400 or (412) 782-0384

KOMPUTERWERK, INC.

851 Parkview Blvd., Pittsburgh, PA 15215

Inquiry 633.

Wholesale PC Parts

- 286 6/12mhz AT Baby Motherboard \$199
- 1.2 High Density Floppy \$71
- 1200b Modem, Internal \$49
- IBM Compatible Mouse, Serial \$34

Authorized Mark V distributor of IBM Compatibles
Prices starting at \$299

Micro N.W. Distributors

22043 68th Ave. South, Kent, WA 98032

Call: 206-859-9210

Inquiry 634.

- Apple • Service Parts
- Accessories • Systems •
- BUY ★ SELL ★ TRADE

PRE-OWNED Electronics, Inc.

30 Clematis Avenue, Waltham, MA 02154

800-274-5343 FAX 617-891-3556

Service Centers and Dealers welcome

Inquiry 635.

THE BUYER'S MART

HARDWARE/ADD-ONS

The World's First Highest Density Module!

- 16 Meg on the smallest surface
- Organization: 2x1024Kx9 bit
- Package: DIL 64 pin Jedec-Standard
- Technology: CMOS, hybrid, 18xHMS1100JP-10
- Compatibility: With two Hitachi HB56A 19-10
- Suitable for extension of basic memory
- Engineers take notice. This product can be manufactured on large scale.

For more information please write or call:

TermoTrol Corp.

1888 Century Park East, Suite 1900, L.A. CA 90067
Tel: 213-284-3242

Inquiry 636.

HARDWARE/COPROCESSOR

DIGITAL SIGNAL PROCESSOR

DSP products for the IBM PC/XT/AT based on the TI TMS32010 and TMS320C25 up to 12 MIPS operation. Designed for applications in communications, instrumentation, speech, and numeric processing. Offered with 12 bit 110 KHz A/D and D/A and continuous to disk data acquisition & playback option. From \$650.

DALANCO SPRY

89 Westland Ave., Rochester, NY 14618
(716) 473-3610

Inquiry 637.

SC/FOX™ PARALLEL COPROCESSOR

PC/XT/AT/386 plug-in board with Forth software. 10 MIPS operation, up to 50 MIPS burst. 64K to 1M byte memory. Uses Harris RTX 2000™ RISC real-time CPU with 1-cycle multiply, 1-cycle 14-priority interrupts, two 256-word stacks, three 16-bit timer/counters, 16-bit I/O bus. Ideal for real-time control, signal and image processing, and multiple board operation. From \$2,295.

Optional SC/FOX Single Board Computer version for stand-alone operation. Eurocard size with software, starting at \$1,495.

SILICON COMPOSERS, INC. (415) 322-8763
210 California Ave., Suite K, Palo Alto, CA 94306

Inquiry 638.

68000/68020/68881

COMPLETE DEVELOPMENT AND EDUCATIONAL TRAINING SYSTEM for the 68000, 68020, 68881 chips — includes the chips, power supply, serial interface with software, 68000/68020 cross assembler (hosted on a PC), documentation, schematic, Operating System, cables. Special Price — \$1100.00

Phone URDA, Inc.
1-800-338-0517

Inquiry 639.

INVENTORY MANAGEMENT

STOCK-MASTER 4.0

Commercial grade inventory management software at micro prices.

- Supports all 12 transaction types
- Trend Analysis
- Quality Control
- Multiple Locations
- Purchase Order Tracking
- Open Order Reporting
- Serial/Lot # Tracking
- Stock Status Reporting
- Activity History Analysis
- Bill of Materials
- Purchase Order Writing
- Order Entry
- Material Requirements
- On Line Inquiry

Applied Micro Business Systems, Inc.

177F Riverside Ave., Newport Beach, CA 92663 714-759-0582

Inquiry 640.

dFELLER Inventory

Business inventory programs written in modifiable dBASE source code.

dFELLER Inventory \$150.00

Requires dBASE II or III, PC-DOS/CPM

dFELLER Plus \$200.00

with History and Purchase Orders

Requires dBASE III or dBASE III Plus (For Stockrooms)

Feller Associates

550 CR PPA, Route 3, Ishpeming, MI 49849
(906) 486-6024

Inquiry 641.

LANS

The \$25 Network

Try the 1st truly low cost LAN

- Connect 2 or 3 PCs, XTs, ATs
- Uses serial ports and 5 wire cable
- Runs at 115K baud
- Runs in background, totally transparent
- Share any device, any file, any time
- Needs only 14K of ram

Skeptical? We make believers!

Information Modes

P.O. Drawer F, Denton, TX 76202

817-387-3339

Inquiry 642.

LAPTOP COMPUTERS

LAPTOP SPECIALS

TOSHIBA • Zenith • NEC • SHARP LAPTOPS

- Hard drives for Tandy 1400 LT & Toshiba 1100+
- AFFORDABLE 5 1/4" or 3 1/2" DRIVE UNITS for LAPTOPS & DESKTOPS • DICONIX PRINTERS • 768 card for T1000 • 2400 BAUD MODEMS for Laptops • Fast reliable and friendly service. For Low Pricing call

World wide sales

COMPUTER OPTIONS UNLIMITED

201-469-7678 (7 Days, 9 am-10 pm Eastern time)

Inquiry 643.

Laptop Connection

2PC — THE File Transfer Utility

- * Lap to Lap, Lap to Desk
- * Super Easy to Use
- * Breaks the "Bridge-Link" Price Barrier * 115 K Baud
- * Desk to Desk, PC to PC
- * No Installation Required

\$55 w/universal cable, \$45 w/o cable

See Jan. 89 Issue — "What's New" Column — p.94

PLUS... Quality Cables at FAIR Prices:

- * Null Modem (6') \$12
- * Kid Ext (6') \$12
- * Par Print (6') \$10
- * Centronics (6') \$12
- * Mon Ext (6') \$12
- * Serial (6') \$10

MANY MORE CABLES AVAILABLE. Mac & PC (VISA MC)
Thompson Computing—587 F.N. Ventu Park Rd., Ste. 306,
Newbury Park, CA 91320, (805) 498-7653 FAX (805) 499-8104

Inquiry 644.

LAPTOP PERIPHERALS

TOSHIBA PERIPHERALS	T1000	T1200 T1600	T3100 10/20	T3100e T5100
Battery AdaptaPAK (12V)	FX25T	FX3T	P80	P80+
Vehicle Battery Adapter	X2.5		A80	A80+
Built-in 2400bps Modem		M24BI		
Internal 2400bps Modem	M24IC		M24EC & M24ES	
Single COMMS Port Card	S232T		S232E	
Dual COMMS Port Card			D232E	
SCSI Interface Card			SCSIE	

PRODUCT R&D Corporation

1194 Pacific St., Suite 201, San Luis Obispo, CA 93401
(805) 546-9713 or 800-234-5584

Inquiry 645.

MAILING LIST PROGRAMS

YOURS FREE!

"How to Manage Your Mailing List" ArcList® & AccuMail™ are two powerful programs for your IBM or compatible PC.

- Duplicate Recognition
- Postal Discount Presorts
- Label Design & Printing
- Carrier Route and Zip+4 Insertion
- Address Correction
- dBase® Compatible

Call 800-368-5806 for a FREE GUIDE
Group 1 Software, Inc.

6404 Ivy Lane, Dept. BIT-6, Greenbelt, MD 20770-1400

Inquiry 646.

MEMORY CHIPS

MEMORY CHIPS

41256-15-12-10	Call	51000 (1 Meg)	Call
4164-15	Call	51258 for Compaq 386	Call
4164-12	Call	8087-3-2	Call
41128 Piggy Back for AT	Call	80287-6-8-10	Call
41464-12 (64Kx4)	Call	80387	Call
414256 (256Kx4)	Call	NEC-V-20-8	Call
2764,27128,27256,27512	Call	Mouse	Call

Prices subject to change

ESSKAY 718-353-3353

Inquiry 647.

MEMORY CHIPS

MEMORY

NEW OR FULL
64-15 P \$1.25 ONE MEG, ZIP
256-15 P \$5.95 SIP AVAILABLE
256-12 — \$6.95 INTEL CPU IN STOCK
2400 BPS INTERNAL
MODEM VOICE CARD \$69 \$199

ITC

(714) 730-1121 FAX: (714) 730-3837

PRICES SUBJECT TO CHANGE WITHOUT NOTICE
MasterCard VISA

Inquiry 648.

MIDI

LAPTOP PS/2 PC/XT/AT

MIDIATOR™, Music interface with Serial I/O, MIDI In, MIDI Out, & Real-Time clock. Connects any PC compatible RS-232 Port without ext. power, card slot, system mods. Software: KEENote-16 multi-track record/play, edit, save/load, more. MonKEE manages MIDI data. Separately \$249.85. Introductory Special—ALL for \$129.95 + 5.00 S&H USA, MC, VISA, COD, Check (10 days), TX res. add 7.5% tax.

KEE • Key Electronic Enterprises • KEE

9112 Hwy. 80 W., Suite 221-B, Fort Worth, TX 76116

Order 1-800-KEE-MIDI Tech (817) 560-1912

Inquiry 649.

MONITOR INTERFACE

DRIVE MULTIPLE MONITORS

with one PC using our VOPEX video port expanders. Featuring no loss of resolution or color, presentations are more dramatic. We have a VOPEX for PC, PS/2, MAC II & workstations. Units are available from 2 to 10 output ports.

NETWORK TECHNOLOGIES INC.

800-RGB-TECH or 216-543-1646 MC/VISA/AMEX

19145 Elizabeth St., Aurora, OH 44202

Inquiry 650.

MUSIC

MIDI Programmer's Toolkit!

Technical specs, software tools, example programs for popular MIDI interfaces. For IBM PC/XT/AT. Supports Turbo C, Turbo Pascal, Quick C, Microsoft C, Quick Basic, \$39.95 + \$3 S&H. Intelligent MIDI interfaces too, from \$159. VISA/MC

Music Quest, Inc.

2504 Avenue K, #500-492, Plano, TX 75074
(214) 881-7408

Inquiry 651.

OBJECT ORIENTED TOOLS

OBJECT ORIENTED TOOLKIT

TRIPLE your productivity with Complete C™

The only C object oriented development utility with precompiler, foundation classes (source code included), make, integrated debugger, documentation generator, profiler, streamliner, and full technical support.

Introductory Price: \$269

Complete Computer Corporation

111 West 57th St., NY, NY 10019
212-582-2635

Inquiry 652.

PROGRAMMERS TOOLS

IBM ARTIC CARD DEBUGGER

Cut your ARTIC debugging time down to 1/10 OR LESS. Finally, a realtime software debugger for IBM ARTIC cards! Features include setting breakpoints anywhere; forwards and backwards tracing; RCM and task statistics; debug as many cards as you have in your system, concurrently; high level support for setting breakpoints by source code label, and dumping program variables by source code label.

ATLANTIC FIRMWARE

(609) 795-9651

Inquiry 653.

PROGRAMMERS TOOLS

Menu Creator™ \$99.95

A program generator for menu-driven user interface. Edit menu windows interactively using WYSIWYG screen editor—Menu Creator™ generates a linkable menu object file. Excellent for complex menu systems. Capable of handling command trees with hundreds of menu items. Mouse support and context-sensitive help. FORTRAN, PASCAL, C, BASIC supported.

Call your dealer

For free utility software contact: **Avanpro Corp.**
P.O. Box 969, Pacific Palisades, CA 90272
(213) 454-3866

Inquiry 654.

TLIB™ 4.2 Version Control

"TLIB" is a great system!" — *PC Tech Journal 3/88*. Full-featured configuration mgmt for software professionals. All versions of your code instantly available. Very compact, only changes are stored. Check-in/out locks, revision merge, branching, more. Mainframe deltas for **Pansophic, ADR, IBM, Unisys**. Only \$99.95 + S&H, or 5-station LAN \$299.95 + S&H. VISA/MC

BURTON SYSTEMS SOFTWARE

P.O. Box 4156, Cary, NC 27519 (919) 856-0475

Inquiry 655.

Have Same 'C' Source for UNIX and DOS

D-ISAM—Unix standard indexed file management library for UNIX DOS and NETWORKS. Manages all locking. UNIX/DOS source \$595 (for both), DOS libs \$145.

"W"—Character windowing with COLORS, Line Graphics, Bells and more. You need not modify DOS code to work WELL on any UNIX terminal. UNIX/DOS source \$295 (for both), DOS libs \$95.

BYTE DESIGNS

P.O. Box F195-76, Blaine, WA 98230
1-800-663-8547 or (604) 278-5200

*DOS libs available for Microsoft or Borland C compilers

Inquiry 656.

Async Executive™ & Tutorial

Interrupt driven transmit & receive. Supports up to eight ports. Buffered I/O to 64K. 50 to 19200BPS. XON/XOFF. DTE/DCE. Modem controls. Transfer characters or blocks. Millisecond timing. Universal language interface. BIOS/DOS extension capabilities. XMODEM w/CRC. 200+ page comprehensive manual. Sample programs include a spooler written in C. For IBM PC/XT/AT & all compatibles. Software Developer's Kit: \$595. Additional drivers \$50.00

Shipping \$5, Canada \$10, International \$15

CA residents must add sales tax. Checks/MO only.

CIRRUS SOFTWARE, INC.

P.O. Box 51924, Dept. B, Palo Alto, CA 94303

(415) 949-1470

Inquiry 657.

"C" WINDOWING \$49.95

MS-DOS virtual screen library. Unlimited text windows. 100+ functions/macros. Move, resize, hide, pop-up, edit, etc. Attributes, tabs, scroll/alignment bars. K&R print, raw/processed I/O, cursor mgmt. Easy to use. Excellent test. NJ add 6%. \$3.00 S&H. 15 day \$ back. Check or money order. Specify compiler (Microsoft, Lattice, Turbo). Allow 2-4 wks. Write:

Commonwealth Data Systems, Inc.

P.O. Box 568, Lincroft, NJ 07738

Inquiry 658.

MAC DEVELOPMENT TOOLS

Professional Programmers Extender: Standard Mac interface, lists, printing, graphics, tiling. Extender GraphPac: Quality color graphs. Line, bar, semi-log, customizable symbols.

INVENTION Software

(313) 996-8108

Inquiry 659.

PROGRAMMERS TOOLS

TURBO PLUS \$149.95

Programming tools for Turbo Pascal 5.0 Screen Painter, Code Generator, I/O Fields, Dynamic Menus, Programming Unit Libraries, Sample Programs, 280 Page Illustrated Manual. 60 Day Satisfaction Guarantee! Brochures & Demo Diskettes avail. Highly Favorable Reviews! IBM & Compatibles.

Nostradamus Inc.

P.O. Box 9252, Salt Lake City, UT 84109

(801) 272-0671

Inquiry 660.

Get INSIDE!

The best PC software performance tool is now better than ever with source line timing, caller timing and arbitrary event timing—all with microsecond accuracy and without source modification. The expanded DOS analysis mode identifies I/O bottlenecks. \$125

Call today for a free brochure and the latest list of supported compilers. 30-day guarantee. VISA/MC/COD

Paradigm Systems

P.O. Box 152, Millford, MA 01757
(800) 537-5043 In MA: (508) 478-0499

Inquiry 661.

FREE BUYER'S GUIDE

Programmer's Connection is an independent dealer representing more than 300 manufacturers with over 800 software products for IBM personal computers and compatibles. We have serviced the professional programmer since 1984 by offering sound advice and low prices. Call or write today to receive your FREE comprehensive Buyer's Guide.

Programmer's Connection US 800-336-1166

7249 Whipple Ave. NW Canada 800-225-1166
North Canton, OH 44720 International 216-494-3781

Inquiry 661.

'C' DOCUMENTATION TOOLS

- C-CALL \$59 Creates graphic-tree of caller/called structures, and files-vs-procedure table-of-contents
- C-HDR \$59 Creates/inserts/updates headers for each procedure showing caller/called and identifiers
- C-LIST \$39 List, action-diagram, reformat programs
- C-REF \$49 Local/global/parameter cross reference
- SPECIAL \$149 All 4 plus integrated C-COD version

SOFTWARE BLACKSMITHS INC.

8064 St. Ives Way, Mississauga, ONT Canada L5N-4M1
(416) 858-4466

Inquiry 662.

Turbo SuperGen 2.00 \$10 (NEW VERSION)

Add DBase-style, easy to use data entry screen unit to Turbo Pascal 4.0

- Extensive Features:
- Dependent and independent data entry fields control.
 - Definable editing keys (function and cursor keys).
 - Support all data types including arrays, byte, date & time fields.
 - Numerics decimal point alignment and picture controlled I/O fields.
 - Screen painter and data entry unit code generator.
 - Full source code in Turbo Pascal is included.

Complete version with manual and examples on disk. Req. IBM-PC. Only \$10. Another low cost but sophisticated tool from

Software Mission

629/3 Sathupadit Rd., Yannawa, Bangkok 10120 Thailand
TLX 84918 FAX: 2942263

Inquiry 663.

PUBLIC DOMAIN

\$3.00 SOFTWARE FOR IBM PC

Hundreds to choose from, wordprocessors, databases, spreadsheets, games, lotto, communications, business, music, bible, art, education, language and useful utilities for making your computer easier to learn. Most programs have documentation on the disk.

Free 125 page catalog.

BEST BITS & BYTES

P.O. Box 8245, Dept. B, Van Nuys, CA 91409
In CA: (818) 764-9503 800-245-BYTE

Inquiry 664.

PUBLIC DOMAIN

\$1 per DISK SALE

20 TOP IBM PC PD/SW DISKS
(360K) ONLY \$20 + \$3 S&H

QubeCalc, EDRAW, AutoMenu, Math Tutor, PC-DOS Help, Baker's Dozen, Languages, EZ-Form, PC-Style, PackDisk, PC-Stock, KidGames, Best Games, Home Inventory, PC-Outline, Form Letters, ImagePrint, SideWriter, PC-Prompt, Best Utilities.

BRIGHT FUTURES INCORPORATED

P.O. Box 1030, East Windsor, CT 06088
FREE CATALOG (\$1.25 per disk)

Inquiry 665.

FREE CATALOG PUBLIC DOMAIN/SHAREWARE

• 400 IBM PC & compatibles disks •

• 200 Amiga disks • 125 Atari ST disks

PC disks as low as \$1.25 each, Amiga & ST as low as \$1.60 each! Rent or buy. Free shipping! Call toll free, write or circle reader service for FREE BIG CATALOG with full descriptions. Please specify computer—48 hr. turnaround!

Computer Solutions

P.O. Box 354—Dept. B, Mason, Michigan 48854
1-800-874-9375 (M-F 10-6 EST) 1-517-628-2943

Inquiry 666.

- CLIP ART
- GRAPHICS
- LASER FONTS
- CAD
- ELECTRONICS
- GAMES
- TRAVEL
- AUDIO/VIDEO
- SECURITY
- EDUCATION

For FREE CATALOG write to:
CWI Information Services

P.O. Box 4851, Anaheim, CA 92803
800-777-5636

Or telephone (714) 879-7917 24 HOURS!

Inquiry 667.

RENT SOFTWARE \$1/DISK

Rent Public Domain and User Supported Software for \$1 per diskfull or we'll copy, IBM (3 1/2" also), Apple, C-64, Sanyo 550 and Mac. Sampler \$3. VISA/MC. 24 hr. info/order line. (619) 941-3244 or send #10 SASE (specify computer) Money Back Guarantee!

FutureSystems

Box 3040 (T), Vista, CA 92083
office: 10-6 PST Mon-Sat. (619) 941-9761

Inquiry 668.

PUBLIC DOMAIN SHAREWARE

1000's of SELECTIONS Highest Quality

PD SOFTWAREHOUSE

CALL FOR A

FREE CATALOG

1-800-548-7360

Inquiry 669.

FREE IBM SOFTWARE

FREE CATALOG also contains SHAREWARE. 5 1/4 and 3 1/2-inch. All categories. ENGINEERING, CAD, DESKTOP PUBLISHING, LANGUAGES, UTILITIES, BUSINESS, GRAPHICS, SPREADSHEETS, WORD PROCESSORS, CHURCH, MEDICAL, HEALTH, EDUCATION, HOME.

SECTOR SYSTEMS COMPANY, INC.

Dept. B-6, 416 Ocean Avenue, Marblehead, MA 01945
(617) 639-2625

Inquiry 671.

PUBLIC DOMAIN

FREE CATALOG

\$1 IBM SOFTWARE

For your free 32 page Master Edition catalog featuring the best of IBM Shareware from just \$1 each, call or write today!

1-800-338-2118

SOFSOURCE

Box 828, East Lansing, MI 48826

Inquiry 672.

FREE SOFTWARE CATALOG

Low as \$1.20/disk

Over 1000 quality IBM software

On 5.25" and 3.5" format

From outside U.S.A., except Canada,

please send US \$2.00 refundable with order.

For fast service, write to

SOFTSHOPPE

P.O. BOX 709, Ann Arbor, MI 48105
(313) 763-8721

Inquiry 673.

FREE SOFTWARE

We send you 15-20 new IBM programs a month on 5 disks—FREE! You pay only \$5. shipping/handling. Annual membership reg. \$29.95. Join today for only \$9.95 and we'll send you over 30 programs on 10 disks as a bonus—FREE! No gimmicks—no catches!

toll free 800 669-2669 ext 348

SOFTWARE of the MONTH CLUB
we take visa/mastercard/amex

Inquiry 674.

SECURITY

EVERLOCK COPY PROTECTION

- * Thwarts ALL Bit-copy Software
- * Protects any COM/EXE w/o Source changes
- * Shut down Debug Tracing & Disassemblers
- * Install to Floppy, Hard Disk, or LAN
- * Remotely reset Program Install-Count, Expire-Date or #Executes
- * No damaged media or I/O pligs

For IBM and clones. \$195 & up. Free Info.

Az-Tech Software, Inc.

305 East Franklin, Richmond, MO 64085

(800) 227-0644

(816) 776-2700
FAX: (816) 776-8398

Inquiry 675.

THE ULTIMATE COPY PROTECTION

- * Completely Menu Driven
- * Defeats all Hardware/Software Copiers
- * No Source Code Changes
- * Multiple Layering
- * No Damaged Media
- * Full Hard Disk Support
- * Unlimited Metering
- * FREE Demo Disk

Quite Simply

The Best

Way To

Protect

Your Valuable

Software Investment

STOPCOPY™ \$325⁰⁰ STOPCOPY PLUS™ \$450⁰⁰

BBi COMPUTER SYSTEMS® (301) 871-1094

14105 Heritage La., Silver Spring, MD 20906 FAX: (301) 460-7545

Inquiry 676.

BIT-LOCK® SECURITY

Piracy SURVIVAL 5 YEARS proves effectiveness of powerful multilayered security. Rapid decryption algorithms. Reliable/small port transparent security device, PARALLEL or SERIAL port. Complemented by economical KEY-LOCK™ and multifeatured COMPU-LOCK™ including countdown, timeout, data encryption, and multiproduct protection.

MICROCOMPUTER APPLICATIONS

3167 E. Otero Circle, Littleton, CO 80122

(303) 922-6410/770-1863

Inquiry 677.

SECURITY

PC Security "Password"

With All the Computer Security Talk, **PASSWORD** is the Perfect Security Lock.

Password is a software program providing security for your PC. Password is Easy to understand and Simple to install, requires no reformatting. The boot limit option secures your hard disk. Password provides for up to 100 users with the supervisor controlling access to protected directories. Password is menu-driven with pop-up windows and help screens. The program provides an audit trail of users, and a screen blanking feature.

PASSWORD \$99.00 US Visa, M/C, Amex

Nasdec International Inc.

2704-85 Garry Street, Winnipeg MB Canada R3C 4J5
PH: (204) 956-2798 FAX (204) 943-3702

Inquiry 678

COPY PROTECTION

The world's leading software manufacturers depend on Softguard copy protection systems. Your FREE DISKETTE introduces you to SuperLock™—invisible copy protection for IBM-PC (and compatibles) and Macintosh.

- * Hard disk support
- * Customized versions
- * No source code changes
- * LAN support
- * New upgrades available

(408) 773-9680

SOFTGUARD SYSTEMS, INC.

710 Lakeway, Suite 200, Sunnyvale, CA 94086
FAX (408) 773-1405

Inquiry 679.

SOFTWARE/ACCOUNTING

PC TIME CLOCK

AutoTime is an Employee Management System that allows you to turn any PC into an Electronic Time Clock. AutoTime provides Time & Attendance, Job Costing, Payroll Interface, and Labor Distribution reporting. Network compatible. Prices start at \$495. Other Business Products: Network FAX, Absence Call-In, db-EDI.

Chase Technologies

1617 Kingman Ave., San Jose, CA 95128

(408) 998-2917

Inquiry 680.

dBASE BUSINESS TOOLS

- * GENERAL LEDGER
- * ORDER ENTRY
- * JOB COSTING
- * BILL OF MATLS
- * PAYROLL
- * PURCH ORD/INVENTORY
- * ACCOUNTS RECEIVABLE
- * JOB ESTIMATING
- * SALES ANALYSIS
- * ACCOUNTS PAYABLE

\$99 ea. + S&H

dATAMAR SYSTEMS Cred. Card-Check-COD

4876-B Santa Monica Ave.

San Diego, CA 92107

(619) 223-3344

Inquiry 681.

CHAMPION ACCOUNTING SOFTWARE - TRY BEFORE YOU BUY

CHAMPION, ACCPAC SPI	\$239.00
REAL WORLD 4 IN 1	\$199.00
SOLOMON PROFITWISE	\$199.00
SIBT, ACCOUNTMATE	\$395.00
BUSINESSWORKS	\$222.00
ONEWRITE PLUS v 2.0	\$129.00
COMPANY BOOKS	\$199.00
PEACHTREE COMPLETE II	\$149.00
ABRAXAS COMPLETE	\$695.00
OTHERS	CALL

Mail \$1000 for sample program (CHAMPION)

TARIQ INTERNATIONAL

P.O. Box 98427, Atlanta, GA 30359

1-800-221-3934

(404) 564-1128

Inquiry 682.

SOFTWARE/BASIC

Save time, money, & brain cells!

QuickWindows Advanced user-interface library supports windows, menus, dialog boxes, help, mouse, and more. For text and graphics modes thru VGA. Fast and intuitive!

QuickComm communications library supports up to 16 comm ports, Hayes modems, xmodem and ymodem file transfer, and more. All interrupt driven. Easy to use!

Each library written in assembly and comes with complete manual. \$139 each. For Microsoft QuickBasic or BASCOM.

Software Interphase, Inc.

5 Bradley Street, Suite 106, Providence, RI 02908

(401) 274-5465 Call now for FREE terminal/demo program.

Fax # 401-272-1273

Inquiry 683.

SOFTWARE/BUSINESS

DATA ENTRY SYSTEM

Heads-down data entry with two-pass verification for the IBM PS/2-PC/XT/AT & compatibles. Features include: Auto dup/skip, verify bypass, range checks, table lookups, a complete edit language. Fully menu driven. Price \$395

Call for our free 30 day trial period.

COMPUTER KRYE

21929 Makah Rd., Woodway, WA 98020

Tel: 206/776-6443 USA: 800/356-0203 Fax: 206/776-7210

Inquiry 684.

TPRO88—TRANSPORTATION ROUTING

A powerful interactive system for finding optimal routes on transportation networks with up to 512 nodes and 32788 links. TPRO88 finds the shortest and/or quickest path between any two points, solves traveling salesman problems with up to 50 stops, finds minimum spanning trees, computes times and distances between all points on a network. Many features including U.S. interstate highway network, graphics display and editing, stop sequencing, report generator. \$149 with manual and 8087 support.

Eastern Software Products, Inc.

P.O. Box 15328, Alexandria, VA 22309

(703) 360-7600

Inquiry 685.

SOFTWARE/ENGINEERING

Affordable Engineering Software

FREE APPLICATION GUIDE & CATALOG

Circuit Analysis • Root Locus • Thermal Analysis • Plotter Drivers • Engineering Graphics • Signal Processing • Active/Passive Filter Design • Transfer Function/FFT Analysis • Logic Simulation • Microstrip Design • PC/MSDOS • Macintosh • VISA/MC

BV Engineering Professional Software

2023 Chicago Ave., Suite B-13, Riverside, CA 92507

(714) 781-0252

Inquiry 685.

Digital Control Intro	\$200
Digital Filter Tutor	\$450
Kalman Filter Tutor	\$925

Practical hands-on training courses that run on the IBM PC. Ideal alternative to text books, seminars, and university courses. FREE demo disk available.

Engineering Tutorial Software

22338 Lull Street, Canoga Park, CA 91304

(818) 716-0816

Inquiry 686.

PCB THERMAL ANALYSIS

A Printed Circuit Board's greatest enemy is excess heat. Prevent overheating by using PCB THERMAL ANALYSIS SOFTWARE. PCB is an easy to use, fully integrated analysis package that provides concise results. Temperatures are displayed on a topographical color contour plot. Cost \$5000, demo \$15.

KCR PRODUCTS

PO Box 1415, Burleson, TX 76028

Inquiry 687.

SIMULATION WITH GPSS/PC™

GPSS/PC™ is an IBM personal computer implementation of the popular mainframe simulation language GPSS. Graphics, animation and an extremely interactive environment allow a totally new view of your simulations. Simulate complex real-world systems with the most interactive and visual yet economical simulation software.

MINUTEMAN Software

P.O. Box 171/Y, Stow, Massachusetts, U.S.A.

(508) 897-5662 ext. 540 (800) 223-1430 ext. 540

Inquiry 688.

THE BUYER'S MART

SOFTWARE/ENGINEERING

Circuit Analysis — SPICE

Non-linear DC & Transient; Linear AC.
 *Version 3B1 with BSIM, GaAs, JFET, MOSFET, BJT, diode, etc. models, screen graphics, improved speed and convergence.
 *PC Version 2G6 available at \$95.
 Call, write, or check inquiry # for more info.

Northern Valley Software

28327 Rothrock Dr., Rancho Palos Verdes, CA 90274
 (213) 541-3677

Inquiry 689.

FREE ENGINEERING MAGAZINE

Personal Engineering is a monthly magazine sent free of charge (USA only) to scientists/engineers who use PCs for technical applications. Topics each month include **Instrumentation • Data Acq/Control • Design Automation**. To receive a free sample issue and qualification form either circle below or send request on letterhead to:

Personal Engineering Communications
 Box 300, Brookline, MA 02146

Inquiry 690.

LCA-1 LOGIC CIRCUIT ANALYSIS

Interactive digital circuit simulation with over 25 standard primitive types, batch mode, macro models, design rule checks, multiple inputs.

- Advanced 4 state, event driven simulator.
- Built in graphics.
- Typical, Min/Max, or Zero delay timings.

LCA-1 1.10 IBM PC \$495 FREE DEMO.

Tatum Labs, Inc.

3917 Research Park Dr. B-1, Ann Arbor, MI 48108
 313-663-8810

Inquiry 691.

TUTSIM™

- Time Domain
- Control sys. Simulation
- Linear and nonlinear
- Block Diagram Syntax
- Transient response
- \$40 (eval copy)/\$495

FANSIM™

- Frequency Domain
- FFT, Inverse FFT
- Find Xier Functions
- Find roots, poles
- Bode, Nyquist, tables
- \$40 (eval copy)/\$395 full

Info, examples: **TUTSIM Products**

200 California Ave., #212, Palo Alto, CA 94306
 (415) 325-4800

Inquiry 692.

SOFTWARE/FINANCIAL

SCAN-A-GRAPH

Paper graphs, charts into Lotus-123 etc. See a Graph in a book, msg, or newspaper: Scan it with your hand-scanner, and SCAN-A-GRAPH converts it to numbers for LOTUS-123. Stats packages, etc. Replot, correlate, analyse, predict. Make a million! Converts line graphs in TIF image files from scanner to ASCII numeric files. Normalizes different graphs. Needs IBM PC and Scanner. Mouse optional. Simple to use.

\$295.00 inc. disk, manual, airmail postage. Visa, Amex.

System Solutions Pty Ltd

28 Palmerston st, BERWICK Vic 3606 AUSTRALIA
 Fax (61) 3 707 2900 Tel (61) 3 707 2651

Inquiry 693.

SOFTWARE/FORECAST

FORECASTING PC/SIBYL™

The classic collection of business forecasting software. Fully revised & expanded: • 19 forecasting models • Faster • Easier to use • Full statistics • By Spyros Makridakis, internationally recognized forecaster. Two disk set now \$495 plus \$25 postage & handling; or \$20 for demo disk (credited toward purchase).

APPLIED DECISION SYSTEMS

33 Hayden Ave., Lexington, MA 02173
 Call: (617) 861-7580

Inquiry 694.

SOFTWARE/FORTRAN

EXPAND & EXTEND LIBS

122 FORTRAN callable routines. **EXPAND** allows DOS compilers access to LIM/EMS 3.2 or 4.0 expanded memory. **EXTEND** provides CGA, EGA, VGA, Hercules, HP, Tektronix, AutoCAD DXF graphics, access to BIOS/DOS functions plus additional utilities. **EXPAND** \$119, **EXTEND** \$149, both \$218.

DESIGN DECISIONS, INC.

P.O. Box 12884, Pittsburgh, PA 15241
 (412) 941-4525

Inquiry 695.

SOFTWARE/GEOLOGICAL

GEOLOGICAL CATALOG

Geological software for log plotting, gridding/contouring, hydrology, digitizing, 3-D solid modelling, synthetic seismogram, fracture analysis, image processing, scout ticket manager, over 50 programs in catalog, Macintosh too! Please call, or write, for Free Catalog!

RockWare, Inc.

4251 Kipling St., Suite 595, Wheat Ridge, CO 80033 USA
 (303) 423-5645

Inquiry 696.

SOFTWARE/GRAPHICS

PC TECHNICAL GRAPHICS

TEKMAR is a graphics library for the EGA or Tecmar Graphics Master. Similar to PLOT-10, includes WINDOW, VIEWPORT, AXIS. Support for HP, HI plotters. Curve fitting, complete plotting program. Log, semi-log, multi-axis, 3-D, contours. Jerry Pournelle (Aug 86 Byte): "As good as any I have ever seen..." Demo disks, literature available.

Advanced Systems Consultants

21115 Devonshire St. #329, Chatsworth, CA 91311
 (818) 407-1059

Inquiry 697.

QuickGeometry Library

Many powerful math subroutines for CAD/CAM and graphics; LINES, ARCS, CIRCLES, ELLIPSES, NON-UNIFORM RATIONAL B-SPLINES W/OFFSET (NURBS); INTERSECTION (even splines); ROTATE, SCALE, TRANSLATE, MIRROR, OFFSET, BREAK, TRIM, ENDPOINTS, TANGENTS, CURVATURE; DXF i/o; lists. IBM PC comp MS-DOS 2+; \$199.00 + no S&H; incl C source, manual, support, 30-day guarantee.

Building Block Software

P.O. Box 1373, Somerville, MA 02144
 (617) 628-5217

Inquiry 697.

PROFESSIONAL GRAPHICS FOR SCIENTISTS AND ENGINEERS PC/MSDOS • Macintosh FREE 48 page Catalog

Linear/Log Scaling • Graphs with error bars • AUTO PLOT • BATCH Mode • Multiple Y-axes • Multiple data files • Auto/Forced Scaling • Full labeling • Built-in editor • 1-2-3 Interface • Curve fitting • Statistics • CGA, EGA & Hercules Compatible. 40 pen plotters supported.

BV Engineering Professional Software

2023 Chicago Ave., Suite B13, Riverside, CA 92507
 VISA/MC (714) 781-0252

Inquiry 698.

CADpac

Software Development Tools
 For CAD and Graphics Programmers

- MATHpac
- SPLINEpac
- PLOTpac
- GEOMETRYpac
- VIEWpac
- SHAPEpac
- MATRIXpac

General 2D & 3D graphic and utility libraries for C. Each CADpac includes complete C source code, programmers manual, and sample programs. \$35 each CADpac + \$2 s/h.

DesTek, Inc.

Design Technology
 P.O. Box 176, Kenmore, NY 14217

Inquiry 699.

SOFTWARE/GRAPHICS

Technical Report Graphics

Edit data and graphics with EDTECH for \$65
 — Database, worksheet-style data editing
 — Technical XY plots from data for reports
 — Graphics editing on screen, drawing, text
 — 180x180 dots/inch output, 24-pin pit req'd
 — Log axes, Greek, symbols, Lotus implex

DIGITAL ANALYTICS

P.O. Box 31430, Houston, TX 77231
 (713) 721-2069

Inquiry 700.

TurboGeometry Library

Over 150 2&3 dimensional routines, includes Intersections, Transformations, Equations, HiddenLines, Perspective, Curves, Areas, Volumes, Clipping, Planes, Vectors, Distance, Polydecomp, IBM PC and Comp. MAC. MSDOS 2+. Turbo Pascal, Turbo C, MSC & Turbo Pascal MAC. 400 pg. manual, source code \$149.95 + 5.00 S&H. Foreign add \$16.00. VISA, MC, Chk, P.O. 30 Day guarantee.

Disk Software, Inc.

2116 E. Arapaho Rd., #487, Richardson, TX 75081
 1-800-635-7760
 (214) 423-7288 FAX: 214-423-4465

Inquiry 701.

SEGS 2.0 Scientific Engineering Graphics System

- Logarithmic, Time/Date & Linear Axes.
- Easy Curve Fitting and Data Smoothing.
- 1-2-3 Interface & Numeric Spreadsheet.
- Supports all Video & Device Standards.
- 10 Curves with up to 8000 points each.

Edmond Software, Inc.

5900 Mosteller Dr. #1124 405-842-0558
 Oklahoma City, OK 73112 800-284-3381

Inquiry 702.

PEN PLOTTER EMULATOR

FPLOTT turns your dot matrix or laser printer into an HP pen plotter. Fast hi-res output. No jagged lines. Vary line width, color. Works with Autocad, Drafrix, etc. Supports NEC P5/P6, IBM Proprinter, Epson LQ/FX, Toshiba, HP Laserjet. Hercules/CGA/EGA/VGA for preview. \$64 check/m.o.

FPLOTT CORPORATION

24-16 Steinyway St., Suite 605, Astoria, NY 11103
 212-418-8469

Inquiry 703.

GRAPHICS PRINTER SUPPORT

AT LAST! Use the PrtSc key to make quality scaled B&W or color reproductions of your display on any dot matrix, inkjet, or laser printer. GRAFFPLUS supports all versions of PC or MS-DOS with IBM (incl. EGA, VGA), Tecmar, and Hercules graphics boards. \$49.95.

Jewell Technologies, Inc.

4740 44th Ave. SW, Seattle, WA 98116
 800-628-2828 x 527 (206) 937-1081

Inquiry 704.

FORTRAN PROGRAMMER?

Now you can call 2-D and 3-D graphics routines within your FORTRAN program.

- GRAF/MATIC: screen routines \$135.
- PLOT/MATIC: plotter driver 135.
- PRINT/MATIC: printer driver 135.

For the IBM PC, XT, AT & compatibles. We support a variety of compilers, graphics bds., plotters and printers.

MICROCOMPATIBLES

301 Prelude Dr., Dept. B, Silver Spring, MD 20901 USA
 (301) 593-0683

Inquiry 705.

THE BUYER'S MART

SOFTWARE/GRAPHICS

GRAPHIC TOOLS LIBRARY

NOVA XGLIB: High speed. Window/viewport, arcs, splines, figure fill, paint, borders, text scale/orient/align, bitmaps, bibbit, pens, keyboard, mouse, image capture. Over 150 functions. **\$75.** **PC_VDI:** Includes Segment, virtual mem. **\$395.** Both products ANSI CGI compatible, drivers for printer, plotter, HP laser. CGA/EGA/VGA. For most "C" compilers, MS FORTRAN, QuickBASIC. Demos, manual.

NOVA, INC.

P.O. BOX 68976, Schaumburg, IL 60168
312-882-4111

Inquiry 706.

SOFTWARE/INVESTMENT

Compare over 1,300 Mutual Funds with Business Week's Mutual Fund Scoreboard and your IBM PC or compatible. Use simple menu commands to search and sort on over 25 information fields. No additional software required. Data transports easily to Lotus 1-2-3. Search, total, average, rank, display and print reports—at the touch of a key!

Only **\$69.95** each for an Equity or Fixed Income Diskette **\$199.95** per subscription for either the Equity or Fixed Income version **\$319.95** for a subscription to both versions (a savings of **\$90!**)

Order now or receive more information by calling 1-800-553-3575 (In Illinois, call 1-312-250-9292)

Or write to: **Business Week Diskettes**
P.O. Box 621, Elk Grove, IL 60009

Inquiry 707.

STOCKS OPTIONS FUTURES

Turn Your PC Into A

MARKET QUOTATION MONITOR

85 page book covers satellite and radio data reception of financial news and quotes for your PC, \$19 (includes demo diskette). Free informative catalog of

- Data receivers and kits
- Quote processing and display software
- Descrambling software utilities

303-223-2120 \$2 Shipping & Handling

DATArx

111 E. Drake Rd., Suite 7041, Fort Collins, CO 80525

Inquiry 708.

SOFTWARE/LANGUAGES

FORTH with DRUMA FORTH-83

Break the 64K barrier without speed/space penalty. Well designed, attractively priced. '83 Standard.

- IBM+ automated memory management
- On-line documentation, ASCII/block files
- Many powerful and useful features
- Other products: windows, modules, profiler
- IBM PC/XT/AT & all compatibles

Write or call for FREE example diskette.

DRUMA INC.

6448 Hwy. 290 East E103, Austin, TX 78723

Orders: 512-323-0403 BBoard: 512-323-2402

Inquiry 709.

FORTRAN for Macintosh

Language Systems FORTRAN is a full-featured FORTRAN 77 compiler integrated w/MPW. Full ANSI FORTRAN 77 plus VAX-type extensions. SANE numerical calculations & data types incl. COMPLEX*16, 68000, 68020 and 68881 object code. Arrays greater than 32K. Link with Pascal, C, MacApp. \$359 w/MPW vs air. MC/VISA/Check. MAC+, SE, Mac II. HD req.

Language Systems Corp.

441 Carlisle Drive, Herndon, VA 22070

(703) 478-0181

See our ad on page 231

Inquiry 752.

TO: ARABS in America/Canada/Europe/Australia/Etc Arabic Software & Manuals

We are the largest shippers of the above etc. at the cheapest prices ever to any part of the world!!!

HURRY! Call Us Now and ask for our free list!

MY COMPUTER

TEL 00971 (2) 335030 Box 7198 Abu Dhabi, U.A.E
TLX 23490 MYCOMP EM, FAX 00971 (2) 342871

Inquiry 710.

346 B Y T E • JUNE 1989

SOFTWARE/MATHEMATICS

MATH EDITING FOR THE PC

$$x^2 = \sum_{k=0}^{\infty} x_k^{2ks} \left(\frac{1}{\alpha \pm \beta x} \right)$$

- MathEdit constructs math equations to be inserted into WordPerfect and manuscript documents.
- User-friendly interface—no new word processor needs to be learned
- MathEdit—\$149

K-TALK COMMUNICATIONS

50 McMillen Ave., Suite 100
Columbus, Ohio 43201
(614) 294-3535

Inquiry 711.

SOFTWARE/MUSIC

IBM MUSIC FEATURE CARD!

Option card with 8 voice, multi-timbral MIDI synthesizer on board. Includes 240 pre-programmed Yamaha sounds, 96 programmable patches and a MIDI in/out thru interface. Use two cards to double capacities. An all-in-one MIDI Studio for IBM and compatibles for only \$495. Software available for recording, arranging and educational needs. Packages recommended. Dealers, catalogers, & VARS call for discount schedule.

Distributed by MIX BOOKSHELF

6400 Hollis St., #12, Emeryville, CA 94608 (415) 653-3307

1-800-233-9604

Inquiry 712.

The ENTER-tainer Clip Music & Utility

300 Songs & Sound Effects - FUN & Educational!

By far the biggest & best collection on the market for DOS machines. Play like a jukebox through your PC speaker or clip & distribute in your own programs. BASIC source code included—no royalties required. Info-packed 172-page manual. 5.25" or 3.5" disks. Requires BASIC 2.0 or later. \$29.95 + \$3.50 S&H MC/VISA/MD. Money Back Guarantee!

PDI Music Software

P.O. Box 18655, Boulder CO 80308

(800) 727-4140 In Colorado (303) 440-4140

Inquiry 713.

SOFTWARE/PACKAGING

HARD TO FIND COMPUTER SUPPLIES FOR SOFTWARE DEVELOPERS & POWER USERS

Cloth binders & slipcases like IBM's. Vinyl binders, boxes, and folders in many sizes. Disk pages, envelopes, & labels. Low quantity imprinting. Bulk disks. Everything you need to bring your software to market. Disk and binder mailers. Much more! Low Prices! Fast service. Call or write for a FREE CATALOG.

Anthropomorphic Systems, Limited

376-B E. Saint Charles Rd., Lombard, IL 60148

1-800-DEAL-NOW 312-629-5160

Inquiry 714.

SAVE SAVE SAVE SAVE

LET'S TALK LABELS

We do disk labels (5 1/4" & 3 1/2")

- Better • Faster • Cheaper •

Because we specialize in disk labels... Let's Talk.

We also have Tyvek Sleeves

Mailers • Binders • Vinyl Pages

We are a complete software packaging service.

Hice & Associates

9303 Cincinnati-Columbus Rd., West Chester, OH 45069

513-777-0133

Inquiry 715.

SOFTWARE/PRINTING

PRINTER GENIUS

Powerful memory resident printer management • Control printer features from menus or within documents • Print spool to disk files or memory • Background print • File & directory browse • Edit small text • and more... • User friendly pop-up screens • 92 page manual • Preset for all printers • Completely flexible • PC MS-DOS • \$89 + \$4 S/H • VISA/MC

Nor Software Inc.

527 3rd Ave., Suite 150, New York, NY 10016

(212) 213-9118

Inquiry 716.

SOFTWARE/SCANNERS

Optical Character Recognition

Stop retyping: PC-OCR™ software will convert typed or printed pages into editable text files for your word processor. Works with HP ScanJet, Panasonic and most other scanners. Supplied with 18 popular fonts. User trainable: you can teach PC-OCR™ to read virtually any typestyle, incl. foreign fonts. Proportional text, matrix printer output, Xerox copies OK. \$385. Check/VISA/MC/AmExp/COD

Essex Publishing Co.

P.O. Box 391, Cedar Grove, NJ 07009

(201) 783-6940

Inquiry 717.

SOFTWARE/SCIENTIFIC

DATA ACQUISITION & ANALYSIS ON PC'S

- Free application assistance. Tell us about your DSP, process control, A/D or D/A needs. Our expert engineering staff will provide you with a system solution to fit your needs and budget.
- A/D & IEEE 488 boards from Metrabyte, Scientific Solutions and National Instruments.
- Analysis software including PRIME FACTOR FFT subroutine library, FOURIER PERSPECTIVE II advanced linear systems analysis.
- Menu driven software from Unihel, Laboratory Technologies, Quinn-Curtis, and Golden. Scientific Engineering 2 & 3D graphics.

See "What's New" page 80, BYTE July, 1988

ALLIGATOR TECHNOLOGIES

P.O. Box 9706, Fountain Valley, CA 92708

Tel. (714) 850-9984 FAX. (714) 850-9987 MCI: ALLIGATOR

Inquiry 718.

POWERFUL EQN SOLVER

RISK FREE \$99 OFFER With Top 10 Word Processor!

"Simple to differentiate or integrate." SCI.Soft

Graph across singularities • Non Linear • Coupled (singular) diff eqn • Any order any number • Indefinite (singular) integrals • New functions/algorithms/solutions • Fit 60th order curves to imported data • COMPLEX/real roots • Programming • 47 predefinitions • 14 digit accuracy • More • "Dev. over 40 years" EETimes • MS-DOS, 640KB, graphics card • CURVE™

CALL TODAY 800-648-5353 x100

VISA/MC/COD/Check

Curve Systems International

11693 San Vicente Blvd., Suite 350, L.A., CA 90049

Inquiry 719.

Chaos/Nonlinear Dynamics

- Ordinary and Delay Differential Equation Solvers • Bifurcation Diagrams • 2- and 3-D Plotting, Sequential Magnification, Poincaré Sections • Next Maximum, 1-D & Circle Maps • Phase Portraits with Multiple Initial Conditions • Spectral Analysis

Fractal Dimensions, Lyapunov Exponents

DS-I \$250.00 DS-II \$350.00

CHAOS IN THE CLASSROOM \$49.95

DYNAMICAL SYSTEMS, INC.

P.O. Box 35241, Tucson, AZ 85740, 602-825-1331

Inquiry 720.

C SCIENTIFIC LIBRARY

Extensive library of matrix, mathematical and statistical routines. Developed and documented for use by technical specialists and C programmers in research, education, engineering, and scientific applications. Over 550 functions, superior documentation—four manuals, including Tutorial, Function Pages, and Example Programs. Includes Real and Complex Linear Algebra, Eigensystems, Differential Equations, Quadrature, Smoothing, Filtering and Prediction, MultiVariate Statistics, Multi-Dimensional Optimization, Linear Programming, Curve Fitting and Interpolations, etc. \$295 object only and \$395 with C source code.

EIGENWARE TECHNOLOGIES

13090 La Vista Dr., Saratoga, CA 95070 (408) 867-1184

Inquiry 721.

Do You Need to do This on Your PC?

$$\frac{614 \frac{1}{8} \text{ cu in}}{1.2 \frac{\text{liter per sec}}{\text{sec}}} = 8.386421$$

Lascaux1000, "The Intelligent Calculator". (For IBM PC's) Verify logic of calculations. Reduce steps by 50%. Extensive table of physical constants. Easily customized. Much more! \$95.95 Demo disk \$1.

Lascaux Graphics \$99.95
Bronx, NY 10467 3220 Steuben Ave. (212) 654-7429

Inquiry 722.

THE BUYER'S MART

SOFTWARE/SCIENTIFIC

ORDINARY/PARTIAL DIFFERENTIAL EQN SOLVER

FOR THE IBM PC & COMPATIBLES

MICROCOMPATIBLES INC.

301 Prelude Dr., Silver Spring, MD 20901

(301) 593-0683

Inquiry 723.

OUR CATALOG WILL SAVE YOU TIME AND MONEY!

It describes (i) GRAPH, a \$79 scientific plotting program, (ii) MINSQ, a powerful \$179 package for curve fitting and model development, (iii) LAPLACE, a simulation program employing numerical inversion of transforms (\$249), and (iv) RSTRIP for exponential stripping (\$249). Call today for our free 16 page catalog with detailed technical application notes.

MicroMath Scientific Software

Salt Lake City, Utah 84121-3144

For orders or catalogs call: (800) 942-MATH.

Inquiry 724.

DialSEARCH data transfer by phone; prestores search strategies for your literature and data searches on DIALOG, BRS, STN, or other data bases. Cuts down on-line time. Dialsearch saves your results automatically, eliminating the risk of losing your data.

The unique user interface allows even novices to perform on-line searches without special training. For \$85 on IBM PC 5 1/4", IBM 3 1/2", CPM 5 1/4", and Apple Macintosh disks. 30 day \$ back. VISA/MC/PO.

Scientific LOGICS Inc.

21910 Alcazar Ave., Cupertino, CA 95014

(408) 446-3575 Compuserve 74017,6643

Inquiry 725.

SP-4 Plotting Program

Linear, Log, Weibull, Normal, Lognormal Axes
• 60,000 data • Curve fitting • 20 symbols •
Transformations • CGA/EGA/HP Plotters.

Send for our 32 page catalog of engineering/scientific software.

Software Consulting Group

P.O. Box 3298, Santa Clara, CA 95055

(408) 446-1008

Inquiry 726.

SOFTWARE/SECURITY

CodeSafe™ Virus Protection System

Thousands of copies in use since 1986 • Protects all hard disks, any size
• Protects all COM, EXE, and associated OVL files (Not just the system files
(like other products) • Detects corruption of Boot sector, and DOS • Supports
all PC/IMS DOS machines • DOS 2.0 to 4.0 • Mono, Her, CGA, EGA
• Includes both 5 1/4" and 3 1/2" disks • Transparent to user • Warning win-
dows will open, with options if a problem occurs • Memory resident approx.
10 to 20 K, depending on the number of files.

TOLL FREE TECH SUPPORT • 30 Day Money Back Guarantee
NOT COPY-PROTECTED \$99.95 Visa and Master Card accepted

ChrisWare, Inc.

15415 N. Eden Dr., Eden Prairie, MN 55346

24 HOUR SERVICE TOLL FREE 1-800-325-8448

In Minnesota or International Call Collect (612) 949-1116

Inquiry 727.

SOFTWARE/SORT

OPT-TECH SORT/MERGE

Extremely fast Sort/Merge/Select utility. Run as an MS-DOS command or CALL as a subroutine. Supports most languages and filetypes including Btrieve and dBASE. Unlimited file sizes, multiple keys and much more! MS-DOS \$149. XENIX \$249.

(702) 588-3737

Opt-Tech Data Processing

P.O. Box 678 - Zephyr Cove, NV 89448

Inquiry 728.

STATISTICS

SX STATISTIX

PC Magazine Editors Choice!

- Easy to learn and use • Fast Free Support
- Money Back Guarantee

At \$179 SX outperforms higher priced programs!

If you value your time and money,
call today for FREE SX demo disk

612-631-2852

Analytical Software Box 13204, Roseville, MN 55113

Inquiry 729.

The BASS System™

Why use up 8 meg and 640K just to run a data step on your PC? Now you can run your data step code and statistical procs with a system that takes only 1 meg and 400K (and costs only \$399)! Free information:

BASS Institute, Inc.

P.O. Box 349, Chapel Hill, NC 27514

(919) 933-7096 or BB: (919) 968-6755 (N,8,1)

Inquiry 730.

Go with SOLO

Statistics and graphics for the PC. Quick and easy to use. All the popular statistics plus the latest in graphics. For business professionals for occasional use, researchers for basic statistics, or students. Satisfaction guaranteed! \$149 complete with graphics. Call today. VISA or MC.

BMDP Statistical Software, Inc.

1440 Sepulveda Blvd., Suite 316, Los Angeles, CA 90025

(213) 479-7799

Inquiry 731.

STATA

NEW RELEASE NOW AVAILABLE. Even better graphics, expanded on-line help, and much more. Still only \$590. Quantity and Academic Discounts available. \$20 Demo. Call toll-free for more information. AX/VISA/MC.

1-800-STATAPC

Computing Resource Center

10801 National Boulevard, Los Angeles, CA 90064

(213) 470-4341

Inquiry 732.

THE SURVEY SYSTEM

An easy-to-use package designed specifically for questionnaire data. Produces banner format, cross tabs & related tables, statistics (incl. regression) & bar charts. Codes and reports answers to open-ended questions. All reports are camera-ready for professional presentations. CRT interviewing option.

CREATIVE RESEARCH SYSTEMS

15 Lone Oak Ctr., Dept. B, Petaluma, CA 94952

707-765-1001

Inquiry 733.

STATISTICS CATALOG!

Call for the catalog full of professional programs for general statistics, analysis of variance, regression, questionnaire analysis and quality control. Thoroughly tested and easy to use, the programs come with complete documentation. Programs available for PC or Apple II. Call toll free now for your free catalog.

HUMAN SYSTEMS DYNAMICS

9010 Reseda Blvd., Suite 222

Northridge, CA 91324

(800) 451-3030 (818) 993-8536 (CA)

Inquiry 734.

STATISTICS

STATISTICAL NAVIGATOR™

Statistical Navigator an expert system using AI strategies to help guide the researcher to the appropriate statistical analysis. Based on your answers, it suggests several analyses ranked by suitability. It explains what the analysis does and how it fits your objectives and assumptions. Special intro price \$99.95+s/h.

VISA/MC/AMEX/PO, 30 day-guarantee.

The Idea Works, Inc.

100 West Briarwood, Columbia, MO 65203

1-800-537-4866 314-445-4554

Inquiry 735.

SIR/DBMS DEMO KIT (7.5 Mb) \$49.95

Since 1976, SIR/DBMS has PIONEERED Advanced DBMS Technology DESIGNED to handle the changing complexities of Scientific, Engineering, and Research Database Management. SIR/DBMS is also DESIGNED to Provide THE BEST DIRECT interfaces to SAS, SPSS, BMDP, & SYSTAT. SIR/DBMS offers True Application Level Portability from PCs thru Supercomputers!

MAYBE YOU SHOULD TRY SIR/DBMS??

Order Now! Ref Buyer's Mart Special Offer!

SIR, A Division of Inter Systems Inc.

312-480-9270 (IL)

703-642-1600 (VA)

Inquiry 736.

MINITAB's a PC of cake!

MINITAB's intuitive commands are easy to use and remember. Features descriptive statistics, regression, time series, chi-square, hi-res graphics, much more. PC version incl. LOTUS interface, data editor, network pricing. Call for FREE brochure.

Minitab, Inc.

3081 Enterprise Dr., State College, PA 16801

(814) 238-3280

Inquiry 737.

NCSS

Professional, easy to use, menu driven statistical system. Used by over 5,000 researchers.

- 5.0 Statistical System —\$99
- 5.1 Graphics (2D & 3D)—\$59
- 5.3 Power Pac Supplement—\$49
- 5.4 Exp. Design/QC—\$49
- 5.5 Survival Analysis—\$59
- 5.6 Forecasting—\$69

We accept checks, PO's, Visa, MC. Add \$3 s/h.

NCSS-B 801-546-0445

865 East 400 North, Kaysville, UT 84037

Inquiry 738.

SCA STATISTICAL SYSTEM

The *only* statistical software encompassing Forecasting & Time Series Analysis Quality and Productivity Improvement General Statistical Analysis

Available on both DOS and OS/2 operating systems.

Call today for more information

Scientific Computing Associates

4513 Lincoln Ave., Suite 106, Lisle, IL 60532, USA

Phone: (312) 960-1698 FAX: (312) 960-1815

Inquiry 739.

StatPac Gold™

StatPac Gold is the award-winning statistics and forecasting package that delivers. It's fast, flexible, easy to use and dependable. Time-tested and loaded with features. You be the judge. Get the facts! Call for your FREE brochure.

1-800-328-4907

Walonick Associates, Inc.

6500 Nicollet Ave. S., Minneapolis, MN 55423

(612) 866-9022

Inquiry 740.

THE BUYER'S MART

UTILITIES

BETTER PRINTER CONTROL

PRINTSELECTOR provides a menu of printer functions & embeds printer control inside documents. Its better because menu controlled menu generators allow you to customize embedded controls and menus for your printer and your needs. MSDOS 5.25" only \$50.00+\$4.00 S/H+6.5% sales tax in CA to order or receive info.

Brook King Systems

10064-7 Larwin Ave., Chatsworth, CA 91311
(818) 882-8451

Inquiry 741.

UTILITIES

Recover deleted files fast!

Disk Explorer now includes automatic file recovery. You type in the deleted file's name, Disk Explorer finds and restores it. Disk Explorer also shows what's really on disk; view, change or create formats, change a file's status, change data in any sector. MS-DOS \$75 U.S. Check/Credit card welcome.

QUAID SOFTWARE LIMITED

45 Charles St. E. 3rd Fl.
Toronto, Ontario, Canada M4Y 1S2
(416) 961-8243

Inquiry 742.

UTILITIES

\$79.95!!

Order the RED Utilities now! Programs include: Disk cache speeds hard and floppy disks. Printer spooler. Batch file compiler speeds batch files. Path command for data files. Wild card exceptions. Sort directories. Over 10 more programs. IBM PC. Visa/MC. Send for free catalog.

The Wenham Software Company

5 Burley St., Wenham, MA 01984 (508) 774-7036

Inquiry 748.

BRIDGE-IT 3.5

This device driver supports 3 1/2 drives in both 720K and 1.44mb capacity on PC/XT/AT model compatibles without upgrading DOS or changing BIOS. Bridge the gap to PS/2 and laptop systems.

Only \$59 + \$4 S/H VISA/MC/COD UPS B/R

MICROBRIDGE COMPUTERS

655 Sky Way, San Carlos, CA 94070
ORDER TOLL FREE 1-800-523-8777
415-593-8777 CA FAX 415-593-7675
514-845-0818 (CAN)

Inquiry 742.

ARABISE YOUR PC!

The ARABKIT package converts your PC to a fully bilingual Arabic/Latin system. Run popular software (Lotus 1-2-3, dBase III+, etc.) in English AND/OR Arabic, with on screen Arabic characters and NLQ printing. ARABKIT comes with a free copy of ALBAYAN, a dedicated and powerful bilingual word processor.

EGA version-\$299 MONO version (inc Mono card)-\$349
Add 15% VAT if ordering in U.K.

ROCKETFIELD COMPUTER SYSTEMS

86 Birch Hill Lane, Manchester M13 0XZ, U.K.
Tel: 061-224 4032 FAX: 061-256-3279

Inquiry 745.

WORD PROCESSING

FARSI / GREEK / ARABIC / RUSSIAN

Hebrew, all European, Scandinavian, plus either Hindi, Punjabi, Bengali, Gujarati, Tamil, Thai, Korean, Viet, or IPA. Full-featured multi-language word processor supports on-screen foreign characters and NLQ printing with no hardware modifications. Includes Font Editor. \$355 dot matrix; \$150 add'l for laser; \$19 demo. S/H in U.S. incl'd. Req. PC, 640K, graphics. 30 day Guarantee. MC/VISA/AMEX

GAMMA PRODUCTIONS, INC.

710 Wilshire Blvd., Suite 609, Santa Monica, CA 90401
213/394-8622 Tlx: 5106008273 Gamma Pro SNM

Inquiry 749.

COPY AT TO PC

The 1.2mb drive has long been known to READ but NOT reliably WRITE on 360KB floppies. With "CPYAT2PC"™ 1.2mb drives CAN reliably WRITE 360KB floppies saving a slot for a second hard disk or backup tape. "CPYAT2PC" (Not Copy Protected) offers the preferable SOFTWARE SOLUTION! ONLY \$79+\$4 S/H VISA/MC/COD UPS B/R

MICROBRIDGE COMPUTERS

655 Skyway, San Carlos, CA 94070
Order toll free 1-800-523-8777
415-593-8777 (CA) FAX 415-593-7675
514-845-0818 (Canada)

Inquiry 743.

DATABASE UTILITIES

NORTAK Software Ltd. now offers a menu-driven ASSIST-like file utility for dBASE, Clipper, and FoxBASE. Self-contained (.EXE file), fast and simple to use.

SINGLE VERSION—\$35; 3-VERSION PACKAGE—\$60.
To order call:

SHOSHIN Systems Inc.

USA 1-800-267-0755 Canada 1-800-267-8856
Info Only 613-235-2310
VISA and MC accepted

Inquiry 746.

DuangJan

Bilingual word processor for English and: Armenian, Bengali, Burmese, Euro/Latin/African, Greek, Gujarati, Hindi, Khmer, Lao, Punjabi, Russian, Sinhalese, Tamil, Telugu, Thai, Ukrainian, Viet, ... Only \$109+\$5 s/h (foreign + \$12 s/h). Font editor included. For any IBM compatibles with dot-matrix & LaserJet printer. Demo \$9+\$1 s/h.

MegaChomp Company

3438 Cottman Ave., Philadelphia, PA 19149-1606
(215) 331-2748 FAX: (215) 331-4188

Inquiry 750.

STANDARD GRAPHICS

NOVA XGLIB: Optimized. Window/viewport, arcs, splines, figure fill, borders, text (scale, rotate, align), bitmaps, bitbit, keyboard, mouse, image capture. Over 150 functions. \$75. PC_VDI: Outline fillable text, Includes Segmentation. Free Demo Disk. \$395.

Both products ANSI CGI compatible, drivers for printer, plotter, HP laser. CGA/EGA/VGA. For most "C" compilers, MS FORTRAN, QuickBASIC. Demos, manual.

NOVA, INC.

P.O. BOX 68976, Schaumburg, IL 60168
312-882-4111

Inquiry 744.

LOGGER®

Logger, for IBM-PC and compatibles, tracks and reports: User, Time on, Time off, Directories used, Programs used, Program start/end time, and calculates totals. Tracks directories/files: Opened, Created, Renamed, Deleted. Completely transparent. Retail for \$74.95 with quantity discounts available.

System Automation Software, Inc.

8555 16th St., Silver Spring, MD 20910
1-800-321-3267 or 1-301-565-8080

Inquiry 747.

PC-Write 3.0 — Shareware

Fast, full featured word processor for IBM PC. Now edits large files & multiple columns. Also spell check, mailmerge, networking, ASCII, and macros. Easy to use, optional menus. Supports 500 printers incl. lasers. Software, guide and tutorial on disk: \$16. Registration with manual, support newsletter and 2 free updates: \$89.

90 day money back guarantee. VISA/MC.

Quicksoft

1-800-888-8088

219 First Ave. N., #224-BYTC, Seattle, WA 98109

Inquiry 751.

TO PLACE YOUR AD IN

THE BUYER'S MART

CALL BRIAN HIGGINS AT 603-924-3754

PC COMPATIBLE ENGINEERING

Annabooks gives you the hardware, software, and firmware information you need to design PC-compatible systems faster and better. And you have control of your design from the ground up -- our firmware and software products include source code! Plus all the utilities you need.

Do hardware design? **Reactor Design's** 1M DRAM SuperSpec is the first of a series of hardware books you won't want to miss. And a PC Bus timing book is on the way! Start by getting these books:

AT BiosKit: an AT Bios with source code you can modify. With setup & debug. 380 pages with disk, \$199

XT BiosKit: Includes a debug. 270 pages with disk, \$99

Intel Wildcard Supplement for XT BiosKit: Includes ASIC setup, turbo speeds, 60 pages with disk, \$49

1M DRAM SuperSpec: Design your memory to all mfg's specs at once! Lots of timing diagrams & tables, \$79

PromKit: Puts anything in Eprom or SRAM; DOS, your code, data, you name it! With source on disk, \$179

SysKit: Here's a debug/monitor you can use even with a brand X Bios. Includes source, of course. \$69

XT-AT Handbook: The famous pocket-sized book jam-packed with hardware & software info. \$9.95 ea. or 5 or more for \$5 each.

Software tools: You need MS C & MASM 5.1 for modifying the Kit products.

FREE Mention this ad when you order and get a free XT-AT Handbook by Choissar & Foster! Hurry before we come to our senses and change our minds.

Annabooks

12145 Alta Carmel Ct Suite 250-262
San Diego, California 92128

(619) 271-9526 Money-back guarantee



STREAMING TAPE BACKUP

ONLY
\$249

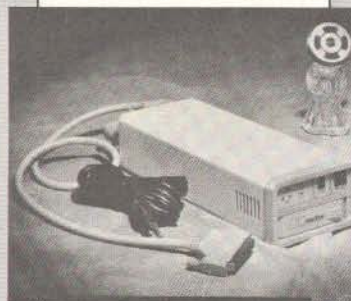

External Tape Subsystem for PC ATs/XTs

- InterDyne 20MB streaming tape drive
- Advanced file-by-file backup software
- External subsystem with its own power supply
- Complete system includes everything you need

**Order
Today!**

1-800-637-7878

"Ask about our money-back guarantee."



100 Rancho Road #27,
Thousand Oaks, CA

IBM, PC, and AT are registered trademarks of International Business Machines.

Ventura

Peripherals

SUBSCRIPTION PROBLEMS?



We want
to
help!

If

you have a problem with your BYTE subscription, write us with the details.

We'll do our best to set it right. But we must have the name, address, and zip of the subscription (new and old address, if it's a change of address). If the problem involves a payment, be sure to include copies of the credit card statement, or front and back of cancelled checks. Include a "business hours" phone number if possible.

BYTE MAGAZINE

ATTN: SUBSCRIBER SERVICE
P.O. Box 555
HIGHTSTOWN, NJ 08520



2400 bps MODEM \$95 30 DAY FREE TRIAL
2400 - 4800 bps MNP-5...CALL

Many low cost modems are faulty or very error prone... **Not ours!!!**
PERFORMANCE "I have recently had a lot of trouble getting 2400 BAUDMODEMSto work...this one is working perfectly." R.T., Moreno Valley CA. **SUPPORT** "I get the impression that your company, indeed, bends over backwards to provide service to its customer." M.F., Selma CA. **SUPERIOR TECHNOLOGY...**The phone connection is the main source of data errors. **DYNAMIC IMPEDANCE STABILIZATION, DIS** (invented by CompuCom) improves signal quality and reduces these errors by up to 95% compared to a standard modem. Model 2400 (without DIS) at \$95 outperforms the low cost alternatives, the 24DIS at \$119 outperforms the challengers, regardless of cost. IBM internal, Hayes compatible, made in USA, 6 COM ports, internal speaker, five year warranty, EasyCom software, dealers inquire. *If you aren't totally satisfied, return within thirty days for a full refund!*

March '89 p102 **BYTE MAGAZINE**
CompuCom Corporation "Real deal...worked fine...quite a bargain!"
CALL (408) 732-4500 (800) 228-6648

Save Your Data and Money, Too! Peripherals Sale!

Easy to Install!



Up to 150MB Capacity.

This is the fastest floppy interface tape drive around!
60MB TAPE DRIVES

Add \$10 for Shipping **\$279** 40MB Tape \$22
60MB Tape \$30

External model now available for only \$99 extra!

Works on PC, XT, AT's and 100% compatibles. Connects to the internal floppy (B:) connector or the optional adapter card (\$77). Comes complete with

installation instructions and data compression software that allows up to 100MB data storage on a 40MB tape — 150MB on a 60MB tape.



Total Power Protection!

UNINTERRUPTABLE POWER SUPPLY

As Low As **\$279** 250 Watt Model
Add \$23 shipping in the lower 48 states.

250 Watt	120 Volt	\$ 279
300 Watt	120 Volt	399
500 Watt	120 Volt	499
600 Watt	120 Volt	639
1200 Watt	120 Volt	1099
1600 Watt	120 Volt	1444*

230 volt units also available. *Shipped motor freight collect. Specify exact input voltage.

- Protects Against**
- Brownouts.
 - Blackouts.
 - Overvoltage.
 - Overload.
 - Spills/Surges
 - EMI

- Features**
- Two Audible Alarms.
 - LED Displays.
 - Optional Network Port.
 - Transfer Times As Fast As 1 Millisecond (Depends on Model).

Limited Time Only! Fantastic Prices Now On LOW COST HARD DRIVES For IBM and Tandy



Get the Best for Less!

Add \$10 for shipping.

5.2MB 95ms ST-506 MFM XT Kit **\$149**

21.4MB 65ms ST-225 MFM XT Kit **\$259**

32.7MB 65ms ST-238 12LL XT Kit **\$289**

42.8MB 40ms ST-251 MFM XT Kit **\$399**

\$399 49.1MB 40ms ST-157R RLL Bare 28ms Optional

\$479 65.5MB 40ms ST-277R RLL XT Kit 28ms Optional

\$599 80.2MB 28ms ST-4096 MFM Bare

\$599 84.9MB 28ms ST-296N SCSI Kit

\$699 122.7MB 28ms ST-144R RLL Bare

We provide the best low cost, high quality, fast access hard drives for your IBM, 100% compatible or Tandy computer. Our XT and SCSI kits are complete with drive, controller, cables and installation instructions. We use only brand new genuine Seagate drives so you can be assured of long trouble-free drive life. Data transfer rates as fast as 500KB per second MFM, 800KB RLL and 1MB using SCSI.

We provide software to park the heads (some drives self-park). Tandy 1000 requires DMA and ROM 1.01+. Not for EX/HX. Please specify the computer brand and model when ordering. ST 506, 4096 and 4144R are full size 5 1/2", ST 157R is 3 1/2". All others are half height 5 1/4". Sizes listed are after formatting. One year parts and labor warranty. Satisfaction guaranteed or your money back, less shipping.



Hurry! Supply Limited

Save on 32MB & 49MB Hard Cards

32.7MB 48ms RLL **\$329** 49.1MB 40ms RLL **\$489**

These units are completely assembled with brand new drives and come ready to install. For IBM XT's, 100% compatibles and Tandy 1000/1000A, SL, SX, TL, TX. Please specify the exact make and model of your computer. One year parts and labor warranty.

Save on Low Cost Floppys!

Select the drive or drives you want, pick the enclosure and appropriate cable and we will assemble and test at no additional cost to you. All drives are brand new, not factory seconds, and carry a full one year parts and labor warranty. Add \$5 shipping and handling per drive.

360K 5.25" TEAC 55B bare	\$ 79
720K 5.25" TEAC 55F bare	85
1.2M 5.25" TEAC 55FGH bare	85
360K 3.5" TEAC 35B bare	119
720K 3.5" TEAC 35F bare	85
1.44M 3.5" TEAC 35FGH bare	85
5.25" mounting bracket for 3.5" drives	18

(Includes rails, signal & power adapter. Specify beige or black faceplate)

Dual 3.5" external case/power supply. Use with one or two 3.5" drives (horizontal)	\$49
Dual 5.25" same as above except vertical	59
IBM external floppy cable for C/D. DB37 required	39

(Add \$10 for brushed Stainless Steel cover)

SOFTWARE SPECTACULAR! SENSATIONAL SAVINGS!

This list is only a small portion of our inventory! Call us for your software needs!

MS-DOS® BUSINESS SOFTWARE

Allways	\$ 92
Borland Quattro (1-2-3 Clone)	169
Borland Sprint: The Work Processor	138
DAC Easy Accounting (all version 3)	61
DAC Easy Bonus Pack	123
DAC Easy Payroll	61
dBase III Plus	439
dBase IV	499
Desqview	79
Desqview 386	116
Formtool	55
Framework III	399
Generic Cadd, Level 1	28
Generic Cadd, Level 2	55
Harvard Graphics	299
Lotus 1-2-3 2.01	319
Pagemaker 3.0	134
Peachtree Complete System II	174
pfs: First Choice	99
pfs: First Publisher	83
pfs: Professional File with Report	169
pfs: Professional Plan	62
pfs: Professional Write	125
Printshop Bundle	37
Printshop Companion	31
Publish It!	122
Q & A	229

Quicken	\$ 31
Rightwriter	52
Ventura Publisher 2.0	529
WordPerfect 5.0	255
WordStar Pro Release 5	248

OTHER MS-DOS SOFTWARE

Chess Master 2100	\$32
F-19 Stealth Fighter	43
Kings Quest I, II, III or IV	31
Leisure Suit Larry	26
Leisure Suit Larry II	30
Managing Your Money	129
Mavis Beacon Teaches Typing	33
Math Blaster Plus	28
Microsoft Flight Simulator	37
Reader Rabbit	26
Test Drive	22
Typing Tutor IV	31
Where in Europe is Carmen San Diego?	28
Where in U.S.A. is Carmen San Diego?	28
Where in World is Carmen San Diego?	25

MS-DOS LANGUAGES/UTILITIES

AutoSketch	\$ 53
Borland Sidekick Plus	138
Borland Turbo BASIC	69
Borland Turbo C	104
Borland Turbo PASCAL with 8087/BCD	103
Carbon Copy + (need two copies)	119
Copy II PC	21

Copy II PC Option Board Deluxe	\$116
Fastback Plus	115
Grammatik III	54
Laplink Plus	84
Microsoft Macro Assembler 5.1	99
Microsoft Quick BASIC Compiler	67
Microsoft Quick "C" Compiler	67
Microsoft Windows 286	67
Microsoft Windows 386	133
Norton Utilities 4.5 Advanced	79
PC Tools Deluxe 5.0 Advanced	45
Procomm Plus	46
Sideways	42
X Tree Pro	69

BOOKS

Take advantage of our volume discounts and save a bundle! Buy any 3 books and earn an additional \$3 discount. Buy 4 and deduct \$4. Buy 5, deduct \$5, etc.

Using 1-2-3, Special Edition	\$19
dBase III Plus Handbook	17
dBase IV Handbook	16
Managing Your Hard Disk	16
MS-DOS Users Guide 3rd Edition	17
Running MS-DOS	17
Using AutoCad	21
Using Managing Your Money	15
Using Paradox	17
Using Q & A	16
Using WordPerfect 4.2	16
Using WordPerfect 5	19

Clone emolD

Reg. U.S. Pat. Off.



ORDER TOLL FREE!

Mon.- Fri. 9-7; Sat. 10-3

Call from anywhere in the lower 48 states and Hawaii.

1-800-527-0347



AD P3

HIGH QUALITY..LOW PRICE!

We've Built Our Reputation on This Premise for Almost a Full Decade.

Clone 286 With
LOW PRICE

\$1299

Complete System!

10MHz, 30MB HARD DRIVE, MONOCHROME MONITOR

Clone 286 With
MEDIUM SPEED

\$1969

12MHz, 40MB HARD DRIVE, EGA MONITOR

Clone 286 With
HIGH SPEED

\$2429

16MHz, 65MB HARD DRIVE, VGA MONITOR

VGA Color!

Standard Features of All Clone 286 Computers:

- 640K / 1MB RAM Standard (see chart).
- I:1 Interleave, 2 Floppy/2 Hard Disk Controller (798 Kb/s RLL, 535 Kb/s MFM).
- 360K, 1.2M or 1.44M (3.5") Floppy Drive (your choice).
- 101 Key Enhanced Keyboard (Click-Tactile Option add \$20).
- 1 Parallel, 1 Serial, 1 Joystick Port.
- 200 Watt Power Supply.
- On-Board Clock/Calendar with Battery Backup.
- FCC Certified.
- System Reset Switch Located on the Front Panel.
- Setup in ROM.
- 80287 Math Coprocessor Socket.
- CPU Speed Switchable.
- Fully Expandable.
- Novell Compatible.
- One Year Parts and Labor Warranty.
- PC-Write - QModem - ExpressCalc AutoMenu - HomeBase - Money Master - Findex - Clone Utilities.



GUARANTEED One year parts and labor. 30 day money back guarantee (except software).

SERVING YOU SINCE 1980

CLONE VALUE CHART		HERC MONO	VGA MONO	CGA COLOR	EGA COLOR	VGA COLOR
12MHz 640K RAM 1 WATT STATE	32MB RLL 65ms	\$1299	\$1579	\$1459	\$1719	\$1879
	42MB MFM 40ms	1399	1679	1559	1819	1979
	65MB RLL 40ms	1499	1779	1659	1919	2079
	122MB RLL 28ms	1799	2079	1959	2219	2379
12MHz 1MB RAM 0 WATT STATE	32MB RLL 65ms	\$1449	\$1729	\$1609	\$1869	\$2029
	42MB MFM 40ms	1549	1829	1709	1969	2129
	65MB RLL 40ms	1649	1929	1809	2069	2229
	122MB RLL 28ms	1949	2229	2109	2369	2529
16MHz 1MB RAM 0 WATT STATE	32MB RLL 65ms	\$1649	\$1929	\$1809	\$2069	\$2229
	42MB MFM 40ms	1749	2029	1909	2169	2329
	65MB RLL 40ms	1849	2129	2009	2269	2429
	122MB RLL 28ms	2149	2429	2309	2569	2729



MEMBER DIRECT MARKETING ASSOCIATION MEMBER MMC MICROCOMPUTER MARKETING COUNCIL

OPTIONAL EQUIPMENT FOR CLONE COMPUTERS

MODEMS & RODENTS

- Logimouse with software, Bus or Serial \$ 75
- Hi-REZ Logimouse with software, Bus 94
- Logimouse with First Publisher 108
- Hi-REZ Logimouse with First Publisher, CADD and Paint Show Plus 177
- Microsoft Mouse w/software, Bus or Serial 108
- Microsoft Mouse with Windows 286 149
- C+H Mach III Joystick 32
- C+H Flight Stick 50
- 1200 Baud internal modem with software 59
- 2400 Baud internal modem with software 99

ADD-ONS & ACCESSORIES

- Autoswitching Hercules graphics/color graphics video card w/printer port, smooth scroll \$ 49
- Generic EGA card. 640 x 350 resolution 159
- Generic VGA card. 640 x 480 resolution 259
- Math coprocessors. All types, speeds in stock.
- Printer switch box, 2-position. 25 or 36 pin 29
- Printer switch box, 4-position. 25 or 36 pin 39
- 25 pin cable, 10', Molded ends. MM or MF 16
- 36 pin cable, 10', Molded ends. MM or MF 20
- Vertical CPU stand. Add \$9 for wheels 24
- AST Rampage 2MB EEMS memory board for

- ATs. Comes with 512K RAM \$ 439
- Masterpiece Plus power director. Includes modem protection 119
- The Complete Fax 9600 449
- The Complete Answering Machine Board 227
- The Complete Hand Scanner (400 DPI) 162
- The Complete Half-page Scanner 195
- Logitech ScanMan (400 DPI) 219

PRINTERS

- Star NX-1000 144cps, NLQ \$179
- Star NX-1000 Rainbow, as above w/color 239
- Star NX-15 120/30 cps NLQ, wide 319
- Star ND-15 180/45 cps 389
- Star NR-10 240/80 cps NLQ 349
- Star NR-15 as above with wide carriage 449
- Star NB-15 300/100 cps NLQ 759
- Star NB24-10 216/72 cps LQ 469
- Star NB24-15 as above with wide carriage 579
- Star NX-2400 170/57 cps LQ 24, pin 359
- Panasonic KX-P1124, 80/192 cps, 24 pin 359
- Panasonic KX-P1191, 80 col/120 cps 269
- Panasonic KX-P1180, 80 col/144 cps 219
- Panasonic KX-P1092, 80 col/240 cps 329
- IBM parallel printer cable, molded ends 12

Buy with Confidence! Our Guarantee Removes All the Risk from Your Buying Decision!

The Clone Guarantee is simple and straightforward. You have 30 days after receipt of your Clone to see if you and it are going to be compatible. If you are not satisfied with your Clone for any reason within that time, you may return it for a full refund, less shipping charges. Just don't write in the manuals and damage or lose anything that was in the original container, which also must be returned. You can void your warranty by failing to exercise normal care when hooking up or operating your Clone. Complete warranty details are available on request.



TURBO CLONE

AT Style Keyboard **\$749** Save Now!

- Standard Features:
- 8088 @ 4.77 - 10MHz Turbo-speed Mainboard.
 - 640K RAM standard.
 - 8087 Socket.
 - 150 Watt Power Supply.
 - 360K Floppy Drive with Disk Controller.
 - Hercules® Compatible Video Card.
 - Hi-Resolution TTL Monitor (choose green or amber)
 - 2-Parallel Printer Ports.
 - 1-Serial Port (2nd Optional at \$29).
 - Game-Joystick Port.
 - Clock/Calendar with battery backup.
 - 8 Slots.
 - Fully Expandable.
 - Mom's ROM BIOS.
 - PC-Write - QModem ExpressCalc - HomeBase MoneyMaster - Findex Clone Utilities - AutoMenu.



- FCC Class B Certified.
- Keyboard Lock.
- System Hardware Reset Switch on Front Panel.
- LED's for Power, Turbo and Hard Disk Access.
- One Year Parts and Labor Warranty.

NO ORPHANED CUSTOMERS

We have been supplying customers with high quality hardware and software since 1980. Sound engineering, high performance, quality construction, outstanding warranties and a reputation for doing the right thing have been our way of doing business since Day One. As the manufacturer of Clone Computers, we stand behind each computer sold with a 100% commitment to our customer's satisfaction. Price, Performance, Value...Clone is the clear choice for serious computer users. Remember...YOUR BEST FRIEND MAY BE A CLONE.



CLONE COMPUTERS • 2544 W. Commerce St. • Box 223957
Dallas, Texas 75222-3957 • Telex: 882761 • Fax: 214-634-8303

For information or technical assistance call 214-637-5400

©1989 by Clone Computers. All rights reserved. Prices and specifications subject to change without notice. All prices are in U.S. Dollars. Payments must be in U.S. funds drawn on a U.S. bank.

Clone smolD

Reg. U.S. Pat. Off.

JUNE 1989 • B Y T E 351

NEC V20 & V30 CHIPS

Replace the 8086 or 8088 in Your IBM PC and Increase its Speed by up to 30% Price

Part No.	1-9	10+	Part No.	1-9	10+
UPD70108-5 (5MHz) V20 Chip	\$7.49	\$6.49			
UPD70108-8 (8MHz) V20 Chip	\$9.49	\$7.95			
UPD70108-10 (10MHz) V20 Chip	\$12.95	\$10.95			
UPD70116-8 (8MHz) V30 Chip	\$9.95	\$7.95			
UPD70116-10 (10MHz) V30 Chip	\$14.95	\$11.49			

7400

Part No.	1-9	10+	Part No.	1-9	10+
7400	SALE	15	7474	SALE	25
7402	29	19	7475	49	39
7404	SALE	15	7476	45	35
7405	35	25	7483	69	59
7406	39	29	7485	SALE	45
7407	SALE	25	7486	SALE	29
7408	35	25	7489	1.95	1.85
7410	SALE	15	7490	49	39
7411	35	25	7493	45	35
7414	SALE	25	7495	59	49
7416	19	14	74107	25	15
7417	SALE	19	74121	SALE	25
7420	29	19	74123	SALE	35
7427	29	19	74125	SALE	35
7430	SALE	15	74147	1.79	1.69
7432	39	29	74150	SALE	1.10
7438	29	19	74151	25	15
7442	SALE	29	74154	1.35	1.25
7445	SALE	59	74161	69	59
7446	89	79	74173	SALE	59
7447	89	79	74174	SALE	35
7448	1.95	1.85	74175	SALE	35
7473	39	29	74193	79	69

74LS

Part No.	1-9	10+	Part No.	1-9	10+
74LS00	SALE	15	74LS139	SALE	29
74LS02	SALE	15	74LS141	49	39
74LS03	28	18	74LS153	49	39
74LS04	SALE	16	74LS154	1.19	1.09
74LS05	SALE	16	74LS157	45	35
74LS06	59	49	74LS161	49	39
74LS07	59	49	74LS163	SALE	35
74LS08	28	18	74LS174	SALE	45
74LS09	28	18	74LS165	75	65
74LS10	SALE	15	74LS166	SALE	69
74LS11	29	19	74LS173	SALE	25
74LS14	SALE	29	74LS174	SALE	25
74LS20	28	18	74LS175	SALE	25
74LS21	35	25	74LS191	SALE	35
74LS27	SALE	19	74LS192	69	59
74LS30	SALE	15	74LS193	69	59
74LS32	SALE	19	74LS194	69	59
74LS38	35	25	74LS221	SALE	49
74LS42	49	39	74LS240	SALE	45
74LS47	89	79	74LS241	59	49
74LS53	SALE	19	74LS267	SALE	49
74LS74	SALE	19	74LS245	SALE	59
74LS75	SALE	25	74LS257	49	39
74LS76	39	29	74LS259	99	89
74LS83	59	49	74LS273	89	79
74LS85	59	49	74LS279	49	39
74LS86	29	19	74LS374	SALE	29
74LS90	SALE	29	74LS373	SALE	59
74LS93	SALE	29	74LS374	SALE	49
74LS123	SALE	35	74LS393	SALE	69
74LS125	49	39	74LS541	1.29	1.19
74LS132	49	39	74LS590	5.95	5.85
74LS138	49	39	74LS688	2.39	2.29

74S/PROMS*

Part No.	1-9	10+	Part No.	1-9	10+
74S00	SALE	19	74S188*	1.49	
74S04	SALE	19	74S189	1.49	
74S32	SALE	19	74S240	1.39	
74S74	SALE	19	74S244	SALE	75
74S112	39	29	74S287*	1.49	
74S124	SALE	1.25	74S288*	1.49	
74S138	59	49	74S373	SALE	99
74S153	39	29	74S420	SALE	99
74S163	39	29	74S387*	SALE	1.29
74S174	SALE	25	74S472*	SALE	2.49
74S175	SALE	25	74S571*	2.49	

CD-COMOS

Part No.	1-9	10+	Part No.	1-9	10+
CD4001	19	14	CD4051	59	
CD4002	19	14	CD4052	59	
CD4007	25	20	CD4053	59	
CD4011	19	14	CD4060	65	
CD4012	25	20	CD4066	25	
CD4015	29	24	CD4069	19	
CD4016	29	24	CD4070	29	
CD4017	49	39	CD4071	22	
CD4018	59	49	CD4072	22	
CD4020	59	49	CD4081	22	
CD4021	59	49	CD4093	35	
CD4024	45	35	CD4094	89	
CD4027	35	25	CD4095	39	
CD4028	49	39	CD4511	69	
CD4029	69	59	CD4518	75	
CD4030	35	25	CD4520	75	
CD4040	65	55	CD4522	79	
CD4042	59	49	CD4528	69	
CD4043	59	49	CD4538	79	
CD4046	65	55	CD4543	79	
CD4047	65	55	CD4548	69	
CD4049	29	19	CD4585	49	
CD4050	29	19			

EEPROMS

Part No.	1-9	10+	Part No.	1-9	10+
2816A	2048x8	350ns (9V-15V) 5V Read/Write	5.25		
2816A-25	2048x8	250ns (9V-15V) 5V Read/Write	5.49		
2817A	2048x8	350ns 5V Read/Write	6.95		
2864A	8192x8	250ns 5V Read/Write (Pin 1 No. R1) 13.95			
2864A-30	8192x8	300ns 5V Read/Write (Pin 1 No. R1) 12.95			
2865A-30	8192x8	300ns 5V Read/Write	9.95		
52B13	2048x8	350ns (21V) 5V Read Only	1.49		

MICROPROCESSOR COMPONENTS

Z80, Z80A, Z80B, SERIES

Part No.	Price	Part No.	Price
Z80	1.19	8155-2	3.49
Z80A	1.29	81C55	3.95
Z80A-CTC	1.65	8156	2.95
Z80A-DART	4.95	8205	3.95
Z80A-PIO	1.89	8211	6.95
Z80A-SIO	2.95	8212	2.29
Z80B	2.75	8216	1.39
Z80B-CTC	3.95	8224	2.26
Z80B-PIO	3.95	8228	1.96
Z80B81B1	9.96	8237.5	4.26

8000 SERIES

Part No.	Price	Part No.	Price
80031	0.96	8250A	4.96
80031	0.96	8250B (For IBM)	5.96
80035	1.96	8251A	1.69
80039	1.96	8253	1.89
8052AHBASIC	24.95	8253.5	3.95
8080A	2.26	8254	3.95
8085A	2.49	8255A-5	2.95
8085A-2	3.59	8255A-5	3.49
8087 (5MHz)	99.96	8259-5	2.26
8087-1 (10MHz)	184.95	8272	3.95
8087-2 (8MHz)	134.95	8274	5.95
8088 (5MHz)	4.95	8279-5	2.95
8089-2 (8MHz)	6.95	8282	3.49
8116	4.95	8284	1.29
8155	2.49		

STATIC RAMS

Part No.	Function	Price
2016-12	2048x8 120ns	3.76 2.95
2102	1024x1 350ns	89
2112	256x4 45ns MOS	2.49 1.95
2114N	1024x4 45ns	99 79
2114N-2L	1024x4 200ns Low Power	1.49
21C14	1024x4 200ns (CMOS)	2.96 2.49
5101	256x4 45ns (CMOS)	2.96 2.49
6116P-1	2048x8 100ns (16K) CMOS	3.96 3.19
6116P-3	2048x8 150ns (18K) CMOS	3.49 2.79
6116LP-1	2048x8 100ns (16K) LP CMOS	4.49 3.59
6116LP-3	2048x8 150ns (18K) LP CMOS	3.96 3.09
6264P-10	8192x8 150ns (64K) CMOS	9.96 7.95
6264P-15	8192x8 150ns (64K) CMOS	9.26 7.49
6264LP-10	8192x8 120ns (64K) LP CMOS	10.49 8.25
6264LP-12	8192x8 120ns (64K) LP CMOS	10.49 8.25
6264LP-15	8192x8 150ns (64K) LP CMOS	10.26 7.95
6514	1024x4 350ns CMOS	3.76 3.49
42256-10L	32 768x8 100ns (256K) Low Power	26.95
42256-15L	32 768x8 150ns (256K) Low Power	25.95
62256LP-8S	32 768x8 85ns (256K) LP CMOS	29.95
62256LP-10	32 768x8 100ns (256K) LP CMOS	27.95
62256LP-12	32 768x8 120ns (256K) LP CMOS	27.25

DYNAMIC RAMS

Part No.	Function	Price
THM91000L-10	1 048 576x9 100ns 1MEGx9 SIP	399.96 329.95
THM91000S-10	1 048 576x9 100ns 1MEGx9 SIM	399.96 329.95
THM91000L-80	1 048 576x8 80ns 1MEGx8 SIP	419.96 349.95
THM91000S-80	1 048 576x8 80ns 1MEGx8 SIM	419.96 339.95
TMS4416-12	16 384x4 120ns	6.76 5.95
TMS4416-15	16 384x4 150ns	6.26 5.49
4128-15	16 384x1 150ns (MMS290N-2)	1.99
4128-15	16 3107x1 150ns (Piggyback)	5.49
4164-100	65 536x1 100ns	2.95
4164-120	65 536x1 120ns	2.95
4164-150	65 536x1 150ns	2.95
41256-60	262 144x1 60ns	14.99 10.99
41256-80	262 144x1 80ns	16.19 18.95
41256-100	262 144x1 100ns	9.76 8.49
41256-120	262 144x1 120ns	8.66 7.95
41256-150	262 144x1 150ns	8.49 7.49
41264-12	64Kx4 120ns Video RAM	19.95
41464-10	65 536x4 100ns	14.49 11.95
41464-12	65 536x4 120ns	14.49 9.95
41464-15	65 536x4 150ns	14.96 9.95
51256-100	262 144x1 100ns Static Column	13.96
85227-10PS	262 144x9 100ns 256x9 SIP	149.96 105.95
85227-10PS	262 144x9 100ns 256x9 SIM	149.96 105.95
511000P-10	1 048 576x1 100ns (1 Meg)	26.96 21.95
511000P-80	1 048 576x1 80ns (1 Meg)	26.96 24.95
514256P-10	262 144x4 100ns (1 Meg)	34.96 29.95
514256-10	262 144x4 100ns Static Column	31.95

EPROMS

Part No.	Function	Price
TMS2516	2048x8 450ns (25V)	6.96 5.95
TMS2532	4096x8 450ns (25V)	6.96 4

TEST EQUIPMENT

Metex Digital Multimeters

Metex General Specs:
• Handheld, high accuracy
• AC/DC Voltage, AC/DC Current, Resistance, Diodes, Continuity, Transistor hFE • Manual ranging w/overload protection
M3650/B & M4650 only:
• Also measures frequency and capacitance
M4650 only:
• Data Hold Switch
• 4.5 Digit



M4650 Pictured

M3610	3.5 Digit Multimeter.....	\$49.95
M3650	3.5 Digit w/Freq. & Capacitance.....	\$69.95
M3650B	Same as M3650 w/Bargraph.....	\$79.95
M4650	4.5 Digit w/Freq., Capacitance and Data Hold Switch.....	\$99.95

Metex Autoranging Jumbo Readout DMM

• AC/DC Voltage, AC/DC Current, Resistance, Diodes, Continuity and Frequency • 3.75 Digit (.8" High)
• Ruggedized, Water-resistant case
• Easy-to-use pushbutton switches



M80.....\$59.95

COMPUTER ACCESSORIES

DFI Handy Scanner and 3 Button Xite for IBM PC/XT/AT

FREE DPE Software with HS3000!



HS3000 Pictured

The HS3000 offers a full 4 inch window at 400dpi resolution. Scan photos, logos, drawings, etc. Can be used with today's most popular applications.

HS3000	Handy Scanner.....	\$199.95
DMS200	200DPI 3-Button Ser. Mouse.....	\$49.95
DMS200S	200DPI 3-Button Ser. Mouse with Dr. Halo Software.....	\$59.95

IBM Compatible Cases and Power Supplies



JE2010 Pictured

JE1030	Pictured	
JE1010	Flip-Top Standard PC/XT Case.....	\$34.95
JE1017	Flip-Top Baby AT Case.....	\$69.95 \$54.95
JE1018	Slide Baby AT Case.....	\$69.95 \$59.95
JE1030	150 watt PC/XT Power Supply.....	\$59.95
JE1032	200 watt Baby AT Power Supply.....	\$89.95
JE2010	Tower Case w/250 watt Pwr. Supply.....	\$279.95
JE2014	Flip-Top Baby XT Turbo Case.....	\$69.95

2400/1200/300 Baud Modems

Datronics

• Hayes command compatible
• Bell 103/212A compatible
• Auto-dial/auto-answer • FCC approved • 1-year warranty • Includes MaxiMite Communication Software (except 1200P)



1200P	1200/300 Baud Pocket Size Modem.....	\$99.95
1200H	1200/300 Baud Internal Modem.....	\$69.95
2400H	2400/1200/300 Baud Internal Modem.....	\$129.95
1200C	1200/300 Baud External Modem.....	\$99.95
2400C	2400/1200/300 External Modem.....	\$169.95

Jameco 12MHz IBM AT Compatible Kit With 512K RAM

- Free! QAPLUS Diagnostic Software Included!
- Free! PC Write Word Processing Software Included!
- 512K RAM Included, Expandable to 4MB
- AMI BIOS ROMs Included
- 8 or 12MHz Operation
- Regular \$832.52 value for only \$699.95!
- Flip-Top Case w/200 Watt Power Supply
- 1.2MB Disk Drive
- 13.7 Norton SI Rating
- 101-Key (Enhanced) Keyboard



Shown with EGA Option (not included)
JE1059 Monitor and Adapter Card \$499.95 (See Below)

JE3008	12MHz IBM AT Comp. Kit.....	\$799.95 \$699.95
EZDOS	Digital Research MS/PC-DOS Comp. Operating Sys.....	\$49.95
EZDOSP	Same as above with TrueBASIC.....	\$69.95

IBM COMPATIBLE DISPLAY MONITORS

AMBER	12" Amber Mono.....	\$99.95
HD55H	14" RGB 640x240.....	\$249.95
TM5154	EGA 14" 720x350.....	\$399.95 \$369.95
JE1059	EGA Monitor & Card.....	\$619.95 \$499.95
TM5155	14" Multiscan 800x560.....	\$649.95 \$499.95
QC1478	14" VGA 720x480.....	\$449.95 \$399.95
JE2055	VGA Monitor & Card.....	\$649.95 \$599.95



QC1478 Pictured

JAMECO IBM PC/XT/AT COMPATIBLE CARDS

JE1041	20/40MB Hard Disk Controller Card (PC/XT).....	\$79.95
JE1043	360K/720K/1.2MB/1.44MB Floppy Disk Controller Card (PC/XT/AT).....	\$49.95
JE1044	360K/720K/1.2MB/1.44MB Floppy/Hard Disk Controller Card (PC/XT).....	\$129.95
JE1045	360K/720K/1.2MB/1.44MB Floppy/Hard Disk Controller Card (AT).....	\$149.95
JE1050	Monochrome Graphics Card w/Parallel Printer Port (PC/XT/AT).....	\$59.95
JE1052	Color Graphics Card w/Parallel Printer Port (PC/XT/AT).....	\$49.95
JE1055	EGA Card w/256K Video RAM (PC/XT/AT).....	\$159.95
GC1500	Orchid 8-Bit VGA Card w/256K Video RAM (PC/XT/AT).....	\$269.95 \$249.95
GC1501	Orchid 8/16-Bit VGA Card w/256K Video RAM (PC/XT/AT).....	\$349.95 \$329.95
JE1060	I/O Card w/Serial, Game, Printer Port & Real Time Clock (PC/XT).....	\$59.95
JE1061	RS232 Serial Half Card (PC/XT).....	\$29.95
JE1062	RS232 Serial Half Card (AT).....	\$34.95
JE1065	I/O Card w/Serial, Game and Parallel Printer Port (AT).....	\$59.95
JE1071	Multi I/O Card w/Controller & Monochrome Graphics (PC/XT).....	\$119.95
JE1081	2MB Expanded or Extended Memory Card (zero-K on-board) (AT).....	\$119.95

SEAGATE HALF-HEIGHT HARD DISK DRIVES

ST225	20MB Drive only (PC/XT/AT)	\$224.95
ST225XT	20MB w/Controller (PC/XT)	\$269.95
ST225AT	20MB w/Controller (AT)	\$339.95
ST238	30MB Drive only (PC/XT/AT)	\$249.95
ST238XT	30MB w/Controller (PC/XT)	\$299.95
ST238AT	30MB w/Controller (AT)	\$389.95
ST251	40MB Drive only (PC/XT/AT)	\$379.95
ST251XT	40MB w/Controller (PC/XT)	\$419.95
ST251AT	40MB w/Controller (AT)	\$489.95
ST251-1	40MB Fast 28ms (Drive only)	\$469.95

Your One-Stop Center for Hard Disk Drive Needs!



ST225XT Pictured

Seagate 60MB Hard Disk Drives Also Available!

IBM PC/XT/AT COMPATIBLE MOTHERBOARDS

JE1001	4.77/8MHz (PC/XT)	\$89.95
JE1002	4.77/10MHz (PC/XT)	\$109.95 \$99.95
JE3005	Baby 8/12MHz (AT)	\$329.95 \$299.95
JE3010	Baby 8/16MHz NEAT (AT)	\$469.95 \$399.95
JE3020	Baby 16MHz 80386 (AT)	\$1199.95
JE3025	Baby 20MHz 80386 (AT)	\$1499.95
JE3026	Full-Size 25MHz 80386 (AT)	\$2299.95

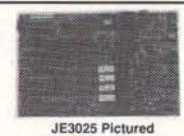

JE3025 Pictured

IBM PC/XT/AT COMPATIBLE 3.5" 5.25" DISK DRIVES

352KU	3.5" 720KB (PC/XT/AT)	\$109.95
356KU	3.5" 1.44MB (PC/XT/AT)	\$129.95
JE1020	5.25" 360KB (PC/XT/AT) Black	\$89.95
JE1021	5.25" 360KB (PC/XT/AT) Beige	\$89.95
JE1022	5.25" 1.2MB (PC/XT/AT) Beige	\$99.95



JE1022 Pictured

SUPER SONY SALE

720KB 3.5" Floppy Drive

• For use with IBM PC/XT/AT and compatible computers • Double-sided, double density • 135TPI • 160 tracks • Rotation speed: 300rpm • Size: 4"W x 6"D x 1"H

MPF11.....\$79.95

PROTOTYPING PRODUCTS

Jameco Solderless Breadboards

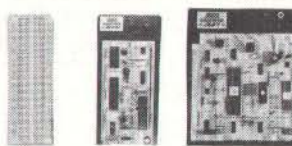

JE23 JE24 JE27

Part No.	Dim. L" x W"	Contact Points	Binding Posts	Price
JE21	3.25x2.125	400	0	\$4.95
JE23	6.5x2.125	830	0	\$7.95
JE24	6.5x3.125	1,360	2	\$12.95
JE25	6.5x4.25	1,660	3	\$19.95
JE26	6.875x5.75	2,390	4	\$24.95
JE27	7.25x7.5	3,220	4	\$34.95

COMPUTER ACCESSORIES

Jameco IBM PC/XT/AT Compatible Keyboards



JE2016 Pictured

JE1015	Standard AT Layout (PC/XT/AT).....	\$59.95
JE1016	Enhanced Layout (PC/XT/AT).....	\$69.95
JE2016	Enh. w/Solar Calculator (PC/XT/AT)....	\$79.95

Jameco Switch Boxes

• Female Connectors • All Pins Switched



JE1170 Pictured

Part No.	Description	Price
JE1170	DB25-pin A/B Switch.....	\$22.95
JE1171	DB25-pin A/B/C Switch.....	\$27.95
JE1172	DB25-pin A/B/C/D Switch.....	\$29.95
JE1173	Centronics36-pin A/B Switch....	\$24.95
JE1174	Centronics36-pin A/B/C Switch....	\$27.95

Viking 30MB Hard Disk Card for IBM PC/XT



SA30.....\$379.95

Colorado Memory 40MB Tape Back-Up for IBM PC/XT/AT

DJ10	40MB Tape Back-Up and Tape... \$349.95
TB40	40MB Tape Cartridge..... \$24.95

ENGINEERING/DATA BOOKS

21035	Sams TTL Cookbook (88)	\$14.95
21398	Sams CMOS Cookbook (88)	\$19.95
22453	Sams Op-Amp Cookbook (88)	\$21.95
270645	Intel 8-bit Controller Hndbk. (89)	\$19.95
270646	Intel 16-bit Controller Hndbk. (89)	\$19.95
270647	Intel 32-bit Controller Hndbk.(89)	\$19.95
400041	NSC Linear Data Book Vol 1 (88)	\$14.95
400042	NSC Linear Data Book Vol 2 (88)	\$9.95
400043	NSC Linear Data Book Vol 3 (88)	\$9.95

355 Shoreway Road
Belmont, CA 94002
24 Hour Order Hotline (415) 592-8097
FAX's (415) 592-2503 or (415) 595-2664
Telex 176043 - Ans. Back: Jameco Blmt
Data Sheets - 50¢ each
Send \$2.00 Postage for a FREE 48-Page Flyer
© 1989 Jameco Electronics 6/89
BM is a registered trademark of International Business Machines



\$20.00 Minimum Order - U.S. Funds Only
CA Residents Add 6%, 6.5% or 7% Sales Tax
Shipping - Add 5% plus \$1.50 Insurance (May vary according to weight)
Terms: Prices subject to change without notice. We are not responsible for typographical errors. We reserve the right to substitute manufacturers. Items subject to availability and prior sale. Products pictured may only be representative. Complete list of terms/warranties is available upon request.

24-Hour Order Hotline (415) 592-8097 • The Following Phone Lines Are Available From 7AM - 5PM P.S.T.:

• Customer Service (415) 592-8121 • Technical Assistance (415) 592-9990 • Credit Department (415) 592-9983 • All Other Inquiries (415) 592-7108

**SAME-DAY SHIPMENT!
MONEY-BACK GUARANTEE!**

**"RS-232C TO CURRENT LOOP
BI-DIRECTIONAL
CONVERTER"
Model 232CL2**

only **\$39.95**



Interface your RS-232 port to existing current loop system. Model 232CL2 couples and isolates Transmit and Receive Data through high speed optical isolators. Powered from pins 4, 5, 6, 8 and 20 on the RS-232 side; one pin must be high, one must be low.

No power required if current loop port is active. Model 232PS-12V DC Power Supply required if current loop port is passive; only \$14.95.

Order direct from manufacturer **TODAY and SAVE!**

Request your **FREE** copy of **B & B ELECTRONICS' Catalog** which lists a host of interface and monitoring equipment for RS-232 ports.



*Terms: Visa, MC, cash orders postpaid; P.O.'s from qualified rated firms accepted. IL residents add 6 1/4% sales tax.

B & B electronics
MANUFACTURING COMPANY

4002F Baker Road • P.O. Box 1040 • Ottawa, IL 61350

Phone: **815-434-0846**

Circle 33 on Reader Service Card

**BUY QUALITY
FOR LESS!
MAXELL**

5 1/4" DS/DD 49¢

3 1/2" DS/DD 1.05

LIFETIME WARRANTY

Price based on quantity of 300 in bulk includes Tyvek sleeves and label kits.

800-222-0490

In NJ 201-462-7628

FAX 201-462-5658

• 24 Hour Shipment •

MEGA Soft

P.O. Box 710, Freehold, NJ 07728

Circle 170 on Reader Service Card

**9-Track Tape
For Your
IBM PC/XT/AT/PS-2™**

Read 1600 bpi 9-track tapes from a micro, mini or mainframe in EBCDIC or ASCII as mirror image or by individual files.

Use the 2000 PC™ for disk backup, data interchange or archival storage.

PC/XT/AT/PS-2 are trademarks of IBM. 2000 PC is a trademark of Digi-Data.



DIGI-DATA CORPORATION
8580 Dorsey Run Road
Jessup, MD 20794-9990
(301) 498-0200
Telex 87-580

... First In Value

Circle 86 on Reader Service Card

**RELAY
INTERFACE**

AR-16 (16 CHANNEL) **\$89.95**

CONTROLS 16 EXTERNAL RELAYS. EXPANDABLE TO 128 RELAYS. (RELAYS OPTIONAL)
LATCHED RELAYS WITH STATUS AVAILABLE.

ANALOG TO DIGITAL **\$89.95**

ADC-8 (8 CHANNEL) \$99.95
ADC-16 (16 CHANNEL) \$49.95
TE-8 (8 TEMP. SENSORS)

INPUT TEMPERATURE, ENERGY USAGE, ETC. 8 BIT RESOLUTION VOLTAGE INPUT ADJUSTABLE... (0 TO 5 VOLT TYPICAL). EXPANDABLE TO 32 ANALOG INPUTS OR 128 STATUS INPUTS AND UP TO 112 RELAYS.

STATUS INPUT **\$99.95**

STA-8 (8 CHANNEL) \$119.95
STA-16 (16 CHANNEL)

INPUT ON/OFF STATUS OF SWITCHES, RELAYS, THERMOSTATS, SECURITY DEVICES, ETC. OPTIONAL TOUCH TONE INPUT AVAILABLE EXPANDABLE TO 144 STATUS INPUTS OR 16 ANALOG INPUTS AND UP TO 112 RELAYS.

ABOVE HARDWARE IS FOR USE WITH IBM AND COMPATIBLES, TANDY, APPLE, AND MOST OTHER COMPUTERS WITH RS-232 OR RS-422 PORTS USE OUR 800 NUMBER TO ORDER FREE INFO.

24 HOUR ORDER LINE (800) 842-7714
VISA • MASTERCARD • AM EX • COD

ELECTRONIC ENERGY CONTROL, INC.
380 SOUTH FIFTH STREET, SUITE 604
COLUMBUS, OHIO 43215
(614) 464-4470

Circle 93 on Reader Service Card

**GANG PROGRAMMER Does
50,000 EPROMs A WEEK!**



The only programmer under \$1000.00 that withstands heavy duty operation. Easy to use. Fastest possible programming speed. **GANGPRO-8™** is a sure bet when reliability is what you want. All this plus a one year warranty and update for only \$995.00!

**LOGICAL
DEVICES, INC.**

1201 N.W. 65th Place
Ft. Lauderdale, FL 33309
(305) 491-7404
1-800-331-7766

Circle 153 on Reader Service Card
(DEALERS: 154)

**STAND-ALONE UNIVERSAL
PLD PROGRAMMER**
Costs Less, Performs More

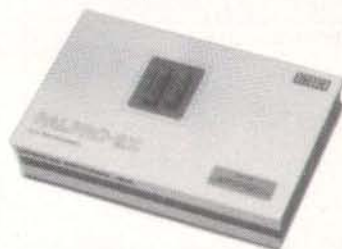

Palpro-2x™ is an intelligent programmer supporting PLDs from a wide variety of sources. Works with any PC or computer using a serial port. FREE one year device update and warranty. Price \$795.00.

**LOGICAL
DEVICES, INC.**

1201 N.W. 65th Place
Ft. Lauderdale, FL 33309
(305) 491-7404
1-800-331-7766

Circle 155 on Reader Service Card
(DEALERS: 156)

DATA ACQUISITION

ALL needs ! ANY computer !

- PC Software Included
- Serial, Modem, & Bus
- Stand Alone Ability
- Laptop & Handheld
- PC & MAC Cards
- Inexpensive
- OEM & VAR
- RTU's

Call for FREE DEMO DISK !

Specialists in portable and battery backed up as well as PC compatible modular systems.



Call for applications info: (201) 299-1615
P.O. Box 246; Morris Plains, NJ 07950

ELEXOR

MEASUREMENT TO GO

Circle 94 on Reader Service Card



SAME DAY SHIPMENT

D - RAMS

41256 - 06 ~ \$9.50	256 x 4 - 10 ~ \$19.00
41256 - 07 ~ \$9.00	64 x 4 - 10 ~ \$9.50
41256 - 08 ~ \$8.50	64 x 4 - 12 ~ \$8.50
41256 - 10 ~ \$7.30	1mg x 1 - 08 ~ \$22.00
41256 - 12 ~ \$6.90	1mg x 1 - 10 ~ \$17.00
41256 - 15 ~ \$6.50	1mg x 1 - 12 ~ \$16.00

MATH CO-PROCESSORS

8087-3 ~ \$88.00	80287 - 10 ~ \$218.00
8087-2 ~ \$120.00	80287 - 12 ~ \$280.00
8087-1 ~ \$170.00	80387 - 16 ~ \$318.00
80287-6 ~ \$130.00	80387 - 20 ~ \$390.00
80287-8 ~ \$195.00	80387 - 25 ~ \$480.00

MODEM 2400 BPS Internal ~ \$69.00
VOICE CARD ~ \$199.00

**CALL FOR QUANTITY PRICES
1-800-2-SABINA**

SABINA INTERNATIONAL, INC.

657 Brea Canyon Road, Suite #4
Walnut, California 91789

(714)594-6336 • FAX (714)595-4008
PRICES SUBJECT TO CHANGE WITHOUT NOTICE

Circle 246 on Reader Service Card

**UNIVERSAL
PROGRAMMER**

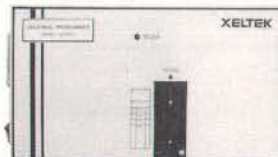

- For E(E)PROM, PAL, BIPOLAR 8748/51Series PROGRAMMING & IC/Memory TESTING
- High-Speed, Parallel Interface

ONLY \$545 COMPLETE
Also Individual/Gang Units

XELTEK

473 Sapena Ct. Unit 24
Santa Clara, CA 95054

1-800-541-1975 (Toll Free Order)
Tel: (408)727-6995, Fax: (408) 727-6996
COD, VISA, MC, AM EX Accepted

Circle 297 on Reader Service Card

COMPARE OUR NEW LOWER PRICES AND SUPERIOR QUALITY

PCI-286-12

- 80286-12
- 1.2 MB Floppy Drive
- 640K RAM
- Serial / Parallel / Game
- 101-Key Enhanced Key Board
- SI = 13.3 (1 Wait)
- SI = 15.2 (0 Wait \$100 Option)
- 6/12 MHz Key Board Switchable
- WA2 HD & FD Controller
- 80287 SOCKET
- 200W POWER SUPPLY

- MONO SYSTEM
- W/Mono Monitor
 - 20 MB Hard Disk

\$1195

- VGA COLOR SYSTEM
- W/VGA Card + Monitor
 - 20 MB Hard Disk

\$1795

- EGA COLOR SYSTEM
- W/EGA Card + Monitor
 - 20 MB Hard Disk
- \$1580**



PCI-386-20

- 80386-20
 - W/40 MB HD
- Mon System **\$2095**
EGA **\$2495**
VGA **\$2795**

GAS PLASMA 286-12 ___ \$1999

- 80286-12 CPU
- SI = 13.3
- 3 1/2" FD 1.44 MB
- 20 MB HD ST-138
- LCD Screen (640 X 400)
- I/O Card Parallel/Serial/Game
- 640K RAM



GAS PLASMA 286-20 \$2295

- CPU 80286-20
- SI = 23

LCD-286-10 PORTABLE ___ \$1395.00

- 10 MHz 80286 SI = 10.3
- 12 MHz SI = 13.3 (Option \$50.00)
- 16 MHz SI = 18 (Option \$250.00)
- 640K RAM
- LCD Screen 640 X 200 (Option 640 X 400 \$180.00)
- Super Twist & Back Lighting
- 86 Key Board
- External / Parallel / Game
- 1.2 MB Floppy drive
- 20 MB Hard Disk
- 80287 Socket
- 200 W Power Supply
- Side 15 3/4" X 9 1/2" X 8"
- 23 LBS



LCD-386-16 ___ \$2495

- 80386-16 MHz
- 40 MB Hard Disk
- 80387 Socket

LCD-386-20 ___ \$2595

- 80386-20 MHz
- 40 MB Hard Disk
- 80387 Socket

CRT-PORTABLE-286 ___ \$1295

- Compaq Type
- 80286 (10 MHz or 12 MHz)
- 12 MHz SI = 13.3 (Option \$50.)
- 16 MHz SI = 18 (Option \$250)
- One 1.2 MB Floppy Drive
- 200 W Power Supply
- TTL Disply 9" Amber
- AT Key Board
- Serial / Parallel / Game
- WA2 HD & FD Controller
- 20 MB Hard Disk



CRT-386-16 \$2289

- 80386-16

CRT-386-20 \$2389

PCI PACIFIC COMPUTER

702 S. Del Mar Ave., #B,
San Gabriel, California 91776
(FAX) 818-286-8662

(818) 571-5548 (Technical support)

(800) 421-1102 (IN CA) ORDER ONLY

(800) 346-7207 (OUT CA)

Mon - Sat
9:00 AM - 6:00 PM



*ALL SYSTEMS COME WITH ONE YEAR PARTS & LABOR WARRANTY



MLC-XT™

SINGLE BOARD PC/XT COMPUTER FOR THE INDUSTRIAL WORLD

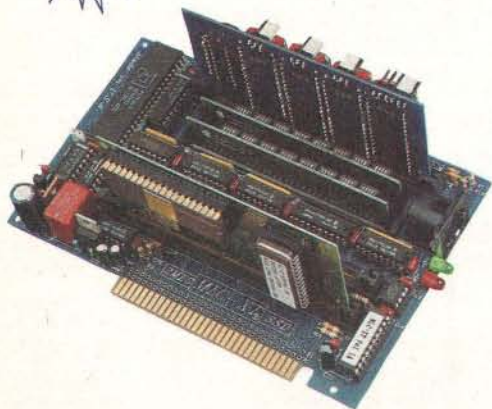

• SOLID STATE DISK (ON BOARD)

Up to 2 MEG memory - Read/Write and Erasable - Supports EPROM, SRAM and new FLASH Memory. Use standard DOS commands to Read/Write.

• WATCHDOG TIMER

Selectable time out - Power monitor.

• 100% PC/XT COMPATIBLE

- Uses INTEL Wildcard* - 8088 Proc.
- 8087 Math Coprocessor socket
- Up to 512K RAM
- 4.77, 7.2Mhz (9.54Mhz optional)
- PC BUS compatible

• WILDCARD PERIPHERAL SOCKET

New embedded system standard

• SMALL SIZE (6.4" x 4.2")

• LOW POWER

Now you can autoboot MS-DOS* and run your application program directly from a reliable solid state disk — standard with the MLC-XT™. This gives you EPROM ruggedness and eliminates the need for a floppy or hard disk in your system. Further reliability is provided by a watchdog timer — a must for dependable industrial and OEM applications.

Call or write for more complete information on the low cost MLC-XT™, supporting peripherals, enclosures, and development systems. Our engineering staff is here to help you with custom software, peripherals, and applications.

MLC-1A™ \$247.00

8052 Controller with on board BASIC and EPROM Programmer

Easy to use single board computer. User can write and execute a program in BASIC, even store it on EPROM within minutes of initial hookup.

Software Features

- Floating point math
- File programs on EPROM
- Auto-execute programs on power-up
- BASIC can call assembly routines
- Interrupt handling in BASIC

Hardware Features

- 8052 based controller
- EPROM programmer
- Real-time clock
- 48 programmable I/O lines
- Two RS-232 ports
- PWM output
- 11Mhz clock

NEW MB-3A - Three slot motherboard \$212.00 with RAM/ROM and I/O expansion. Plug in 2 line x 40 char. LCD display and 4 x 4 keypad with software drivers.

Other peripherals:

- AD8-8 8 Bit - 8 channel A/D board \$170.00
 - DA8-8 8 Bit - 8 channel D/A board \$208.00
 - AD12-8 12 Bit - 8 channel A/D board \$184.20
 - DA12-8 12 Bit - 8 channel D/A board \$296.20
 - FC24-8 24 Bit - 8 channel freq. counter \$294.13
- AC/DC I/O boards, power supplies etc.



Micro Linear Controls, Inc.®

1713 Mount Pleasant St., Racine, WI 53404-1099 (414) 639-1105

Technical Support Hotline: (414) 637-0853 • FAX: (414) 637-0859 • PC-access BBS: (414) 634-5776

All Micro Linear Controls products are trademarks of Micro Linear Controls, Inc. *Signifies trademarks of entities other than Micro Linear Controls, Inc. All prices and specifications are subject to change without notice.

Call:
(414) 639-1105
OEM and Volume
Discounts Available

VOICE MASTER KEY[®] VOICE RECOGNITION SYSTEM FOR PC/COMPATIBLES & TANDY 1000 SERIES A FULL FEATURED VOICE I/O SYSTEM

GIVE A NEW DIMENSION TO PERSONAL COMPUTING. . . The amazing **Voice Master Key System** adds voice recognition to just about any program or application. Voice command up to 256 keyboard macros from within CAD, desktop publishing, word processing, spread sheet, or game programs. Fully TSR and occupies less than 64K. Instant response time and high recognition accuracy. Voice recognition tool-box utilities are included. **A genuine productivity enhancer!**

SPEECH RECORDING SOFTWARE. . . Digitally record your own speech, sound, or music to put into your own software programs. Software provides sampling rate variations, graphics-based editing, and data compression utilities. Create software sound files you can add to macros for voice recognition verification response. **A complete, superior speech and sound development tool.**

SOFTWARE CONVERSION CODES. . . The **Voice Master Key System** operates a growing list of third party talking software titles using synthesized phonetics (text-to-speech) or digitized PCM, ADPCM, and CVSDM encoded sound files. **Voice Master Key System does it all!**



EVERYTHING INCLUDED. . . **Voice Master Key System** consists of a plug-in card, durable lightweight microphone headset, software, and manual. Card fits any available slot. External ports consist of mic inputs and volume controlled output sockets. **High quality throughout, easy and fun to use.**

ONLY \$149.95 COMPLETE

**ONLY \$89.95 FOR TANDY 1000 SL/TL MODELS—
SOFTWARE PACKAGE ONLY.**

Requires Tandy Brand Electret microphone.

ORDER HOTLINE: (503) 342-1271

Monday-Friday, 8AM to 5PM Pacific Time

Visa/MasterCard, company checks, money orders, CODs (with prior approval) accepted. Personal checks subject to 3 week shipping delay. Specify computer type and disk format (3 1/2" or 5 1/4") when ordering. Add \$5 shipping charge for delivery in USA and Canada. Foreign inquiries contact Covox for C & F quotes. **30 DAY MONEY BACK GUARANTEE IF NOT COMPLETELY SATISFIED. ONE YEAR WARRANTY ON HARDWARE.**

CALL OR WRITE FOR FREE PRODUCT CATALOG



COVOX INC. 675-D Conger St.
Eugene, Oregon 97402 U.S.A.
TEL: 503-342-1271 • FAX: 503-342-1283

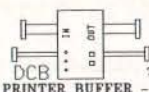

! not only a
printer buffer !

THIS IS THE MOST SOPHISTICATED
PRINTER BUFFER - MULTIPLEXOR - SWITCH

WITH TWO SEPARATE INPUTS (SERIAL AND PARALLEL) AND TWO SEPARATE OUTPUTS (SERIAL AND PARALLEL) - CAN BE USED LIKE STANDARD BUFFER WITH ANY INPUT TO ANY OUTPUT - BUT ALSO YOU CAN CONNECT 2 COMPUTERS TO 1 PRINTER, OR 1 COMPUTER TO 2 PRINTERS, OR 2 COMPUTERS AND 2 PRINTERS AND MORE - 1 COMPUTER TO 3 PRINTERS OR 5 COMPUTERS TO 1 PRINTER
HIGH CAPACITY - 64 KB TO 256 KB AND - 256 KB TO 1 MB (MODELS A AND B) PAUSE, COPY AND RESET FUNCTIONS. SERIAL PORTS WITH 7 OR 8 BITS WORD LENGTH, 1 OR 2 STOP BIT, PARITY, XON/XOFF, DTR, RTS

DOB-A-64K \$ 195 DOB-B-256K \$ 255 (*)

(*) Power supply and parallel cables are included

ALSO, WE HAVE THE MOST COMPLETE DATA CONVERTER UNIT CONVERTS RS232 SERIAL TO CENTRONICS PARALLEL OR VICE VERSA, JUST BY MOVING JUMPER BAUD RATE AND PROTOCOL FULLY PROGRAMABLE FROM 160 TO 19200 BAUDS INCLUDES: DTR, RTS, XON/XOFF, PARITY, etc

DCU \$ 80 (**)

(**) Power supply and cables NOT included



serial \leftrightarrow parallel
bi-directional converter



INTECTRA Inc. - Dept. 232

2029 TERMINAL BLVD
MOUNTAIN VIEW - CA - 94043

(415) 967-8818 TX 345545



System 1800
Basic System \$899
(MADE IN U.S.A.
with quality)

- Intel 80286 CPU
- Fully compatible with IBM AT
- 6MHz selectable, 8 slots
- 512K on 1M mother board
- 95 watt power supply 100/220
- Clock/Calendar, Everset
- HD/FD cont.
- FCC class "B" approved
- 48 Hour factory high temp. dynamic burn-in
- 1.5 MEG. Base Dr. AT Keyboard
- Flame Arrester, Lotus, Xenix, Novell, all prop. Software
- 200 pages of documentation (written in U.S.A.)
- 80287 CO-Processor socket
- 80300 units installed with customer report on file
- Made in U.S.A.
- with 1 year warranty

mono Sys. (Basic Sys. + Evergraphics 132 col. w/po., 14" Everset Flat Mon.)	Special: \$995
USA Sys. (Basic Sys. + Everset EGA card + 14" Everset EGA (300mm) Mon.)	\$1414
Super EGA Sys. (Basic Sys. + Everset EGA card + NEC Intranor 1800 (300mm) Mon.)	\$1700
System 1800 10MHz: 286 0 wait, 512K, 25.6K. Base system	\$1099
System 1700 10MHz: 286 0 wait, 1 meg. RAM, KB. Base system	\$1295
System 3000 10MHz: 386 0 wait, 1 meg. KB. Base system	\$1795
System 3000 20MHz: 386 0 wait, 1 meg. KB. Base system	\$2200

Full Line of Everset Products Available			
NEW			
• 640K	385-200, 1m	\$2295	
• 1.2m Dr.	385-400, 1m	\$2795	
PORTABLE	• 640 x 200	286-500, 512K	\$1629
• Super Telet LCD	286-1200	\$1395	
• Back Lite			

Schwab Computer Center
"The Everset Store" - Authorized Everset Corp. WAR
3082 El Camino Real, Santa Clara, CA 95051
408-241-1210 Fax # 408-241-1279
Daily UPS M-F 9-7, SAT 11-4 VISAC/MC/IE
Prices change without notice

Circle 251 on Reader Service Card

A REAL BREAKTHROUGH—NO BULL!

**20 MB HARD DRIVE
\$89**

Turn your 10 MB Hard Drive into a real 20 MB Hard Drive!
Our easy to use software is not a file compression program and it's not memory resident!
Use it once. It actually changes the physical characteristics of your 10 MB Hard Drive and makes it a permanent 20 MB Hard Drive.
No new hardware required.
It's true—Money Back Guarantee!
We pay S & H. Mail \$89 to:

SWIRLSOFT

3240 Dueber Avenue S.W.

Canton, Ohio 44706

216-484-5320

Or order COD. You pay COD fee.

DATA CONVERSION SYSTEMS

**9-Track Tape for your PC, AT,
PS/2, MAC, Sun**

Read/write data from nearly any Mainframe: IBM, DEC, HP, DG, or Honeywell. Runs under MS-DOS, Unix, Xenix, MAC, and SunOS.

8" 5 1/4" 3 1/2"

**Diskette converter
for your PC/XT/AT**

Our diskette conversion system can read/write and format diskettes from IBM Systems 34, 36, 38, AS400, DEC, CMX, CP/M, Displaywriter and many more.



1-800-223-3693

In California call:
1-415-324-9114

525 Alma, Palo Alto, CA 94301

Circle 181 on Reader Service Card

Advertise your
computer products
through
BYTE BITS
(2" x 3" ads)

For more information
call Mark Stone at
603-924-6830

BYTE

One Phoenix Mill Lane
Peterborough, NH 03458

Circle 320 on Reader Service Card

8051 FAMILY EMULATORS

See EEM
'88/'89



For info call:

Australia	(02) 654 1873
Austria	(0222) 38 76 38
Benelux	+31 1856-16133
Denmark	(02) 65 81 11
Finland	90-452 1255
France	(01) 69 412 801
Great Britain	0962-73 3140
Israel	(03) 484832
Italy	(011) 7710010
Korea	(02) 784 7841
New Zealand	(09) 392464
Portugal	(01) 83 56 70
Scandinavia	+46 40922425
Singapore	065 743-2086
Spain	(93) 217 2340
Switzerland	(01) 740 41 05
Taiwan	(02) 7640215
West Germany	08131-1687
U.S.A. FAX	(408) 378-7869

**NOHAU
CORPORATION**

51 E. Campbell Ave.,
Campbell, CA 95008
(408) 866-1820

Circle 199 on Reader Service Card

Compu\$ave



1-800-877-8855

Government P.O.'s are Welcome!

BOARDS

ADC/Alloy Slaves ... Save Orchid Pro Design + 385
 AST Rampage+ 286 .399 Paradise VGA+ 258
 ATI VGA Wonder ... Save Paradise VGA + 16 .292
 Genoa 5300/5400 ... Save Quad JT Fax 9600 .539
 Intel Aboveboard+ ... 392 Sigma VGA H 275
 Intel Inboard 386 AT ... 826 STB VGA EM 512K 358
 Intel Inboard 386 PC ... 615 Video 7 V RAM 458
 Methus 1104 1025 Video 7 Vega VGA ... 258
 Adaptek, Artist, Hercules, Imagraph, Konan Call
 Number 9, Photon, Pixelworks, Rasterops Call
 Sota, Tops, Verticon, VMI, Western Digital Call

DISK DRIVES

Archive 40Mb Tape ... 319 Miniscribe 676 Mb ... 2825
 Maxtor 1140 1495 Panasonic Worm 1849
 Micropolis 71 Mb 575 Seagate 30Mb Kit 275
 Miniscribe 157 Mb ... 1159 Seagate ST251-1 398
 Miniscribe 3053 429 Teac 1.44 Mb, 3.5" 92
 Miniscribe 338 Mb ... 1929 Toshiba 720 K, 3.5" 75
 CDC, Core, Emerald, Genoa, Iomega, Irwin Call
 Maynard, Plus, Priam, Moutain, Storage Dimen. Call

SOFTWARE

Autosketch 2.0 64 Microsoft Word 5.0 212
 Bitstream Fonts 105 PC Excel/Windows 235
 Carbon Copy Plus ... 107 Peachtree Dbl Bonus 219
 DBase IV Save Peachtree Complete ... 146
 Fastback Plus 104 Quattro 157
 Harvard Graph 279 Rightwriter 3.0 52
 Lotus 123 319 Ventura Publisher 489
 Lotus Symphony V2 415 XTree Pro 68
 Microsoft PCWorks ... 95 WordPerfect 5.0 225

Mail Address: Compu\$ave - 4207 S. 37th Street - Dept B6 - Phoenix, AZ 85040. Order lines open: Mon.- Fri. 7 am - 6 pm, Sat.: 9 am - 2 pm. Prices reflect cash discounts and are subject to change without notice. We do not guarantee compatibility. DOA's are repaired or replaced, please call for a RMA. Major credit cards and selected PO's are accepted.

INTERNATIONAL SALES (602)437-4855

FAX (602)437-9685

CUSTOMER SERVICE (602)437-4856

COMPUTERS

Acer Computers Save Televideo 286/386. Save
 Altos Computers Save Toshiba 1000 778
 AST Computers Save Toshiba T1200F 1359
 AT&T Computers Save Toshiba T1200FB ... 1545
 Cordata Computers Call Toshiba T1200HB ... 2345
 Everex Step 286/386. Save Toshiba T1600 3199
 Mitsubishi 20 Mb Lap ... 2298 Toshiba T3100E ... 2745
 Mitsubishi 40 Mb Lap. Save Toshiba 3200 3465
 Mitsubishi 286/386 Save Toshiba 5100 4575
 NCR Computers Save Toshiba 5200 6199
 NEC Computers Save Wyse 2108 929
 Packard Bell Systems Save Wyse 2112 1375
 Panasonic 286/386 Save Wyse 3216 2099
 Samsung 286/12 1199 Zenith Supersport ... Save

CHIPS

Intel 80287 6/8/10 Mhz 139/204/238
 Intel 80387 16/20/25 Mhz 359/415/499

TERMINALS

Altos V 485 Televideo 965 395
 IBM 3151 385 Wyse 30 285
 Kimtron KT-70 PC 339 Wyse 50 355
 Link MC-S 392 Wyse 60 392
 Televideo 905 299 Wyse 99 GT 455
 Televideo 955 379 Wyse 150 369
 Adds, Ampex, HP, Sun River, & Other Models Call

MICE

Logitech C7 Serial 62 Microsoft w/ paint 99
 Logitech New HiRes 86 Microsoft w/windows ... 132
 Keytronic Pro 79 Mouse Systems PC II ... 89

PLOTTERS

Calcomp 1023GT 3712 HP 7595 A 6795
 Calcomp 1025E Save HP Draftpro DXL ... 3699
 Calcomp 1044GT ... 10,235 HP Draftpro EXL ... 4699
 Enter SP1000 2329 Ioline 3500 2375
 Houston DMP 52 2295 Ioline 3700 2995
 Houston DMP 61 2995 Ioline 4000 3695
 Houston DMP 62 4095 JDL 850 GL 2799
 HP 7475 A 1395 Roland 885 675
 HP 7550 A 2895 Roland 980 869
 HP 7570A 2875 Roland DXY 1100 889
 Bruning, Numonics, Mural, Versatec Call

DIGITIZERS

Calcomp12 x12 342 Kurta IS 12 x 12 282
 Calcomp 44 x 60 3895 Kurta IS 12 x 17 482
 GTCO 24 x36 1895 Numonics Save
 GTCO 36 x 48 2345 Scriptel Save
 Hitachi 11 x 11 439 Seiko Save
 Hitachi Puma Pros Save Summa 12 x 12 + 338
 Houston Hi Pad + Save Summa 12 x 18 568

MODEMS

ATI 2400 ETC, Int. 15" Practical 1200 Ext. 76
 Anchor 2400E 145 Practical 1200I 65
 Cardinal 2400 Int. 109 Prometheus 2400B/2 .129
 Hayes 1200 Ext. 275 Prometheus 2400G ... 149
 Hayes 2400 Ext. 415 Racal-Vadic 2400VP ... 388
 Multitech 224 EH Save USR HST 9600 599
 Multitech 9600 Save World Port Pocket Save
 Multitech v.32 9600 Save Zoom 2400 Ext. 122
 Okidata 2400 ext 209 Zoom 2400 HC 119
 Avatex, Penril, Pack. Bell, Telebit, Ventel, UDS Call

PRINTERS

Alps Allegro 24 318 Panasonic 1124 Save
 Brother HLBE 2045 Panasonic Laser 1425
 Canon BJ 130 725 Okidata ML 320 329
 Citizen MSP45 375 Okidata ML 390 455
 Citizen 1800 162 Okidata ML 391 632
 Diconix D150 294 Okidata ML 321 455
 NEC LC 890 3189 QMS Kiss Plus 1665
 NEC P2200 345 QMS PS810 3999
 NEC P5200 498 Qume Crystal Print ... Save
 NEC P5300 654 Qume Script Ten ... 3199
 Panasonic 1180 189 Star NX-1000 172
 Panasonic 1191 249 Star NX-2400 299
 Fujitsu DL3400: 24pin, 132 col. 240cps 508
 Brother, C.Itoh, Data Products, Epson, HP, Genicom
 OTC, Seikosha, TI, Vantyper, Toshiba Call

MONITORS

Amdek 1280 638 NEC Multisync 3D ... 665
 Amdek 732 399 NEC Multisync 2A ... 499
 Conrac/Relisys Save PGS Ultra 16 869
 Cornerstone Save Packard Bell TTL 75
 Genius 402/420 Save Seiko 14" 1024x768 .578
 Hitachi 20" Multi 2095 Sigma Laser + 19" 1695
 Mitsubishi 1381A 475 Sony 1302 639
 Mitsubishi HL6605 .1199 Samsung 14" RGB ... 209
 Moniterm Save Samsung Multi 425
 Nanao Flexscan 995 Zenith 1490 589

SCANNERS

DFI Handy Scanner ... 219 PC Hand Scanner ... 157
 PGS LS-300 w/paint .725 Logitech Scan Man ... 215
 AST, Datacopy, Dest, HP, Panasonic, Taxan Call

BYTE BACK ISSUES FOR SALE

1986 1987 1988 1989

	1986	1987	1988	1989
January				
February				
March				
April				
May				
June				
July				
August				
September				
October				
November				
December				
Inside the IBM PCs Applications Software Today				

Issues Available

Rates (postage and handling included):

1985 BYTE Issues	\$4.00	BYTE 1987 Index	\$3.00
1986-'89 BYTE Issues	\$6.00*	1985 Inside The IBM PCs	\$4.00
BYTE '83-'84 Index	\$3.00	1986 Inside The IBM PCs	\$5.00
BYTE 1985 Index	\$3.00	1988 Inside The IBM PCs	\$6.00
BYTE 1986 Index	\$3.00	Applications Software	
*June 1988 (Benchmarks) \$3.00		Today Special	\$4.00

The above prices include postage in the US. Please add \$.50 per copy for Canada and Mexico; and \$2.00 per copy to foreign countries (surface delivery). European customers please refer to Back Issue order form in International Advertising section of book.

Please indicate which issues you would like by checking (✓) the boxes. Send requests with payment to:

BYTE Back Issues, One Phoenix Mill Lane, Peterborough, NH 03458
 (603) 924-9281

Check enclosed Charge: VISA MasterCard

Card # _____

Exp. Date _____

Signature _____

Name _____

Address _____

City _____

State _____ Zip _____

All orders must be prepaid. Please allow four weeks for domestic delivery and twelve weeks for foreign delivery by surface mail.

CAT™ 10MHZ BASE SYSTEM

- 256K (Opt. 640K) • 150 Watt Power Supply • AT Style Keyboard & Case
- 4.77 or 8 MHz Keyboard Selectable • FDC
- 8087 Socket • 360K Floppy Drive • 1 Year Warranty

\$36900

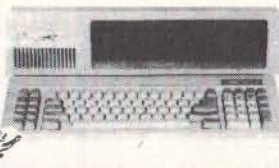

CAT 386 SYSTEM

- 12" Amber Monitor with Graphics Interface Card
- 1.2 Meg Floppy Drive (expandable to 8 Meg)
- 1 Meg of Memory
- Parallel, Serial & Clock
- 70 Meg Hard Drive

20MHz

\$229700

CAT™ 286-10MHZ BASE SYSTEM

- 512K Exp. to 1 MEG • 200 Watt Power Supply • AT Style Keyboard
- Western Digital Controller • 1.2 Meg Floppy • Legal Bios w/manuals • Systems Documentation • 1 yr war. • Clock/Calc
- 10MHz DTK Motherboard

\$74900

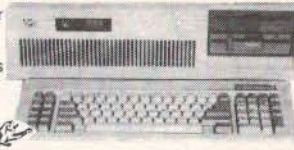

11.3 NORTONS SL

8088 XT Compatible

640 K Upgrade	139 ⁰⁰	Clock Calendar	24 ⁰⁰
12" Amber Monitor w/Interface	139 ⁰⁰	Parallel & Serial Ports	39 ⁰⁰
DOS 4.01 w/GW BASIC	89 ⁰⁰	Additional Drives	See Below

SYSTEM OPTIONS

286, 386 AT Compatible

640 K Upgrade	49 ⁰⁰	14" EGA Monitor w/Interface	549 ⁰⁰
1 Meg Upgrade	159 ⁰⁰	Novell Network. Call 12 Mhz add	109 ⁰⁰
12" Amber Monitor w/Interface	139 ⁰⁰	14" Color Monitor w/Interface	289 ⁰⁰

WE WILL NOT BE UNDERSOLD

SEAGATE EVEREX INTEL WESTERN DIGITAL SAMSUNG ALL RAM UPGRADES

WE WILL BEAT ALL COMPETITORS QUOTES CALL (800) 654-7762

intel COPROCESSORS

If Your PC Uses the Intel	Running at . . .	Then You Need Intel	MEADS PRICE
8088	5MHz or less	8087	97 ⁰⁰
8088 or 8086	8MHz or less	8087-2	139 ⁰⁰
8086	10MHz or less	8087-1	199 ⁰⁰
80286	6-8MHz	80287	149 ⁰⁰
80286	8-10MHz	80287-8	229 ⁰⁰
80286	10MHz or more	80287-10	259 ⁰⁰
80386	16MHz	80387-16	379 ⁰⁰
80386	20MHz	80387-20	439 ⁰⁰
80386	25MHz	80387-25	559 ⁰⁰
386SX	16MHz	80387-SX	399 ⁰⁰

RAM UPGRADES

WE BUY EXCESS RAMS PLEASE CALL OR FAX LIST

64K	1 Meg.
4464 100 NS, 64x4 . . . 119 ⁰⁰	1Meg x 1 120 NS . . . 17 ⁰⁰
4464 120 NS, 64x4 . . . 109 ⁰⁰	1Meg x 1 100 NS . . . 19 ⁰⁰
4464 150 NS, 64x4 . . . 99 ⁰⁰	1Meg x 1 80 NS . . . 24 ⁰⁰
4164 150 NS, 64x1 . . . 29 ⁰⁰	
4164 120 NS, 64x1 . . . 32 ⁰⁰	
4164 100 NS, 64x1 . . . 34 ⁰⁰	
	Simm Modules
	64 x 9 150 NS . . . 29 ⁰⁰
	256 x 8 120 NS . . . 49 ⁰⁰
	256 x 9 80 NS . . . 99 ⁰⁰
	256 x 9 100 NS . . . 89 ⁰⁰
	256 x 9 120 NS . . . 79 ⁰⁰
	1Meg x 9 120 NS . . . 219 ⁰⁰
	1Meg x 9 100 NS . . . 239 ⁰⁰
	1Meg x 9 80 NS . . . 299 ⁰⁰
	1Meg x 8 120 NS . . . 149 ⁰⁰

MISCELLANEOUS
2nd Serial Upgrade . . . 19⁰⁰
2764-25 . . . 3⁰⁰
4128 . . . 3⁰⁰

EVEREX™ TAPE BACKUPS

40MB Mini Cartridge, 1.8MB/min, XT	339 ⁰⁰
40MB Mini Cartridge, 3.6MB/min, AT	339 ⁰⁰
40MB Streaming Cassette, 5MB/min w/cont.	589 ⁰⁰
60MB Streaming Cassette, 5MB/min w/cont.	649 ⁰⁰
60MB Streaming 600A, 5MB/min w/Full cont.	849 ⁰⁰
125MB Streaming Cartridge, 5MB/min w/Full cont.	1119 ⁰⁰
Excell 60 Model 60/80	999 ⁰⁰
Excell 125 Model 60/80	1269 ⁰⁰

External Add 195⁰⁰

HARD DRIVES

ST125 20Meg 40 Mil 1/2 Ht 3 1/2" Drive only	279 ⁰⁰
ST138 30Meg 40 Mil 1/2 Ht 3 1/2" Drive only	339 ⁰⁰
ST225 20Meg w/cont. & Cables	269 ⁰⁰
ST238 30Meg w/cont. & Cables	299 ⁰⁰
ST251 40Meg 1/2 HT 40 Mil w/software, Drive only	379 ⁰⁰
ST251-1 40Meg, 28 Mil Sec, Drive only	439 ⁰⁰
ST277R 60MB 40 Mil 1/2 Ht	489 ⁰⁰
ST4026 20Meg Full Ht 40 Mil	299 ⁰⁰
ST4038 30Meg 40 Mil Full Ht	399 ⁰⁰
ST4053 40MB 28 Mil Full Ht	519 ⁰⁰
ST4096 80Meg Full Ht w/software	649 ⁰⁰

WESTERN DIGITAL CONTROLLERS

WX-1 8 Bit 1/2 Sized for XT	79 ⁰⁰
WA-2 16 Bit Full Sized Hard/Floppy	119 ⁰⁰
WD-27X 8 Bit RLL 1/2 Size	89 ⁰⁰
WAH 16 Bit Hard Drive Controller	129 ⁰⁰
RA2 16 Bit RLL Hard/Floppy for AT	159 ⁰⁰
MEAD Floppy Disk Controller for XT, controls 4 drives	29 ⁰⁰
MEAD 1.2 Meg & 360K Controller for XT	69 ⁰⁰
Cable Set for Hard Drive Only	5 ⁰⁰

FLOPPY DRIVES

360K 1/2 Ht. PC Compatible — Mitsumi	69 ⁰⁰
1.2 Meg Black Face — Mitsumi	89 ⁰⁰
720K 3 1/2" Drive w/5 1/4" mounting — Mitsumi	89 ⁰⁰
1.44 Meg 3 1/2" Drive w/5 1/4" mounting — Mitsumi	109 ⁰⁰
360K Tandon TM100-2 Full Ht.	89 ⁰⁰
160K Tandon TM100-1 Full Ht	49 ⁰⁰
External Case w/Power Supply	149 ⁰⁰

MODEMS BY EVEREX™

EV-923 EverCom 12 300/1200 bps Bitcom Software	69 ⁰⁰
EV-941 EverCom 24 2400 Baud Int. Bitcom Software	139 ⁰⁰
EV-945 External 2400 Baud	199 ⁰⁰

For error correcting add \$10.00

COMPUTER PERIPHERALS — 5 YEAR WARRANTY

1200 Baud Internal w/Software	54 ⁰⁰
1200 Baud External fully Hayes Compatible, Everex	99 ⁰⁰
2400 Baud Internal 1/2 card w/software	99 ⁰⁰
2400 Baud External Fully Hayes Compatible, Zoom	129 ⁰⁰

Intec/SAMSUNG MONITORS

1256A 12" Amber w/Tilt & Swivel Base	79 ⁰⁰
1257 12" Amber Flat Screen 720 x 350	99 ⁰⁰
1464 14" Color 640 x 200, 16 colors	239 ⁰⁰
1453 14" EGA 640 x 350, 64 colors/31	369 ⁰⁰
1455N EGA 720x480 Multisync Compatible	439 ⁰⁰

★ SPECIALS ★ SPECIALS ★ SPECIALS ★ SPECIALS ★ SPECIALS ★

GOOD THRU 6-31-89

VIDEO RAM & BOARDS

Video Ram for VGA Cards 120NS, 64x4	
64x4, 120NS Zippis	14 ⁰⁰

VIDEO 7 — 5 Year Warranty

Vega VGA . . . 329 ⁰⁰	V-Ram VGA . . . 649 ⁰⁰	Fastwrite VGA . . . 439 ⁰⁰
----------------------------------	-----------------------------------	---------------------------------------

EVEREX TAPE BACKUP

40Meg for XT, Mini Cartridge 870A	279 ⁰⁰
-----------------------------------	-------------------

COMPUTER PERIPHERALS MODEM

2400 Baud Internal, Hayes Compat, auto answer, auto dial, 5 Year Warranty PC-XT-AT Compatible	98 ⁰⁰
---	------------------

EVEREX MEMORY BOARDS

Base / Extended / Expanded 4.0 IBM Compatible	
286 AT 0-3 Meg . . . 149 ⁰⁰	286 AT 0-10 Meg . . . 199 ⁰⁰
Expanded / Extended EMS 4.0 com. uses 1 Meg 120NS chips	
PS2 50/60 0-2 Meg . . . 259 ⁰⁰	PS2 50/60 0-4 Meg . . . 299 ⁰⁰

Liquidation Below Dealer Cost — New With Warranties

LETTER QUALITY PRINTER

DAISYWHEEL PRINTER MANUFACTURED BY C.ITOH

Why pay \$1149 for a C.Itoh
STARWRITER™ F-10

When our 40 cps letter quality daisywheel printer from the same manufacturer is only

\$39900
ea.

REPEAT OF A SELLOUT



100 FOR \$34900

OPTIONS

• 6 ft. Serial Cable	\$ 19 ⁰⁰
• Bidirectional Tractor	149 ⁰⁰
• Cut Sheet Feeder	199 ⁰⁰
• Serial to Parallel Converter	99 ⁰⁰

STANDARD FEATURES

- 40 CPS • Accepts Paper to 15 inches • Form Length and Pitch Set from Control Panel
- Industry compatible ribbon, printwheels and control commands • RS232 Serial Interface

MICROSOFT MOUSE



- In Port with Bus Interface
- Fully IBM Compatible (of course)
- Includes Showpartners and Paint Brush

List \$199 Mead **\$7900** 10 for \$740

MEAD MONITOR



- FREE TILT SWIVEL BASE
- 14" Flat Screen • Paper White Phosphorus
- TTL Monochrome & RGB Composite Interface

List \$199 Mead **\$10900** 10 for \$950

STATIC BUSTER

Attached to CRT face and keyboard, Static Buster works just like a sponge, dissipating static at a rated 20,000 volts in less than two seconds.



List 49⁰⁰ Mead 19⁰⁰ 10 for \$160

AT STYLE / XT CASE



- 2 Bay Standard AT Style Case
- Keylock Power and Hard Drive LED's

List 99⁰⁰ Mead 29⁰⁰ 10 for \$240

TEAC

360K Floppy Drive



- 360K Grey Faceplate • 1/2 HT / 558V

List 199⁰⁰ Mead 74⁰⁰ 10 for \$690

CLOSEOUTS QTY. LIMITED

CS 500 Cassettes	14 ⁰⁰
Epson Universal Printer Stand	9 ⁰⁰
Irwin Tape Backup	20Meg 199 ⁰⁰
	XT 40Meg 299 ⁰⁰
10Meg w/controller & cables	179 ⁰⁰
Real IBM AT Vertical Enclosure	49 ⁰⁰

800-654-7762

SALES: 7 a.m.-6 p.m. PST

702-294-0204

CUSTOMER SERVICE / ORDER STATUS:

9 a.m.-4 p.m. PST

FAX 702-294-1168

WE ALSO PURCHASE EXCESS INVENTORY—FAX LIST



- Quantity Pricing Available — CALL
- We Accept International Orders
- Purchase Orders from Universities, Government Institutions, Fortune 1000 and Qualified Firms

*Best Quote applies to competitors advertised price with same terms

NO SURCHARGE FOR MC/VISA

TERMS:

MC • VISA • COD • CASH

Purchase Orders from Qualified Firms

Personal Checks • AE add 4%

20% Restocking Fee on Non-Defective Returns within 15 days



SHIPPING: (min. 6⁰⁰) UPS

**Data Acquisition Interfaces
for IBM PC/XT/AT & PS/2**

**NEW
1989**



**FREE
CATALOG**

- PC Based Instruments
- Motion Control
- Frame Grabber Boards
- Industrial Data Acquisition
- Communications Interfaces
- Software Packages



440 Myles Standish Blvd., Taunton, MA 02780
(508) 880-3000 TLX: 503989 FAX: (508) 880-0179

Circle 173 on Reader Service Card

ICs PROMPT DELIVERY!!!
SAME DAY SHIPPING (USUALLY)
QUANTITY ONE PRICES SHOWN for APRIL 30, 1989

OUTSIDE OKLAHOMA: NO SALES TAX

DYNAMIC RAM			
SIMM (1)	256Kx36	80 ns	\$450.00
SIMM	1Mx9	80 ns	250.00
SIMM (2)	1Mx9	85 ns	210.00
SIMM	256Kx9	80 ns	99.00
1Mbit	1Mx1	100 ns	17.95
41256	256Kx1	60 ns	9.95
41256	256Kx1	80 ns	7.95
41256	256Kx1	100 ns	7.75
51258 (3)	256Kx1	100 ns	7.95
41256	256Kx1	120 ns	7.50
41264 (4)	64Kx4	120 ns	8.50
EPROM			
27C1000	128Kx8	200 ns	\$28.50
27C512	64Kx8	200 ns	12.95
27256	32Kx8	150 ns	8.25
27128	16Kx8	250 ns	4.75
STATIC RAM			
62256P-10	32Kx8	100 ns	\$26.50
6264P-12	8Kx8	120 ns	8.50
6116AP-12	2Kx8	120 ns	5.50

OPEN 6 1/2 DAYS, 7:30 AM-10 PM. SHIP VIA FED-EX ON SAT.

SAT DELIVERY INCLUDED ON FED-EX ORDERS RECEIVED BY: Tu: 8:00 AM - 5:30 PM; Fri: 11:25 AM - 11:00 AM. MasterCard/VISA or UPS CASH COD. MICROPROCESSORS UNLIMITED, INC. 24,000 S. Peoria Ave., GEGGS, OK 74421. (918) 267-4961. No minimum order. Please note: prices subject to change! Shipping, insurance extra, up to \$1 for packing materials.

Circle 180 on Reader Service Card

**Z80
HD64180
MICROPROCESSORS**

**C Compiler
Assembler/Linker
Remote Debug
Realtime Kernel
Emulator
PC Coprocessors
Proto Board**

**Integrated Software/Hardware
Targeted for Z80/64180 Develop-
ment on PC/XT/AT Platforms:**

- C-compiler (UNIX & ANSI std.) \$695.00
- Assembler/linker \$195.00
- In-circuit Emulator \$995.00
- Source/symbolic debugger \$195.00
- Multitasking kernel \$395.00
- Standalone Proto Board (64180μP) \$295.00
- PC Coprocessors—many versions, please inquire

Z-World Engineering

1340 Covell Blvd, Suite 101
Davis, CA 95616

(916) 753-3722

Fax: (916) 753-5141



"Z80 Specialists"

In Germany: 08131/1687

Circle 299 on Reader Service Card

**6800/6809
Micro Modules**

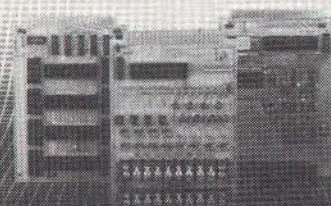

OEM 6800/6809 MICROCOMPUTER MODULES for dedicated control and monitoring. Interfaces for sensors, transducers, analog signals, solenoids, relays, lamps, pumps, motors, keyboards, displays, IEEE-488, serial I/O, floppy disks.



Wintek Corp.
1801 South Street
Lafayette, IN 47904
317-742-8428

Circle 295 on Reader Service Card

**INTELLIGENT
RS-232/422/485**

- *COMMUNICATIONS
- *CONTROL
- *SYSTEMS DEVELOPMENT

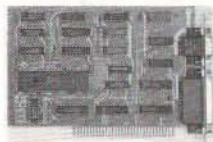

- *Hitachi HD64180 μP (6 or 9 mhz)
- *SBX connectors, 256K-516K RAM
- *2 Serial Ports & 2 DMA channels

Z-World Engineering

1340 Covell Blvd., Ste. 101
Davis, CA 95616

(916) 753-3722

Germany: 08131/1687

Circle 300 on Reader Service Card

New

100% Autorouter

HiWIRE-Plus provides the integrated schematic-capture and PCB layout versatility needed by leading-edge designers. Now it also offers an advanced 100% autorouter. Affordably! See the full-page ad (on page 7) then call Wintek at:

(800) 742-8428

Circle 296 on Reader Service Card

**FREE
Flip'n' File**

"CALL FOR DETAILS"



OFFER ENDS 6-30-89 or WHILE SUPPLY LASTS

NEW! **12⁹⁹**
3M formatted 3.5", DS

NEW! **29⁹⁵**
3M formatted 3.5", DS, HD

NEW! **6³⁰**
3M formatted 5-1/4" DS, DD

NEW! **11⁵⁰**
3M formatted 5-1/4" DS, HD

The Diskette Connection™

- Delaware 1-800-451-1849 P.O. BOX 10247, WILMINGTON, DE. 19850
- Oklahoma 1-800-654-4058 P.O. BOX 1674, BETHANY, OK. 73008
- Nevada 1-800-621-6221 P.O. BOX 12396, LAS VEGAS, NV. 89112

Minimum order \$2000. *No Surcharge on Visa Master Card.* COD orders add \$300. Surface. Shipping UPS add \$400 per 100 for 3 1/2" or 5 1/4", add \$400 per 100 for 8". U.S. Mail delivery add 9%. *Prices subject to change without Notice.*

FAX (405) 495-4598

3M

***FREE! FLIP'N'FILE**
***FORMATTED DISKS AT UNFORMATTED PRICES!!**

DS-DD	Quantity Discounts Available min. 5 boxes	DS-HD
.63*	5.25" 3M Diskettes 10/Box	*1.15
1.29*	3.50" 3M Diskettes 10/Box	*2.95
1.89	SS/DD-8.00" 3M Diskettes-DS/DD	2.15

DC-2000	14.99	DC-600A	20.99
DC-300XLP	18.99	DC-600XTD	21.99

3M Mag. Tapes Std. W/Seal 2400' **12.50**
 3M Compac Tape™ 1/2" DEC TK 50 Tape **26.50**
 IBM 3480 Tape Cartridge **5.85**

BASF

***FREE Extra Quality Library Cases!!**

DS-DD	Quantity Discounts Available	DS-HD
.56*	5.25" BASF Diskettes 10/Box	.84
1.19*	3.50" BASF Diskettes 10/Box	*2.89

.33 BASF No Logo Bulk
 with Tyvek sleeves, labels, & W/P

.29 5.25" BASF SS/DD/48TPI Diskettes
 In BASF Plastic Library Box

maxell

***FREE Plastic Library Box**

MD2-DMP	MD-2HDM	MF-2DDMP	MF2-HD
.63*	1.15	1.32*	3.20

Verbatim

***FREE DataLife Plus with DISCUS 11th Disk!**

5.25" DS/DD	5.25" DS/HD	3-50" DS/DD	3.50" DS/HD
.63*	1.19	1.35	3.20

FUJI

***Free! 11th Disk**
***Free! Plastic Box**

MD-2D	MD-2HD	MF-2DD	MF2-HD
.63*	1.15	1.35	2.99

COLOR DISKETTES

5.25" DS/DD	5.25" DS/HD	3.50" DS/DD
.39	.69	1.09

All 5.25" color diskettes in Tyvek sleeves, labels & w/p

BULK DISKETTES

5.25" DS/DD	5.25" DS/HD	3.50" DS/DD	3.50" DS/HD
.29	.59	.99	2.69

All 5.25" bulk diskettes in sleeves, labels & w/p

INCREIBLE VALUE!!

.39	MD2D	3M Highland	MD2HD	.79
1.09	MF2DD	Nashua	MD2HD	.82
1.29	MF2DD	Sony KAO	MF2HD	2.75

TERMS: No surcharge on VISA, Mastercard or AMEX. COD add \$3.00. Prepaid orders deduct 2% cash discount. PO's accepted from recognized institutions and corporations on Net 30. Bank draft, T/T or L/C acceptable. **Shipping:** \$4/100 or fewer disks. Reduced shipping charges on larger quantities. Price quoted for case (100 disks) quantities less than a case add 5%. (Min order \$20.00)

WE BEAT ANY PRICE!
 Toll Free Order Line: **1-800-523-9681** Information Line: **1-801-255-0080**
 TLX-9102404712 FAX-801-572-3327

DISKOTECH

DISKCO TECHNOLOGIES, INC.
 213 Cottage Avenue
 P.O. Box 1339 Sandy, Utah 84091

SEAGATE		ADD-ON CARDS	
ST-225 with c/c	\$245	Color Graphic	\$ 37
ST-238 with c/c	\$265	Monographic	\$ 38
ST-251	\$320	Multi I/O XT	\$ 38
ST-251-1	\$405	Multi I/O AT	\$ 35
ST-4096	\$545	Hard Floppy Contr.	\$115

MOTHER BOARDS		DRIVES	
TMB 10MHz XT	\$ 62	Fujitsu 360K	\$ 60
TMB BABY AT 6/10 MHz	\$ 230	Fujitsu 1.2	\$ 80
AT 6/10 MHz	\$ 235	Floppy 3.5" 720K	\$ 80
AT 6/12 MHz	\$ 310	Floppy 1.44 Mb	\$115
AT 386 20 MHz	\$1,320		
AT 386 25 MHz	\$1,380		

ALL PRODUCTS ARE 100% IBM COMPATIBLE.

KEYBOARDS WE HAVE POWER SUPPLIES AND MUCH MORE.
 KB 101 \$45

A.N. Wholesale & Retail, Inc.
 1320 South Dixie Hwy. Suite 256
 Miami, Fla 33146
Phone: (305) 284-0827
Fax: (305) 284-0831

Circle 30 on Reader Service Card

8051/8052 BASIC COMPILER!

MCS BASIC52™ compatible
Runs on IBM-PC or compatible

\$ 295.00

Call Now! **603-469-3232**

Binary Technology, Inc.
 Main Street • P.O. Box 67 • Meriden, NH 03770

IN STOCK!

SIMMS

1 MEG x 9 100 NS

BEST PRICES ANYWHERE!

Major electronics mfg. 17 yrs. industry exper. will sell 1 or 1,000.

XENTEK SIMMS MART

800-748-5505

Circle 298 on Reader Service Card

EZ-WRITER

(E)EPROM Multiprogrammer™

DATA I/O 212* Performance On 1/2 The Budget!

FROM \$795
 100% USA Made



- Supports (E)EPROMs up to 40 pins including megabit and microcontroller parts
- Stand-alone or computer remote operation
- Parallel port standard
- On board RAM, expandable to 8 megabits

BYTEK 1-800-523-1565
 FAX (407) 994-3615
 TELEX 4998369 BYTEK

BYTEK Corporation Instrument Systems Division
 508 N.W. 77th Street, Boca Raton, FL 33487
 *DATA I/O is a registered trademark of DATA I/O Corporation

Circle 51 on Reader Service Card

SIBEC II



The ideal solution for embedded control applications and stand alone development.

- 8052 Basic CPU
- PROM Programmer
- ISBX™ Expansion Bus
- Highest Quality
- 1 Year Warranty

\$228.00 QTY 1
 Call Now! (603) 469-3232

Inquire about our 8051 product development kit for the IBM PC/XT/AT.

Binary Technology, Inc.
 Main St., P.O. Box 67 Meriden, NH 03770
 *ISBX is a trademark of Intel Corporation.

Circle 44 on Reader Service Card

VIDEO FRAME GRABBERS



MODEL	RESOLUTION	
HRT 256-4	256 x 256 x 4	495
HRT 256-8	256 x 256 x 8	795
HRT 512-8	512 x 512 x 8	995
HRT 512-24	512 x 512 x 24	1995

- IBM PC/XT/AT COMPATIBLE
- DIGITALIZE IN REAL TIME
- COMPOSITE VIDEO IN
- 24 BIT RGB OUT except model HRT 256-4 16 level gray scale out
- SOFTWARE LIBRARY OF IMAGE ANALYSIS ROUTINES
- FREE SOFTWARE UPGRADES TO REGISTERED OWNERS
- FULL CREDIT ON UPGRADE PURCHASE IN FIRST YEAR RETURN OLD BOARD AND JUST PAY DIFFERENCE

HRT HIGH RES TECHNOLOGIES
 P.O. BOX 76
 LEWISTON, N.Y. 14092
PHONE 416-497-6493 **FAX 416-497-1988**

Circle 125 on Reader Service Card

DELTA COMPUTING

SIMMs

1MB x 9	80 ns	\$ 299.00
1MB x 9	100 ns	279.00
256K x 9	80 ns	109.00
256K x 9	100 ns	99.00

DYNAMIC RAM

41256	80 ns	\$ 13.95
41256	100 ns	12.95
41256	120 ns	11.95
41464	80 ns	12.95
41464	100 ns	10.95

VISA **800-227-4051** M/C

MISC.

27128	8087	V20
27256	80287	V30
27512	80387	

CALL FOR CURRENT PRICES

DELTA COMPUTING TECH. CORP.

292 North Plank Rd.
Newburgh NY 12550
PH# 914-565-7080
FAX 914-565-7082

Via L. Landucci No 26
50136 Florence Italy
PH# 39 55 676 045
FAX 39 55 666 942

Circle 84 on Reader Service Card

SAVE
ON

9 TRACK TAPE SYSTEM

FOR IBM PC/XT/AT
& PS-2



- Mainframe to PC Data Transfer
- High Speed Backup
- All Software, Complete System
- Service and Support, easy Installation

call (818) 343-6505 or write to:

CONTECH Computer Corp.

P.O. Box 153 Tarzana, CA 91356

CONTECH

Circle 72 on Reader Service Card

9-Track Tape Subsystem for the IBM PC/XT/AT



Now you can exchange data files between your IBM PC and any mainframe or mini-computer using IBM compatible 1600 or 6250 BPI 9-Track tape. System can also be used for disk backup. Transfer rate is up to 4 megabytes per minute on PCs and compatibles. Subsystems include 7" or 10 1/2" streaming tape drive, tape coupler card and DOS compatible software. For more information, call us today!

QUALSTAR

9621 Irondale Ave., Chatsworth, CA 91311
Telephone: (818) 882-5822

Circle 227 on Reader Service Card



KADAK's
engineers bring years
of practical real-time experience
to over 600 installations world-wide.

This real time MULTITASKING KERNEL simplifies real life product development

- No royalties
- Full source code included
- C interface
- Preemptive scheduler
- Intertask messages
- Terminal Handler
- Dynamic memory allocation
- Event Manager
- Semaphore Manager
- Resource Manager
- Buffer Manager

AMX 68000 operates on any 68000/10/20 system

Manual only \$75 US
AMX 68000 \$1600 US

* Options — ask for price list

(Shipping/handling extra)

Also available for 8080, Z80,
8086/148/286

KADAK Products Ltd.

206 - 1847 W. Broadway

Vancouver, B.C. Canada V6J 1Y5

Telex: 04-55670

Fax: (604) 734-8114

Telephone: (604) 734-2796

Circle 140 on Reader Service Card

ON TARGET ASSOCIATES

Products and Services
for Design and Manufacturing Engineers.

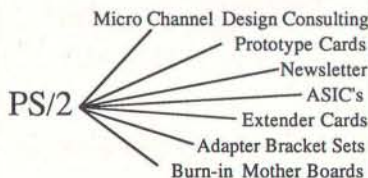

We will move your PC/XT/AT products to the
Micro Channel, or create your new design.

CALL: (408) 980-7118
for our Free catalog

**ON TARGET
TARGET
TARGET**

...the PS/2 leaders.

PS/2 and Micro Channel are trademarks of IBM Corp.

Circle 202 on Reader Service Card

LOW-LOW-LOW

hp Laserjet Printer Series II \$1650
hp Scanjet Scanner \$1355
+ interface kit

IBM **COMPAQ** **Apple** **ACER**
EVEREX **AST** & other

XT/AT Compatibles & 386 Computers
CALL for LOW PRICES

Gov't, Corporate, Schools, Dealers,
& Export INQUIRIES WELCOME.

SURAK inc.

44862 Osgood Road, FREMONT, CA 94539
PH: (415) 651-5101 FAX: (415) 651-5241
1-800-543-1001

VISA, Master Card accepted. w/sc

Circle 264 on Reader Service Card

8051 Simulator

for the IBM PC/XT/AT \$99

The 8051SIM software package assists in the debug of 8051 family programs. A screen oriented, menu command driven program, 8051SIM speeds development by allowing program execution and debug without a target system. A great learning tool as well.

8031DryICE \$199

Dry ICE is a debugger/emulator that supports the development of hardware and software using the 8031 microcontroller. The DryICE provides powerful functions to assist in the integration, debug, and test phase. Hardware connects between your target 8031 IC socket and CRT terminal or PC COM port.

HTE

HiTech Equipment Corporation
9400 Activity Road
San Diego, CA 92126

(619)566-1892

Circle 127 on Reader Service Card

Add-Ons for the Blind

What you add on to your computer, if you're a blind operator, is almost more important than the computer itself.

Scanners, modems, braille printers, speech synthesizers, braille output devices and a host of other peripherals are described in "Add-Ons: The Ultimate Guide to Peripherals for the Blind Computer User."

The product reviews contained in this book are written by those who know them best—blind computer users.

\$16.95 for braille or cassette
\$19.95 for print.

Send orders to:

National Braille Press Inc.
88 St. Stephen Street, Boston, MA 02115
(617) 266-6160

NBP is a nonprofit braille printing and publishing house.

Circle 202 on Reader Service Card



**Sure
it's insured?**

SAFWARE® Insurance provides full replacement of hardware, media and purchased software. As little as \$39/yr. covers:
• Fire • Theft • Power Surges
• Earthquake • Water Damage • Auto Accident

For information or immediate coverage call:
1-800-848-3469

In Ohio call 1-614-262-0559

SAFWARE

SAFWARE, The Insurance Agency Inc.

Circle 247 on Reader Service Card

GraphicC™

"gives you all the C language routines you need to write an impressive scientific graphing program of your own. Highly recommended."*

PC Magazine

Fresnel Integrals

$$C(x) = \int_0^x \cos(t^2) dt$$

$$S(x) = \int_0^x \sin(t^2) dt$$

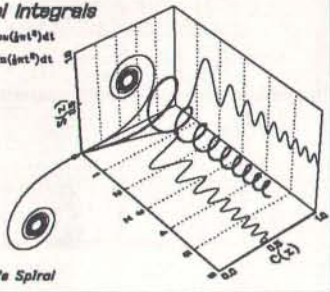

IBM® PCs (with source code) \$395. Macintosh version (no source) \$295. *For personal use only.*

VTEK™ 4.3

DEC® VT100/102/52 & Tektronix® 4010/4014/4105 Terminal Emulator

"its ease of use, high resolution graphics, emulation, and price make it a more attractive purchase than the other products."*
MINI-MICRO Systems

Only \$150

* Full reprints on request

Scientific Endeavors
508 North Kentucky Street
Kingston, TN 37763
(615) 376-4146

DYNAMIC RAMS

SIMM	80/100	\$CALL
1MBIT	100ns	\$17.50
514256	100ns	\$21.00
41464	150ns	\$ 6.95
41256	120ns	\$ 6.50
✓ 41256	150ns	◀ \$ 5.95 ▶
51258	100ns	\$ 7.50
✓ 4164	150ns	◀ \$ 2.65 ▶

* For high-speed, Zip, Pico, Simm Please Call!

PROCESSORS		EPROMS	
80387-25	25MHz \$475.00	27C101	250ns \$ 23.00
80387-20	20MHz \$385.00	27C512	200ns \$ 13.00
80387-16	16MHz \$335.00	27S12	250ns \$ 8.50
80287-12	12MHz \$285.00	27C256	250ns \$ 5.25
80287-10	10MHz \$235.00	27256	250ns \$ 4.75
80287-8	8MHz \$208.00	27128A	250ns \$ 4.50
8087-1	10MHz \$178.00	27C64A	200ns \$ 4.25
8087-2	8MHz \$135.00	2764	250ns \$ 3.50
V-30	8MHz \$ 12.75	S. RAMS	
V-20	8/10MHz \$ 8.5/15	43256	120ns \$ CALL
		4364	150ns \$ 6.95

I.C. EXPRESS

1358 Valley Blvd. City of Industry, CA 91746 Tel: 818-369-2888
ORDER TOLL FREE (Mon-Fri 8-5 PST)
(800) 892-8889 • (800) 882-8181
outside California
CALL FOR CURRENT PRICES & VOLUME DISCOUNTS.
Price Shown for cash. MasterCard/Visa and 3%. Prices are subject to change.
Minimum order \$100. Shipping & Handling: UPS Ground \$8.00, Air \$7.00 (U.S.).
ALL MERCHANDISE IS 100% GUARANTEED WITH PROMPT DELIVERY.

Circle 133 on Reader Service Card

Over 120,000 sold since 1982



Never buy another ribbon !!!
\$68.50

Universal Cartridge Maclnker
Save thousands of dollars per year and always get a perfect printout, in black or with any of our colored inks. Universal Cartridge Maclnker is \$68.50. Multicolor adapters for multicolor cartridges. We support over 24,000 printer brands & have a complete range of accessories, color cartridges, OCR, heat transfer, and indelible inks. Customers vary from individuals to Fortune 500 companies. Ask for free catalog.

Computer Friends 1-800-547-3303
14250 NW Science Park Dr., Portland OR 97229
tel. (503)626-2291 -- fax (503)643-5379

Circle 67 on Reader Service Card

IEEE 488 Solutions

- Hardware & software interfaces for PC, AT, 386, PS/2, Macintosh, SUN, HP & DEC
- IEEE converters to SCSI, RS-232, RS-422, modem, Centronics, digital I/O & analog I/O
- IEEE extenders, expanders & buffers
- IEEE drivers for DOS, UNIX®, Lotus 1-2-3, Symphony & Quattro.

Call or send for your FREE Technical Guide
Demo disks and application notes available

Please see our ad on pg. 230.



(216) 439-4091
Telex 6502830864 • Fax (216) 439-4093
IOtech, Inc. • 25971 Cannon Road
Cleveland, Ohio 44146

Circle 137 on Reader Service Card

ALL NEW !!!
9 TRACK TAPE SUBSYSTEM
for IBM PC/AT/386
complete for only
\$2,595.00
1 YEAR WARRANTY



- IBM/ANSI compatible at 800*/1600/3200 bpi
- Controller, cables and software included
- Interfaces for PS/2*, Xenix* and DEC*
- SCSI*, AT or MCA* Bus I/O at 25/50/100 ips.

AKSystems Inc.
20741 Marilla St. Chatsworth CA 91311
TEL: 818/709-8100 FAX: 818/407-5889

Circle 13 on Reader Service Card

Industrial Control Systems
Intelligent Terminals
Diskless Systems



For the IBM PC, XT, AT PS/2 and PC DOS* or MS DOS*
SOLID STATE DISKETTE AND DRIVE EMULATORS
New Dual Disk Models

- NEW PCE/2 Dual disk model—up to 1.2MB of read only EPROM memory or 770K of EPROM as the primary "boot" diskette with a secondary diskette with up to 770K of SRAM of read/write memory.
- ROMDISK PCE MODEL STANDARD FEATURES
- In-board and interchangeable Cassette models using EPROM, Flash EPROM and SRAM technology.
- On-board EPROM programmer—simply copy a diskette to program the EPROMS.
- Two Autoboot modes, a File (read) and a Programming mode—automatic disk drive designation set-up during booting.
- Flash EPROM models are electrically erasable. SRAM models are battery backed. EPROM models are ultraviolet erasable.
- List prices with memory ICs from \$295, OEM prices and models available OEM with or without memory ICs.

CURTIS, INC.
2837 North Fairview Ave. • St. Paul, MN 55113
612/631-9512 Fax 612/631-9508

*IBM PC, XT, AT, PS/2 and PC DOS are trademarks of IBM. MS DOS is a trademark of Microsoft.

Circle 78 on Reader Service Card

EPROM PROGRAMMER CROSS ASSEMBLERS



MODEL SX151

RS232C OR STAND ALONE (all models). Communication protocol: XMODEM, HEX, and BIN. Programs: EEPROMS, 2716 - 27512 and CMOS. Programs (w/adapters): 25XK, 27101 (and above), 68701, 68705, 68764/6, 8741/2, 8744, 8748/9, 8751/2, 8755, 87252, and CMOS. More available soon. Model SX151 \$214 (assembled with case). Other models are available from \$49 (kit).

Cross assemblers by PseudoCode for IBM-PCs, \$50. 280, 1802, 6502, 6800/12/3/5/8/9/11, 68000/8/10, 80489, 8051/2, 8080/5, 8096, and more soon. Simulators and disassemblers also available.



KORE, Inc.
6910 Patterson S.E.
Caledonia, MI 49316
(616) 887-1444

\$5 for shipping (USA), plus \$3.00 COD.

Circle 144 on Reader Service Card

200/100MHz Logic Analyzer



- 24 channels, Timing and State
- Optional expansion to 72 channels
- 200 or 100 MHz max sampling rate
- 16 levels of triggering
- 16K samples/channel (6 channel mode)
- TTL, ECL or Variable threshold
- 3 external clocks with 11 qualify inputs
- Data output to disk or printer
- PC/XT/AT compatible
- \$1299 - LA27100 (100MHz)
- \$1899 - LA27200 (200MHz)

Call - 201-994-6669

Link Computer Graphics, Inc.
4 Sparrow Dr., Livingston, NJ 07039 Fax: 201-994-0730

Circle 151 on Reader Service Card

Terminal emulation the right way.

ZSTEM 240

VT240/241 emulation with VT340 ReGIS, Tektronix and sixel graphics plus all the features of ZSTEM 220.

ZSTEM 220

VT220 emulation plus file transfer, 132 columns, double-high/double-wide characters and extensive network support.

Both available with the *PowerStation* - VT layout keyboard.

KEA Systems Ltd.

2150 West Broadway, Suite 412, Vancouver, B.C., Canada V6K 4L9 Phone: 604-732-7411 Fax: 604-732-0715 Order Desk: 800-663-8702

Trademarks: ZSTEM and PowerStation - KEA Systems Ltd; VT240, VT241, VT340, VT220, and ReGIS - DEC; Tektronix - Tektronics Inc.

Circle 141 on Reader Service Card

MIDI MUSIC

800 E. Campbell Road • Suite 199 • Richardson, TX 75081

Introducing...



MIDI for PC Compatibles

Convert your standard serial card into a MIDI Card in less than an hour with our MIDI Kit. Kit includes easy-to-follow instructions, parts, MIDI cables, and a MIDI recording program with C source, for only \$39.95! Serial card add \$30. Assembled and tested add \$30. Professional sequencing and scoring software also available.

1-800-456-MIDI

Circle 183 on Reader Service Card

PC-Based Programmer

PAL
EPLD
EPROM
EEPROM
MICROCONTROLLER



\$475

TI NS MMI AMD CYPRESS
ALTERA INTEL SAMSUNG...

- 20 AND 24 PIN PALS/EPLD.
- 2716-27512 EPROMS.
- EEPROMS.
- MICROCONTROLLERS (with adaptor).
- DSP TI TMS-320(with adaptor)
- Support for JEDEC, Intel Hex, Binary, and Motorola 'S' Files.
- Read, Write, Protect, and Verify.
- Full Screen Editing in Hex and Ascii.
- Byte split for 16 and 32 bit systems.

Call- 201-994-6669

Link Computer Graphics, Inc.
4 Sparrow Dr., Livingston, NJ 07039 Fax: 201-994-0730

Circle 152 on Reader Service Card

800 Pixel Windows with your EGA and the WinTerm™ EGA800

The WinTerm™ EGA800 daughterboard and driver will give your standard EGA 800 pixel resolution when running Microsoft® Windows 286.

Think of it — 56,000 more pixels with a standard EGA and enhanced color display.

Special Introductory Offer
\$59.00



2150 West Broadway, Suite 412
Vancouver, B.C. CANADA V6K 4L9
Tel: 604-732-7411 Fax: 604-732-0715
Toll Free Order Desk: 800-663-8702

WinTerm is a trademark of KEA Systems Ltd.

Circle 142 on Reader Service Card

HEAVY DUTY PC HARD CASES

MC & VISA	ADD FREIGHT HARD CASE	HEAVY DUTY HARD CASE	L.T. HARD CASE
EPSON EQUITY II CPU & KB	\$226	\$149	\$129
COMPAQ PORTABLE II	\$204	\$143	\$120
IBM AT CPU & KB	\$254	\$173	\$148
IBM MONITOR #5154001	\$226	\$154	\$129



HEAVY DUTY FOAM LINED CASES WITH COMPARTMENTS FOR KEYBOARD & MOUSE

CASES ARE AVAILABLE FOR ANY COMPUTER, ALSO CUSTOM CASES

1-800-882-7112 In MI 616-374-7105
WESTERN CONTAINER & CASE
Box 125, Woodland, MI 48897

Circle 293 on Reader Service Card

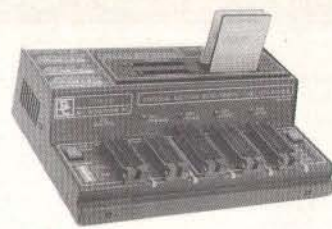

(E)PROM, MEMORY CARD & MICRO PROGRAMMER **\$345 - \$595**

- No personality modules for E(E)Proms & Intel Micros.
- All 24/28/32 pin EProms/EEProms to 4 MBIT (upgr. to 32MB).
- Flash Eproms; Micros: 8741, -2, -8, -8H, -9, -9H, -51, -C51, -52, -55 ...
- Memory Cards: Seiko/Epson, Mitsubishi, GI. Modular design.
- ON-BOARD Programming capability. Easy F/W upgrades.
- Stand-alone E(E)Prom & Memory Card Duplication / Verify.
- User friendly menu - driven driver for IBM-PC & Macintosh.
- Autobaud RS232 to any computer. Hex/Binary/Intel/Motorola.
- Built-in Eraser/Timer option (\$50). Gang-Module ready.
- Open board units starting from \$245. (OEM discounts available)
- Direct technical support. Dedicated BBS. Full 1 year warranty.

INTELLIGENT PROM EMULATOR (IBM-PC) **\$395**

- Emulates 2716 through 27512 (2k to 64k bytes) with a single unit
- Intelligent features include: Reset Output, Address Compare, Address Snapshot, Trigger Input, Program Editing capabilities.
- FAST data loading via parallel port (64k bytes in less than 10sec)
- After loading program unit can be disconnected from host for stand alone operation (9V battery backup).
- User friendly software; Functions include: Load, Write, Display, Edit, Monitor, Help, Calculator, Reset and more.
- Cascadable up to 8 units. Selectable wordsizes.
- Accepts Binary, Intel Hex and Motorola S formats.

MC/VISA/AMEX

Call today for datasheets!



B&C MICROSYSTEMS INC.

355 WEST OLIVE AVE. SUNNYVALE, CA 94086
TEL: (408)730-5511 FAX: (408) 730-5521

LOW COST INTERFACE CARDS FOR PC/XT/AT/PS2

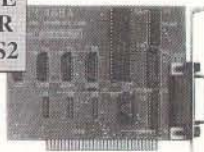

RS-485/422 Card [PC485] \$95/125

- Serial Async. Communication up to 4,000ft; 2 or 4 wires; NS16450 UART.
- Can be configured as COM1-COM4; Maximum Band Rate 56Kb/115Kb.
- Dual drivers/receivers; Handles 64 devices; Compatible with most comm. stwr.
- DB9 or phonejack. Sample communication software available - \$50/150

IEEE-488 Card [PC488A] \$145

- Includes INSTALLABLE DOS DEVICE DRIVERS and support for BASIC.
- Additional Support for ASSEMBLY, C, Pascal and FORTRAN - \$50.
- IRQ (1-6). DMA channel 1 or 2. Up to 4 boards per computer.
- Compatible with most IEEE-488 Software packages for IBM-PC (e.g. ASYSTANT-GPIB, Lotus Measure). Compatible with NT's GPIB-PCIIA.

IEEE-488 Card [PC488B] With Built-In Bus Analyzer \$345

- Software Support for BASIC, QuickBASIC and GWBASIC.
- Additional libraries for C, Pascal, FORTRAN, Assembly available - \$95 (all)
- Powerful menu-driven BUS ANALYZER runs in the background while 488 programs or commands are executed; Features Program Stepping, Break points, real time bus data capture (4K buffer), instant screen toggling.
- Complete Controller / Talker / Listener capability. Based on TI's TMS-9914.
- NEC-7210 based card (compatible with Nat. Instruments PCII/PCIIA) - \$445.

PS2 Ser/Par Card [PS2IOA] \$95/125

I/O card for PS2 Models 50-80; Ser. port 1-2; Par. port 1-3; IBM registered ID

A/D + D/A + DIO + Counter \$295-995

- Input channels: 16 single, 8 differential; A/D Resolution: 12 to 14 bits;
- Conversion speed 25,000 - 100,000 samples/sec; Input Range (+/-) 1 - 10V
- D/A: 2 channels; Resolution: 12 to 14 bits; Settling time: 5µsec. Range: 0-5V
- Digital I/O: 16 Out, 16 In; TTL compatible; Counter: 16 bits programmable.
- Compatible with ASYST, LABTECH, UnkelScope, DADISP.

MC/VISA/AMEX

Call today for datasheets!



B&C MICROSYSTEMS INC.

355 WEST OLIVE AVE. SUNNYVALE, CA 94086
TEL: (408)730-5511 FAX: (408) 730-5521

Circle 36 on Reader Service Card

DISCOVER US!**RIBBONS**

Apple Imagewriter	\$2.80
Brother HR15/25(ms)	\$2.55
Citizen 120D/180D	\$4.25
Commodore 801	\$2.80
Diablo Hytype II(ms)	\$1.90
Epson EX 800/1000	\$6.00
Epson MX,RX,FX-70/80/85	\$2.70
NEC P2/P6	\$4.75
NEC P3/P7	\$5.00
Okidata 293/294	\$8.00
Okidata 182/192/320/321	\$4.25
Okidata 80/82/S. Gemini 10	\$1.00
Okidata 84	\$3.50
Panasonic KXP-1090	\$3.50
Star NX/NP/ND-10/NB24-10	\$4.30
Toshiba 1350/351/341/(HD)	\$3.50

Many other ribbons available.

29¢ BULK DS/DD DISKS

each, 100 or more

33¢ each, less than 100.

38¢ WHITE BOX (10 per box) less than 10 boxes

In 17 colors (lot of 20) 45¢ each, less than 100

59¢ BULK HD/AT

each, 100 or more

63¢ each, less than 100.

68¢ WHITE BOX (10 per box) less than 10 boxes

In 8 colors (lot of 20) 94¢ each, less than 100

99¢ BULK 3.5 DS/DD

each, 100 or more

\$1.07 each, 50 or more. \$1.11 each, less than 50.

\$1.16 each, WHITE BOX less than 100.

In 8 colors (lot of 10) \$1.28 each, less than 50

\$2.95 BULK 3.5 HD/AT

each,

MINIMUM OF 10

\$3.00 each, WHITE BOX, 10 per box

\$3.25 BULK 3.5 HD/AT

each,

MINIMUM OF 10

\$3.30 each, WHITE BOX, 10 per box

CONTINUOUS FORM LABELS

Size	Across	Box Qty.	Price/1,000
2 3/4 x 7/16	1 across	10,000	\$2.05
2 3/4 x 7/16	4 across	20,000	\$2.05
2 1/2 x 15/16	1 across	5,000	\$2.40
2 1/2 x 15/16	3 across	15,000	\$2.30
2 3/4 x 2 3/4	1 across	1,000	\$16.00
2 3/4 x 2 3/4*	1 across	2,500	\$12.00
2 3/4 x 1 7/16	1 across	5,000	\$3.75
3 x 15/16	4 across	20,000	\$2.10
3,3 x 15/16	4 across	20,000	\$2.15
3 1/2 x 15/16	1 across	5,000	\$2.00
3 1/2 x 15/16	2 across	10,000	\$2.00
3 1/2 x 15/16	3 across	15,000	\$2.00
3 1/2 x 15/16	4 across	20,000	\$2.00
4 x 15/16	1 across	5,000	\$3.50
4 x 15/16	3 across	15,000	\$3.50
4 x 1 7/16	1 across	5,000	\$3.55
4 x 1 7/16	3 across	15,000	\$3.55

Many other sizes available. Call for further information.

Designed for the 3 1/2" disk. Prices quoted for full boxes only.



1040 Broadway, Westville, NJ 08093 & Fresno, CA.

1-800-426-3303

Orders less than \$150. add \$4.50 shipping and handling charge, Continental USA only.

C.O.D. add \$2.75. Orders over \$150. we charge actual UPS charges. Purchase orders, VISA and MasterCard accepted.

All orders F.O.B. Westville, NJ and Fresno, CA. For faster service & delivery, all West Coast orders are shipped from Fresno, CA.





of Discounting
Computers, FAX
& Cellular Phones

Radio Shack® Tandy®
SCO

We will meet or beat...
GUARANTEED LOWEST PRICES

MARYMAC INDUSTRIES INC.
22511 Katy Fwy.
Katy (Houston), TX 77450
1-713-392-0747 FAX (713) 574-4567
Toll Free 800-231-3680

Circle 162 on Reader Service Card

TISAR-PC
(Pronounced TY-ZAR)

INVOICING





Keep records the way big business does...
(Hard drive required)

FULLY INTEGRATED Remarkable Turn-Key System

- Data-base
- Invoicing
- Inventory control
- 3,000 records per file
- 12,000 invoices per file
- Accounts receivable
- Accounts receivable
- Customer statements
- Mailing labels

LIMITED OFFER
\$79.00

Now with point of entry pricing and user definable fields.

Search, cross-search, fast sorts, reports and much more.

Much easier than Dac-Easy, Peachtree, etc.

IDEAL for service or sales/mktg businesses. Easy, menu-driven, user friendly, fully tested. Up and running in under 3 minutes. Free customer support... Easy documentation.

CALL 1-800-537-LABS or ask your dealer.

COD gladly accepted





10610 Evans Street Philadelphia, PA 19116 Dealer inquiries invited

Circle 52 on Reader Service Card

PC
MULTI-LINE



POWER LINE

EDITOR'S CHOICE

VOICE MAIL

- ◆ Voice Mail System
- ◆ Call Processing
- ◆ Telemarketing
- ◆ Order Processing
- ◆ Call Distribution
- ◆ Programmers Tool Kit

Complete Systems

BIG MOUTH. \$295

Starting at ... PLUS 6 S/H

(415) 652-9600

TALKING TECHNOLOGY, INC. 

4383 PIEDMONT AVE., OAKLAND, CA 94611

Circle 266 on Reader Service Card

Terminal Emulation**TEK 4105/4010**

- Tektronix 4105
- Tektronix 4010/4014
- VT220, VT102
- Picture files
- VGA and EGA support
- High resolution hardcopy

VT220

- VT220, VT102 emulation
- File transfer
- 132 column modes
- Color support
- Hot key

■ ■ ■ **Diversified Computer Systems, Inc.**

3775 Iris Avenue, Suite 1B
Boulder, CO 80301 (303) 447-9251
FAX 303-447-1406

Trademarks: VT102, VT220 — DEC; Tektronix — Tektronics Inc.

Circle 90 on Reader Service Card

9-TRACK TAPE SYSTEMS!

OVERLAND DATA IS THE EXPERT when it comes to connecting your PC to the mainframe and mini computer world.

- PC/XT/AT/386/PS2/compatibles
- 800, 1600, 3200, 6250 BPI
- Free tutorial on tape systems
- EBCDIC/ASCII conversion
- IBM & ANSI labeled tapes
- DOS, XENIX, UNIX, PICK
- Highest quality customer service
- Stock full range of tape drives
- Network backup and More!

Overland Data Inc.

5620 Kearny Mesa Rd. • San Diego, CA 92111
Tel: (619) 571-5555 • FAX: (619) 571-0982

Circle 203 on Reader Service Card



Presto!
A Link to Mainframe Graphics

Find out how our whole family of EMU-TEK graphics terminal emulation software makes good sense for the work you do. Call today for more information.

FTG DATA SYSTEMS

(714) 995-3900
(800) 962-3900 (800) 972-3900 (Calif.)
10801 Dale St., Suite M-2
Stanton, CA 90680

Circle 106 on Reader Service Card

A-BUS™ MAGIC

Classroom to advanced industrial applications.

Be a Wizard in your Lab, Factory, College, Home...

It used to be difficult and costly to do process control, robotics, data acquisition, monitoring and sensing with your computer. Now the low-cost A-BUS system makes it easy to do almost any project you can imagine.

Versatility. A-BUS cards handle most interfacing, from on/off switching, to reading temperatures, to moving robot arms, to counting events, to sensing switches...

Adaptability. The A-BUS is modular, allowing expansion well beyond your needs. It works with almost any computer, or even as a remote data station with the new serial adapters.

Simplicity. You can start using the A-BUS in minutes. It's easy to connect, and software is a breeze to write in any language.

Reliability. Careful design and rugged construction make the A-BUS the first choice in specialized I/O.

An A-BUS system consists of: - An A-BUS adapter plugged into your computer - A cable to connect the adapter to 1 or 2 A-BUS function cards. - The same cable will also fit an A-BUS Motherboard for expansion to up to 25 cards in any combination.

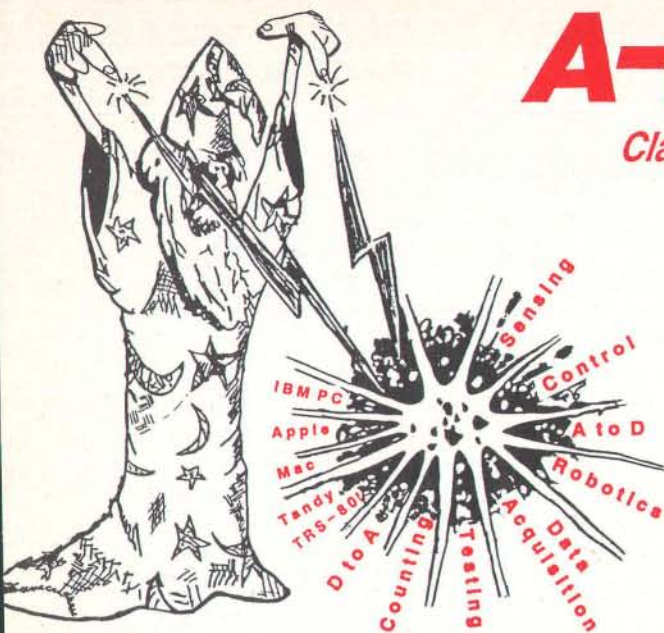

NEW: REMOTE A-BUS! Use the new Serial (RS-232) Adapter or Processor to control any A-BUS system. Cards can be up to 500 ft away using phone type cable, or off premises using a modem. Call or send for the new A-BUS Catalog which covers all the products.

Important

All A-BUS Systems: ♦ Come assembled and tested ♦ Include detailed manuals with schematics and programming examples ♦ Can be used with almost any language (BASIC, Pascal, C, assembler, etc.) using simple "IN" and "OUT" commands (PEEK and POKE on some computers) ♦ Can grow to 25 cards (in any combination) per adapter ♦ Provide jumper selectable addressing on each card ♦ Require a single low cost unregulated 12V power supply ♦ Are usually shipped from stock. (Overnight service is available.)

About Alpha Products

Founded in 1976 for the purpose of developing low cost I/O devices for personal computers, Alpha has grown to serve over 70000 customers in over 60 countries. A-BUS users include many of the Fortune 500 (IBM, Hewlett-Packard, Tandy, Bell Labs, GM...) as well as most major universities. A-BUS products are U.S. designed, U.S. built, and serviced worldwide.

Overseas distributors: England: Cady Science Assoc. Ltd., Merseyside, 051 342 7033.

Australia: Brumby Technologies Pty. Ltd., NSW, 759 1638. France: Coserm, Rungis, 46 86 64 75

Inputs, Outputs, etc.

Analog Input: 8 analog inputs. 0-5.1V in 20mV steps (8 bits). 0-100V range possible. 7500 conversions/second. **AD-142: \$142**

12 Bit A to D: Analog to digital converter. Input range -4V to +4V, expandable to 100V. On-board amplifier. Resolution 1mV. Conversion time 130ms. 1 channel. (Expand to 8 channels with the RE-156 card.) **AN-146: \$153**

Relay Card: 8 individually controlled industrial relays each with status LED's (3A at 120VAC contacts, SPST). **RE-140: \$142**

Reed Relay Card: 8 reed relays (20mA at 60VDC, SPST), individually controlled and latched, with status LEDs. **RE-156: \$109**

D/A converter: 4 Channel 8 Bit D/A converter with output amplifiers and separate adjustable references. **DA-147: \$149**

24 line TTL I/O: Connect 24 input or output signals (TTL 0/5V levels or switches). Variety of modes. (Uses 8255A) **DG-148: \$72**

Digital Input: 8 optically isolated inputs. Input can be 5 to 100V voltage levels or switch closures. **IN-141: \$65**

Digital Output Driver: 8 outputs: 250mA at 12V. Drive relays, solenoids, stepper motors, lamps, etc. **ST-143: \$78**

Clock with Alarm: Powerful clock/calendar. Battery backup. Timing to 1/100 sec. Alarm relay, LED and buzzer. **CL-144: \$98**

Touch Tone Decoder: Each tone is converted into a number which is stored on the board. **PH-145: \$87**

A-BUS Prototyping card: 4x4.5" card. Will accept up to 10 C.s. With power & ground bus. **PR-152: \$16**

Counter Timer: Three 16 bit counters/timers. Use separately or cascade for long (48 bit) counts. **CT-150: \$132**

Motion Control

Smart Quad Stepper Controller: The world's finest. On board microprocessor controls four motors simultaneously. Uses simple English commands like "MOVE ARM 10.2 (INCHES) LEFT". For each axis, you control coordinates (absolute or relative), ramping, speed, units, scale factors, etc. Many inputs for limit switches, etc. On the fly reporting of speed, position... Built in drivers for small motors (such as MO-103 or 105). **SC-149: \$299**
Options: ▶ 5 amp/phase power booster for 1 motor: **PD-123: \$49**
▶ Remote "teach" keypad for direct motor control: **RC-121: \$54**

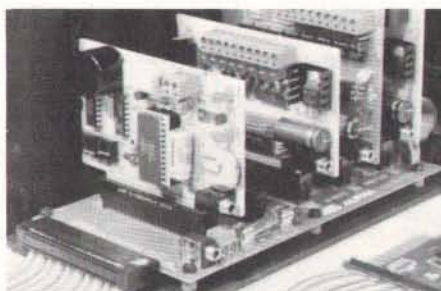

A large A-BUS system with two Motherboards. Adapter in the foreground plugs into PC XT/AT type slot.

Stepper Driver Kit: For experimenting with stepper motors. Includes 2 MO-103 motors and a ST-143 dual driver **PA-181: \$99**

Stepper Motors: (4 phase, unipolar)
MO-103: 2 1/4" dia. 1/4" shaft, 7.5"/step, 12V, 5 oz-in torque. **\$15**
MO-104: 2" dia. 1/4" shaft, 1.8"/step, 5V, 60 oz-in torque. **\$45**
MO-105: 1.7" square. 2" shaft, 3.75"/step, 12V, 6 oz-in. **\$15**

A-BUS Adapters

- ▶ Can address 64 ports and control up to 25 A-BUS cards.
- ▶ Require one cable. Motherboard required for more than 2 cards.

A-BUS Parallel Adapters for:
IBM PC/XT/AT & compatibles. Uses one short or long slot. **AR-133: \$69**
Apple II, II+, IIe Plugs into any slot inside. **AR-134: \$52**
Commodore 64, 128 Plugs into Expansion Port on back. **AR-139: \$48**
TRS-80 Model 102, 200 Uses 40 pin "System bus". **AR-136: \$76**
Model 100 (Tandy portable) Plugs into socket on bottom. **AR-135: \$75**
TRS-80 Model 3, 4, 4D Y-Cable available if 50 pin bus is used. **AR-132: \$54**
TRS-80 Model I Plugs into 40 pin expansion bus. **AR-131: \$39**
Tandy Color Computers Fits ROM slot, Multipak or Y-Cable **AR-138: \$49**

A-BUS Cable: Necessary to connect any parallel adapter to one A-BUS card or to first motherboard. 50 pin, 3 ft. **CA-163: \$24**
Special Cable for two A-BUS cards **CA-162: \$34**

Serial Adapter: Connect A-BUS systems to any RS-232 port. Allows up to 500 ft from computer to A-BUS. **SA-129: \$149**

Serial Node: To connect additional SA-129/A-BUS systems to a single RS232 serial port (max 16 nodes). **SN-128: \$49**

Serial Processor: same as above plus built in BASIC for off-line monitoring, logging, decision making, etc. **SP-127: \$189**
Use SA-129 or SP-127 with modems for remote data acquisition.

Motherboard: Holds up to 5 A-BUS cards in sturdy aluminum frame with card guides. A sixth connector allows (using cables CA-161: \$12) additional Motherboards to be added. **MB-120: \$108**

Power Supply: Power pack for up to 4 cards. **PS-126: \$12**

Complete Catalog Available
For Orders and Info call (203) 656-1806
Weekdays from 9 to 5 EST or FAX 203 656-0756

Call our application engineers to discuss your project.

Ordering Information: We accept Visa, Mastercard, Checks, and M.O. C.O.D. is \$4 extra. Purchase orders are subject to credit approval. CT residents add 7.5% sales tax. Shipping: \$4 per order (usually UPS ground). UPS 2nd Day Air: \$4 extra. Next Day service available. Canada: \$6 per order (Airmail). Outside US and Canada: Add 10% of order total.

Circle 15 on Reader Service Card



a Sigma Industries Company

ALPHA Products

242-B West Avenue, Darien, CT 06820

JUNE 1989 • BYTE 365

**NEW
LOW
PRICES**

nitex

COMYSON

Special of the Month
SIMM 1MG X9-100 NSonly \$219

ESTABLISHED 1976

**SIMM-SIPP
MODULES**

1 MG X 9-for IBM TYPES
1 MG X 9-120 NS...\$199
1 MG X 9-100 NS...\$219
1 MG X 9-80NS...\$249
1MG X9-70NS...\$319

256 X 9- for IBM TYPES
256 X 9-120NS\$59
256 X 9-100NS\$79
256 X 9-80NS\$99
256 X 9-70NS\$119

1 MG X 8 - for APPLE
1 MG X 8-120NS ...\$179
1 MG X 8-100NS ...\$199

256 X 8 - for APPLE
256 X 8-120NS\$59
256 X 8-100NS\$69

PS-2 SIMM'S

256 X 9 (FOR PS2)
256 X 9-120NS\$99
256 X 9-100NS\$109

MODEL 30-286

1 mg x 9-100\$279

PS-2MODEL 70&80 SIMM

1 MG X 9-100NS ...\$289
1 MG X 9-80NS...\$349
2 MG X 9-80NS...\$679

Daughter BD Mod 70-80

1 mg (6450375) ...\$525
2 mg (6450379) ...\$999

DIP

ZIP

SDJ

SIMM

SIPP

PS-2
SIMM

MATH-CO

D-RAM

1 MG X 1
1 MG X 1-120 NS\$15.00
1 MG X 1-100 NS\$16.50
1 MG X 1-80NS ..\$21.00

256 X 1
256 X 1-150 NS ...\$5.85
256 X 1-120 NS ...\$6.50
256 X 1-100NS ...\$6.95
256 X1-80NS\$7.50
256 X 1-60NS\$9.00

256 X 4
256 X 4-120 NS . \$18.00
256 X 4-100 NS . \$19.00
256 X 4-80NS ...\$23.50

64 X 1
4164-150NS\$1.75
4164-120NS\$2.35
4164-100NS\$2.55

64 X 4
4464-150 NS\$7.00
4464-120 NS\$8.50
4464-100NS\$9.50
4464-80NS\$11.00

256 X 4 SC
514258-10\$25

256 X 1 SC
51258-10\$7.50
51258-80\$9.00
51258-70\$9.50

Compaq 386 Memory
1 mg-expansion ...\$399
4 mg.....\$1399



MATH CO-PRO

8087-3(5MHZ)\$89
8087-2(8MHZ)\$120
8087-1\$170
80287-6\$130
80287-8\$195
80287-10\$218
80C287-12\$299
80387-16\$320
80387-20\$380
80387-25\$475

CPU CHIPS

8088\$5.00
80386-16\$189
80386-20\$289
80386-25\$439
V-20 (8MHZ)\$7.50

**VIDEO RAM
FOR VGA CARDS**

64 x 4(150NS)\$10
64 x 4(120ns)\$12
64 x 4(100ns)\$18

D-RAM TESTER

only \$249-\$169
Tests the following memory chips:
64K X 1 256 X 1
64K X 4 256 X 4
4M X 1 1M X 4
The RTI can help anyone come through the frustrating process of identifying bad (or good) D-RAM chips. The weight and durability of the tester, make portability a breeze, whether it be on site, in the lab or in your tool kit. Don't be caught without one!

MEMORY EXPANSION BOARDS

AST

Advantage 2 - Expands to 3MB with 512 K ... \$479.00
has SER/PAR Software
Uses 256K RAMS
Advantage 2-386 for PS2 Model 70/80 \$819.00
Expands to 8 MG
has SER/PAR
Uses 256 or 1MG SIMMS
Rampage 286-For AT\$319.00
Expands to 2 MG with 512 K
Uses 256 RAMS
Rampage Plus 286-For AT\$569.00
Expands to 8 MG with 512 K
6 PAK Plus-For PC/XT\$118.00
Expands to 257K (with 64 K)
Has PAR/SER/CLK Software\$248.00
Uses 64K or 256K RAMS

BOCA RESEARCH

For PS2
Bocaram 30- with 0K RAM\$129.00
Expands to 2MG
Uses 1MG X 1 D-RAMS
Bocaram 50/60 with 0K RAM\$179.00
Expands to 4 MG with Software
Uses 1 MG X 1 D-RAMS
Bocaram MCA 50Z with 0K RAM\$189.00
Expands to 2 MG
Uses 1 MG X 1 D-RAMS
BOCA MCA Parallel Card\$99.00
BOCA MCA Serial/PAR\$169.00

EVEREX

Mini-Magic - #EV138 - 576K Memory Card\$59.00
for PC & AT with 0K
Uses 64K & 256K D-RAM
RAMII 4000 - #EV-136 - 4MB EMS\$249.00
Extended Memory card with 0 K
Uses 1 MGD-RAMS

IBM

1497259 - For PS-2MOD 50/60\$499.00
with 0K Expands to 8 MB
Uses 256K SIMMS (IBM only)
6450605 - For PS-2MOD 70/80\$1329.00
with 2 MG Expands to 8 MB
Uses 2MG SIMMS (IBM only)
6450203 - For AT - Has 512K RAM\$129.00

IDEA ASSOCIATES

IDEA max 80 - for PS2 MOD 70/80\$299.00
Expands to 8 MB
Uses 256K of 1 MG SIMMS
IDEASupermax/MC - for PS2 MOD 50/60\$319.00
Expands to 8MB/2 Extended memory/2SER/EMS
Uses 256 or 1 MG SIMMS
IDEAmax/MC - for PS2 MOD 50/60 & 80\$239.00
Expands to 12MB Extended
memory with software
Uses 1MG or 2MG SIMMS

UNITEX

3MG Multifunction - for AT\$149.00
Expands to 3MG - has SER/PAR PORT
Uses 1MG D-RAMS
386 Multi-function Card for PC/XT\$89.00
Expands to 384K
has SER/PAR/CLK/Game port
Uses 64K or 256K D-RAMS
PS-2 MEM for PS2-MOD 70/80\$99.00
Expands to 8 MB
Uses 256 or 1MG SIMMS

VIDEO ADAPTER

AT1

EGA Wonder 800\$169.00
Supports EGA, MDA, CGA & Hercules
VIP VGA - 800 X 560 -\$275.00
Supports VGA, CGA, MDA & Hercules

VIDEO 7

Fastwrite VGA\$349.00
256 D-RAM, 800 X 600, 640 X 480
Supports VGA/EGA/MDA/CGA & Hercules
V-RAM VGA\$519.00
256 K V-RAM, 1024 X 768, 800 X 600
VEGA Deluxe\$239
640 X 480 Multi-sync
VEGA Pro\$319.00
800 X 600 Multi-Sync

ORCHID

Designer 800 VGA\$269.00
800 X 600 - 16 Colors
Prodesigner\$339.00
Supports 1024 X 768 - 16 Colors
Pro Designer Plus\$449.00
Same as Prodesigner
Has downloadable fonts

UNITEX

Monochrome Graphics Card\$46.00
with par port • MDA/CGA/Hercules
Colorgraphics Card\$46.00
RGB Color with Par Port • EGA/MDA/CGA/Hercules
EGA Card\$268.00
640 X 480, 16 Colors, EGA/MDA/CGA/Hercules
VGA Card\$268.00
600 X 800, 16 Colors • VGA/EGA/MDA/CGA/Hercules

TERMS AND CONDITIONS

No Surcharge for MC/VISA Terms: MC • VISA • COD • CASH • AMEX add 4%
Purchase Orders from qualified firms 20% restocking fee on non-defective returns
Prices Subject To Change



2852 F Walnut - Tustin, CA 92680
Phone: 714/730-5232 • FAX#: 714/838-8593



TOLL FREE OUTSIDE CA: 1/800/533-0055

TIMELINE INC.

ORDER DESK ONLY

Continental U.S.A. (800) 872-8878
 Inside California (800) 223-9977

L.A. & Technical Info. (213) 217-8912

OEM INQUIRIES WELCOME

16 Characters x 1 line Dot Matrix Liquid Crystal LIQUID CRYSTAL DISPLAY

- MFG: Optrex • 5v power required • C-MOS/TTL compatible signal level • Built-in RAM for display data storage • Multiple instruction set (based on 13 commands) • Built-in C-MOS LCD driver & controller • Easy "Microprocessor" interface • Low power consumption • 5x11 dot matrix formation with cursor, alphanumerics & special symbols • 98 ASCII character generator (plus 64 katakana) • 8 programmable characters • ribbon cable connector already wired • Unit is backlit.

Physical size 3-1/8" L x 1-3/8" W x 1/4" D



3 for \$30 (Repeat of a sellout)

\$55

360K/720K FLOPPIES

\$60

1/2 Ht. 360K 5 1/4" DS/DD
 NEC Model 1053

1/2 Ht. 720K 3 1/2" DS/QD
 NEC Model 1035

PERSYST™ MONOCHROME DISPLAY AND MULTIFUNCTION CARD FOR IBM PC/AT

This card has 1 serial port and 1 parallel port. It can be expanded to 1.5MB memory. This card has extended memory only. (This is not EMS or EEMS.)

You can attach a monochrome monitor to the card as well as hook up a lightpen.

Also includes utility software: drive emulator, printer spooler, utility to control calendar/clock.

Uses 64K or 265K chips. Has (18) 4164-200 chips on board (128K).

\$49.00

85MB Full Height Drive

Maxtor 1085

28 ms access time
 RLL compatible

\$499.00

VGA PACKAGE Special Price \$549

800x560 in 16 colors 300x200 in 256 colors 640x480 in 16 colors
 Fully VGA, EGA, CGA, Hercules™ and monochrome graphics compatible
 UPGRADES ANY XT OR AT to VGA GRAPHICS—

This is an IBM style analog monitor. The card is an ATI improved VIP Card. The package comes with user friendly manual and step-by-step instructions. One year warranty on the monitor. Two year warranty on the card.

- Max resolution (800x560)
- Bandwidth: 17 Mhz
- Software selectable to VGA, EGA, CGA, MDA, HGA
- Anti-reflective, coated non-interlace, flicker free screen
- 31 dot pitch
- Call for quantity discounts

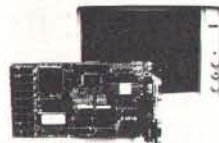

ZENITH 7" MONITOR

Model DJ7NK2
 HIGH RESOLUTION AMBER

Diagonal Screen

NEW!
 IN BOX

- Flat faceplate
- 900 lines at center/650 lines at corners
- Operates from 12VDC at 1.4 amp
- Verticle input is 47 to 63 Hz
- Horizontal frequency: 15 Khz (adjustable)



22 MHZ TYPICAL BANDWIDTH

For split video (TTL inputs) operation. Not composite video.

\$29.95
 4 for \$99

Liquid Crystal Display Graphic and Alphanumeric 480 Dot (W) x 128 Dot (H)

This is a very high quality device. Microprocessor interface easily accomplished with supporting circuitry. Offers bit map graphics as well as text. Other applications not tied to microprocessors are possible.

- Driving voltages all available from microprocessor port
- CMOS TTL compatible signal level
- Built-in RAM for display data storage
- Comes with built-in CMOS LCD driver and controller
- Low power consumption
- 480 dot x 128 dot (pixel) matrix formation
- Supports full ASCII character set and extended character set
- Character size: 5x7 or 7x9
- Package price includes LCD and driver board

Dimensions:
 10.6" L x 4.3" W
 x 4/100" D

\$99

60 MB TAPE CARTRIDGES

555 ft. \$19.95 each
 10,000 ftpi 17.95 3-9
 \$15.00—10 or more

DC300 (these are not the XL version. 30 Mb only) \$10.00 each
 DC1000 \$5.00 each

5 INCH COMPOSITE AMBER MONITOR

Unit is non-enclosed with chassis around it. Excellent resolution comes with pin-out.

\$55.00

HIGH POWERED 3-D GRAPHICS FOR YOUR IBM PC VECTRIX™ COLOR CARD

Included: Board, manual and driver software.

- Features:
- 9 color planes, 672x480 pixels.
 - 20 & 30 operation modes, 4096 colors.
 - Also emulates IBM CGA card.
 - On-board processors—Intel 80188 and Nec 7220.
 - 75 high-level graphics commands in firmware.
 - Character-like commands generates by I/O statements in high level language used to control graphics operation.

Compatible with Auto—CAD.
 (Note: Card uses 2-8 bit slots) **\$350.00**

POWER SUPPLY BLOWOUT!

YOUR CHOICE **\$12.00** Minimum 2 per Order

Please check dimensions. These are open frame supplies.

Compower 130 Watt supply. Unit is open framed.
 Output: +5V @ 5A, +12V @ 3A, -12V @ .5A, +12V @ 5A
 Dimensions: 8 1/2" L x 4 3/4" W x 2 1/2" H

Power Systems—180 Watt supply.
 Unit is open framed with 2 four pin power connectors built onto the unit.

Output: +5V @ 20A, +12V @ 4A, -12V @ 5A
 Dimensions: 9 3/8" L x 4 3/8" W x 2 1/2" H

Minimum Order: \$20.00. Minimum shipping & handling charge \$5.00. We accept cashiers checks, MC or VISA. No personal check COD's. California residents add 6 1/2 % sales tax. We are not responsible for typographical errors. All merchandise subject to prior sale. phone orders welcome. Foreign Orders require special handling. Prices subject to change without notice. FAX (213) 532-6304.

TANDON 8" 1/2 HT. DRIVES 848-2 \$180.00

Minicassette Tape Unit Hobbyist's Delight

All metal, high precision reversible tape deck. Operates at 9 to 12 Volts DC. (This is a digital device.) Excellent motor drive and gear reduction unit. Originally used as a computer input/output device.

Includes Complete Schematics **\$19.00**



FULCRUM TRACK BALL



- Stationary Mouse
- PC Magazine Editors First Choice for CAD Use
- New Menu Key • Does Lotus 123, Wordperfect or your own menus

\$89

ROBOTIC LENS

Great source of optical and electro-mechanical parts and systems including the basis for an infrared communications system.



Contains f1.4-12 to 72 mm (6x) zoom lens with macro capability. DC motor driven or manual zoom and focus systems with precision gear reduction units, mechanical clutches, and high quality DC motors, DC rotary actuator controlled iris diaphragm unit.

\$19.00

TIMELINE

1490 W. ARTESIA BLVD, GARDENA, CA 90247

Order Desk Only (800) 223-9977
 OEM Inquiries Welcome (800) 872-8878
 L.A. Area & Technical Info. (213) 217-8912



15% Restocking fee for returned orders.

**The ALL
NEW!**

S-100 EXPRESS

Ad Code
BI-E9

Since 1977

PC SYSTEMS

AST BRAVO/286.....CALL
AST Premium/286 - Model 80.....CALL
AST Premium/386 - Model 300.....CALL

FastData Systems

FDS XT
10Mhz, 640k, S, P, G, C, MGP Card, 360k Floppy,
AT-style Keyboard, Front Panel Controls &
LED's.....\$525

FDS "Baby" AT
12Mhz, 1Mb, 5HH Drive Bays, HFD Ctrl, 1.2 Mb
Floppy, S, P, C, 101 KB.....\$975

FDS 386 "TOWER"
20 Mhz, 1mb, 5 HH Bays, HFD Ctrl, 1.2 floppy, 2S,
P, 101 Keyboard.....\$1,698

Indtech "Industrial strength Tower Systems".....CALL

LAPTOPS

MITSUBISHI MP286L 12mhz, 0 wait, 640K, 11"
white screen CGA, HGC Ext Video adptr, 1.44Mb
floppy, 20Mb hard drive, 2 ser/1 par. cl/cal, ext
floppy ports, 4 proprietary
slots, DOS 3.3, G.W. Basic.....\$2,449

MP286L with 40Mb Drv & EGA adptr.....\$2,888

Zenith 5586-20Mb.....\$2,479
Zenith 55286-40Mb.....\$3,858

MONITORS & TERMINALS

SAMSUNG EGA 14" tilt 'n' swivel.....\$ 379
SAMSUNG Amber 12" T'n'S.....\$ 79
SAMSUNG CGA 14" T'n'S.....\$239

TATUNG CM -1495 OmniScan 14" Multi-freq.,
800x600, VGA, EGA, CGA, w/VGA card...\$739
TATUNG CM - 1496 VGA 14" w/VGA cd\$ 699

MDS "The Genius" FULLPG. for PC/XT/AT.....\$749

MITSUBISHI DiamondScan 14" T'n'S.....\$549

MONITERM 19" & CARD for SUPER HI-REZ.....CALL

NEC Multisync 3D.....\$749

XTRON - Futuristic & non-glare w/soft white,
EGA, VGA & Multisync models (AST OEM), from

Amb 14" flat \$119...to 14" multisync \$539

ZENITH FTM - 1490 VGA flat screen.....\$ 599

Televideo 905G.....\$298
WYSE WY-60 w/keyboard.....\$ 425

PRINTERS, PLOTTERS, & FAX

BROTHER M-1109 Narrow 120 GPS.....\$ 149
BROTHER M-1709 220 cps Wide.....\$ 359
BROTHER 2024L 24 Pin Wide/Trac.....\$ 329
Brother cut-sheet-feeders at super low \$\$

HOUSTON INSTRUMENT
PLOTTERS DIGITIZERS.....CALL

SUMMA SKETCH 12X12.....\$ 359

FAX

XEROX 7017SF store & forward.....CALL
Packard-Bell.....\$849

LASER PRINTERS & SCANNERS

Brother HL-8e 40 fonts
8PPM 2nd gen. Canon Engine
Emulates Epson, IBM, Diablo
1Mb RAM=Full Pg graphics
HP Laser Jet Plus compatible

EVEREX POSTSCRIPT LASER.....\$CALL
H.P. LaserJet Series II.....\$CALL
Font Cartridges From.....\$ 119
Panasonic 4450 Laser dual tray, 11PPM.\$1,449

DRIVES - HARD, FLOPPY, & TAPE

EVEREX 60Int. - 60Mb int. tape w/soft.\$798
EVEREX 125Mb internal tape.....\$998

CDC 90Mb HH SCSI.....\$888
CDC 155 FH SCSI.....\$1,479
CDC 300 FH SCSI.....\$2,099

MAXTOR XT-1240R 183 Mb RLL.....\$1,695
MAXTOR XT-4380E & ESDI Ctrl..\$2,539

MICROPOLIS 1335 85Mb 28mSEC.....\$ 549
MICROPOLIS 1578 332Mb W/SCSI Ctr\$2095

DriveCards-anyone can install in 5minutes!
MINISCRIBE Drive Card 30Mb.....\$ 335
MINISCRIBE 8225 XT 20Mb W/CTRL.....\$ 239
MINISCRIBE 8425F 20MB 40ms 3.5" ...\$249

MITSUBISHI MR535 44(66 RLL) Mb.....\$429

FLOPPY DRIVES

Fujitsu 360K.....\$68 1.2Mb.....\$85
Fujitsu 720k 3.5"....\$88 1.44.....\$ 98

Teac 360K.....\$75 1.2.....\$88
Teac 720k 3.5"....\$88 1.44.....\$ 98

MODEMS & BOARDS

INTEL Connection CoProcessor.....\$ 749

EVEREX EverCom 2400 int MNP3.....\$149
2400E MNP 4.....\$ 179

Intel Connection Co-processor.....\$819

MULTITECH Multi-Modems.....CALL

US ROBOTICS Courier HST to 19,200bps.\$ 629
Sportster 2400 Ext...\$ 178 / 2400 PC\$.158
Sportster 1200 E....\$ 98 / 1200 PC.....\$ 68

AST RAMPAGE+286 -512K.....\$ 509
AST RAMPAGE 2 for XT 256K - Ml. 30.\$ 279
AST, VGA + 256K 16 bit \$339/VGA 8 bit \$ 249
AST Ethernet 16 Bit w/ intelligence.\$369

EVEREX Ultragraphics & 19" Moniterm. CALL
EVEREX Deluxe EGA 640x480 + prt.....\$ 159
EVEREX VGA dual ports.....\$ 249
EVEREX Viewpoint VGA1 6bit/256k..\$279
EVEREX RAM 3000 DLX 0-3Mb eems..\$99
EVEREX Magic I/O AT 1-3 Srl & P.G..\$59
EVEREX RAM 8000/ AT 0-8Mb EEMS \$259

FastData Systems AT Multifunction....\$85
FastData mono/graphics/printer.....\$40
FastData color/graphics/printer.....\$40
FastData EGA w/ Printer port.....\$149
FastData XT Motherboard 10Mhz.....\$75
FastData AT 12Mhz "baby" Ma Bd..\$259
FastData AT 12 Mhz Motherboard..\$289
FastData AT 0-3Mb, 1-2 S, P.....\$125
FastData I/O 1-3 Serial & Parallel\$58
FastData 2nd SERIAL Kit.....\$19

INTELAboveBD/286-Piggy-back512K\$379
INTEL Math Coprocessors.....\$ CALL

NETWORKING

VAR's Let us configure a plug 'N' Play system ready to
load your application software!

4 user NOVELL Network

FastData Systems
80286-12/0,2S & 2P, 14" Mono monitor, 1.2Mb
floppy, 2Mb RAM, 72Mb Drive, 60Mb Tape & Dos
3.3

*American Power Conversion 520W UPS

*Novell ELS NetWare 286 Level 1
Novell Systems Mng'r & User Basics Tutorials
2400 Baud Modem W/PC Anywhere for Support

*4 ArcNet cards, cable, 4-port passive hub

*3 FastData XT's, 10 MHz, 640K, S,P, G, C, &
XTRON 14" T'N'S flat screen Monitor

*Telephone assistance during installation
Your cost\$8,498

PC SOFTWARE & MICE

WE CARRY ALL MAJOR BRAND NAME SOFTWARE TITLES
FOR THE PC/XT/AT AND WE CAN USUALLY SHIP WITHIN
THREE DAYS TO ARRIVE ON YOUR DESK ON THE FOURTH OR
FIFTH DAY!

*Compatibility with PC/XT/AT Clones not
guaranteed. Order Carefully. Opened software not
returnable!

Circle 325 on Reader Service Card (DEALERS: 326)

Microsoft Serial or Buss Mouse.....\$105
Logitech Hi-REZ Mouse.....\$82
Mitsubishi 400 dpi Serial Mouse.....\$89

800-528-3138 Orders Only 602-991-7870 Customer Service



S-100 Div./696 Corp. ♦ 14151 N. 76th St. ♦ Scottsdale, AZ 85260
♦ TELEX 9103806778 SNSCORP ♦ FAX 602-483-0920

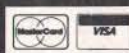

Advertised prices are cash, prepaid, Visa or MasterCard Only! Customers using AMEX, COD's or qualifying for terms, calculate additional charges by dividing above prices by .95. Credit card charged after shipment. Special order items require cash repayment and they are not cancellable / returnable. Shipping first 6 lbs. minimum \$8.00. 7-10 Lbs. \$12.00 *FREE FEDEX up to 10 Lbs. Only! Sales tax. Arizona residents only. Product returns may be subject to a restocking fee or full credit toward a future purchase. All prices and specifications subject to change without notice.

California Digital

17700 Figueroa Street • Carson, California 90248



Color Monitor Better Than EGA \$219

Ideal for CAD/CAM and Desk Top publishing applications. The Roland D/240 color monitor has a resolution of 720 pixels by 400/480 lines on a 31mm dot pitch 12" non-glare screen. VGA specifications in text mode EGA graphic mode.
California Digital has made a special purchase and is able to offer the D/240 EGA/VGA RGB color monitor for only \$219.
Full featured, 132 column, multi-resolution video color adapter card available for only \$159 additional. Comparable card package would retail for \$1095.

Build Your Own Computer \$35 AT Case Only

California Digital has all the components needed to customize your own computer. Buy as much computing power as you need now, and upgrade when the need arises. Here are some examples of components available:

- 10 to 12 MHz Mother board \$89
- 10 to 12 MHz baby AT Motherboard \$29
- Size five drive AT case \$35
- Drive XT case \$25
- 1/2 AT/XT German mtg. Keyboard \$59
- 1 watt AT power supply \$59
- 360K/Byte disk drive \$59
- Monochrome card, printer port \$25
- MegaGraphics (Hercules) printer port \$46
- Color Graphics card \$49
- EGA Color Multi Resolution II \$59
- I/O card, serial & parallel \$35
- I/O PLUS, Ser/Par I, clock, game \$59
- Disk I/O, disk control, clock, game \$59

40 Meg. Tape Back-up \$239



Crash, Power Spikes or just poor disk maintenance... loose data because you didn't back up. The Alloy/40 is an inexpensive to save and restore files in the event that your data has been destroyed. 40 megabyte half height tape back is manufactured by North America's best producer of data retrieval equipment.
Need to purchase a separate tape controller... the Alloy/40 attaches directly to existing floppy disk controller. Supplied software allows your computer to back up any time Day or Night. Come back in the morning and 40 megabytes of placable data has been stored on one Scotch DC/2000 data cassette.
Up entire hard disk, modified files only, or by file name. Loss of data is a catastrophe when you are backed up on an Alloy/40 its not a catastrophe.



One Two Ten		
EC501 1/2 height sgl.side	49	39 35
NDON 101/4 full ht. 96 TPI.	99	89 79
JITSU 5 1/4" half height	65	63 57
TSUBISHI new 501 half ht.	119	109 105
TSUBISHI 504A AT comp.	149	139 135
AC FD55BV half height	89	85 79
AC FD55FV 96 TPI, half ht.	119	109 105
AC FD55GF for IBM AT	109	105 99
ANASONIC 455 Half Height	109	99 89
ANASONIC 475 1.2 Meg./96	119	115 109
Switching power supply		49
al enclosure for 5 1/4" drives		59

3 1/2" DISK DRIVES		
NY MP-53W 720K/Byte	129	125 119
NY MP-73W, 2 Meg.	159	149 call
AC 35FN 720 K/Byte	129	119 115
AC 35HN/30, 2 Meg.	159	149 145
" form factor kit		20

8" DISK DRIVES		
ME 842 double sided	189	179 175
ME 841 single sided	119	109 99
UGART 851R dbl. sided	319	309 299
MEX RFD4000 dbl. sided	189	179 165
IVETTI 851	189	179 165

Saba Scanner \$359

The Saba Scanner inputs a printed page in less than three seconds. OCR software allows your computer to transfer printed pages into ASCII files or directly to spreadsheets and word processing programs.
Archival data, legal briefs... No problem. Simply insert the page into the Saba and in seconds the document is digested into your computer and ready for editing. Also does line drawings that do not require gray tones. Limited quantities available. Original price \$1299; now only \$359.

SCANNERS

SABA SCANNERS		
page scanner with OCR software	1299	359
hand held scanner	799	159
OCR software for hand held		59
DESB SCANNERS		
1000 flat bed page scanner		special pricing
2000 edge feed scanner	935	719
MICROTECHMSF300G 256 gray scales	2195	1759
DFI HandiScan 300 with Halo		359 239
PRINCEON GRAPHICS LS-300		1095 799
PANASONIC RS505 Image page scanner	1499	999
RS506 Page scanner	1899	1259
DATACOPI		
730 flat bed scanner	1800	1159
640 flat bed scanner	6800	4159
SPECIAL PRODUCTS		
XEROX Ventura PC Publisher	895	499
ALDUS PageMaker PC	795	459
COMPLETE PC FaxCard 4800	399	279
QUADRAM JT FaxCard 4800	395	259

MONITORS

MICROWITEC 945CN, 20" 1freq. 31.5KHz. 1300x900	1895	659
1019, 20" autosync 31 dot 1024x580	2395	1687
MITSUBISHI AUM 1361 13" diamond scan 800x600	889	519
HJ 6905ATK 20" multiscan	3650	2297
HITACHI 4119 19" 1024x768, 31 dot, 48 KHz.	2490	2195
4115 15" 1280x1024, 65 KHz.	1990	1159
CONRAC 7250, 19" multi. 1024x1024	2995	1999
SONY MONITORS		
1903, 13" 37 dot, multiscan	825	595
1954, 19" 48 KHz.	4195	2993
MAGNIFOX SCM082, 14" 640x480	649	459
NEC MultiSync II, 14" 800x560	949	597



Amstrad 40 Megabyte Hard Disk Kit \$695

Forty megabyte internal hard disk drive, controller and cables all for only \$397. The kit includes the a 40 milisecond Miniscribe 3650 drive and a half slot Western Digital controller.

Two 720K/byte 3 1/2" drives
640 K/byte DRAM memory
2400 baud internal modem
Supertwist LCD display
16 color RGB/CGA output
Full feature 101 keyboard

Take it to school, court, news events or anywhere that you require "computing power" on the go. Built in 2400 bps Hayes compatible modem allows you to transfer data files with your home office or any World wide data base.

A little to large to be called a laptop but the Amstrad 640 is a true battery operated IBM compatible portable. (17% by 9" footprint). Includes: full featured AT style 101 keyboard • DOS 3.3 • serial port • printer • port2400 bps. modem • carrying case • power adapter and cigarette lighter power cord.

Hard to believe... but we found a stash of brand new fully factory assembled Zenith/Heath Model H/89s. These computers feature 64K/byte of memory, the Zilog Z-80 CPU and operate under CP/M. The unit incorporates a 12 inch green screen, three serial ports and one 5 1/4" disk drive. Zenith's original price was \$1895. We have still 97 units available for sale, while supplies last we are offering the H/89 at only \$179. CP/M operation system available \$24.95

Hitachi Plotter \$595

The Hitachi 672/XD is a four color 11 by 17 (B size) plotter with superior accuracy and repeatability (.3mm). The 672 accepts HPGL 7475 commands and is both serial and Centronics compatible. The 672 plots at a fast eight inches per second in axial direction and eleven inches at an angle of 45 degrees. The plotter also features a self contained digitizing function that allows data to be entered into your computer from printed graphs and blue prints.

PLOTTERS

HOUSTON INSTRUMENTS		
DMP 41 single pen, 3 ips, C&D	2995	2295
DMP 52 single pen, 16 ips, C&D	3295	2495
DMP 56C size A-E, 16 ips	5695	3095
DMP61 single pen, 32 ips, A-D	4295	3095
PC685A 4 pen, size "B" 3 ips	799	595
CALCOMP PLOTTERS		
1023 Artisan A-D, 8 pen, 30 ips	4895	3795
1043GT size A-E, 8 pen, 24 ips	7995	5495
HEWLETT PACKARD		
7475A 6 pen size "B"	1895	1495
7550A 8 pen size "B" 32 ips	3900	2995
7550A 8 pen size A-E, 24 ips	9990	7995
HITACHI PLOTTERS		
672/XD 4 pen, size "B"	895	595
675 size "A-D" 8 pen	5800	3995
FUJITSU Imagegraph, 6 pen, 11x 32	1295	895
IOLINE PLOTTERS		
LP3700 size E, 10 ips	4195	3195
LP3700MP 8 pen size "E" 10 ips	4695	3495
ROLAND PLOTTERS		
DX980 flatbed size "B" 8 pen, 9 ips	1795	695
DPX2000 size "C" 8 pen with stand	2995	2195
DPX3300size "D" 8 pen with stand	4995	3495
ENTER COMPUTER		
SP600 size "B" 6 pen	995	659
SP1000 single pen size A-D	3995	2795
SP1800 8 pen, A-D, 32 ips	4695	3359
JDL 850, size "C" one meg. memory	3845	2789
VERSATEC 8524 Electrostatic	16,900	13789
NUMONICS		
5480 size "A-D"	2495	1859
5680 size "A-E" 8 pen	7495	5759
AUTODESK		
AutoCad version 10	2995	2195
AutoSketch Std & Enhanced 2.0	99	79
VERSACAD Designer	2995	1995
GENERIC CAD level 1	49	35
AMERICAN SM. BUS'N. Design Cad	299	179

CAD SOFTWARE

As Low As \$279 Digitizers

California Digital offers over 50 different digitizers. We have two which appear to offer the best values. Both are 12" by 12", one thousand line per inch resolution, are supplied with four button cursor. The first digitizer is the Genius Tablet priced at only \$279. This is a new product from KYE of Taiwan. The other unit, pictured above, is the Puma Pro manufactured by Hitachi and warranted for ten years. The Puma boast a .0015" repeatability. Only \$359 and includes a stylus.

DIGITIZERS

HDC 1212 Puma 12x12"	595	359
HDC 1515 15x15"	969	659
Tiger 1111C, 12x12 stylus extra	727	487
HGC 3648, 36x48"		5357
SUMMAGRAPHS		
Summa 1201 plus 12x12"	599	379
TB 3648, 36x48"	4748	3729
KYE Genius Tablet w/4 but. mouse	599	279
CALCOMP		
25180, 12x18"	1275	999
91400, 36x48"	4118	3389
GITCO DIGITIZERS		
2436L, 24x36"	2795	1999
DP 1111A, 11x11"	599	459
KURTA DIGITIZERS		
IS/ONE w/mouse & stylus	645	399
IS/THREE, 36x48"	4895	3759
HOUSTON INSTRUMENTS		
TG1011 11x11" stylus & power add.	685	519
HPad 9012, 12x12 complete kit	495	399
HPad 9018, 12x18 complete kit	795	599

PRINTERS

HEWLETT PACKARD Laser Printer II, 300x300	2595	1659
Laser Printer II/D double sided	3995	
QMS PS/810 2 Meg., 35 fonts, Post/S.	5495	3879
APPLE Laser Writer NT	4450	3659
NEC890 Postscript 3 meg	4950	3095
TEXAS INSTRUMENTS		
2115 Postscript 15 pgs.	7995	5785
2108 Postscript ser. par1, & Apple	5995	4295
DATAPRODUCTS		
LZR 1260 Postscript 12 pgs.	7995	5895
LZR 2500, 11" by 17" 25 pgs./min.	13,500	9897
MANNESMANN TALLY 905, HP/II	1995	1295
FUJITSU FX7100D w/ two paper bins	2550	1359

Amstrad 40 Megabyte Hard Disk Kit \$397

Forty megabyte internal hard disk drive, controller and cables all for only \$397. The kit includes the a 40 milisecond Miniscribe 3650 drive and a half slot Western Digital controller.



Five Inch Winchester Disk Drives		
Price does not include controller. each two-		
SEAGATE 225 20 Meg. 1/2 Ht.	239	229
SEAGATE 238 30 Meg. RLL	259	249
SEAGATE 251/1 51 M. 28ms.	455	445
SEAGATE 4096 96 M. 35ms.	559	539
MINISCRIBE 8425 25 M 65ms	239	227
MINISCRIBE 3650 50M 61 ms.	319	309
MINISCRIBE 6085 90 meg.	459	435
MINISCRIBE 3053 25 ms. 1/2 ht.	359	339
FUJITSU 2242 55 M. 35ms.	1299	1229
FUJITSU 2243 86 M. 35ms.	1695	1619
RODIME RD-204E 53 Meg.	895	859
MAXTOR XT1140 140 Meg.	1495	1450
MAXTOR XT2190 192 Meg.	1919	1875
TOSHIBA MK56 70 M. 30ms.	1289	1229
CONTROL DATA WREN "W"	call	

Winchester Controllers for IBM/PC		
XBEC 1220 with floppy controller	159	159
DTC 5150CX		119
OMTI 5527 RLL controller		99
ADAPTEC 2070 RLL controller		99
ADAPTEC 2372A 1/1 interleaf		159
WESTERN DIGITAL WD/1002WX2		89
WESTERN DIGITAL 1003WAH or WA2		139
WESTERN DIGITAL 1007/WA2 ESDI		239
SCSI/SASI Winchester Controllers		
XBEC 1410A 5 1/4" foot print	239	
WESTERN DIGITAL 1002-05E 5 1/4"	229	
OMTI 20L		89
Winchester Accessories		
Dual floppy enc. and powersupply		59
Winchester enclosure and supply		139
Switching power supply		49

master charge
VISA
8:00 AM to 5:00 PM Pacific Time

Every year since 1973, customers from virtually every nation in the free World have chosen California Digital for their data processing requirements. If its computer, California Digital has it... complete minisystem or just one microchip. California Digital offers over 10,000 unique computer products. Regardless of how specialized your data processing requirements... California Digital is your one stop shopping solution.

TECHNICAL & CALIFORNIA
(213) 217-0500
TOLL FREE ORDER LINE
(800) 421-5041
Telefax • (213) 217-1951

EZ-ROUTE VERSION II

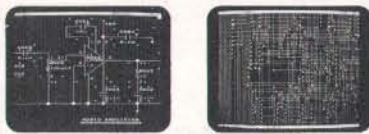

SCHEMATIC TO PCLAYOUT \$500 INCLUDES AUTO ROUTER

EZ-ROUTE Version II from AMS for IBM PC, PS/2 and Compatibles is an integrated CAE System which supports 256 layers, trace width from 0.001 inch to 0.255 inch, flexible grid, SMD components and outputs on Penplotters as well as Photo plotters and printers.

Schematic Capture \$100, PCB Layout \$250, Auto Router \$250.

FREE EVALUATION PACKAGE

30 DAYS MONEY BACK GUARANTEE
1-800-972-3733 or (305) 975-9515

ADVANCED MICROCOMPUTER SYSTEMS, INC.
1321 N.W. 65 Place - Ft. Lauderdale, FL 33309

Circle 20 on Reader Service Card

a complete 80386
system for only

\$1995

- ☞ 1 meg ram
- ☞ 40 meg. hard drive
- ☞ TTL mono. monitor
- ☞ Parallel & Serial Ports
- ☞ Expand to 16 meg.
- ☞ 1 year warranty
- ☞ 30 day moneyback

Call for other systems and configurations at similar savings.

Scioto Computers
1-800-283-8616

Circle 253 on Reader Service Card

Dynamic
Electronics

SIMMS

CALL FOR PRICES

INTEL	DRAMS	SIMMS
8087	64K	256 X 8
80287	256K	X9
80387	4464	1 Meg X 8
80387SX	1 Meg	1 Meg X 9
80C287A		

Phone 714-855-0411
Fax: 714-855-8504

23522 COMMERCE CENTER DR. #L
LAGUNA HILLS, CA 92653, USA

Circle 91 on Reader Service Card

REAL WORLD I/O For PC/XT/ATs

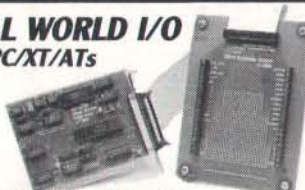

DG24 • 24 line digital I/O; 10 MHz 8255. \$95

AD500 • 8 channel 12-bit (plus sign) integrating A/D; prog. gains of 1, 10 & 100; 7 digital I/O lines. \$239

AD100 • Single channel version of AD500; 10 digital I/O lines. Same programmable gains. 700 meg input Z. \$149

AD1000 • 8 channel 12-bit A/D; 25 uS; sample & hold; 3.5 MHz timer/counters; 24 digital I/O lines. \$295

ADA300 • 8 channel 8-bit 25 uS A/D; single D/A sample & hold; 24 digital I/O lines. \$239

AD200 • 4 channel 12-bit 125 uS A/D; 3.5 MHz timer/counters; 24 digital I/O lines. \$239

DA600 • Fast settling dual bipolar D/A. \$179

PD200 • Prototype board w/ address decoder; manual \$99

All boards include BASIC, Pascal, C, and Fortb drivers.

30 day return; 1 year warranty. Call for "Real World

Interfacing" application notes.

Real Time Devices, Inc.

P.O. Box 906 State College, PA 16804
(814) 234-8087

Circle 241 on Reader Service Card

E/EPROM & MICRO PROGRAMMER

\$895



- EP-1140 includes: software, cable, user's manual, 2 free software update coupons, toll-free technical support, one-year warranty & a unconditional 30-day money back guarantee
- Programs 24-, 28-, 32- & 40-pin E/EPROMs
- Supports 874X & 875X series microcontrollers
- Connects to a standard parallel port
- 32-pin model, EP-1132, available for \$695

The Engineer's Programmer™

CALL TODAY 800-225-2102

BP MICROSYSTEMS

10681 Haddington, #190, Houston, TX 77043
713/461-9430 FAX 713/461-7413

Circle 50 on Reader Service Card

IMAGING CARDS

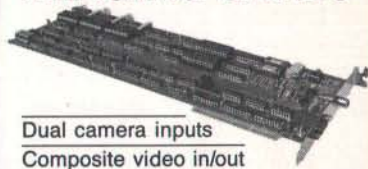

Dual camera inputs

Composite video in/out

256 x 240 resolution

Digitize/display at frame speed

16 Meg. color palette out (DV-02)

External trigger input option

PC/XT/AT compatible

Complete with software & library

DV-02 8-bit 256 gray levels. \$849

DV-03 6-bit 64 gray levels. \$549

VISA/MC Demo disk available

Control Vision

PO Box 596 Pittsburg KS 66762
800/292-1160 316/231-6647

Circle 73 on Reader Service Card

NEW **DOSTAR™** NEW

TAR FOR MSDOS WITH UNIX/XENIX COMPATIBILITY

Read, write 16 different Unix formats including
Altos, AT&T, IBM, NCR, Tandy & others

Multiple disk types — 3 1/2", 5 1/4" and 8"

Fully compatible with Unix tar

— backup under MSDOS, restore onto Unix
— backup Unix files, restore onto MSDOS

Menu-driven, using windows.

function keys, on-line help

Only \$295.00

Bringing Unix & DOS together

New Generation Systems, Inc.

3609-B Chain Bridge Rd., Fairfax, VA 22030

Tel: (703) 691-0779

Fax: (703) 691-0397

In Canada please call:

New Generation Systems (Canada)

1110 Kamato Rd., Units 18-19, Mississauga, Ont. L4W 2P3

Tel: (416) 238-1047

Fax: (416) 238-1039

Altos, AT&T, DOSTAR, IBM, MSDOS, NCR, Tandy.

Unix, Xenix, are trademarks of their respective companies.

Circle 196 on Reader Service Card

RS-232 FOR PS/2



MODELS 50, 60, 80

- DCE/DTE Selectable
- Transfers to 19.2 K baud
- Address Selectable
- Interrupt Selectable

1-800-553-1170

QUA TECH
INCORPORATED

478 E. Exchange St., Akron, OH 44304
TEL: (216) 434-3154 FAX: (216) 434-1409
TLX: 5101012726

Circle 223 on Reader Service Card

NEW

PARALLEL PORT FOR PS/2



MODELS 50, 60, 80

- LPT1, LPT2, LPT3
- Optional Serial Port
- OEM Pricing Available

1-800-553-1170

QUA TECH
INCORPORATED

478 E. Exchange St., Akron, OH 44304
TEL: (216) 434-3154 FAX: (216) 434-1409
TLX: 5101012726

Circle 224 on Reader Service Card

ACP Top 10 Mail Order

Call ACP toll-free 1-800-FONE-ACP • 1-800-366-3227

Selected



LOW COST COMPATIBLE BOARDS

ACP Advanced Cards/IBM	
ACP Mono/Color w/print port	49.
ACP Mono w/color emulation	59.
ACP SuperEGA/480	169.
ACP VGA/256	199.
ACP SuperVGA/1024 x 768	249.
DFI Multi I/O, 2.5 p.g. c/k/XT	139.
ACP Six-Pak compatible/XT, OK	89.
ACP 286 Accelerator/XT	249.
ACP Multi I/O w/floppy contr./XT	59.
ACP Dual Floppy controller/XT	29.
ACP Serial I/O card/XT	29.
ACP Parallel I/O card/XT&AT	29.
ACP Serial I/O card/AT	39.
ACP Game adapter port/XT&AT	29.
ACPEPRM programmer/4 ports/149.	
ACP 1.44Mb Floppy controller	79.
ACP AT Prototype card	79.
DFI 3.0Mb Multi I/O/10MHz/AT	129.
DFI 4.0Mb Megalith EEMS 4.0/AT	199.
DFI SuperMulti I/O/W/10MHz/AT	69.
DFI Megabit 2Mb uses 1Mb DRAM	99.
DFI Net30 Ethernet/Novell approved	169.
DFI Rambank 2/PS2 50,60	149.

INPUT DEVICES+MICE

Advanced PC Keyboards	
5160 84key XT/AT/switchable	59.
5161 101key XT/AT/switchable	79.
KEYTRONICS	
KB5151 Deluxe IBM w/99 keys	139.
KB101 101 key/AT	110.
MB101 101 key/XT, AT, PS2	79.
LOGITECH	
Bus Mouse PC/XT/AT	79.
Serial Mouse PC/XT/AT	75.
Serial Mouse PS/2	75.
MICROSOFT	
Bus Mouse w/PC Paintbrush	99.
Serial Mouse w/PC Paintbrush	99.
Serial PS/2 w/PC Paintbrush	99.
MSC Technologies	
PC Mouse serial PC/XT/AT	98.
PS/2 Mouse serial	98.
PC Mouse bus PC/XT/AT	98.

The Complete PC Half Page Scanner



Scans a 4" width with 200dpi resolution, includes the powerful SmartScan editing software and it's now available from ACP for under \$200.

PLUS Development

Plus20 Hardcard, 20Mb, 49ms	529.
Plus40 Hardcard, 40Mb, 39ms	669.
Passport 20	429.

PANASONIC

1080/1190	189/250.
1092/1592	325/405.
1524/1124	549/349.
Panasonic 4450 Laser	1419.

STAR

NX 1000, 80 col, 9 pin	199.
NX 1000, Rainbow, 80 col, 9 pin	269.
NX 2400, 80 col, 24 pin	299.

TOSHIBA

P321SL, 24pin, 216cps	468.
P341SL, 24pin, 216cps	569.
P351SL (color add \$179)	879.
Expresswriter 301/31	319/399.
Pagerlaser, 12	2499.

MODEMS+COMMUNICATIONS

Advanced MODEMS	
1200baud w/software(int)	49.
1200baud w/software(ext)	87.
2400baud w/software(int)	96.
2400baud w/software(ext)	139.
COMPLETE PC	
CFAX 4800 PC fax board	288.
CFAX 9600 PC fax board	449.
Hand Scan 400	178.
200,300,400dpi resolution	178.
HalfPage Scanner	188.
FullPage Scanner	548.
Complete Answering Machine	247.
HAYES	
1200/2400 (internal)	269/378.
Smartmodem 2400 (external)	423.
INTEL	
Connection Coprocessor	699.
w/sw/int	219.
optional 2400baud modem	219.
2400B Modem2	319.
for 50z,60,70,8	319.
2400B Classic Modem2	269.
for XT/AT	269.
MIGENT	
Pocket MODEM 1200	salet 79.
PRactical PERIPHERALS	
1200/2400 (internal)	64/149.
1200/2400 (external)	79/178.
PROTHEUS	
2400G (external)	188.
1200B/2400B (internal)	89/149.
MONITORS+TERMINALS	
AMDEK	
310A 12" amber TTL	Reduced-881
410A/1280	149/699.
IBM MONITORS	
8503/8512	199/499.
8513/8514	549/1195.
NEC	
Multisync II/Multisync 3D	595/887.
Multisync XL 201(1024x768)	2099.
Monograph sys (1024x1024)	1499.
SAMSUNG-IMTEC	
1256A 12" amber TTL mono	88.
1457A14" amber flat screen	128.
1457W14" white flat screen	135.
1464K 14" CGA/RGB Color	248.
1453 14" EGA Color	375.
14530 14" VGA Color	375.
1455 14" Multisync Color	439.
5671 15" Fullpage white w/card	699.
WYSE	
WY30/WY50 14" terminal	329/399.
WY60/WY150	419/419.

COMPUTERS+CLONES

Advanced 386 Clones save\$	
Advanced386/16 bare bones	995.
Advanced386/16 base system	1795.
Advanced 286 Clones save\$	
Advanced286/12 bare bones	389.
Advanced286/12 base system	849.
Advanced286/16 base system	1049.
Advanced XT Clones save\$	
Advanced XT bare bones	179.
Advanced XT base system	588.
call for options & details	
AST Research	
Premium286 Model 80	1495.
Premium BRAVO	call.
Premium386 Model 340	3299.
call for all AST models	
HYUNDAI	
Hyundai286/Turbo16TE	call.
NEC	
Prospeed 286/Prospect 386	call.
UltraLite	call.
SHARP	
PC7221 Portable286, 20Mb	1499.
TOSHIBA LAPTOPS	
T1000 Laptop	749.
T1200P/1200HB	1577/2395.
T1600/3100e	3295/2877.
T3200 286 full keybd, 40Mb	3495.
T5100/5200	4575/5988.
WESTERN DIGITAL	
StarLanPLUS	877.
kit w/sw(3 users)	877.
(network for less than \$300/node)	
ViaNet LAN software	85.
Starhub	329.
Ethercard PLUS	249.
Ethercard PLUS TP	319.
(twisted pairs)	
Ethercard PLUS/A	319.
(microchannel)	
PLOTTERS	
HOUSTON INSTRUMENTS	
DMP52/52MP	call.
SCANANG	call.
DMP56A/6162	call.
CALCOMP	
1023	3835. 1042
1042	6475. 1044
7535	9910.
KURTA	
1212 IS1	349. 12x17
36x48	2888. 4 bttm cursr.
74.	
SUMMASKETCH	
12x12	375. 12x18
629.	
POLAROID	
5 1/4" DSSD 7	39.
5 1/4" DSHD 13	3-1/2" DSSD 15.
3 1/2" DSSDDH	39.
3M	
5 1/4" DSSD 8	39.
5 1/4" DSHD 14	3 1/2" DSSD 15.
3 1/2" DSSDDH	39.
BULK	
5 1/4" DSSD box of 100	35.
5 1/4" DSHD box of 100	59.
Advanced PRINTER BUFFERS	
ACP 256k parallel buffer	198.

Advanced SWITCH BOXES

ACP 2-position AB, 3636	27.
ACP 2-position AB, 2525	24.
ACP parallel/serial converter	69.
ACP serial/parallel converter	69.
Buffalo SX PC share (up to 7)	499.
Logical Connection 256K	439.
INTELLICOM	
Longlink-Parallel	199.
TRIPLITE	
Isobar4 surge supp w/4 outlets	53.
Isobar8 surge supp w/8 outlets	69.
Line Conditioner w/4 outlets	149.
Backup Power Supply, 450w	299.
Backup Power supply, 750w	499.
Backup Power Supply, 1200w	649.
Backup Power Supply, 2000w	1199.
SOFTWARE	
ALDUS	
Pagemaker/IBM	478.
ALPHA SOFTWARE	
Alpha/tree 1.0	149.
ASHTON TATE	
dBase III plus	249.
dBase IV	445.
Multimate Advantage II 1.0	149.
BORLAND	
FRAMEWORK III	429.
Quattro	164.
Paradox	469.
COMPUTER ASSOCIATES	
nep	
Supercalc 5	299.
Superproject	call.
DAC SOFTWARE-nep	
DAC Easy Light v1.0	41.
DAC Easy Accounting	58.
FOX SOFTWARE	
Foxbase+ r	194.
LOTUS	
Graphwriter II	call.
Lotus 123	call.
Manuscript	call.
HOUSTON INSTRUMENTS	
DMP52/52MP	call.
SCANANG	call.
DMP56A/6162	call.
CALCOMP	
1023	3835. 1042
1042	6475. 1044
7535	9910.
MICROFORM R-BASE DOS	559.
MICROSOFT-nep	
Windows 286/386	64/124.
Word v4.0	209.
Excel	224.
NORTON-nep	
Utilities	51.
Commander	46.
Advanced Utilities	75.
SOFTWARE PUBLISHING	
First Choice/First Publisher	91/74.
HARVARD GRAPHICS	272.
SYMANTEC Q & A	212.
TRAVELING SOFTWARE	
Laplink Plus	79.
XEROX	
Ventura	499.
WORDPERFECT-nep	
WordPerfect v5.0	224.
WordPerfect Library	65.

MOTHERBOARDS

XT Turbo w/BIOS/8MHz	89.
XT Turbo w/BIOS/10MHz	99.
AT 286 w/BIOS/12MHz/XT size	279.
AT 286 w/BIOS/16MHz	449.
AT 386 w/BIOS/20MHz	799.

CHIPS-SIMM MODULES

256K 120ns	7.
256K 100ns	21.
1Mb 80ns	23.
1Mb 70ns	25.
256x9 120ns 79	256x9 80ns 99.
256x9 100ns 89	64Kx1
1Mbx9 SIMM Module 120ns	225.
1Mbx9 SIMM Module 100ns	245.
1Mbx9 SIMM Module 80ns	265.

SEAGATE

20Mb ST225(65ms) HH MFM	239.
30Mb ST238R(65ms) RLL HH	269.
40Mb ST251(40ms) MFM HH	395.
40Mb ST251-1(28ms) RLL HH	438.
60Mb ST277R(40ms) RLL HH	469.
40Mb ST4053(28ms) MFM FH	519.
80Mb ST4096(28ms) MFM FH	669.
20Mb ST125.3.5(40ms) MFM	288.
30Mb ST138.3.5(40ms) MFM	369.

WESTERN DIGITAL

Filecard PS30 PS2 model 30	398.
Filecard 30	349.
1006V-MM1 16bit MFM 1:1	149.
1003V-SR1 RLL 3:1	157.
1006V-MM2	155.
Floppy/Hard MFM 1:1	199.
1002-27X 8bit RLL/XT	98.
WX1 Controller MFM/XT	88.
WD286-WDM20	call.
AT/286 motherbd	call.
TAPE BACKUP/VIDEO	
ALPHAMICRO	
VCR Videotrax	
tape backup card	269.
VCR Videotrax	
tape backup PS2	349.
IOMEGA	
Bernoulli 8120X 51/4" internal	983.
Bernoulli 8220X 51/4" extl	1599.
Bernoulli 20-20 8" ext	1649.
Tri-pak 20Mb cartridge, 51/4"	189.
Tri-pak 20Mb cartridge, 8"	239.
PC50 Adapter card	149.
PC3B/50 Adapter card	299.
IRWIN	
2020 20Mb backup(internal)	325.
2040 20Mb backup(internal)	425.
445A 40Mb backup(external)	499.
TALLGRASS Technologies	
104Di 40Mb backup(internal)	338.
1040e 40Mb backup(external)	549.
PRINTERS+LASERS	
CITIZEN	
120D	149. 180D
189.	
MSP40	299. MSP55
578.	
DICONICS/KODAK	
150PS/300P	call/499.
EPSON	
DPX500	call. L0500
295.	
LX800	189. L0850
525.	
FX850	349. LQ1050
735.	
FX1050	449. LQ950
595.	
EX800	399. LQ2550
925.	
ACP-your full line Epson dealer	
HEWLETT PACKARD fonts/etc.	
25 in 1 cartridge	345.
(compatible)	
Spreadsheet cartridge	165.
(compatible)	
Z cartridge(compatible)	119.
Jetware 1Mb upgrade memory	call.
IBM PRINTERS	
Printer II, 240cps	419.
Printer X24, 240cps 24pin	599.
Printer XL24, 240cps 24pin	799.
NEC	
P2200, 24pin(360x360dpi)	379.
PS200/5300	569/719.
LC890 Silentwriter	3395.
300 DPI Laser printer	3395.
OKIDATA	
ML390/391	489/659.
ML393/393C	995/1095.

I/O+GRAPHICS+PC BOARDS

AST Research	
Xtreme/286, 512K, 10MHz	575.
Advantage Premium/512K	398.
Advantage 286/512K	374.
Advantage 2/512K, PS2	408.
Rampage2/512K, EEMS, PS/2	378.
Rampage 286/512K, EEMS, 2Mb	388.
Rampage Plus/286/512K, EMS	498.
AST Sixpakplus, 64K	118.
AST Hotshot 286 accelerator	324.

ACP has full line of CHIPS!

COPROCESSOR+CHIPS-INTEL	
8087	97. 80287-8
225.	
8087-1	196. 80287-10
266.	
8087-2	142. 80387-16
395.	
80287-6	155.
80387-20	475.
Wietek	call 80387-SX
395.	

Laptops for less...

Why ACP sells more TOSHIBA

- Pricing
- Service
- Availability

ACP won't be undersold for Toshiba laptops & printers.

PC MAGAZINE

Editor's Choice

ATI Technologies

EGA Wonder 800	235.
VIP VGA	299.
VGA Wonder (1024x768) 256K	329.
ATI240etc	
int. Modem w/MNP-5	199.

FLOPPY DISK DRIVES

SONY	
31/2" Micro Floppy 1.44Mb	129.
TEAC	
585V 360K Floppy/PC/XT/AT	77.
TOSHIBA AMERICA	
FDD4403 31/2" 720K w/kit	86.
31/2" 1.44Mb w/kit	109.
ND04D 360K Floppy black bezel	84.
ND04E-G 360K Floppy beige	84.
ND08DE-G 1.2Mb AT beige	109.

GENOA

Super EGA/Hi-Res Plus	229.
Super VGA/Hi-Res	389.
Super VGA/256K	339.
Superspectrum mono CGA/HGA	149.

Advanced DriveCard

ACP 20Mb DriveCard	288.
ACP 30Mb DriveCard	359.

Paradise

Autoswitch EGA 480 /Hi-Res	199.
VGA Plus/800X600	274.
VGA Plus 16/800X600	298.
VGA Professional/800X600	459.

External Floppy Drives

YOU'LL
GO...APE!

**FEDERAL EXPRESS
SECOND DAY AIR!**
Ask Us About Special
Low, Low Rates!!!

Panasonic
Office Automation **OA**

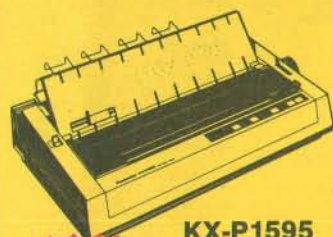

KX-P1595
\$439

**2 YEAR
WARRANTY**

- KX-P1180 \$179
- KX-P1191 \$249
- KX-P1592 \$429
- KX-P1595 \$439
- KX-P1524 \$539
- KX-P4450 \$1395
- KX-P1124 \$329

FX-RS505
Image Scanner



With Interface
and Cable
(List \$1499)

Fax Partner
FX-BM89
Fax
Board
\$599
(List \$995)



Also Available
FX-RS506

- Faster
 - Higher Resolution (List \$1899)
- \$1195**

SPECIAL OFFER



Laser Partner™
KX-P4450

\$1395 (List \$2595)

- Two 250-sheet paper cassettes
- 300 dot-per-inch resolution
- Five popular printer emulations
- Standard parallel and RS-232 serial interfaces
- Convenient front panel controls
- 512K RAM standard

Panasonic - Panafax
**THE LITTLE
BIG FAX.**



PANAFAX UF-250

IN STOCK NOW FOR SAVINGS!!

- UF-150 \$1075
- UF-250 \$1395
- UF-260 \$1850

H-P COMPATIBLE FONTS
AND
MEMORY

- **NEW! NEW! Plotter In A Font** \$249
- **The All In One**
25 In 1 Font \$268
- **For Lotus, Slik**
Spreadsheet Font Special \$110
- **Upgradable Memory Boards**
1MB \$274
2MB \$544
4MB \$944

PACIFIC DATA PRODUCTS



Orders Only
1-800-272-9276

FAX Orders
(802) 334-6892

Inquiries & Technical Support
(508) 393-7220 (802) 334-5800

HOURS: 9AM-8PM MON-FRI EASTERN STANDARD TIME
10AM-4PM SAT
We Accept At No Additional Charge



APPLIED • PROGRESSIVE • ELECTRONICS • INC.

203 Southwest Cutoff Route 20, Northboro, MA 01532
FAX (508) 393-3124 • Phone (508) 393-7220

American Express Also Accepted

Expires 6/30/89

★ Order by FAX using a Credit Card and receive Free Freight!!
(UPS GROUND)

ALL ITEMS OFFERED WHILE STOCK LASTS. We ship anywhere in the continental United States via UPS. Prices are subject to change without notice. We accept VISA, MasterCard, personal, company checks and money orders subject to prior approval.

All returns must have prior authorization from customer service department within 7 days of receipt. All returns must be in like-new condition and in original packaging. Incomplete returns will not be accepted for return. Returns for merchandise credit only.

Defective products will be repaired or replaced at APE's discretion. We do not guarantee originality. Not responsible for typographical or printing errors. ALL PRICES QUOTED ARE FOR PREPAID C.O.D., OR CREDIT CARD ORDERS ONLY.

YOU'LL

GO...APE!

BE SURE TO ASK US ABOUT



**HEWLETT
PACKARD
ACCESSORIES**

EPSON®



LX-800
Dot-Matrix Printer

- Full-featured, 80-column printer
- 180 CPS draft mode; 30 CPS NLQ
- Automatic single sheet loading
- SelectType front control panel
- Compatible with most computers
- One year limited warranty

NOW ONLY \$179

The LQ-500 combines the advantages of 24 pin Letter Quality printing with the benefits of affordable performance. With Epson's exclusive SelectType front control panel, the LQ-500 gives you push-button control of an array of impressive features. The LQ-500 also comes equipped with a pull tractor and friction feed with single-sheet auto load, which allow you to utilize a wide variety of paper.



LQ-500

NOW ONLY \$289

The LQ-850 combines SmartPark™ paper handling with 24-pin Letter Quality printing excellence. With SmartPark, you can quickly switch paper types without removing hardware or paper. And the LQ-850's SelectType front control panel gives you push-button control of an array of impressive features. For word processing and general office correspondence, this narrow-carriage printer is ideal.

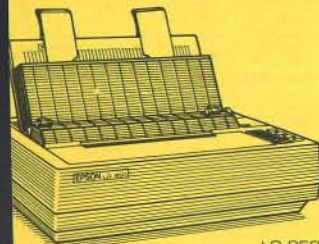

LQ-850

CALL \$\$\$\$\$\$

Dramatic Savings On All Other Epson Printers

EX 800, FX 850 & 1050, LQ 850, 1050 & 2550

ALL EPSON RIBBONS 3 for 2

Ask About Great Printing On All Epson Products

ALL PRODUCTS IN STOCK

SHARP®

**FROM SHARP MINDS
COME SHARP PRODUCTS™**

- 10 MHz High Speed 80286 CPU (6/8 MHz switchable)
- Illuminated Supertwist Crystal Display with 4 gray scale levels
- Dual high density floppies (PC-7202) or single floppy and 20MB hard disk drive (PC-7221)
- 120 key detachable keyboard with separate numeric and cursor keypads
- 640 KB of RAM, expandable to 1.6 MB on the system board
- One internal expansion slot for full-size PC and AT compatible expansion cards
- Parallel, serial, and color/monochrome CRT ports
- One internal expansion slot for full-size PC and AT compatible expansion cards
- Optional internal modem card and expansion unit with four card slots

MODEL PC-7200 SERIES
The power of a desk-top AT in a compact portable unit



PC-7200

PC-7221 \$1495 PC-7241 \$2195

**Battery Powered
LAPTOPS from SHARP®**

- High contrast, illuminated supertwist display
- 20 MB hard disk drive and single 3.5 inch floppy drive
- High speed processor (7.16 MHz)
- 640K RAM
- Full-sized keyboard with 10 key numeric pad
- Software compatible with IBM PC
- Optional 300/1200 baud modem, CRT adapter, 1 MB EMS card, 768K EPROM card
- Also available with dual 3.5 inch floppy disk drives (Model PC-4502)



PC-4521

PC-4502 \$895
PC-4502M \$1095
PC-4521 \$1695
PC 4521M \$1895



PC-4600 SERIES.....CALL



APPLIED • PROGRESSIVE • ELECTRONICS • INC.

Southwest Cutoff Route 20, Northboro, MA 01532
(508) 393-3124 • Phone (508) 393-7220

**Orders Only
1-800-272-9276**

HOURS: 9AM-8PM MON-FRI EASTERN STANDARD TIME
10AM-4PM SAT

We Accept At No Additional Charge



American Express Also Accepted

Expires 6/30/89

**FAX Orders
(802) 334-6892**

**Inquiries & Technical Support
(508) 393-7220 (802) 334-5801**

ALL ITEMS OFFERED WHILE STOCK LASTS
Ordering information: We ship anywhere in the continental United States via UPS. Prices are subject to change without notice. We accept VISA, MasterCard, personal, company checks and money orders subject to prior approval.

All returns must have prior authorization from our customer service department within 7 days of receipt. All returns must be in like-new condition, complete and in original packaging. Incomplete merchandise will not be accepted for return. All returns for merchandise credit only.

Defective products will be repaired or replaced at APE's discretion. We do not guarantee compatibility. Not responsible for typographical errors. ALL PRICES QUOTED ARE FOR PREPAY, C.O.D., OR CREDIT CARD ORDERS ONLY.

**Order by FAX using a Credit Card and receive Free Freight!!
(UPS GROUND)**

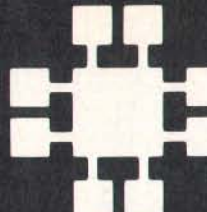

JDR Microdevices

MMC
MICROCOMPUTER
MARKETING COUNCIL
of the Direct Marketing Association, Inc.

• 30 DAY MONEY BACK GUARANTEE • 1 YEAR WARRANTY ON ALL PRODUCTS • TOLL-FREE TECHNICAL SUPPORT
• COMPLETE CUSTOMER SATISFACTION • SUPERIOR SERVICE • FRIENDLY, KNOWLEDGEABLE SALES STAFF

EPROMS

PART	SIZE	SPEED	Vpp	PRICE
2708	1024x8	450ns	25V	4.95
2716	2048x8	450ns	25V	3.49
2716-1	2048x8	350ns	25V	3.95
2732	4096x8	450ns	25V	3.95
2732A	4096x8	250ns	21V	3.95
27C64	8192x8	250ns	12.5V	4.95
2764	8192x8	450ns	12.5V	3.49
2764-250	8192x8	250ns	12.5V	3.69
2764-200	8192x8	200ns	12.5V	4.25
27128	16384x8	250ns	12.5V	4.95
27128A-200	16384x8	200ns	12.5V	5.95
27C256	32768x8	250ns	12.5V	7.95
27256	32768x8	250ns	12.5V	5.95
27256-200	32768x8	200ns	12.5V	7.95
27512	65536x8	250ns	12.5V	11.95
27C512	65536x8	250ns	12.5V	12.95
27C101-20	131072x8	200ns	12.5V	34.95

CALL TO CONFIRM CURRENT PRICES

STATIC RAMS

PART	SIZE	SPEED	PRICE
2114	1024x4	450ns	.99
2114L-2	1024x4	200ns	1.49
TC5516	2048x8	250ns	3.95
TMM2016-200	2048x8	200ns	3.25
TMM2016-150	2048x8	150ns	3.29
TMM2016-100	2048x8	100ns	4.29
HM6116-4	2048x8	200ns	4.95
HM6116-3	2048x8	150ns	5.95
HM6116-2	2048x8	120ns	6.45
HM6116P-4	2048x8	200ns	5.95
HM6116P-3	2048x8	150ns	6.45
HM6116P-2	2048x8	120ns	6.95
HM6264L-15	8192x8	150ns	9.95
HM6264L-12	8192x8	120ns	10.95
HM43256LP-15	32768x8	150ns	17.95
HM43256LP-12	32768x8	120ns	19.95
HM43256LP-10	32768x8	100ns	24.95

CALL TO CONFIRM CURRENT PRICES

DYNAMIC RAMS

PART	SIZE	SPEED	PRICE
4116-200	16384x1	200ns	.89
4116-150	16384x1	150ns	.99
4164-150	65536x1	150ns	2.89
4164-120	65536x1	120ns	3.19
4164-100	65536x1	100ns	3.95
TMS4416	16384x4	150ns	8.95
41128-150	131072x1	150ns	5.95
TMS4464-15	65536x4	150ns	14.95
TMS4464-12	65536x4	120ns	15.95
41256-150	262144x1	150ns	7.99
41256-120	262144x1	120ns	8.49
41256-100	262144x1	100ns	8.79
41256-80	262144x1	80ns	9.49
MK4332	32768x1	200ns	6.95
HMS1258-100	262144x1	100ns	13.95
1MB-120	1048576x1	120ns	24.95
1MB-100	1048576x1	100ns	27.95

CALL TO CONFIRM CURRENT PRICES

CO-PROCESSORS

8087	5 MHz	97.95
8087-2	8 MHz	139.95
8087-1	10 MHz	189.95
80287	8 MHz	157.96
80287-8	8 MHz	219.95
80287-10	10 MHz	264.95
80387-16	16 MHz	397.95
80387-SX	16 MHz	389.95
80387-20	20 MHz	469.95
80387-25	25 MHz	589.95



INCLUDES MANUAL & SOFTWARE GUIDE

EPROM ERASERS

DATABASE II #39.95

- SHIRT POCKET SIZE!
- ERASES MOST EPROMS/ EPLD'S IN 3 MINUTES! ALL SIZES UP TO 4 AT A TIME.



Model	Timer	# of Chips	Intensity (uW/Cm ²)	Unit-Cost
PE-140	NO	9	8,000	\$ 89
PE-140T	YES	9	8,000	\$139
PE-240T	YES	12	9,600	\$189
PL-265	YES	30	9,600	\$255

SPECTRONICS CORPORATION

HIGH-TECH SPOTLIGHT

NEW! FAST PAGE-MODE DYNAMIC RAMS

THESE NEW CMOS 262144X4 DRAMS ARE IDEAL FOR LARGE CAPACITY MEMORY SYSTEMS REQUIRING HIGH SPEED AND LOW POWER DISSIPATION. HIGHER DENSITY REQUIRES FEWER CHIPS FOR SYSTEM DESIGN. SUPPORTS EXTREMELY LOW POWER STANDBY MODE. 8 MS REFRESH RATE.

PART NUMBER	SPEED	PRICE
414256-100	100 NS	\$28.95
414256-80	80 NS	\$36.95

SIMM MODULES

41256A8B-15	256K x 8-BIT	FOR MAC	150ns	\$89.00
41256A8B-12	256K x 8-BIT	FOR MAC	120ns	\$95.00
41256A8B-10	256K x 8-BIT	FOR MAC	100ns	\$99.00
41256A9B-15	256K x 9-BIT	FOR PC	150ns	\$94.00
41256A9B-12	256K x 9-BIT	FOR PC	120ns	\$99.00
41256A9B-10	256K x 9-BIT	FOR PC	100ns	\$109.00
41256A9B-80	256K x 9-BIT	FOR PC	80ns	\$119.00
421000A9B-10	1MB x 9-BIT	FOR PC	100ns	\$329.00
421000A9B-80	1MB x 9-BIT	FOR PC	80ns	\$399.00

V-20 SERIES

SPEED UP YOUR PC BY 10% TO 40%
 HIGH SPEED ADDRESS CALCULATION IN HARDWARE ■ PIN COMPATIBLE WITH 8088
 LOW POWER CMOS
 SUPERSSET OF 8088 INSTRUCTION SET

V20 5 MHz	6.95	V20 8 MHz	8.95
V20 10 MHz	11.95	V30 8 MHz	13.95

PALS

16L8	\$2.95	20R4	\$4.95
16R8	2.95	20R6	4.95
16R6	2.95	20R8	4.95
16R4	2.95	20X8	4.95
20L8	4.95		

STARTER KIT

EASY TO USE PAL PROGRAMMING KIT FOR ALL THE PAL DEVICES AT LEFT. MCT-PAL-SOFT \$99.95

PARTIAL LISTINGS ONLY! CALL FOR COMPLETE CATALOG

74 SERIES LOGIC

7400		74LS		74S	
7400	.19	74LS76	.29	74S00	.29
7402	.19	74LS83	.49	74S02	.29
7404	.19	74LS86	.22	74S04	.29
7405	.25	74LS90	.39	74S74	.49
7406	.29	74LS92	.49	74S86	.35
7407	.29	74LS93	.39	74S112	.50
7408	.24	74LS109	.36	74S287	1.69
7410	.19	74LS112	.29	74S288	1.69
7411	.25	74LS123	.49	74S374	1.69
7414	.49	74LS125	.39	S32	.35
7416	.25	74LS132	.39	S138	.79
7417	.25	74LS138	.39	S240	1.49
7420	.19	74LS139	.39	S244	1.49
7432	.29	74LS151	.39	S373	1.69
7447	.89	74LS153	.39		
7473	.34	74LS154	1.49		
7474	.33	74LS155	.59	74F00	.35
7475	.45	74LS156	.49	74F04	.35
7476	.35	74LS157	.35	74F08	.35
7586	.35	74LS158	.29	74F32	.35
7489	2.15	74LS161	.39	74F74	.39
7490	3.19	74LS163	.39	74F138	.79
7493	.35	74LS164	.49	74F244	1.29
74121	.29	74LS165	.65		
74123	.49	74LS166	.95		
74151	.55	74LS175	.39	74HC00	.21
74154	1.49	74LS192	.69	74HC04	.25
74157	.55	74LS193	.69	74HC08	.25
74166	1.00	74LS197	.59	74HC14	.35
		74LS221	.59	74HC22	.35
		74LS240	.69	74HC74	.35
		74LS241	.69	74HC138	.45
		74LS244	.69	74HC139	.45
		74LS245	.79	74HC154	1.09
		74LS251	.49	74HC157	.55
		74LS257	.39	74HC244	.85
		74LS258	.49	74HC245	.85
		74LS259	1.29	74HC373	.69
		74LS311	.22	74LS240	.69
		74LS314	.39	74LS273	.79
		74LS320	.17	74LS279	.39
		74LS321	.22	74LS322	3.95
		74LS327	.23	74LS323	2.49
		74LS330	.17	74LS367	.39
		74LS332	.18	74LS373	.79
		74LS338	.26	74LS374	.79
		74LS342	.39	74LS377	.79
		74LS347	.75	74LS393	.79
		74LS51	.17	74LS541	1.49
		74LS73	.29	74LS670	.89
		74LS74	.24	74LS682	3.20
		74LS75	.29	74LS688	2.40
				74HC374	.99

STD. CMOS LOGIC

4001	.19	4050	.29
4011	.19	4051	.69
4013	.35	4060	.69
4015	.29	4066	.29
4016	.29	4069	.19
4017	.49	4093	.49
4024	.49	14411	9.95
4040	.69	4511	.69
4046	.69	4538	.95
4049	.29	4702	9.95

SHORTING BLOCKS \$1.00

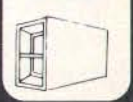

DISCRETE

1N751	.49	2N3904	.10
1N4004	10/1.00	2N3906	.10
1N4148	25/1.00	2N4401	.25
1KBP02	.55	4N62	.69
2N2222	.10	4N35	.69
2N2907	.25	JMBO RED	.10
2N3055	.79	JMBO GRN	.14

BYPASS CAPS

CERAMIC DISC:	
.01UF	100/5.00
.1UF	100/6.50
MONOLITHIC:	
.01UF	100/10.00
.1UF	100/12.50

LINEAR COMPONENTS

TL071	.69	TL497	3.25	MC3487	2.95
TL072	1.09	NE555	.29	LM3900	.49
TL084	1.49	NE556	.49	LM3909	.98
LM301	.34	LM558	.79	LM3914	1.89
LM309K	1.25	LM555	.95	IC7760	1.99
LM311	.59	LM567	.79	7805T	.49
LM311K	3.49	NE570	2.95	7808T	.49
LM317T	.69	NE590	.59	7812T	.49
LM318	1.49	LM723	.49	7815T	.49
LM319	1.25	LM741	.29	7905T	.59
LM323K	3.49	MC1330	1.69	7912T	.59
LM324	.34	MC1350	1.19	7915T	.59
LM334	1.19	LM1458	.35	MAX232	7.95
LM336	1.75	LM1488	.49	ICL8038	3.85
LM338K	4.49	LM1489	.49	ICM7207A	5.95
LM339	.59	LM1496	.85	ICM7208	15.95
LF353	.59	ULN2003	.79	79150	1.95
LF356	.99	XR2206	3.95	79154	1.95
LM358	.59	XR2211	2.95	79188	1.25
LM380	.89	CA3046	.89	79189	1.25
LM386	.85	CA3146	1.29	79451	.39
LM393	.45	MC3470	1.95	79452	.39

MISC.

ADC0804	2.99
ADC0809	3.85
DAC0803	3.29
DAC0808	1.95
7933	9.95
8272	4.39
COM8116	8.95
UPD7655	4.39
1691	6.95
2143	6.95
AYS-3600	
PRO	11.95
AY3-1015	4.95
AY3-1013	3.95
MC146818	5.95
MM58167	9.95
MM58174	9.95
MSM5822	3.95
IM6402	2.95
IM6403	9.95
INS8250	6.95
NS16450	10.95

CRYSTALS

32.768 KHz	.95
1.0 MHz	2.95
1.8432	2.95
2.0	1.95
2.4576	1.95
3.579545	1.95
4.0	1.95

POWER SUPPLIES



- 135 WATT POWER SUPPLY**
 ■ UL APPROVED
 ■ +5V @ 15A, +12V @ 4.2A,
 -5V @ .5A, -12V @ .5A
PS-135 \$59.95
PS-150 150W SUPPLY \$69.95
- 200 WATT POWER SUPPLY**
 ■ UL APPROVED
 ■ +5V @ 20A, +12V @ 7A,
 -5V @ .5A, -12V @ .5A
PS-200 \$89.95
- APPLE TYPE SUPPLY**
 ■ WITH APPLE CONNECTOR
 ■ +5V @ 6A, +12V @ 3A,
 -5V @ 1A, -12V @ 1A
PS-A \$49.95
- 36 WATT POWER SUPPLY**
 ■ +5V @ 2.5A, +12V @ 1.5A
 ■ 3 PIN INPUT, 6 PIN OUTPUT
 ■ SELECTABLE 110V-220V
PS-3045 \$12.95

SOLDER STATIONS



- SOLDER/DESOLDER STATION**
 ■ OIL-FREE VACUUM PUMP
 ■ TEMP ADJUSTS (212° F-900° F)
 & VACUUM (0-60 CM/HG)
 ■ WITH GUN-REST, COOLING TRAY,
 WIRE BRUSH & TIP CLEANER ROD
XY999SD \$399.95
XY999D DESOLDER ONLY \$349.99
- DELUXE SOLDER STATION**
 ■ ROTARY SWITCH TEMP
 CONTROL (200° F-878° F RANGE)
 ■ LED TEMPERATURE READOUTS
 ■ INCLUDES COOLING TRAY
XY9-60L \$79.95
- SOLDER STATION**
 ■ UL APPROVED
 ■ HEAT SETTING ADJUSTS
 ■ TIP TEMPERATURE READOUT
 ■ REPLACEMENT TIPS @ \$2.95
168-3C \$59.95

WIREWAP PROTOTYPE CARDS

FR-4 EPOXY GLASS LAMINATE WITH GOLD PLATED
EDGE CARD FINGERS AND SILK SCREENED LEGENDS



- FOR XT**
JDR-PR1 WITH +5V AND GROUND PLANE \$27.95
JDR-PR2 ABOVE WITH I/O DECODING LAYOUT \$29.95
- FOR AT**
JDR-PR10 16 BIT WITH I/O DECODING LAYOUT \$34.95
JDR-PR10PK PARTS KIT FOR JDR-PR10 ABOVE \$12.95
- FOR PS/2**
JDR-PR32 32 BIT PROTOTYPE CARD \$69.95
JDR-PR16 16 BIT WITH I/O DECODING LAYOUT \$49.95
JDR-PR16PK PARTS KIT FOR JDR-PR16 ABOVE \$15.95
JDR-PR16V 16 BIT FOR VIDEO APPLICATIONS \$39.95

JDR INSTRUMENTS—2 YEAR WARRANTY!

- 35 MHZ DUAL TRACE OSCILLOSCOPE**
 ■ WIDE BAND WIDTH ■ VARIABLE HOLDOFF
MODEL-3500 (SHOWN) \$499.95
- 20 MHZ DUAL TRACE OSCILLOSCOPE**
 ■ TV SYNC FILTER ■ COMPONENTS TESTER
MODEL 2000 \$389.95
- 3.5 DIGIT PROBE TYPE DMM**
 ■ AUTORANGING ■ AC/DC 2V - 500V, RESIS. 2K-2M
DPM-1000 (SHOWN) \$54.95
- 3.5 DIGIT POCKET SIZE DMM**
 ■ BASIC DC ACCURACY ±0.5% ■ 14 RANGES
DMM-100 \$29.95
- 3.5 DIGIT FULL FUNCTION DMM**
 ■ BASIC DC ACCURACY ±0.25% ■ 22 RANGES
DMM-200 \$49.95
- THE ULTIMATE 3.5 DIGIT DMM**
 ■ BASIC DC ACCURACY ±0.25% ■ 34 RANGES
 ■ TEMP, TRANSISTOR & RESISTANCE FEATURES
DMM-300 (SHOWN) \$79.95



RELIABLE,
HIGH QUALITY
TEST EQUIPMENT,
REASONABLY
PRICED

DATA SWITCH BOXES

TYPE	# OF POS.	PARALL.	SERIAL	PRICE
PUSH/BTN	2-WAY	AB-P	AB-S	39.95
ROTARY	2-WAY	RSP-2	RSS-2	24.95
ROTARY	3-WAY	RSP-3	RSS-3	27.95
ROTARY	4-WAY	RSP-4	RSS-4	29.95

EXTENDER CARDS

FOR PROTOTYPE DEBUGGING,
TESTING AND TROUBLESHOOTING

- EXT-8088** XT COMPATIBLE \$29.95
EXT-80286 AT COMPATIBLE \$39.95
EXT-16 MICROCHANNEL 16-BIT \$69.95
EXT-32 MICROCHANNEL 32-BIT \$99.95



COMPUTER CABLES

- GOLD-PLATED CONTACTS; 100% SHIELDED**
- CBL-PRINTER** PC PRINTER CABLE 9.95
CBL-PRINTER-25 AS ABOVE-25 FT. 15.95
CBL-PRINTER-RA RT. ANGL. PRINTER 15.95
CBL-DB25-MM DB25 MALE-MALE 9.95
CBL-DB25-MF DB25 MALE-FEMALE 9.95
CBL-9-SERIAL 9 PIN-25 PIN SERIAL 6.95
CBL-KBD-EXT KEYBOARD EXTEN. 7.95
CBL-CNT-MM 36 PIN CENTRON.-M/M 14.95
CBL-HD-20 20 PIN HARD DISK 3.95
CBL-HD-34D 34 PIN DUAL HARD DISK 6.95
CBL-FDC-EXT 37 PIN EXT. FLOPPY 9.95
CBL-MNT-9 9 PIN MONITOR EXTEN. 6.95
CBL-MODEM DB25-DB25 FEMALE 7.95

NEW LOW PRICES! SOLDERLESS BREADBOARDS

- PDS-100** 1360 TIE PTS \$12.95
PDS-200 1660 TIE PTS \$19.95
PDS-300 2390 TIE PTS \$24.95
PDS-400 3220 TIE PTS \$34.95



IDC CONNECTORS/RIBBON CABLE

DESCRIPTION	ORDER BY	CONTACTS					
		10	20	26	34	40	50
SOLDER HEADER	IDHxxS	.82	1.29	1.68	2.20	2.58	3.24
RIGHT ANGLE SOLDER HEADER	IDHxxSR	.85	1.35	1.76	2.31	2.72	3.39
WIREWAP HEADER	IDHxxW	1.86	2.98	3.84	4.50	5.28	6.63
RIGHT ANGLE WIREWAP HEADER	IDHxxWR	2.05	3.28	4.22	4.45	4.80	7.30
RIBBON HEADER SOCKET	IDSxx	.63	.89	.95	1.29	1.49	1.89
RIBBON HEADER	IDMxx	--	5.50	6.25	7.00	7.50	8.50
RIBBON EDGE CARD	IDExx	.85	1.25	1.35	1.75	2.05	2.45
10' RIBBON CABLE	RCxx	1.60	3.20	4.10	5.40	6.40	7.50

FOR ORDERING INSTRUCTIONS, SEE D-SUBMINIATURE CONNECTORS BELOW

RS-232 BREAKOUT BOX

FOR TROUBLESHOOTING
SERIAL COMMUNICATIONS

- OPEN/CLOSE INDIVIDUAL
CIRCUITS ■ 20 JUMPERS
CROSS-CONNECT ANY TWO
CIRCUITS ■ 10 CIRCUIT
ACTIVITY LEDS
GENDER-BO \$34.95



SURGE SUPPRESSOR

- PROTECTS YOUR EQUIPMENT!**
 ■ SIX 3-PRONG AC OUTLETS
 ■ 15 AMP CIRCUIT BREAKER
 ■ 6' HEAVY DUTY CORD
 ■ 15 AMP MAX LOAD, 1875 WATTS
 ■ UL APPROVED
POWER-SURGE \$12.95
POWER-STRIP W/O SURGE \$9.95



PC BREADBOARD



- 62 CLEARLY LABELLED BUS LINES
 ■ ACCEPTS UP TO 24 14-PIN ICs
 ■ 1940 TIE POINTS
 ■ EXT FEMALE DB25 D-SUB CONNECT.
PDS-604 \$49.95

D-SUBMINIATURE CONNECTORS

DESCRIPTION	ORDER BY	CONTACTS						
		9	15	19	25	37	50	
SOLDER CUP	MALE	DBxxP	.45	.59	.69	.69	1.35	1.85
	FEMALE	DBxxS	.49	.69	.75	.75	1.39	2.29
RIGHT ANGLE PC SOLDER	MALE	DBxxPR	.49	.69	--	.79	2.27	--
	FEMALE	DBxxSR	.55	.75	--	.85	2.49	--
WIREWAP	MALE	DBxxPWW	1.69	2.56	--	3.89	5.60	--
	FEMALE	DBxxSww	2.76	4.27	--	6.84	9.95	--
IDC RIBBON CABLE	MALE	IDBxxP	1.39	1.99	--	2.25	4.25	--
	FEMALE	IDBxxS	1.45	2.05	--	2.35	4.49	--
HOODS	METAL	MHOODxx	1.05	1.15	1.25	1.25	--	--
	PLASTIC	HOODxx	.39	.39	--	.39	.69	.75

ORDERING INSTRUCTIONS: INSERT THE NUMBER OF CONTACTS IN THE POSITION MARKED "xx" OF THE "ORDER BY" PART NUMBER LISTED. EXAMPLE: A 15 PIN RIGHT ANGLE MALE PC SOLDER WOULD BE DB15PR

MOUNTING HARDWARE .59

LITHIUM BATTERY

- 6V FOR 286 AND 386 PCS
 ■ MOTHERBOARD CONNECTOR
 ■ ADHESIVE VELCRO MOUNTING
 STRIP
LITHIUM6.8V \$11.95



- COIN TYPE BATTERY**
 LONG-LASTING 3V LITHIUM
3V-MHW \$1.95
HOLDER \$1.49

APPLE-COMPATIBLE PRODUCTS

- FLOPPY DRIVE FOR APPLE II SERIES**
AP-150 (W/CABLE, CONNECTOR) \$99.95
- REPLACEMENT KEYBOARD FOR APPLE II & II+**
KEYBOARD-AP \$59.95
- EPROM PROGRAMMER. NOT REC. FOR CMOS.**
PR-525 (NO POWER SUPPLY REQ.) \$89.95
- 16K RAM CARD BOOSTS 48K APPLE TO 64K**
RAM-CARD (2 YEAR WARRANTY) \$39.95

"SNAPABLE HEADERS"

SNAP APART TO MAKE ANY SIZE
HEADER, WITH .1" CENTERS

- 1 X 40** STRAIGHT LEAD .99
1 X 40 RIGHT ANGLE LEAD \$1.49
2 X 40 STRAIGHT LEAD \$2.49
2 X 40 RIGHT ANGLE LEAD \$2.99

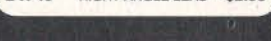

VISA

MasterCard

MEMBER

ASSOCIATION

MEMBER

ASSOCIATION

MEMBER

ASSOCIATION

JDR MICRODEVICES, 2233 BRANHAM LANE, SAN JOSE, CA 95124
 LOCAL (408) 866-6200 FAX (408) 559-0250 TELEX 171-110
 RETAIL STORE: 1256 S. BASCOM AVE., SAN JOSE, CA
 (408) 947-8881 HOURS: M-F, 9-7 SAT. 9-5 SUN. 12-4

NEW
ADDRESS!

Terms: Minimum order \$10.00. For shipping & handling include \$3.50 for ground and \$4.50 for air. Orders over 1 lb and foreign orders may require additional shipping charges—contact the sales department for the amount. CA residents must include applicable sales tax. Prices subject to change without notice. We are not responsible for typographical errors. We reserve the right to limit quantities and to substitute manufacturer. All merchandise subject to prior sales. A full copy of our terms is available upon request. Items pictured may only be representative.

ORDER TOLL FREE 800-538-5000

Copyright 1989 JDR Microdevices

CONTINENTAL U.S.

JDR Microdevices

MMC
MICROCOMPUTER
MARKETING COUNCIL
of the Direct Marketing Association, Inc.

• 30 DAY MONEY BACK GUARANTEE • 1 YEAR WARRANTY ON ALL PRODUCTS • TOLL-FREE TECHNICAL SUPPORT
• COMPLETE CUSTOMER SATISFACTION • SUPERIOR SERVICE • FRIENDLY, KNOWLEDGEABLE SALES STAFF

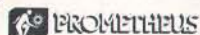

2400 BAUD MODEM

\$99⁹⁵

- HAYES COMPATIBILITY ■ 1/2-CARD ■ AUTO DIAL/ANSWER
- SELF-TEST ON POWER UP ■ FULL AND HALF DUPLEX
- TOUCHTONE OR PULSE DIALING ■ 2ND PHONE JACK
- CALL PROGRESS MONITORING ■ ADJUSTABLE VOLUME

INTERNAL MODEMS (MIRHOR II SOFTWARE INCLUDED)
PRO-121 1200 BAUD 1/2 CARD \$69.95
PRO-24M 2400 BAUD FOR PS/2 \$249.95

EXTERNAL MODEMS REQ. SERIAL PT, CABLE, SOFTWARE
PRO-24E 2400 BAUD \$149.95
PRO-12E 1200 BAUD \$99.95

APPLE/MACINTOSH COMPATIBLE MODEMS

EXTERNAL MODEMS, AS ABOVE WITH CABLE & SOFTWARE
PRO-24EM MAC 2400 BAUD \$199.95
PRO-24A APPLE II 2400 BAUD \$179.95
PRO-12A APPLE II 1200 BAUD \$139.95

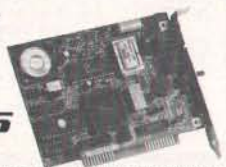

VGA COMPATIBLE PACKAGE

\$549⁹⁵

- 800 X 560 MAXIMUM RESOLUTION
- 640 X 480 IN 16 COLORS
- 320 X 200 IN 256 COLORS
- IBM STYLE MONITOR
- VGA, EGA, CGA, HERCULES, MONOCHROME COMPATIBLE
- VGA-PKG (INCLUDES ATI CARD AND MONITOR)

NEC MULTISYNC II \$599.95

- AUTO FREQ. ADJUSTMENT ■ RESOLUTION TO 800 X 560
- IDEAL FOR CAD, CAM, WINDOWS ■ 9-15 PIN ADAPTER

JDR MULTI \$499.95

- FULL FEATURED MULTISCAN MONITOR WITH UNLIMITED COLORS ■ HIGH RESOLUTION, 14" NON-GLARE DISPLAY
- AUTO SWITCHING ■ TTL/ANALOG VIDEO INPUT

JDR-MULTI 12" MONOCHROME MONITOR \$69.95

EGA MONITOR \$399.95

- 640 X 200/350 RESOLUTION ■ 16 COLOR DISPLAY ■ 31MM DOT PITCH ■ 14" BLACK MATRIX SCREEN ■ 9-PIN CABLE

SAVE \$50! EGA CARD & MONITOR \$499

RGB MONITOR \$269.95

- COLOR/GREEN/AMBER SWITCH ■ .41MM DOT PITCH
- 640 X200 MONOCHROME RESOLUTION, 320 X 200 COLOR
- 14" NON-GLARE SCREEN ■ TILT/SWIVEL BASE

FLAT SCREEN \$139.95

- LOW DISTORTION, 14" GLARE-RESISTANT AMBER SCREEN
- 720 X 350 MAXIMUM RESOLUTION ■ IBM COMPATIBLE TTL INPUT ■ SWIVEL BASE

GM-1488 MONO-SAMSUNG WITH 12" SCREEN \$129.95

TILT & SWIVEL MONITOR STANDS

MS-100 DURABLE PLASTIC \$12.95
MS-200 WITH 5 OUTLETS & SURGE SUPPRESSOR \$39.95

HIGH QUALITY KEYBOARDS

101 KEY ENHANCED, W/SEPARATE CURSOR PAD:
BTC-5339 AUTOSENSE FOR XT/AT, AUTOREPEAT \$69.95
K103-A AUDIBLE "CLICK" STYLE \$84.95
MAX-5339 MAXI-SWITCH W/TACTILE FEEDBACK \$84.95

84 KEY STYLES:
BTC-5060 AUTOSENSE FOR XT/AT \$59.95
MAX-5060 MAXI-SWITCH W/TACTILE FEEDBACK \$64.95

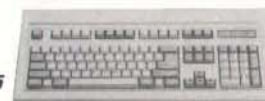

UPRIGHT CASE \$299⁹⁵

SPACESAVING DESIGN HOLDS ALL SIZES OF MOTHERBOARDS AND INCLUDES:

- 250W POWER SUPPLY ■ MOUNTS FOR 3 FLOPPY & 4 HARD DRIVES
- TURBO & RESET SWITCH ■ LED SPEED DISPLAY ■ POWER & DISK LED'S
- ALL HARDWARE, FACEPLATES & SPEAKER

CASE-100 \$39.95
CASE-FLIP FOR 8088 BOARDS \$39.95
CASE-SLIDE FOR 8088 BOARDS \$39.95
CASE-70 FOR 286 BOARDS \$89.95
CASE-50 FOR 8088/286 BOARDS \$59.95
CASE-JR MINI 286 W/150W PS \$149.95



LOGITECH HIREZ MOUSE

\$89⁹⁵

- HIGH RESOLUTION BUS MOUSE FOR BETTER RESPONSE, LESS MOVEMENT
- 320 DPI ■ WITH DRIVER, TEXT EDITOR & POP-UP MENUS ■ NO PAD, POWER SUPPLY OR PORT REQUIRED

LOGITECH 3 BUTTON MOUSE
PC MAGAZINE EDITORS' CHOICE! ALL MODELS HAVE SERIAL SUPPORT (COM1/COM2), 200 D.P.I. RESOLUTION, LOTUS 1-2-3 SHELL, SELF-INSTALLING SOFTWARE AND "POINT EDITOR"

LMOUSE \$74.95
LMOUSE-P SERIAL MOUSE W/LOGIPAINIT \$89.95
LMOUSE-BP BUS MOUSE W/LOGIPAINIT \$89.95
LMOUSE-BPBL BUS MOUSE W/PUBLISHER PKG \$129.95
LMOUSE-BPC BUS MOUSE W/LOGIPAINIT/CAD \$139.95



MODULAR PROGRAMMING SYSTEM

OUR INTEGRATED MODULAR PROGRAMMING SYSTEM EASILY EXPANDS! ALL THE MODULES USE A COMMON HOST ADAPTOR CARD, SO YOU CAN USE JUST ONE SLOT TO PROGRAM EPROMS, PROMS, PALS & MORE!

HOST ADAPTOR CARD \$29.95

- UNIVERSAL INTERFACE FOR ALL THE PROGRAMMING MODULES!
- SELECTABLE ADDRESSES PREVENTS CONFLICTS
- HIGH QUALITY MOLDED CABLE

UNIVERSAL MODULE \$499.95

- PROGRAMS EPROMS, EEPROMS, PALS, BI-POLAR PROMS, 8748 & 8751 SERIES DEVICES, 16V8 & 20V8 GAL'S (GENERIC ARRAY LOGIC) FROM LATTICE, NS, SGS ■ TESTS TTL, CMOS, DYNAMIC & STATIC RAMS ■ LOAD DISK, SAVE DISK, EDIT, BLANK CHECK, PROGRAM, AUTO, READ MASTER, VERIFY & COMPARE
- TEXT/TOOL SOCKET FOR .3" TO .6" W. IC'S (8-40 PINS)



EPROM MODULE \$119.95

- PROGRAMS 24-32 PIN EPROMS, CMOS EPROMS & EEPROMS FROM 16K TO 1024K ■ HEX TO OBJ CONVERTER ■ AUTO, BLANK CHECK/PROGRAM/VERIFY ■ VPP 5, 12.5, 12.75, 13, 21 & 25 VOLTS
- NORMAL, INTELLIGENT, INTERACTIVE, & QUICK PULSE PROGRAMMING ALGORITHMS

MOD-MEP \$169.95
MOD-MEP-4 4-EPROM PROGRAMMER \$169.95
MOD-MEP-8 8-EPROM PROGRAMMER \$259.95
MOD-MEP-16 16-EPROM PROGRAMMER \$499.95

DIGITAL IC MODULE \$129.95

- TESTS TTL, CMOS, DYNAMIC & STATIC RAM
- AUTO SEARCH FOR UNKNOWN PART NUMBERS
- USER-PROGRAMMABLE TEST PROCEDURES

PAL MODULE \$249.95

- PROGRAMS MMI, NS, TI 20 & TI 24 PIN DEVICES
- BLANK CHECK, PROGRAM, AUTO, READMASTER, VERIFY & SECURITY FUSE BLOW

MOD-MPL PAL PROGRAMMING DEVELOPMENT SOFTWARE \$99.95
MOD-MPL-SOFT

20 MB \$269 30 MB \$299



KITS INCLUDE A SEAGATE HARD DISK DRIVE, DRIVE CONTROLLER, CABLES AND INSTRUCTIONS.
HDKIT20 20 MB SYSTEM KIT
HDKIT30 30 MB SYSTEM KIT



FAST, RELIABLE SEAGATE HARD DISKS:

DISK SIZE	MODEL	AVG. SPD.	SIZE	PRICE
20MB	ST-125	65 MS	3-1/2"	\$259
20MB	ST-225	65 MS	5-1/4"	\$225
30MB RLL	ST-238	65 MS	5-1/4"	\$248
40MB	ST-251	40 MS	5-1/4"	\$379
40MB	ST-251-1	28 MS	5-1/4"	\$469
60MB RLL	ST-277	40 MS	5-1/4"	\$449
80MB	ST-4096	28 MS	5-1/4"	\$629

1 Mb 3 1/2" DRIVE

\$99⁹⁵



- ULTRA HIGH DENSITY
- READ/WRITE 720K DISKS, TOO
- FDD-1.44X BLACK FACEPLATE
- FDD-1.44A BEIGE FACEPLATE
- FDD-1.44 SOFT SOFTWARE DRIVER \$19.95

1/2 HEIGHT FLOPPY DISK DRIVES:

FD-55B 5-1/4" TEAC DS/DD 360K \$99.95
FD-55G 5-1/4" TEAC DS/HD 1.2M \$129.95
FDD-360 5-1/4" DS/DD 360K \$69.95
FDD-1.2 5-1/4" DS/HD 1.2M \$95.95
FDD-3.5X 3-1/2" 720K (BLACK) \$97.95
FDD-3.5A 3-1/2" 720K (BEIGE) \$97.95

NASHUA DISKETTES (BOXES OF 10):

N-MD2D 360K DS/DD \$6.95
N-MD2D BULK (MULTIPLES OF 50 DISKS) EACH .49
N-MD2H 1.2 MB DS/HD \$13.95
N-3.5HD 1.44 MB 3-1/2" DS/HD \$49.95
N-3.5DS 720K 3-1/2" DD/DS \$16.95

TAPE BACK-UP DRIVES & DRIVE ACCESSORIES:

AR5240X ARCHIVE DRIVE XT'S & AT'S \$369.95
AR5540A FASTER DRIVE-AT'S ONLY \$369.95
AR340 40 MB TAPE CARTRIDGES \$24.95

FD-ARAIL MTG. RAILS FOR AT COMPATIBLE \$2.95
FD-55MHW HALF-HT. MOUNTING HARDWARE \$2.95
FD-5Y Y-POWER ADAPTOR FOR DRIVES \$2.95
FD55P BEIGE FACEPLATE FOR TEAC DRIVES \$2.95

MOTHERBOARDS

NEW LOW PRICES!

TURBO 4.77/8 MHZ \$95.95

■ XT COMPATIBLE ■ NORTON SI 1.7 ■ 4.77 OR 8 MHZ WITH 8088-2 AND OPTIONAL 8087-2 CO-PROCESSOR

10 MHZ SINGLE CHIP \$99.95

■ XT COMPATIBLE ■ NORTON SI 2.1 ■ USES LESS POWER ■ KEY-SELECTABLE 4.77 OR 10 MHZ

10 MHZ MINI-286 \$269.95

■ AT COMPATIBLE ■ ONLY 8-1/2 X 13" ■ 80286 MICRO-PROCESSOR ■ LANDMARK AT SPEED 15.5 MHZ, NORTON SI 13.8 ■ 6, 10, 12 MHZ; KEYBOARD SELECT

12 MHZ MINI-286 \$299.95

■ AT COMPATIBLE ■ ONLY 8-1/2 X 13" ■ 80286 MICRO-PROCESSOR ■ LANDMARK AT SPEED 15.5 MHZ, NORTON SI 13.8 ■ 6, 10, 12 MHZ; KEYBOARD SELECT ■ ZYMO'S POACH CHIP SET ■ AWARD BIOS

EPROM PROGRAMMER \$129.95

- PROGRAMS 27XX AND 27XXX EPROMS UP TO 27512
- SUPPORTS VARIOUS PROGRAMMING FORMATS & VOLTAGES ■ SPLIT OR COMBINE CONTENTS OF SEVERAL EPROMS OF DIFFERENT SIZES
- READ, WRITE, COPY, ERASE, CHECK & VERIFY
- SOFTWARE FOR HEX AND INTEL HEX FORMATS



DFI HANDY SCANNER

400 DPI \$199.95

INSTANTLY SCANS UP TO 4.1" W. IMAGES ■ 100, 200, 300, 400 DPI BOTH DIRECTIONS ■ B&W & 3 HALF-TONE MODES ■ 32 LEVELS OF GRAY SCALE ■ HERCULES, CGA, EGA & VGA COMPATIBLE ■ INCLUDES HALO DPE AND IMAGE EDITOR SOFTWARE HS-3000

OCR-SOFT SOFTWARE \$99.95



NEW LOW PRICE!

BUILD YOUR OWN SYSTEM!

OVER 25,000 JDR SYSTEMS HAVE BEEN BUILT.

OUR DETAILED INSTRUCTIONS MAKE IT VERY EASY—ALL YOU NEED IS ABOUT 2 HOURS AND A SCREWDRIVER!



VIDEO INSTRUCTIONS \$4.95 WITH SYSTEM
OUR 20 MINUTE VIDEO SHOWS YOU STEP-BY-STEP HOW TO BUILD AN XT-COMPATIBLE SYSTEM. SPECIFY VHS OR BETA. VIDEO WITH SYSTEM KIT, \$4.95 VIDEO ALONE, 19.95

10 MHz TURBO 8088 SYSTEM \$595.86
■ SERIAL/PARALLEL PORTS, CLOCK/CALENDAR & GAME ADAPTOR ■ RUNS COLOR GRAPHICS SOFTWARE ON ITS MONOCHROME MONITOR ■ MOTHERBOARD ■ 256K RAM MEMORY ■ 135W POWER SUPPLY ■ FLIPTOP CASE ■ 84 KEY KEY-BOARD ■ 360K FLOPPY DRIVE ■ MONOGRAPHS I/O CARD

12 MHz MINI-286 SYSTEM \$1038.47
■ 12 MHz MINI-286 MOTHERBOARD ■ 512K RAM MEMORY ■ MINI-AT CASE W/POWER SUPPLY ■ 84 KEY KEYBOARD ■ MONOCHROME MONITOR ■ 1.2 MB FLOPPY DRIVE ■ FLOPPY/HARD CONTROL ■ MONOGRAPHS CARD

EPSON PRICES SO LOW, WE CAN'T PRINT THEM!

JDR CARRIES A FULL LINE OF QUALITY EPSON PRINTERS. WE CAN'T ADVERTISE OUR LOW PRICES—CALL OUR SALES DEPARTMENT FOR A PRICE QUOTE TODAY: 1-800-538-5000 TOLL-FREE!



EPSON LQ-2550 CALL FOR THE PRICE!
(SHOWN) ■ 132-COLUMN CARRIAGE, SUPER FAST OUTPUT ■ 24-PIN PRINT HEAD, 8K MEMORY BUFFER ■ 400 CPS DRAFT, 133 CPS LQ ■ PRINTS UP TO 7 COLORS ■ SEVEN FONTS ■ PARALLEL & SERIAL INTERFACES

EPSON LQ-950 CALL FOR THE PRICE!
■ 24-PIN PRINT HEAD, 8K MEMORY BUFFER ■ 110-COL. CARRIAGE ■ 264 CPS DRAFT, 88 CPS LQ ■ 360 X 360 DPI GRAPHICS RESOL. ■ PARALLEL AND SERIAL INTERFACES

EPSON LQ-850 CALL FOR THE PRICE!
■ 24-PIN PRINT HEAD, 6K MEMORY BUFFER ■ 80-COL. CARRIAGE ■ 264 CPS DRAFT, 88 CPS LQ ■ BIDIRECTIONAL TEXT & GRAPHICS ■ PARALLEL AND SERIAL INTERFACES

EPSON LQ-500 CALL FOR THE PRICE!
■ 24-PIN PRINT HEAD, 8K MEMORY BUFFER ■ 80-COL. CARRIAGE ■ 180 CPS DRAFT, 60 CPS LQ ■ BIDIRECTIONAL TEXT & GRAPHICS ■ PARALLEL INTERFACE (SERIAL OPT.)

EPSON FX-850 CALL FOR THE PRICE!
FOR FORMS, ENVELOPES, FANFOLDS! ■ 80-COL. CARRIAGE ■ 264 CPS DRAFT, 54 CPS NLQ ■ 9-PIN PRINT HEAD, 8K MEMORY BUFFER ■ AUTO LOAD ■ PARALLEL INTERFACE FX-1050 WITH 136-COLUMN CARRIAGE **SCALL!**

EPSON EX-800 CALL FOR THE PRICE!
■ 9-PIN PRINT HEAD, 8K MEMORY BUFFER ■ 80-COLUMN CARRIAGE ■ 300 CPS DRAFT, 50 CPS NLQ ■ BIDIRECTIONAL TEXT MODE ■ PARALLEL & SERIAL INTERFACES

EPSON LX-800 CALL FOR THE PRICE!
■ 9-PIN DOT MATRIX PRINT HEAD, 3K MEMORY BUFFER ■ 80-COL. CARRIAGE ■ 180 CPS DRAFT, 30 CPS NLQ MODE ■ PARALLEL INTERFACE (SERIAL OPTIONAL.)

24-HR. ON-LINE ORDERING!

(408) 559-0253

JDR'S ELECTRONIC BULLETIN BOARD OFFERS TECHNICAL SUPPORT, CONFERENCING AND MORE

CALL FOR A FREE COPY OF OUR 84-PG CATALOG

IT'S OUR 10TH ANNIVERSARY EDITION— FILLED WITH GREAT VALUES!

BARGAIN HUNTERS' CORNER
SAVE \$50
UPRIGHT CASE

REGULARLY \$299.95
CASE STANDS ON THE FLOOR—FREES UP DESK SPACE!
■ ACCEPTS 8088, MINI 286 AND STANDARD 286/386 MOTHERBOARDS
■ INCLUDES 250 WATT POWER SUPPLY
■ POWER MOUNTS FOR THREE FLOPPY, 4 HARD DRIVES
■ 16-3/4" L X 7" W X 24-3/4" H.
CASE-100 OFFER EXPIRES 7/31/89

\$249.95

INTERFACE CARDS MODULAR CIRCUIT TECHNOLOGY

DISPLAY ADAPTOR

MONOCHROME GRAPHICS \$59.95
■ HERCULES COMPAT. SUPPORTS LOTUS 1-2-3 ■ VLSI CHIPS ■ PARALLEL PRINTER PORT CONFIG. AS LPT1 OR 2 MCT-MGP

COLOR GRAPHICS ADAPTOR \$49.95
■ IBM COMPATIBLE ■ FOR RGB, COLOR AND COMPOSITE MONO ■ 640/320 X 200 RESOLUTION WITH LIGHT PEN INTERFACE MCT-CG

ENHANCED GRAPHICS ADAPTOR \$149.95
■ IBM COMPATIBLE, PASSES IBM EGA DIAGNOSTICS ■ 256K OF VIDEO RAM FOR 640 X 350 IN 16 OF 64 COLORS ■ HERCULES COMPATIBLE MCT-EGA

MONOGRAPHS MULTI I/O \$119.75
■ CONTROL 2 FLOPPIES, SERIAL, PARALLEL, GAME PORT, CAL CLOCK ■ RUN COLOR GRAPHICS SOFTWARE ON YOUR MONOCHROME MONITOR MCT-MGMI0

286/386 MONOGRAPHS I/O \$99.95
■ HOOK UP A MONOCHROME MONITOR, PARALLEL PRINTER, MODEM AND JOYSTICK ALL AT ONCE! ■ ONLY OTHER CARD YOUR SYSTEM NEEDS IS A FLOPPY/HARD CONTROLLER ■ AT COMPATIBLE ■ 720 X348 RESOLUTION, 80 & 132 COLUMN TEXT ■ PARALLEL, SERIAL AND GAME PORTS ■ HERCULES COMPATIBLE MONOGRAPHS ■ WITH SOFTWARE TO RUN COLOR GRAPHICS ON A MONOCHROME MONITOR MCT-MGAIO

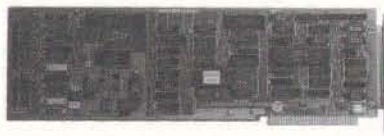
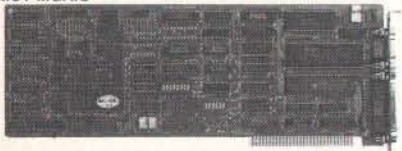

DRIVE CONTROLLERS

FLOPPY/HARD CONTROLLER \$139.95
■ FREES 1 SLOT IN YOUR XT SYSTEM ■ INTERFACES 2 FDD'S AND 2 HDD'S; CABLING FOR 2 FDD, 1 HDD MCT-FH (SHOWN)

FLOPPY DISK CONTROLLER \$29.95
■ 1 SLOT CONTROL OF 4 FLOPPIES ■ INTERFACES UP TO 4 FDD'S TO IBM PC OR COMPATIBLE ■ DS/DD & DS/OD MCT-FDC

1.2 MB FLOPPY CONTROLLER \$49.95
■ SUPPORTS 2 DRIVES, CAN MIX 360K AND 1.2MB ■ LETS DATA FLOW FREELY FROM XT'S TO AT'S MCT-FDC-1.2

HARD DISK CONTROLLER \$79.95
■ SUPPORTS 16 DRIVE SIZES, INCLUDING 10, 20, 30, 40 MB ■ DIVIDES 1 LARGE DRIVE INTO TWO LOGICAL DRIVES MCT-HDC

RLL CONTROLLER \$89.95
■ TRANSFERS DATA 50% FASTER! ■ SUPPORTS UP TO 2 RLL HARD DRIVES ■ FOR XT COMPATIBLES MCT-RLL

286/386 FLOPPY/HARD \$149.95
■ TRUE AT DESIGN ■ SUPPORTS UP TO TWO 360K/720K/1.2MB/1.44MB FDD'S ■ SUPPORTS 2 HDD'S (STD. TABLES) MCT-AFH

286/386 RLL CONTROLLER \$199.95
■ SUPPORTS UP TO 2 RLL HARD DRIVES AND 2 FLOPPIES ■ SUPPORTS 360/720/1.2/1.44 MB FLOPPIES (5-1/2" & 3-1/2") MCT-AFH-RLL

MULTIFUNCTION CARDS

MULTI I/O FLOPPY CONTROLLER \$79.95
■ SUPPORTS UP TO 2 360K FLOPPIES, 720K W/ DOS 3.2 ■ SERIAL, PARALLEL, GAME PORT, CLOCK/CALENDAR MCT-MIO

MULTI I/O CARD \$59.95
■ SERIAL PORT, CLOCK/CALENDAR W/BATTERY ■ PARALLEL PORT IS ADDRESSABLE AS LPT1 OR LPT2 MCT-IO

286/386 MULTIFUNCTION \$139.95
■ ADDS 1.5MB (3 MB WITH OPTIONAL PIGGYBACK CARD, OK INSTALLED) TO YOUR AT ■ INCLUDES SERIAL AND PARALLEL PORTS

MCT-AMF \$29.95
MCT-AMF-MC 1.5MB PIGGYBACK BOARD \$29.95
AIO-SERIAL 2ND SERIAL PORT \$24.95

286/386 MULTI I/O CARD \$59.95
■ SERIAL, PARALLEL AND GAME PORTS ■ USES 16450 SERIAL SUPPORT CHIPS FOR HIGH SPEED OPERATION MCT-AIO



MEMORY CARDS

576K RAM CARD \$59.95
■ SHORT SLOT ■ USER SELECTABLE CONFIGURATION TO 576K ■ 64K AND 256K RAM CHIPS (OK INSTALLED) MCT-RAM

EXPANDED MEMORY CARD \$129.95
■ 2MB LIM MEMORY (OK INSTALLED) ■ USER EXPANDABLE TO 2 MB ■ CONFORMS TO LOTUS INTEL EMS MCT-EMS (SHOWN)

MCT-AEMS 286/386 EMS CARD \$139.95

JDR MICRODEVICES, 2233 BRANHAM LANE, SAN JOSE, CA 95124
LOCAL (408) 866-6200 FAX (408) 559-0250 TELEX 171-110
RETAIL STORE: 1256 S. BASCOM AVE., SAN JOSE, CA
(408) 947-8881 HOURS: M-F, 9-7 SAT. 9-5 SUN. 12-4

NEW ADDRESS!

Terms: Minimum order \$10.00. For shipping & handling include \$3.50 for ground and \$4.50 for air. Orders over 1 lb and foreign orders may require additional shipping charges—please contact the sales department for the amount. CA residents must include applicable sales tax. Prices subject to change without notice. We are not responsible for typographical errors. We reserve the right to limit quantities and to substitute manufacturer. All merchandise subject to prior sales. A full copy of our terms is available upon request. Items pictured may only be representative.

MMC MICROCOMPUTER SYSTEMS

ORDER TOLL FREE 800-538-5000

COPYRIGHT 1989 JDR MICRODEVICES

CONTINENTAL US

EDITORIAL INDEX BY COMPANY

Index of companies covered in articles, columns, or news stories in this issue
Each reference is to the first page of the article or section in which the company name appears

INQUIRY #	COMPANY	PAGE	INQUIRY #	COMPANY	PAGE	INQUIRY #	COMPANY	PAGE
1106	ABRAXAS SOFTWARE	80	991	DIGITECH			LAWRENCE ERLBAUM ASSOCIATES	13
997	ADVANCED COMPUTER SECURITY CONCEPTS	290	1038	TELECOMMUNICATIONS	290	1025	LIFETREE SOFTWARE	97
	ADVANCED LOGIC RESEARCH	109	1168	DISTRIBUTED PROCESSING TECHNOLOGY	65, 119, 313	859	LOGITECH	187
	ALAMEDA COLLEGE	275	1133				LOTUS DEVELOPMENT	13
1143	ALLOY COMPUTER PRODUCTS	65	1030	DTG	97		MACMOTION	13
1115	ALPHA SOFTWARE	80		E-MACHINES	13	1150	MADGE NETWORKS	65
994	AMERICAN COMPUTER SECURITY INDUSTRIES	285, 290	1073	E-TECH RESEARCH	162	1007	MAGNA	290
1162	AOX	313	867	ENIGMA LOGIC	290	1017	MAINSTAY	290
861	APPLE COMPUTER		1122	EVOLUTION COMPUTING	80	866	MCTEL	290
	APPLE DEVELOPERS' ASSOCIATION	13, 146, 175, 235		FARALLON	235	1126	MICRO EXPRESS	65
1121	APTECH SYSTEMS	80	1028	FARPOINT SYSTEMS	97	873	MICRO SECURITY SYSTEMS	290
1103	ARIEL	80	1074	FASTCOMM COMMUNICATIONS	162	1079	MICROCOM	162
1163	AST RESEARCH	313	870	FINGERMATRIX	290	988	MICROCOMPUTER APPLICATIONS	290
	AT&T	13	1160	FISCHER INTERNATIONAL SYSTEMS	285, 290		MICROSOFT	13, 151, 257
851	ATI TECHNOLOGIES	195	865	FIVESTAR COMPUTERS	181	1131	MICROTOUCH SYSTEMS	65
1008	AZ-TECH SOFTWARE	290	1014	FLINDER SOFTWARE LABORATORIES	290		MOTOROLA	13
				FORTRAN USERS GROUP	13	993	MPPI	290
1149	BISCOM	65	989	FOUNDATIONWARE	290	1080	MULTI-TECH SYSTEMS	162
868	BLACK BOX	290				983	MURATA BUSINESS SYSTEMS	143
878	BORLAND INTERNATIONAL	290	1075	GENERAL DATACOMM	162		NATIONAL BUREAU OF STANDARDS	267
1117	BRIGHTBILL-ROBERTS	80	1140	GENERAL PARAMETRICS	65	1170	NEC HOME ELECTRONICS	313
981	BROOKTROUT TECHNOLOGY	143	1123	GENERIC SOFTWARE	80		NEXT	235
1101	BUMBLEBEE SOFTWARE	80	852	GENOA SYSTEMS	195	1108	NKR RESEARCH	80
			1040	GIBSON RESEARCH	119	1018	NORTH EDGE SOFTWARE	290
1129	C.I.TOH ELECTRONICS	65	1005	GLENCOE ENGINEERING	290	1037	NORTHGATE COMPUTER SYSTEMS	119
M202	CAMBRIDGE DIRECT	241	1041	GOLDEN BOW SYSTEMS	119		OPEN SOFTWARE FOUNDATION	13
1044	CAMBRIDGE NORTH AMERICA	119	1076	GVC-CHENEL	162	853	ORCHID TECHNOLOGY	195, 313
	CARNEGIE-MELLON UNIVERSITY	13		HARRIS SEMICONDUCTOR	13	1171		
984	CASADY & GREENE	290	1003	HAWKEYE GRAFIX	290	1006	PANDA SYSTEMS	290
881	CASEWORKS	205	1077	HAYES MICROCOMPUTER PRODUCTS	162	1172	PARADISE SYSTEMS	313
1144	CBM ELECTRONICS	65	855	HEADLAND TECHNOLOGY	195	1021	PARAGON CONCEPTS	137
1148	CHRONOS SOFTWARE	65	1135	HERCULES COMPUTER TECHNOLOGY	65	1035	PAUL MACE SOFTWARE	119
884	CLARIS	209	1128	HEWLETT-PACKARD	65	1156	PCEASY	290
1164	COLUMBIA DATA PRODUCTS	313	1124	HITECH INTERNATIONAL	65	1116	PEOPLESMITH SOFTWARE	80
862	COMAR SYSTEX	187		HOWARD W. SAMS	51	1136	PERCEPTIVE SOLUTIONS	65
874	COMMAND SOFTWARE SYSTEMS	290		HOWTEK	247	1036	PETER NORTON COMPUTING	119
998	COMMCRYPT	290	1145	IBM	13, 65, 257	996	PICO PUBLISHING	290
	COMMODORE BUSINESS MACHINES	13	1155	IDENTIX	290	1120	PINNACLE PUBLISHING	80
992	COMNETCO	290	1032	IMAGINE THAT	119	1104	POLYTRON	80
1158	COMPUTER INTEGRITY	290	1010	IMANAGE SOFTWARE	290	880	PORAK COMPUTING SERVICES	290
1071	CONCORD DATA SYSTEMS	162	871	INFOSAFE	290	1022	PREFERRED PUBLISHERS	137
1165	CONSENSYS	313		INFOTECH	13	1173	PRIAM	247, 313
1102	COPIA INTERNATIONAL	80	1078	INMAC	162	999	PRIDE SOFTWARE ADVANCEMENT	290
1031	CORE INTERNATIONAL	119, 313	1161	INSET SYSTEMS	290		PRIME COMPUTER	13
1166			1169	INTEL	13, 313	1137	PROHANCE TECHNOLOGIES	65
883	COREL SYSTEMS	213	1138	IOTECH	65	1020	PYRAMID DEVELOPMENT	290
				JOHN WILEY & SONS	51	982	QUADRAM	143
1114	DAC SOFTWARE	80	1013	KENT MARSH LTD.	290	986	QUAID SOFTWARE	290
1072	DATA RACE	162	985	KINETIC	290		RACAL-VADIC	162
1119	DATA TRANSLATION	80	1034	KOLOD RESEARCH	119	1002	RAINBOW TECHNOLOGIES	290
1024	DELL COMPUTER	97	858	KYE INTERNATIONAL	187		RASTER IMAGE PROCESSING SYSTEMS	13
857	DFI	187				1004	RG SOFTWARE SYSTEMS	290
1167	DIGIBOARD	313	987	LARNEN TASAR	290			
1000	DIGITAL DISPATCH	290	1033	LASERGO	119			
	DIGITAL EQUIPMENT	13	872	LATTICE	285, 290			
1026	DIGITAL VISION	97						
882	DIGITALK	201						

INQUIRY #	COMPANY	PAGE
1015	RSA DATA SECURITY	285, 290
	SCRIBNER'S	51
990	SECTOR TECHNOLOGY	290
1016	SECURE TELECOM	290
1012	SECURITY MICROSYSTEMS CONSULTANTS	290
1042	SHARP ELECTRONICS	119
M200	SILICON BEACH SOFTWARE	219
860	SKYWORLD TECHNOLOGY	187
879	SOFTGUARD SYSTEMS	290
877	SOFTWARE DIRECTIONS	290
1157	SOFTWARE MASTERS	290
	SONY	13
869	SOPHCO	290
854	STB SYSTEMS	195
1039	STORAGE DIMENSIONS	119
1112	STRUCTURAL RESEARCH AND ANALYSIS	80
	SUN MICROSYSTEMS	13
876	SUPERMAC TECHNOLOGY	290
1111	SWANSON ANALYSIS	80
1130	SYSGEN	65
1023	T/MAKER	137
864	TANDON	181
1011	TECHNICAL COMMUNICATION	290
1175	TECMAR	313
1082	TELCOR SYSTEMS	162
	TELEBIT	321
1083	TELENETICS	162
875	THE CODER'S SOURCE	290
856	THE COMPLETE PC	187
1174	THE SANTA CRUZ OPERATION	313
1152	THOMAS-CONRAD	65
1019	THUMBS CAN	290
1125	TOSHIBA AMERICA	13, 65
1043	TRAVELING SOFTWARE	119
1001	TRIGRAM SYSTEMS	290
1085	USROBOTICS	162
1127	UNISYS	65
995	UNITED SOFTWARE SECURITY	290
1084	UNIVERSAL DATA SYSTEMS	162
1139	UNIVERSAL VECTORS	65
1086	VEN-TEL	162
M201	VPL RESEARCH	219
	W. H. FREEMAN	51
1029	WARD SYSTEMS GROUP	97
1087	WESTERN DATACOMM	162
1176	WESTERN DIGITAL	65, 313
1151		
1177	WESTERN DIGITAL IMAGING	313
1199	WILLOW PERIPHERALS	65
1009	WISDOM SOFTWARE	285, 290
1159	WORLDWIDE DATA	290
1134	YARC SYSTEMS	65
	ZENITH DATA SYSTEMS	51

COMING UP IN BYTE

PRODUCTS IN PERSPECTIVE:

The front of BYTE will feature, as always, Microbytes, What's New, and Short Takes. July's Short Takes, BYTE's hands-on look at new and interesting products in an abbreviated format, will include Hewlett-Packard's DeskJet Plus; PixelPaint 2.0 from SuperMac Technology; HyperPAD, an IBM PC desktop manager from Brightbill-Roberts; the Mitsubishi Smart Mouse; an add-in security-card device called Counterpart from Fifth Generation Systems; and Culture 1.0, a Macintosh program from Cultural Resources with a unique perspective on Western civilization.

Our **First Impression** for July will feature Apple's Color QuickDraw, an upgrade to the Macintosh II family's core graphics primitives that significantly expands their capabilities while retaining compatibility to existing Mac applications.

The **Product Focus** will cover five of the most popular file-server-oriented LAN operating systems.

One scheduled **system review** will look at the IBM PS/2 Model 70. Another one will be on the NCR PC916sx, the company's entry into the curious 16-bit 80386SX field.

Our **hardware reviews** are set to include the Tektronix Phaser CP, a new low-cost entry in the PostScript-compatible color thermal-transfer printer field. Additionally, we plan to look at the Elite 16 Plus HyperCache, an EMS 4.0 board from Profit Systems with an on-board 16K- or 32K-byte memory cache that gives it a performance edge.

For **software reviews**, we have on tap Phar Lap Software's 386|VMM. An extended DOS environment puts the 80386 CPU into flat memory mode; that is, it uses the 32-bit capabilities of the 80386 chip to address large amounts of memory. We also hope to include Ithaca Software's HOOPS (Hierarchical Object-Oriented Picture System), a library that provides support for three-dimensional imaging to C or FORTRAN programs.

In the **application reviews** section, we'll look at Folio Views from Folio Corp., a synthesis of several applications for DOS machines: text retrieval, hypertext linking, word processing, directory management, and electronic publishing. Another article will examine the much-ballyhooed WingZ, a spreadsheet for the Macintosh that also provides flexible, presentation-quality charts based on your worksheets.

IN DEPTH:

The July subject will be **distributed processing**. In it, we'll focus on the state of the art with articles on such topics as remote procedure calls, the benefits of transparency in distributed systems, and distributed personal-computer-based document image processing.

FEATURES:

In addition to our **Hands On** and **Expert Advice** columns—Under the Hood, Some Assembly Required, Computing at Chaos Manor, Down to Business, Macinations, Applications Plus, and OS/2 Notebook—we'll have a new Expert Advice column on communications, Net/Works.

READER SERVICE

To get further information on the products advertised in BYTE, fill out the reader service card by circling the numbers on the card that correspond to the inquiry number listed with the advertiser. This index is provided as an additional service by the publisher, who assumes no liability for errors or omissions.

* Correspond directly with company.

Alphabetical Index to Advertisers

Inquiry No.	Page No.	Inquiry No.	Page No.	Inquiry No.	Page No.	Inquiry No.	Page No.	
8	2001 SALES	38	316	DATA PRO	237	161	MAP INFO	61
9	2001 SALES	38	79	DATA TRANSLATION	59	162	MARYMAC INDUSTRIES	364
M3	ADVANCED GRAVIS C.T.	250	80	DATAQ	40	163	MATHSOFT	67
M4	ADVANCED GRAVIS C.T.	250	82	DELL COMPUTER	CII,1	164	MATHSOFT	67
16	ADVANCED LOGIC RESEARCH	2		* DELL COMPUTER	204A-B	306	MATRIX SOFTWARE	302
17	ADVANCED LOGIC RESEARCH	3	84	DELTA COMPUTING TECH	361	166	MAXON	117
318	ADVANCED MATRIX TECH	320	85	DIGITAL RESEARCH	108	314	MCGRW HILL COLLEGE DIV.	50
10	ADVANCED MICRO DEVICES	276	M32	DIGITALK	251	167	MEAD COMPUTER	358
11	ADVANTAGE SOFTWARE	211	86	DIGI-DATA	354	168	MEDIA CYBERNETICS	266
12	AGRANAT SYSTEMS	46	87	DISKOTECH	360	169	MEDIA CYBERNETICS	266
13	AK SYSTEMS	362	88	DISKETTE CONNECTION	359	170	MEGASOFT	354
14	ALADDIN KNOWLEDGE SYS.	306	89	DISKS AND LABELS TO GO	364	171	MEGATEL COMPUTER	60
15	ALPHA PRODUCTS	365	90	DIVERSIFIED COMPUTERS	364	172	MERRITT COMPUTERS	319
19	AMERICAN SMALL BUS COMP.	142	M8	DOUGLAS ELECTRONICS	248	173	METRABYTE	359
* AMPRO	207	91	DYNAMIC ELECTRONICS	370	174	MICRO SECURITY SYS.	256	
20	AMS	370	92	ECOSOFT	58	175	MICRO SECURITY SYS.	256
21	ANNABOOKS	349	93	ELECTRONIC ENERGY CNTRL	354	176	MICRO TELESIS	140
22	APPLIED PROGRESSIVE ELEC	372,373	94	ELEXOR INC.	354	177	MICROCOM	186
23	ASHTON-TATE	30	95	EMERSON ELECTRIC	96	* MICROCOMPUTER MKTG. CNCL	307	
24	ASHTON-TATE	30	327	EVEREX SYS. COMP. DIV.	26,27	M1	MICROGROUP	224
25	AST RESEARCH	15	328	EVEREX SYS. COMP. DIV.	26,27	M2	MICROGROUP	224
26	AST RESEARCH	15	329	EXECUTIVE PHOTO & SUPPLY	136	178	MICROLINEAR CONTROLS	355
27	ATI TECHNOLOGIES	141	245	FASTLYNX/RUPP	335	179	MICROLINEAR CONTROLS	355
28	ATRON	64	96	FLAGSTAFF ENGINEERING	118	180	MICROPROCESSORS UNLTD.	359
M30	AUTODESK INC.	238,239	97	FLAGSTAFF ENGINEERING	118	M14	MICROSIM CORP.	218
29	A.C.P.	371	98	FLAGSTAFF ENGINEERING	118	M15	MICROSIM CORP.	218
30	A.N. WHOLESALE & RETAIL	360	99	FLAGSTAFF ENGINEERING	118	181	MICROTECH CONVERSION SYS.	356
33	B & B ELECTRONICS	354		* FORD (SIMULATOR)	48A-B	182	MICROWAY	150
35	B & C MICRO	363	103	FORTRON	173		MICROWAY	309
36	B & C MICRO	363	104	FORTRON	173	183	MIDI MUSIC	363
37	BARCODE INDUSTRIES	94	105	FOX SOFTWARE	23	184	MITSUBISHI	126,127
38	BAYTECH	43	106	FTG DATA SYSTEMS	364	185	MITSUBISHI	126,127
39	BAYTECH	43	109	GATEWAY 2000	10,11	188	MIX SOFTWARE	329
31	BE AWARE, INC.	104	111	GENERAL DATA COMM.	185	189	MKS	215
32	BE AWARE, INC.	104	110	GENERAL ELECTRIC (GEISCO)	33		* MONTGOMERY GRANT	261
40	BEST COMPUTER	284	M9	GENERAL PARAMETRICS CORP.	240		* MOTOROLA INC.	221
41	BEST COMPUTER	284	112	GENERIC SOFTWARE	101	190	MULTITECH SYSTEMS	179
42	BINARY ENGINEERING	28	113	GENERIC SOFTWARE	101	191	MULTITECH SYSTEMS	179
	BINARY TECH	360	114	GENESIS DATA SYSTEMS	86	192	NANAO	208
44	BINARY TECH	360	115	GENESIS DATA SYSTEMS	86	193	NANAO	208
* BIX	252B		116	GENICOM	282,283	322	NATIONAL INSTRUMENTS	CIII
450	BIX	310,311	317	GENOA	87	323	NATIONAL INSTRUMENTS	CIII
* BIX	326		118	GOLDEN BOW	42	195	NATURAL MICROSYS	216
46	BLAISE COMPUTING INC.	49	119	GOLDEN BOW	42		* NEC HOME	36,37
47	BOLT SYSTEMS	154	120	G-TEK INC.	124		* NEC HOME	246,247
48	BORLAND	69	121	G-TEK INC.	124	196	NEW GENERATION SYSTEMS	370
49	BORLAND	69	122	HAMMERLY COMPUTER SERV.	31	M16	NICUS	236
50	BP MICRO SYSTEMS	370	M10	HAYES MICROCOMPUTER	222,223	M17	NICUS	236
* BUYERS MART	338-348		123	HEWLETT PACKARD COMP.	18,19	199	NOHAU	356
* BYTE BACK ISSUE	357		124	HEWLETT PACKARD PERIPHERAL	148,149	200	NORTON-LAMBERT	21
320	BYTE BITS	356	125	HIGH RESOLUTION TECH.	360	201	OKIDATA	315
* BYTE BOOK CLUB	192,193		126	HI-Q INTERNATIONAL INC.	104	202	ON-TARGET ASSOCIATES	361
* BYTE PUBLICATION	300,301		127	HI-TECH EQUIPMENT CORP.	361		* ORACLE	85
* BYTE PUBLICATION	312		130	HOOLEON	22	203	OVERLAND DATA	364
* BYTE SUB. MESSAGE	120		131	HOOLEON	22	204	PACIFIC COMPUTER	355
* BYTE SUB. SERVICE	332,349		132	HOUSTON INSTRUMENT	39	205	PACIFIC COMPUTER	355
51	BYTEK	360	133	I C EXPRESS	362	206	PARA SYSTEMS	47
* BYTEWEEK/NEWSLETTER	253		137	I O TECH	362	M18	PARAGON CONCEPTS, INC.	227
52	C W DATA-LABS	364		* IBM	203	207	PATTON & PATTON	130
53	CAD WAREHOUSE	138	M11	IMAGINE THAT!	228		* PC EXPO	292,293
54	CAL COMP	212		* INECTRA, INC.	356	208	PERISCOPE	159
55	CAL COMP	212	134	INTEGRAND	112	209	PERISCOPE	159
* CALIFORNIA DIGITAL	369		135	INTERACTIVE SYSTEMS	9	210	PERSONAL TEX	160
56	CAMBRIDGE N.A.	131	136	INTERACTIVE SYSTEMS	9	211	PHAR LAP SOFTWARE	48
57	CANON	103	M12	IO TECH	230	220	PI COMPUTER CORP.	166
59	CAPITAL EQUIPMENT	129	138	JAMECO	352,353	221	PI COMPUTER CORP.	166
* CCM/MCGRAW HILL	271		139	JENSEN & PARTNERS	133	M19	PMC TELESYSTEMS INC.	231
* CLARIS SOFTWARE	232,233		6	J.D.R.	374-377	212	POCKETSOFT	174
* CLEO SOFTWARE	52		7	J.D.R.	374-377	M20	PRECISION DATA PROD.	220
303	CLONE COMPUTERS	350,351	140	KADAK	367	213	PRECISION PLUS	60
* COMPACT DISK PRODUCTS	54		141	KEA SYSTEMS	363	214	PROGRAMMERS PARADISE	62,63
* COMPAQ	70,71		142	KEA SYSTEMS	363	215	PROGRAMMER'S SHOP	122
61	COMPUCALCLASSICS	145	143	KNOWLEDGE GARDEN	252C	216	PROTECH MARKETING	56
62	COMPUCOM	349	144	KORE INC.	362	217	PROTEUS TECHNOLOGY CORP.	29
63	COMPUSAVE	357	145	KYE INT'L	180	218	PROXIMITY	46
64	COMPUTER ASSOCIATES	76,77	146	KYE INT'L	180	219	PROXIMITY	46
65	COMPUTER BOOK CLUB	113	149	LAHEY COMPUTER SYSTEMS	276	223	QUA TECH	370
67	COMPUTER FRIENDS	362	M31	LANGUAGE SYSTEMS	231	224	QUA TECH	370
68	COMPUTER MAIL ORDER	106,107	M33	LASER CONNECTION	252A	227	QUALSTAR	361
69	COMPUTER SYSTEMS RES.	44,45	151	LINK COMPUTER GRAPHICS	363	228	QUANTUM SOFTWARE	79
70	COMPUTERLANE	194	152	LINK COMPUTER GRAPHICS	363	234	QUARTERDECK	134,135
71	COMPUTERTRADER	102	153	LOGICAL DEVICES	354	235	QUARTERDECK	134,135
M7	CONNECTIX	244	154	LOGICAL DEVICES	354	236	QUARTERDECK	134,135
72	CONTECH	361	155	LOGICAL DEVICES	354	237	QUARTERDECK	134,135
73	CONTROL VISION	370	156	LOGICAL DEVICES	354	321	QUAY COMP. CORP.	326
74	CORECO, INC.	32	157	LOGITECH	73	232	RADIO SHACK	CIV
75	CORPORATE COMPUTERS OF IOWA	57	158	LOGITECH	73		* RAIMA	51
76	CORPORATE COMPUTERS OF IOWA	57	159	LOGITECH	73	239	RAINBOW TECH.	263
77	COVOX	356	160	LOGITECH	75	240	RAINBOW TECH.	263
319	CUBIX CORP.	333		* MACMILLAN BOOK CLUBS INC.	25	304	RAINBOW TECH.	317
* CURTIS, INC.	362		311	MANNESMANN TALLY	281	305	RAINBOW TECH.	317
* DAMARK	152		312	MANNESMANN TALLY	281	241	REAL TIME DEVICES	370
242	REFERENCE SOFTWARE	169	243	ROSE ELECTRONICS	161	244	RUPP CORPORATION	75
244	RUPP CORPORATION	75	324	RUPP CORPORATION	75	246	SABINA INT'L	354
247	SAFEWARE	361	248	SAIC	56	249	SAMNA	155
250	SANTA CRUZ OPERATION	81	251	SCHWAB	356	252	SCIENTIFIC ENDEAVORS CORP.	362
253	SCIO COMPUTERS	370	* SEAGATE	216B		M21	SHREVE SYSTEMS	236
* SOFTWARE DEV. SYS.	99		309	SOFTWARE LINK	92,93	310	SOFTWARE LINK	92,93
256	SOFTWARE SECURITY	41	257	SOTA TECHNOLOGY	17	M22	SPECTRA BLUE	252
258	SPECTRUM	35	259	STATSOFT	121	260	STSC	265
261	SUMMAGRAPHICS	91	262	SUMMAGRAPHICS	91	263	SUPERSOFT	84
264	SURAH	361	* SWIRL SOFT	356		325	S-100	368
326	S-100	368	265	SN'W ELECTRONICS	204	266	TALKING TECHNOLOGY	364
267	TATUNG	200	268	TECHNOLOGY RESOURCE	178	269	TECHNOLOGY RESOURCE	178
270	TELCOR	260	271	TELEBIT	171	272	TELEBYTE TECHNOLOGY, INC.	54
273	TIMELINE	367	274	TMI	86	275	TOSHIBA	82,83
276	TOSHIBA	82,83	277	TOUCHBASE SYSTEMS	20	278	TRAVELING SOFTWARE	153
279	TRUE DATA	279	280	TRUIVISION	245	281	TWINCOM	272,273
282	UNITEK	366	283	U.S. ROBOTICS	55	284	VAMP, INC.	234
283	U.S. ROBOTICS	55	285	VENTURA PERIPHERALS	349	286	VERBATIM CORPORATION	123
M23	VAMP, INC.	234	* VERMONT CREATIVE	12		M24	VERSACAD	229
287	VNS AMERICA	274	M25	VERSACAD	229	288	VICTORY ENTERPRISES	122
288	VNS AMERICA	325	289	WAREHOUSE DATA	125	289	WAREHOUSE DATA	125
307	WELLS AMERICAN	105	291	WELTEK	30	292	WELTEK	30
308	WELLS AMERICAN	105	293	WESTERN CONTAINER & CASE	363	M26	WHITE PINE SOFTWARE	220
292	WELTEK	30	294	WIESEMANN & THEIS GMBH	176	295	WINTEK CORP.	359
293	WESTERN CONTAINER & CASE	363	296	WINTEK CORP.	359	M27	X TREE COMPANY	243
M26	WHITE PINE SOFTWARE	220	297	XELTEK	354	298	XENTEK	360
294	WIESEMANN & THEIS GMBH	176	299	Z-WORLD	359	300	Z-WORLD	359
295	WINTEK CORP.	359	301	ZEOS INTERNATIONAL	88,89	315	ZERICON	154
296	WINTEK CORP.	359	302	ZORTECH	156			
M27	X TREE COMPANY	243						
297	XELTEK	354						
298	XENTEK	360						
299	Z-WORLD	359						
300	Z-WORLD	359						
301	ZEOS INTERNATIONAL	88,89						
315	ZERICON	154						
302	ZORTECH	156						

INTERNATIONAL SECTION 96 IS 1-64
No North American Inquiries please.

401	ADDISON-WESLEY	96IS-24
402	AMDS	96IS-12
	* BIX	96IS-42
403	BIX	96IS-63
404	BLUE CHIP TECHNOLOGY	96IS-36
	* BYTE BACK ISSUES	96IS-50
448	BYTE BITS	96IS-40
	* BYTE INTERNATIONAL	96IS-64
	* BYTE INT'L POSTCARD	96IS-34
	* BYTE PUBLICATIONS	96IS-32
	* BYTEWEEK/NEWSLETTER	96IS-48

READER SERVICE

Inquiry No.	Page No.	Inquiry No.	Page No.	Inquiry No.	Page No.	Inquiry No.	Page No.
* BYTE SUB. SERVICE	96IS-60	439 SIEMENS	96IS-57	533 NVIEW	MW-3	Pacific Coast	96 PC 1-16
405 COMMUNICATION RESEARCH	96IS-35	* SOFTLINE CORPORATION	96IS-19	534 UNDERWARE ELECTRONICS	MW-11	541 4 GUYS COMPUTERS	PC-14
406 COPAM	96IS-27	440 SOFTWARE CONSTRUCTION	96IS-49	535 Y.E.S. MULTINATIONAL, INC.	MW-5	* BYTEWEEK/NEWSLETTER	PC-12
* COMP. FOR THE BLIND	96IS-22	441 SUN MICROSYSTEMS	96IS-51	536 Y.E.S. MULTINATIONAL, INC.	MW-5	542 DIGI-FONTS	PC-1
449 DATA PRO	96IS-29	442 TRIANGLE DIGITAL	96IS-38			543 EDIMAX COMPUTER CO.	PC-6
408 DATEX	96IS-23	443 USA SOFTWARE	96IS-13			544 EDIMAX COMPUTER CO.	PC-6
409 ELECTRONIC EQUIPMENT	96IS-44	446 U.S. MICRO ENGINEERING	96IS-18			545 E-TECH RESEARCH, INC.	PC-12
* ELONEX	96IS-59	447 U.S. MICRO ENGINEERING	96IS-18			546 FINALSOFT CORP.	PC-9
410 FAST ELECTRONIK	96IS-33	444 VCH-VERLAG	96IS-38			547 FINALSOFT CORP.	PC-9
445 GAMMA PRODUCTIONS	96IS-28					548 HALSKAR SYSTEMS	PC-7
411 GIGA	96IS-30					549 HALSKAR SYSTEMS	PC-7
412 GREY MATTER	96IS-61					550 JB TECHNOLOGIES	PC-11
413 GTCO	96IS-45					551 KORTEK INC.	PC-3
414 HAUPPAUGE COMPUTER	96IS-2					552 MELBOURNE HOUSE	PC-5
415 HWA HSIN	96IS-26					553 MEXTEL	PC-4
416 ICC	96IS-43					554 MICRO UNIVERSE	PC-6
419 INES	96IS-30					555 MIRACLE COMP.	PC-2
420 INTERQUADRAM	96IS-5					556 OSMOS INC.	PC-14
421 INTERQUADRAM	96IS-7					557 OSMOS INC.	PC-14
422 INTERQUADRAM	96IS-9					560 TELETEK	PC-13
423 IX I	96IS-40					561 TELETEK	PC-13
424 KAP	96IS-15					562 USM DISTRIBUTORS	PC-15
425 MASHOW SOFTWARE EXP	96IS-47					563 USM DISTRIBUTORS	PC-15
426 MAYFAIR MICROS	96IS-37						
427 MICROMINT/JB DESIGNS	96IS-20						
428 MICRON INC.	96IS-31						
429 MICROPHAR	96IS-16						
430 NOKIA	96IS-41						
431 NOVELL	96IS-39						
432 PACIFIC DATA	96IS-55						
433 PACIFIC DATA	96IS-55						
434 PAFEC LTD.	96IS-25						
435 PERICOM	96IS-17						
436 PHILIPS INDUSTRIAL AUTOMATION SYSTEMS	96IS-11						
437 PHILIPS L.C.D. MONITORS	96IS-21						
438 Q.T. SOFTWARE	96IS-36						
* SCANDEC TRIBUTOR USA	96IS-14						

INT'L DIRECT RESPONSE POSTCARDS

* ADDISON-WESLEY	96IS
* C-USERS JOURNAL	96IS
* DISK STAR	96IS
* HAMMERLY COMPUTER	96IS
* LANGUAGE TECH	96IS
* METRA BYTE	96IS
* MICHLIN COMPUTER	96IS
* REASONABLE SOLUTIONS	96IS
* SOFTWARE EXCITEMENT	96IS
* TOUCH BASE SYSTEMS	96IS
* T.S.A. CORP.	96IS
* US/PD LIBRARY	96IS

REGIONAL SECTIONS

Midwest	96 MW 1-12
* BYTEWEEK/NEWSLETTER	MW-4
526 CONTINENTAL TRADING	MW-6,7
527 CONTINENTAL TRADING	MW-6,7
528 HARD DRIVES INT'L	MW-1
529 HARD DRIVES INT'L	MW-1
530 ISD COMPANY	MW-9
531 ISD COMPANY	MW-9
532 MEXTEL	MW-2

Inquiry No.	Page No.	Inquiry No.	Page No.	Inquiry No.	Page No.
476 COMMUNICATION RES. GRP.	M/AT-1	501 AKER CORP	NE-8	486 4 GUYS COMPUTERS	SO-7
477 COMMUNICATION RES. GRP.	M/AT-1	502 AKER CORP	NE-8	487 COMTEQ COMPUTER CORP.	SO-4
478 EXPERT SYS. INTEGRATORS	M/AT-2	* BYTEWEEK/NEWSLETTER	NE-6	488 COMTEQ COMPUTER CORP.	SO-4
479 OWL COMPUTERS	M/AT-4	503 COMMUNICATION RES. GRP.	NE-11	489 FINALSOFT CORP.	SO-3
480 OWL COMPUTERS	M/AT-4	504 COMMUNICATION RES. GRP.	NE-11	490 FINALSOFT CORP.	SO-3
481 WEDGE TECHNOLOGIES	M/AT-3	505 DATAWARE PRODUCTS, INC.	NE-9	491 HARD DRIVES INT'L	SO-1
		506 DATAWARE PRODUCTS, INC.	NE-9	492 HARD DRIVES INT'L	SO-1
		507 DIRECT OF NEW ENGLAND	NE-6	493 SQUARE FIELD CORP.	SO-2
		508 EDIMAX COMPUTER CO.	NE-4	494 SQUARE FIELD CORP.	SO-2
		509 EDIMAX COMPUTER CO.	NE-4	495 UNDERWARE ELECTRONICS SO-5	
		510 ELECTRIFIED DISCOUNTERS	NE-1		
		511 MANCHESTER EQUIPMENT	NE-10		
		512 PATRIOT COMPUTERS	NE-2		
		513 PC LINK	NE-5		
		514 TDX PERIPHERALS	NE-7		
		515 TDX PERIPHERALS	NE-7		
		516 TELETEK	NE-3		
		517 TELETEK	NE-3		

BYTE ADVERTISING SALES STAFF:

Steven M. Vito, Associate Publisher/V.P. of Marketing, One Phoenix Mill Lane, Peterborough, NH 03458, tel. (603) 924-9281
 Arthur Kossack, Eastern Regional Sales Manager, 645 North Michigan Ave., Chicago, IL 60611, tel. (312) 751-3700
 Jennifer L. Bartel, Western Regional Sales Manager, 8111 LBJ Freeway, Suite 1350, Dallas, TX 75251, tel. (214) 644-1111
 L. Bradley Browne, Telemarketing Director, One Phoenix Mill Lane, Peterborough, NH 03458, tel. (603) 924-9281

NEW ENGLAND
 ME, NH, VT, MA, RI, ONTARIO
 CANADA & EASTERN CANADA
 John C. Moon (617) 262-1160
 McGraw-Hill Publications
 575 Boylston Street
 Boston, MA 02116

ATLANTIC
 NY, NJ, CT, NJ (NORTH)
 Ken Tashy (212) 512-2645
 McGraw-Hill Publications
 1221 Avenue of the Americas—
 36th Floor
 New York, NY 10020

EAST
 PA, NJ (SOUTH),
 MD, W. VA, DE, D.C.
 Thomas J. Brun (215) 496-3833
 McGraw-Hill Publications
 Three Parkway
 Philadelphia, PA 19102

SOUTHEAST
 NC, SC, GA, FL, AL, TN, VA, MS
 Thomas Tolbert (404) 252-0626
 McGraw-Hill Publications
 4170 Ashford-Dunwoody Road
 Suite 420
 Atlanta, GA 30319

MIDWEST
 IL, MO, KS, IA, ND, SD, MN,
 KY, OH, WI, NB, IN, MI
 Kurt Kelley (312) 751-3740
 McGraw-Hill Publications
 Blair Building
 645 North Michigan Ave.
 Chicago, IL 60611

**SOUTHWEST,
 ROCKY MOUNTAIN**
 CO, WY, OK, TX, AR, LA
 Carl Heinrich (713) 462-0757
 McGraw-Hill Publications
 7600 W. Tidwell Rd.—Suite 500
 Houston, TX 77040

SOUTH PACIFIC
 SOUTHERN CA, AZ, NV,
 LAS VEGAS
 Ron Cordek (714) 557-6292
 McGraw-Hill Publications
 3001 Red Hill Ave.
 Building #1—Suite 222
 Costa Mesa, CA 92626

Tom Harvey (213) 480-5243
 McGraw-Hill Publications
 3333 Wilshire Boulevard #407
 Los Angeles, CA 90010

NORTH PACIFIC
 HI, WA, OR, ID, MT,
 NORTHERN CA,
 NV (except LAS VEGAS),
 W. CANADA, UT
 Christine Kopec (415) 362-4600
 McGraw-Hill Publications
 425 Battery Street
 San Francisco, CA 94111

Bill McAfee (408) 879-0371
 McGraw-Hill Publications
 1999 South Bascom Ave.
 Suite #210
 Campbell, CA 95008

BYTE BITS (2x3)
 Mark Stone (603) 924-6830
 BYTE Publications
 One Phoenix Mill Lane
 Peterborough, NH 03458

The Buyer's Mart (1x2)
 Brian Higgins (603) 924-3754
 BYTE Publications
 One Phoenix Mill Lane
 Peterborough, NH 03458

Regional Advertising
 Scott Gagnon (603) 924-4380
 BYTE Publications
 One Phoenix Mill Lane
 Peterborough, NH 03458

Larry Levine (603) 924-4379
 BYTE Publications
 One Phoenix Mill Lane
 Peterborough, NH 03458

Barry Echavarria (603) 924-2574
 BYTE Publications
 One Phoenix Mill Lane
 Peterborough, NH 03458

National Sales
 Liz Coymann (603) 924-2518
 Dan Harper (603) 924-2598
 Elisa Lister (603) 924-2665
 BYTE Publications
 One Phoenix Mill Lane
 Peterborough, NH 03458

BYTE Deck Mailings
 Ed Ware (603) 924-6166
 BYTE Publications
 One Phoenix Mill Lane
 Peterborough, NH 03458

**A/E/C Computing Deck
 Computing for Engineers**
 Mary Ann Goulding
 (603) 924-2664
 BYTE Publications
 One Phoenix Mill Lane
 Peterborough, NH 03458

International Advertising Sales Staff:

Frank Tanis, European Sales Manager, BYTE Publications,
 Batenburg 103, 3437 AB Nieuwegein, The Netherlands, tel: 31 34 02 49496, fax: 31 34 02 37944

Karen Lennie
 McGraw-Hill Publishing Co.
 34 Dover St.
 London W1X 4BR
 England 01 493 1451

Ros Weyman
 Serving Germany, Austria, & Switzerland
 McGraw-Hill Publishing Co.
 34 Dover St.
 London W1X 4BR
 England 01 493 1451

Mr. Hans Csokor
 Publimedia
 Reinsnerstrasse 61
 A-1037 Vienna, Austria
 222 75 76 84

Yvonne Rosenblum
 International Communications
 43 Brodetsky St.
 Ramat Aviv 69052
 Israel 972 3 5434808

Mrs. Maria Sarmiento
 Pedro Teixeira 8, Off. 320
 Iberia Mart I
 Madrid 4, Spain
 1 45 52 891

Alessandro Coari
 McGraw-Hill Publishing Co.
 Via Flavio Baracchini 1
 20123 Milan, Italy
 (2) 89010103

Seavex Ltd.
 400 Orchard Road, #10-01
 Singapore 0923
 Republic of Singapore
 Tel: 734-9790
 Telex: RS35539 SEAVEX

Seavex Ltd.
 503 Wilson House
 19-27 Wyndham St.
 Central, Hong Kong
 Tel: 5-260149
 Telex: 60904 SEVEX HX

Masaki Mori
 McGraw-Hill Publishing Co.
 Overseas Corp.
 Room 1528
 Kasumigaseki Bldg.
 3-2-5 Kasumigaseki,
 Chiyoda-Ku
 Tokyo 100, Japan
 3 581 9811

Mr. Ernest McCrary
 Empresa Internacional de
 Comunicacoes Ltda.
 Rua da Consolacao, 222
 Conjunto 103
 01302 Sao Paulo, S.P., Brasil
 Tel: (11) 259-3811
 Telex: (100) 32122 EMBN

READER SERVICE

To get further information on the products advertised in BYTE, fill out the reader service card by circling the numbers on the card that correspond to the inquiry number listed with the advertiser. This index is provided as an additional service by the publisher, who assumes no liability for errors or omissions.

* Correspond directly with company.

Index to Advertisers by Product Category

Inquiry No.	Page No.	Inquiry No.	Page No.	Inquiry No.	Page No.	Inquiry No.	Page No.
HARDWARE							
800	ADD INS						
15	ALPHA PRODUCTS	365					
402	AMDS	96IS-12					
27	ATI TECHNOLOGIES	141					
33	B & B ELECTRONICS	354					
35	B & C MICRO	363					
36	B & C MICRO	363					
404	BLUE CHIP TECHNOLOGY	96IS-36					
59	CAPITAL EQUIPMENT	128					
60	CAPITAL EQUIPMENT	129					
73	CONTROL VISION	370					
77	COVOX	356					
319	CUBIX CORP.	333					
78	CURTIS, INC.	362					
79	DATA TRANSLATION	59					
84	DELTA COMPUTING TECH	361					
445	GAMMA PRODUCTIONS	96IS-28					
317	GENOA	87					
120	G-TEK INC.	124					
121	G-TEK INC.	124					
125	HIGH RESOLUTION TECH.	360					
137	IO TECH	362					
419	INES	96IS-30					
420	INTERQUADRAM	96IS-5					
421	INTERQUADRAM	96IS-7					
422	INTERQUADRAM	96IS-9					
M12	IO TECH	230					
424	KAP	96IS-15					
141	KEA SYSTEMS	363					
166	MAXON	117					
428	MICRON INC.	96IS-31					
183	MIDI MUSIC	363					
208	PERISCOPE	159					
209	PERISCOPE	159					
436	PHILIPS INDUSTRIAL AUTOMATION SYSTEMS	96IS-11					
220	PI COMPUTER CORP.	166					
221	PI COMPUTER CORP.	166					
223	QUA TECH	370					
224	QUA TECH	370					
241	REAL TIME DEVICES	370					
244	RUPP CORPORATION	75					
324	RUPP CORPORATION	75					
257	SOTA TECHNOLOGY	17					
272	TELEBYTE TECHNOLOGY, INC.	54					
516	TELETEK	96NE-3					
517	TELETEK	96NE-3					
560	TELETEK	96PC-13					
561	TELETEK	96PC-13					
280	TRUEVISION	245					
801	HARDWARE PROGRAMMERS						
35	B & C MICRO	363					
36	B & C MICRO	363					
50	BP MICROSYSTEMS	370					
51	BYTEK	360					
144	KORE INC.	362					
152	LINK COMPUTER GRAPHICS	363					
153	LOGICAL DEVICES	354					
154	LOGICAL DEVICES	354					
155	LOGICAL DEVICES	354					
156	LOGICAL DEVICES	354					
178	MICROLINEAR CONTROLS	355					
179	MICROLINEAR CONTROLS	355					
199	NOHAU	356					
297	XELTEK	354					
300	Z-WORLD	359					
802	INSTRUMENTATION						
80	DATAQ	40					
93	ELECTRONIC ENERGY CTRL.	354					
94	ELEXOR INC.	354					
151	LINK COMPUTER GRAPHICS	363					
173	METRABYTE	359					
274	TMI	86					
803	KEYBOARDS/MICE						
M3	ADVANCED GRAVIS C.T.	250					
M4	ADVANCED GRAVIS C.T.	250					
54	CAL COMP	212					
55	CAL COMP	212					
413	GTCC	96IS-45					
130	HOOLEON	22					
131	HOOLEON	22					
159	LOGITECH	95					
160	LOGITECH	95					
532	MEXTEL	96MW-2					
553	MEXTEL	96PC-4					
261	SUMMAGRAPHS	91					
262	SUMMAGRAPHS	91					
804	MASS STORAGE						
13	AK SYSTEMS	362					
72	CONTECH	361					
86	DIGI-DATA	354					
181	MICROTECH CONVERSION SYS.	356					
203	OVERLAND DATA	364					
227	QUALSTAR	361					
245	RUPP CORPORATION	335					
514	TDX PERIPHERALS	96NE-7					
515	TDX PERIPHERALS	96NE-7					
281	TWINCOM	272,273					
284	VENTURA PERIPHERALS	349					
285	VERBATIM CORPORATION	123					
*	MISCELLANEOUS						
37	BARCODE INDUSTRIES	94					
38	BAYTECH	43					
39	BAYTECH	43					
316	DATA PRO	237					
M9	GENERAL PARAMETRICS CORP.	240					
*	INTECTRA, INC.	356					
134	INTEGRAND	112					
*	MOTOROLA INC.	221					
533	NVIEW	96MW-3					
286	VICTORY ENTERPRISES	122					
805	MODEMS/MULTIPLEXORS						
62	COMPUCOM	349					
545	E-TECH RESEARCH, INC.	96PC-12					
111	GENERAL DATA COMM	185					
177	MICROCOM	186					
190	MULTITECH SYSTEMS	179					
191	MULTITECH SYSTEMS	179					
430	NOKIA	96IS-41					
201	OKIDATA	315					
556	OSMOS INC.	96PC-14					
557	OSMOS INC.	96PC-14					
321	QUAY COMP. CORP.	326					
270	TELCOR	260					
271	TELEBIT	171					
277	TOUCHBASE SYSTEMS	20					
283	U.S. ROBOTICS	55					
806	MONITORS						
192	NANAO	208					
193	NANAO	208					
*	NEC HOME	36,37					
*	NEC HOME	246,247					
437	PHILIPS L.C.D. MONITORS	96IS-21					
267	TATUNG	200					
807	NETWORK HARDWARE						
319	CUBIX CORP.	333					
408	DATEX	96IS-23					
243	ROSE ELECTRONICS	161					
290	WIESEMANN & THEIS GMBH	176					
808	POWER SUPPLIES						
95	EMERSON ELECTRIC	96					
206	PARA SYSTEMS	47					
809	PRINTERS/PLOTTERS						
318	ADVANCED MATRIX TECH	320					
57	CANON	103					
505	DATAWARE PRODUCTS, INC.	96NE-9					
506	DATAWARE PRODUCTS, INC.	96NE-9					
116	GENICOM	282,283					
124	HEWLETT PACKARD PERIPHERAL	148,149					
132	HOUSTON INSTRUMENT	39					
311	MANNESMANN TALLY	281					
312	MANNESMANN TALLY	281					
432	PACIFIC DATA	96IS-55					
433	PACIFIC DATA	96IS-55					
315	ZERICON	154					
810	PRINTER RIBBONS						
67	COMPUTER FRIENDS	362					
811	SCANNERS/DIGITIZERS						
74	CORECO, INC.	32					
96	FLAGSTAFF ENGINEERING	118					
97	FLAGSTAFF ENGINEERING	118					
98	FLAGSTAFF ENGINEERING	118					
99	FLAGSTAFF ENGINEERING	118					
145	KYE INT'L	180					
146	KYE INT'L	180					
157	LOGITECH	73					
158	LOGITECH	73					
493	SQUARE FIELD CORP.	96SO-2					
494	SQUARE FIELD CORP.	96SO-2					
261	SUMMAGRAPHS	91					
262	SUMMAGRAPHS	91					
279	TRUE DATA	279					
812	SOFTWARE SECURITY						
14	ALADDIN KNOWLEDGE SYS.	306					
174	MICRO SECURITY SYS.	256					
175	MICRO SECURITY SYS.	256					
429	MICROPHAR	96IS-16					
216	PROTECH MARKETING	56					
239	RAINBOW TECH	263					
240	RAINBOW TECH	263					
304	RAINBOW TECH	317					
305	RAINBOW TECH	317					
256	SOFTWARE SECURITY	41					
813	SYSTEMS						
16	ADVANCED LOGIC RESEARCH	2					
17	ADVANCED LOGIC RESEARCH	3					
*	AMPRO	207					
25	AST RESEARCH	15					
26	AST RESEARCH	15					
40	BEST COMPUTER	284					
41	BEST COMPUTER	284					
	BINARY TECH	360					
56	CAMBRIDGE N.A.	131					
*	COMPAQ	70,71					
71	COMPUTRADE	102					
487	COMTEQ COMPUTER CORP.	96SO-4					
488	COMTEQ COMPUTER CORP.	96SO-4					
406	COPAM	96IS-27					
82	DELL COMPUTER	CII,1					
*	DELL COMPUTER	204A-B					
409	ELECTRONIC EQUIPMENT	96IS-44					

READER SERVICE

Inquiry No.	Page No.	Inquiry No.	Page No.	Inquiry No.	Page No.	Inquiry No.	Page No.
446 U.S. MICRO ENGINEERING 96IS-18		105 FOX SOFTWARE	23	114 GENESIS DATA SYSTEMS	86	829 OTHER—LANGUAGES	
447 U.S. MICRO ENGINEERING 96IS-18		106 FTG DATA SYSTEMS	364	115 GENESIS DATA SYSTEMS	86	44 BINARY TECH	360
287 VNS AMERICA	274	112 GENERIC SOFTWARE	101	122 HAMMERLY COMPUTER SERV. 31		268 TECHNOLOGY RESOURCE ..	178
481 WEDGE TECHNOLOGIES 96M/AT-3		113 GENERIC SOFTWARE	101	139 JENSEN & PARTNERS	133	269 TECHNOLOGY RESOURCE ..	178
307 WELLS AMERICAN	105	431 NOVELL	96IS-39	149 LAHEY COMPUTER SYSTEMS 276		299 Z-WORLD	359
308 WELLS AMERICAN	105	218 PROXIMITY	46	248 SAIC	56		
301 ZEOS INTERNATIONAL	88,89	219 PROXIMITY	46	444 VCH-VERLAG	96IS-38		
		* RAIMA	51	302 ZORTECH	156	830 OTHER—CROSS DEVELOPMENT	
						* SOFTWARE DEV. SYS.	99
SOFTWARE		820 IBM/MSDOS APPLICATIONS		826 IBM/MSDOS—UTILITIES		831 MAIL ORDER/RETAIL	
		Scientific/Technical				486 4 GUYS COMPUTERS	96SO-7
814 APPLE2/MAC APPLICATIONS		42 BINARY ENGINEERING	28	12 AGRANAT SYSTEMS	46	541 4 GUYS COMPUTERS	96PC-14
Business/Office		85 DIGITAL RESEARCH	108	28 ATRON	64	11 ADVANTAGE SOFTWARE	211
M11 IMAGINE THAT!	228	118 GOLDEN BOW	42	46 BLAISE COMPUTING INC.	49	22 APPLIED PROGRESSIVE ELEC. 372,373	
M19 PMC TELESYSTEMS INC.	231	119 GOLDEN BOW	42	47 BOLT SYSTEMS	154	29 A.C.P.	371
		122 HAMMERLY COMPUTER SERV. 31		48 BORLAND	69	30 A.N. WHOLESALE & RETAIL ..	360
		* IBM	203	49 BORLAND	69	* BUYERS MART	338-348
815 APPLE2/MAC APPLICATIONS		163 MATHSOFT	67	114 GENESIS DATA SYSTEMS	86	* BYTE BOOK CLUB	192,193
Scientific/Technical		164 MATHSOFT	67	115 GENESIS DATA SYSTEMS	86	* CALIFORNIA DIGITAL	369
M11 IMAGINE THAT!	228	M14 MICROSIM CORP.	218	122 HAMMERLY COMPUTER SERV. 31		303 CLONE COMPUTERS	350,351
M1 MICROGROUP	224	M15 MICROSIM CORP.	218	423 I X I	96IS-40	* COMPACT DISK PRODUCTS ..	54
M2 MICROGROUP	224	322 NATIONAL INSTRUMENTS .. CIII		143 KNOWLEDGE GARDEN	252C	* COMPUCLASSICS	145
M16 NICUS	236	323 NATIONAL INSTRUMENTS .. CIII		425 MASHOV SOFTWARE EXP 96IS-47		63 COMPUSAVE	357
M17 NICUS	236	* ORACLE	85	306 MATRIX SOFTWARE	302	65 COMPUTER BOOK CLUB	113
M22 SPECTRA BLUE	252	207 PATTON & PATTON	130	188 MIX SOFTWARE	329	68 COMPUTER MAIL ORDER 106,107	
		210 PERSONAL TEX	160	208 PERISCOPE	159	69 COMPUTER SYSTEMS RES. 44,45	
816 APPLE2/MAC APPLICATIONS		258 SPECTRUM	35	209 PERISCOPE	159	70 COMPUTERLANE	194
Word Processing		259 STATSOFT	121	211 PHAR LAP SOFTWARE	48	526 CONTINENTAL TRADING 96MW-6,7	
M18 PARAGON CONCEPTS, INC. ...	227			212 POCKETSOFT	174	527 CONTINENTAL TRADING 96MW-6,7	
		821 IBM/MSDOS APPLICATIONS		213 PRECISION PLUS	60	75 CORPORATE COMPUTERS OF IOWA .57	
		Word Processing		234 QUARTERDECK	134,135	76 CORPORATE COMPUTERS OF IOWA .57	
836 APPLE2/MAC-CAD		242 REFERENCE SOFTWARE	169	235 QUARTERDECK	134,135	* DAMARK	152
M30 AUTODESK, INC.	238,239	249 SAMNA	155	236 QUARTERDECK	134,135	507 DIRECT OF NEW ENGLAND 96NE-6	
* CLARIS SOFTWARE	232,233			237 QUARTERDECK	134,135	87 DISKOTECH	360
M8 DOUGLAS ELECTRONICS	248	822 IBM/MSDOS—CAD		438 Q.T. SOFTWARE	96IS-36	88 DISKETTE CONNECTION	359
M23 VAMP, INC.	234	19 AMERICAN SMALL BUS COMP.142		440 SOFTWARE CONSTRUCTION 96IS-49		89 DISKS AND LABELS TO GO ..	364
M24 VERSACAD	229	20 AMS	370	263 SUPERSOFT	84	91 DYNAMIC ELECTRONICS CO. 370	
M25 VERSACAD	229	53 CAD WAREHOUSE	138	* SWIRL SOFT	356	510 ELECTRIFIED DISCOUNTERS 96NE-1	
		434 PAFEC LTD	96IS-25	* VERMONT CREATIVE	12	329 EXECUTIVE PHOTO & SUPPLY 136	
		294 WINTEK CORP.	7	M27 X TREE COMPANY	243	478 EXPERT SYS. INTEGRATORS 96M/AT-2	
837 APPLE2/MAC-COMMUNICATIONS		295 WINTEK CORP.	359	302 ZORTECH	156	489 FINALSOFT CORP.	96SO-3
M10 HAYES MICROCOMPUTER 222,223		296 WINTEK CORP.	359			490 FINALSOFT CORP.	96SO-3
M26 WHITE PHINE SOFTWARE	220			827 IBM/MSDOS COMMUNICATIONS		546 FINALSOFT CORP.	96PC-9
		823 IBM/MSDOS—LAN		* CLEO SOFTWARE	52	547 FINALSOFT CORP.	96PC-9
817 APPLE2/MAC LANGUAGES		508 EDIMAX COMPUTER CO. 96NE-4		405 COMMUNICATION RES. GRP. 96IS-35		412 GREG MATTER	96IS-61
M32 DIGITALK	251	509 EDIMAX COMPUTER CO. 96NE-4		503 COMMUNICATION RES. GRP. 96NE-11		548 HALSKAR SYSTEMS	96PC-7
M31 LANGUAGE SYSTEMS	231	543 EDIMAX COMPUTER CO. 96PC-6		504 COMMUNICATION RES. GRP. 96NE-11		549 HALSKAR SYSTEMS	96PC-7
		544 EDIMAX COMPUTER CO. 96PC-6		476 COMMUNICATION RES. GRP. 96M/AT-1		529 HARD DRIVES INT'L	96MW-1
818 APPLE2/MAC UTILITIES		200 NORTON-LAMBERT	21	477 COMMUNICATION RES. GRP. 96M/AT-1		491 HARD DRIVES INT'L	96SO-1
M7 CONNECTIX	244			90 DIVERSIFIED COMPUTERS ..	364	492 HARD DRIVES INT'L	96SO-1
819 IBM/MSDOS APPLICATIONS		824 IBM/MSDOS—GRAPHICS		245 FASTLYNX/RUPP	335	528 HARD DRIVES INT'L	96MW-1
Business/Office		92 ECOSOFT	58	126 HI-Q INTERNATIONAL INC.	104	133 I C EXPRESS	362
501 AKER CORP.	96NE-8	161 MAP INFO.	61	142 KEA SYSTEMS	363	416 ICC	96IS-43
502 AKER CORP.	96NE-8	168 MEDIA CYBERNETICS	266	551 KORTEK INC.	96PC-3	138 JAMECO	352,353
23 ASHTON-TATE	30	169 MEDIA CYBERNETICS	266	195 NATURAL MICROSYSTEMS ..	216	550 JB TECHNOLOGIES	96PC-11
24 ASHTON-TATE	30	260 STSC	265	435 PERICOM	96IS-17	6 J.D.R.	374-377
52 C W DATA-LABS	364			252 SCIENTIFIC ENDEAVORS CORP. 362		7 J.D.R.	374-377
* CCM/MCGRAW HILL	271	825 IBM/MSDOS—LANGUAGES		266 TALKING TECHNOLOGY	364	* MACMILLAN BOOK CLUBS INC. 25	
64 COMPUTER ASSOCIATES ..	76,77	31 BE AWARE, INC.	104	278 TRAVELING SOFTWARE	153	511 MANCHESTER EQUIPMENT 96NE-10	
		32 BE AWARE, INC.	104			162 MARYMAC INDUSTRIES	364
		49 BORLAND	69	828 OTHER APPLICATIONS		426 MAYFAIR MICROS	96IS-37
				Business/Office		167 MEAD COMPUTER	358
				268 TECHNOLOGY RESOURCE ..	178	168 MEDIA CYBERNETICS	266
				269 TECHNOLOGY RESOURCE ..	178		

We've Invented the Future of Instrumentation Software . . . Twice.

With Words With Pictures Acquisition

Integrated libraries for GPIB, RS-232, A/D-D/A-DIO plug-in cards, and modular instruments.

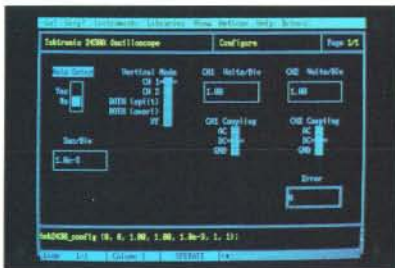

Intuitive character-based function panels that automatically generate source code.

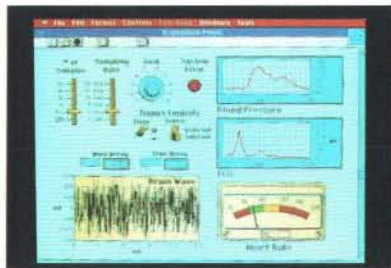

Front panel user interface with virtual instrument block diagram programming.

Analysis

Extensive libraries for data reduction, digital signal processing, and statistical analysis.



Over 100 analysis functions plus all the built-in functions of your language.

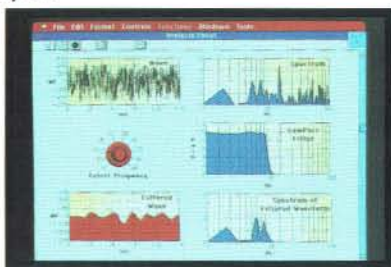

Over 250 icons for computation and analysis.

Presentation

Flexible high-performance graphics and report generation.

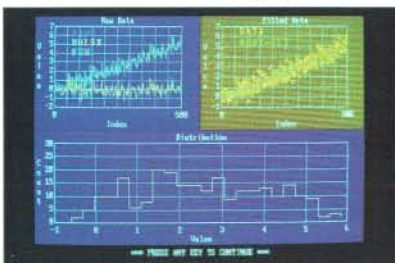

Extensive graphics support for CGA, EGA, MCGA, VGA, and Hercules.

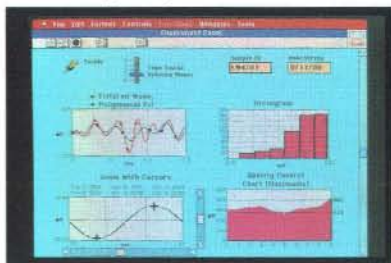

Macintosh Desktop Publishing compatibility.



The Software is the Instrument™
12109 Technology Boulevard
Austin, Texas 78727-6204
800/531-4742 512/250-9119

LabWindows®
for the DOS-based PC and PS/2,
with Microsoft QuickBASIC or C.

LabVIEW®
for the Apple Macintosh.

National Instruments of Japan 81 (03) 788-1921 • National Instruments of France (1) 48 65 33 70 • National Instruments United Kingdom 44-01-549-3444 • ARGENTINA 541/46-5776 /0628
AUSTRALIA 61 (3) 879-2322 • BELGIUM 02/735.21.35 • CANADA 416/890-2010-613/596-9300-(514) 747-7878-403/295-0822-(604) 988-2195 • CHILE 56 2253689 • DENMARK 45 02-251122
FINLAND 358 90-372 144 • FRANCE 33 (1) 69077802 • HONG KONG 852 0-262707-852 0-262945 • IRELAND 353 042 72282 • ISRAEL 972 324298 • ITALY 39-2-98491071-2-3 • KOREA (02) 776-38
MEXICO 52 660 4323 • THE NETHERLANDS 31 070-996360 • NEW ZEALAND 64 09 444-2645 • NORWAY 02-531250 • PORTUGAL 19545313 • SINGAPORE 65 29 11336
SOUTH AFRICA 27 (011) 787-0473 • SPAIN 34 (1) 455 81 12 • SWEDEN 46 08 792 11 00 • SWITZERLAND 41 65 52 8949 • TAIWAN/THE REPUBLIC OF CHINA 886 (02) 7036280 • THAILAND 66 2349330
UNITED KINGDOM 44 273 608 331 • WEST GERMANY 49 89 807081

Circle 322 on Reader Service Card for LabWindows.
323 for LabVIEW

LabWindows

LabVIEW

Tandy® Computers: The broadest line of PCs in America.

The Tandy 3000 NL



Affordable 286
power and
remarkable
expansion.

The Tandy 3000 NL is the right choice for your growing business. From the outset, you'll have an Intel® 80286-based system clocked at 10 MHz. You'll have the performance to manage productivity applications more effectively under MS-DOS®, and the potential for multitasking under MS® OS/2.

Now take on tomorrow: outfit the 3000 NL with a second 3½" drive, and you still have room for two front-panel 5¼" drives—floppy or hard disk, tape or disk

cartridge. Custom configure your system using seven expansion slots. Add an 80287 math coprocessor. Expand the memory to up to 16MB.

And with the 10 MHz bus design, the 3000 NL can transfer data across a network at high speeds. Our 3Com® workgroup lets your people and PCs work together, so your entire office can share information and route messages—electronically. And with IRMALAN™, up to 32 people

in your workgroup can access your company's IBM® mainframe computer. We can provide the workgroup solution to meet your needs.

Radio Shack Computer Centers offer the most comprehensive range of support services in the industry to maximize your investment. The bottom line? We work hard for your business.

The new-generation Tandy 3000 NL. From the best-selling family of PCs made in America.

Tandy Computers: Because there is no better value.™

Intel/Reg. TM Intel Corp. MS-DOS and MS/Reg. TM Microsoft Corp.
3Com/Reg. TM 3Com Corp. IRMALAN/TM Digital Communications
Associates, Inc.

Radio Shack®
COMPUTER CENTERS
A DIVISION OF TANDY CORPORATION